

Working Group Instructions

- **Working group members may speak and show webcam video**
 - Click on "Participants" or "Reactions" then "Raise hand" (A) button
 - "Raise Hand" may be a button (B) or found under "... " (More Options) (C)
- **Members of the public are muted and cannot show webcam video**
- **Public can write questions or to ask for assistance in Q&A window**
 - Questions may be submitted at any time and project staff will address them, as time allows, after working group member discussion
- **Technical support – Andy Reker – areker@cambridgema.gov**

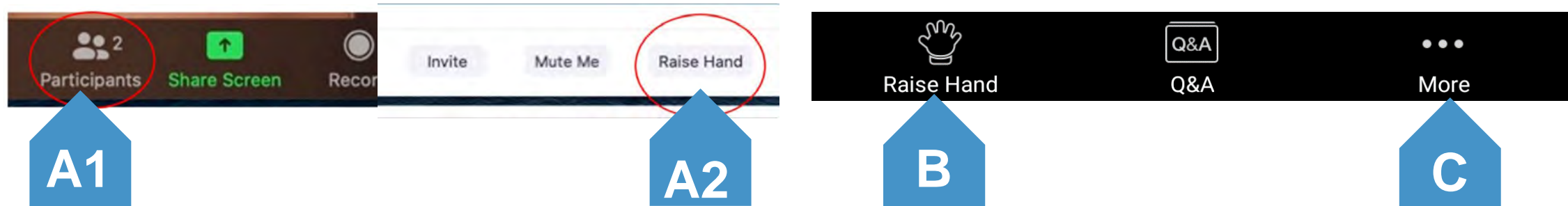



**River Street
Reconstruction**

Remote Participation Instructions

- **Working group members may speak and show webcam video**
 - Working Group Members: use "raise hand" to facilitate discussion
- **Members of the public are muted and cannot show webcam video**
- **Public can write questions or to ask for assistance in Q&A window**
 - Questions may be submitted at any time, as time allows, project team will address questions in Q&A during public comment
- **Technical support – Andy Reker – areker@cambridgema.gov**

Bottom Panel
of Zoom
Screen





Working Group # 12

Wednesday, November 17, 2021

Welcome and Overview

Objectives for Today's Meeting

- 1. Share Project Update**
- 2. Present Carl Barron Plaza Final Design**
- 3. Working Group Wrap-up**

Today's Agenda

- **Welcome and Overview** 5 minutes
- **Project Status** 5 minutes
- **Engagement & Design Review** 7 minutes
- **Carl Barron Plaza Final Design** 35 minutes
- **Working Group Discussion** 15 minutes
- **Public Comment** 10 minutes
- **Wrap-up and Next Steps** 5 minutes

Community & Stakeholder Engagement

Who We Talked To

- 17 In-person interviews
- Walking tours
- Two in-person Carl Barron Plaza engagement events
- 4 Public meetings
- 12 Working Group meetings
- Stakeholder Design meetings
 - City's Urban Design & Human Services teams
 - Central Sq. Business Improvement District (BID)
 - Holmes Building management & resident representatives
 - Baptist Church leaders
 - Central Square Advisory Committee

Design Process

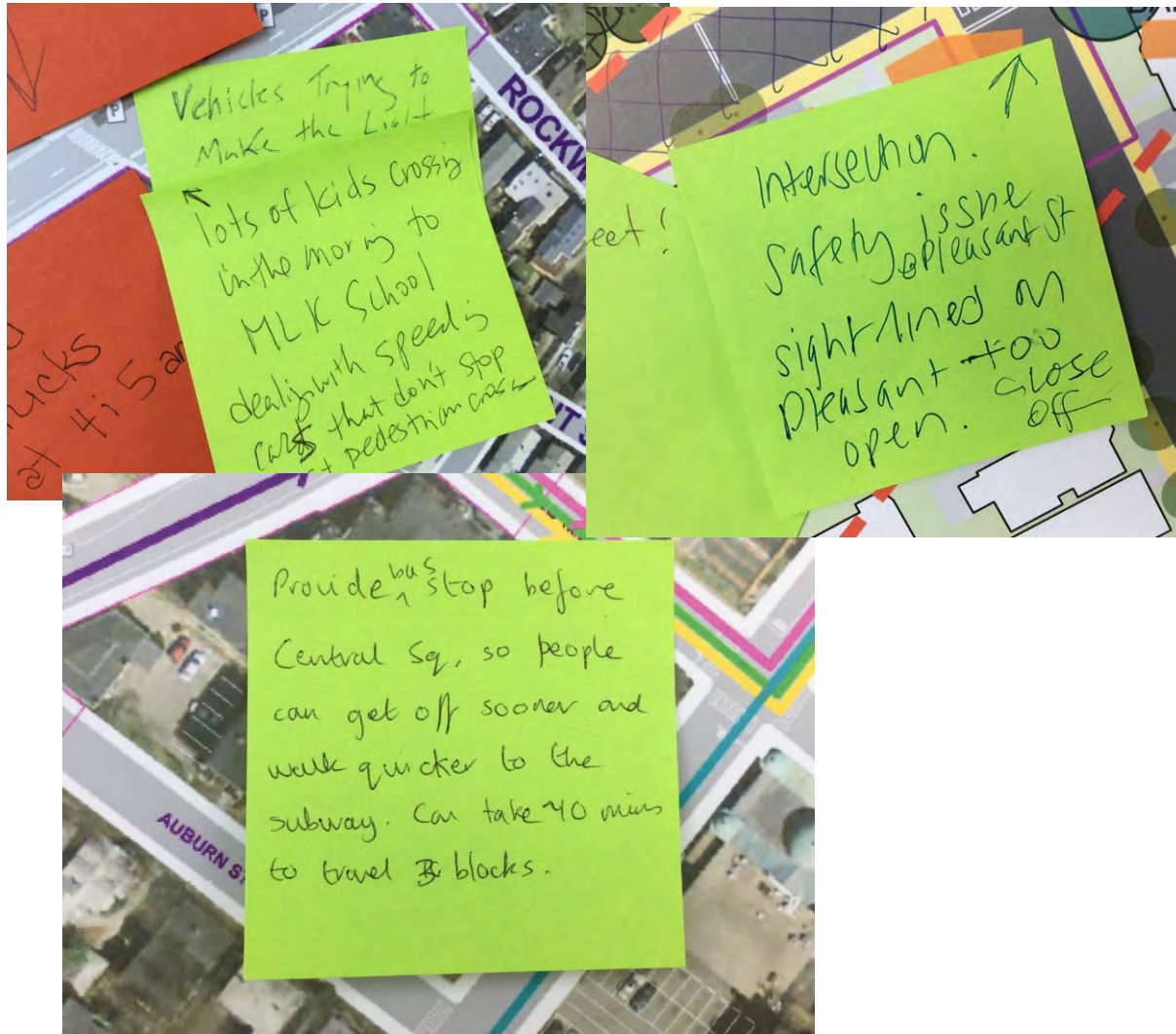

Public Meeting #4 Takeaways

- Meeting on June 22 from 5:30-7:30
- Type of Comments
 - Ensuring the plaza serves the unhoused community, and others in a safe and beautiful space
 - Bus shelter design should keep rider comfort and convenience in mind
 - Plaza should capture spirit of art and culture of Central Square
 - Keep separate space for moving through plaza and resting/events

Presentation Video

Welcome to the River Street Reconstruction Virtual Open House. The City and project team created this site to show you the proposed design plans for Carl Barron Plaza as a part of the River Street Reconstruction Project ([click here to go to the River Street Reconstruction project page](#)). Scroll down to learn more about how the designs for Carl Barron Plaza have progressed since our October 2020 virtual open house. At any point, you can skip ahead using the **navigation bar** up top.

Watch the video below to learn about the proposed Carl Barron Plaza designs.



Carl Barron Plaza Final Design

Shared Design Goals Review

Inclusive	Attract a wide range of users while preserving usability for the existing regulars
Activated	Create a vibrant space through everyday activities and special programming
Safe	Create a feeling of safety for everyone
Flexible	Allow for a wide range of uses and activities that can evolve over time
Attractive	Improve the perception of the space
Comfortable	Provide seating, lighting and amenities that promote short- and long-term lingering
Multimodal	Ensure pedestrian and bicyclist flow, and coordinate with transit users' needs
Functional	Provide materials and amenities that are functional and easily maintained
All-Season	Provide comfortable year-round use and reduce microclimate influence

Site Analysis & Constraints

- **Underground Utilities/Subway**
 - Major public and private utilities
 - Shallow utilities (electric, comms)
 - Sewer lines
 - Red Line Subway - Mass Ave.
 - Sanitary and drainage Lines
- **Eight (8) Existing Trees**
- **Solar Orientation**
 - Green St. edge: Sunny
 - Mass Ave: Shady



Urban Design Guidance

Developed Through Meetings with City's Urban Design Team, BID, Holmes Building, Church:

- Establish Carl Barron as a focal point
- Be bold, creative, playful and whimsical
- Provide enough height to be visible from a distance, but also a pedestrian scale
- Use repetition to strengthen the visual unity of the plaza
- Build in capacity for placemaking, functionality and programming where possible
- Apply lighting effects
- Reflects Central Square as a center of arts and culture



Previous Design Options



Option A: Sculptural Ribbon



Option B: Complementary Structures



Option A: Sculptural Ribbon



Option B: Complementary Structures

Working Group and Community Feedback Summary

- General preference for the ribbon option
- Accommodating and safe space for everyone
- Ability to maintain ribbon structure
- Maximize tree planting
- Lighting incorporation into ribbon
- Address accessibility concerns
- Balanced Seating between fixed and moveable
- Weather considerations
- Wayfinding / Information suggestions
- Embrace local character/identity
- Timeless design

Feedback Implementation

Safe Space

Maintenance

Trees

Lighting

Accessibility

Weather

Wayfinding

Local Identity

Timeless

- Dynamic space to draw visitors on a daily basis
- Activate the space with programmed events

Feedback Implementation

Safe Space

Maintenance

Trees

Lighting

Accessibility

Weather

Wayfinding

Local Identity

Timeless

- Ribbon - add graffiti coating for easy cleaning
- Add art/design to hide imperfections
- Other surfaces are high quality and durable

Feedback Implementation

Safe Space

Maintenance

Trees

Lighting

Accessibility

Weather

Wayfinding

Local Identity

Timeless

- Maximize tree planting to offer shaded gathering opportunities
- Proposed 24 new trees when previously there were 8 trees

Feedback Implementation

Safe Space

Maintenance

Trees

Lighting

Accessibility

Weather

Wayfinding

Local Identity

Timeless

- Bright, vibrant atmosphere to maintain activation into the evening hours
- Lighting in the ribbon brings whimsy and energy to the space

Feedback Implementation

Safe Space

Maintenance

Trees

Lighting

Accessibility

Weather

Wayfinding

Local Identity

Timeless

- Accessible plaza with equal opportunity
- Benches have some arm rests and bench backs
- Balance of fixed and flexible seating options

Feedback Implementation

Safe Space

Maintenance

Trees

Lighting

Accessibility

Weather

Wayfinding

Local Identity

Timeless

- Wind/rain/shade protection by bus shelters and trees

Feedback Implementation

Safe Space

Maintenance

Trees

Lighting

Accessibility

Weather

Wayfinding

Local Identity

Timeless

- Real time bus information on shelters, signs in plaza
- Location held and equipped for community kiosk

Feedback Implementation

Safe Space

Maintenance

Trees

Lighting

Accessibility

Weather

Wayfinding

Local Identity

Timeless

- Bold, dynamic design representative of the local culture
- Art on the ribbon can also reflect local character or current events

Feedback Implementation

Safe Space

Maintenance

Trees

Lighting

Accessibility

Weather

Wayfinding

Local Identity

Timeless

- Allow the ribbon art to be re-envisioned periodically to evolve over time

Ribbon Direction Based on Feedback

- **RIBBON DIRECTION BASED ON FEEDBACK:**
- The ribbon itself is a bold artistic statement that ties the overall site together from one end to the other
- Introducing graphic or painterly art to the surface of the ribbon can reflect local character
- Adding pattern/color/art will deter vandalism
- Artists respect other artists' work
- Allow the art to be re-envisioned periodically as community evolves.

Artist Selection Process - Ribbon

- **ARTIST SELECTION PROCESS - RIBBON**
- Cambridge Arts Council will develop an artist selection process in collaboration with the BID, community members, and city staff. Arts Council invites anyone interested to participate in the process
- Outreach: Call-to Artists , promotion, and Cambridge Arts artist registry
- Small Jury of art professionals will select 3-4 finalists
- Finalists will be compensated to develop proposals
- Committee of stakeholders representing diverse perspectives will select a design for the ribbon

Carl Barron Plaza – SPORTS Design Collaboration

SPORTS is the award-winning art and design studio of Molly Huncker and Greg Corso, based in Syracuse, NY

They develop compelling public art structures and public spaces that:

- Leverage the possibility for simple, powerful design gestures to have significant urban impacts
- Support communities and catalyze social activities

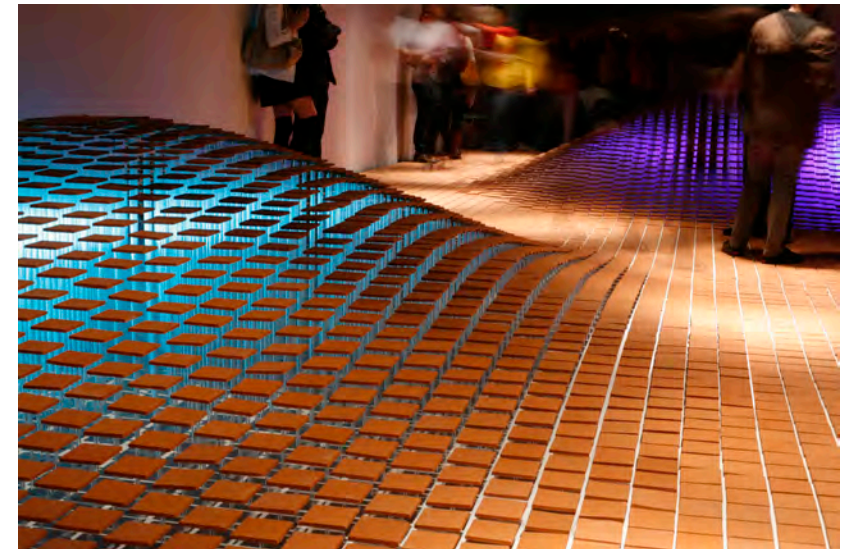
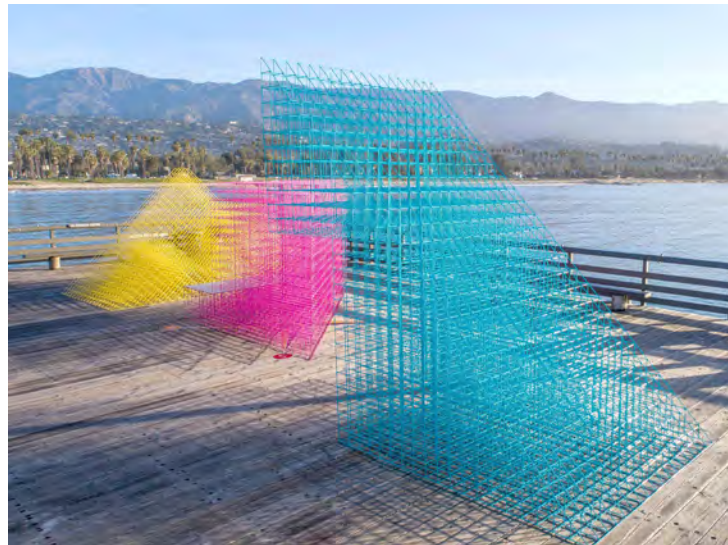

Carl Barron Plaza – SPORTS Design Assessment

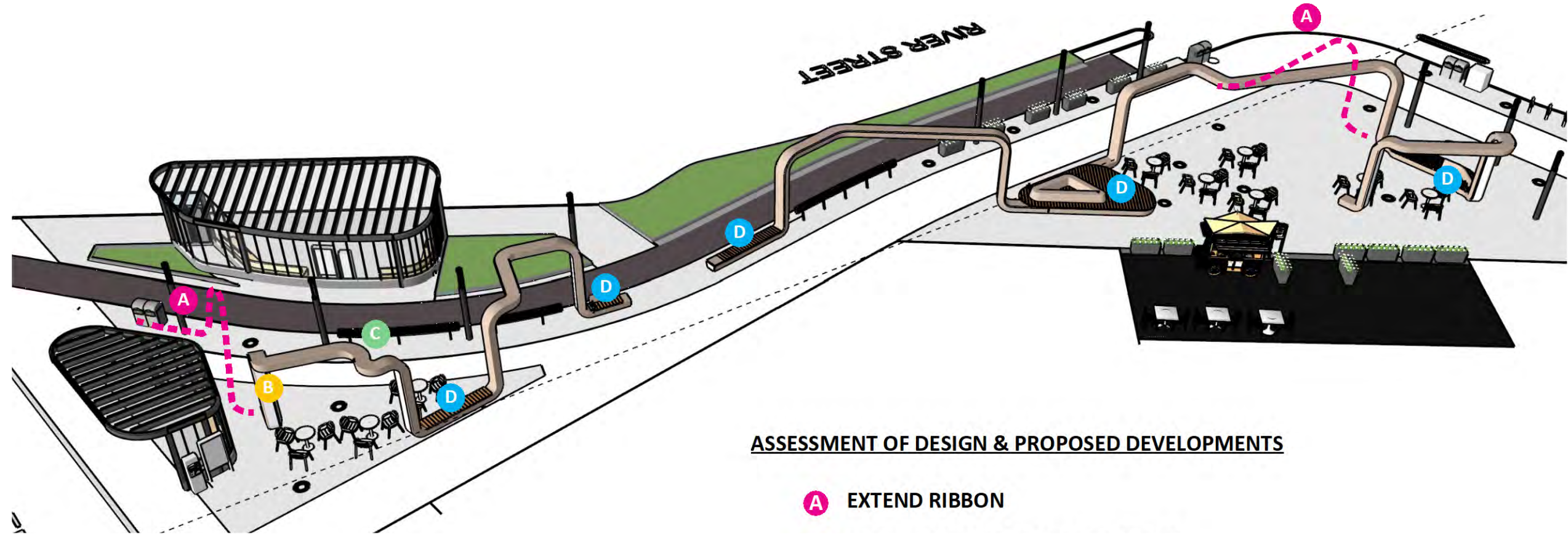

ASSESSMENT OF DESIGN & PROPOSED DEVELOPMENTS

- A** EXTEND RIBBON
- B** MAKE CURVE RADIUS CONSISTENT
- C** SIMPLIFY GEOMETRY IN SMALL AREAS
- D** SYSTEMATIZE SEATING DESIGN

Carl Barron Plaza – Overview

LEGEND

- | | | |
|-----------------------------------------------------------|---------------------------------|------------------------------------------|
| 1. Pedestrian scale lighting | 5. Architectural ribbon element | 9. "Flexible" plaza space |
| 2. Drinking water bottle fill stations | 6. Separated bicycle lane | 10. Space for possible information kiosk |
| 3. Bus shelters w/ real-time information digital displays | 7. Trees and planting areas | 11. Sharps container |
| 4. Seating - fixed and flexible | 8. Concrete sidewalk | 12. Bike Racks |

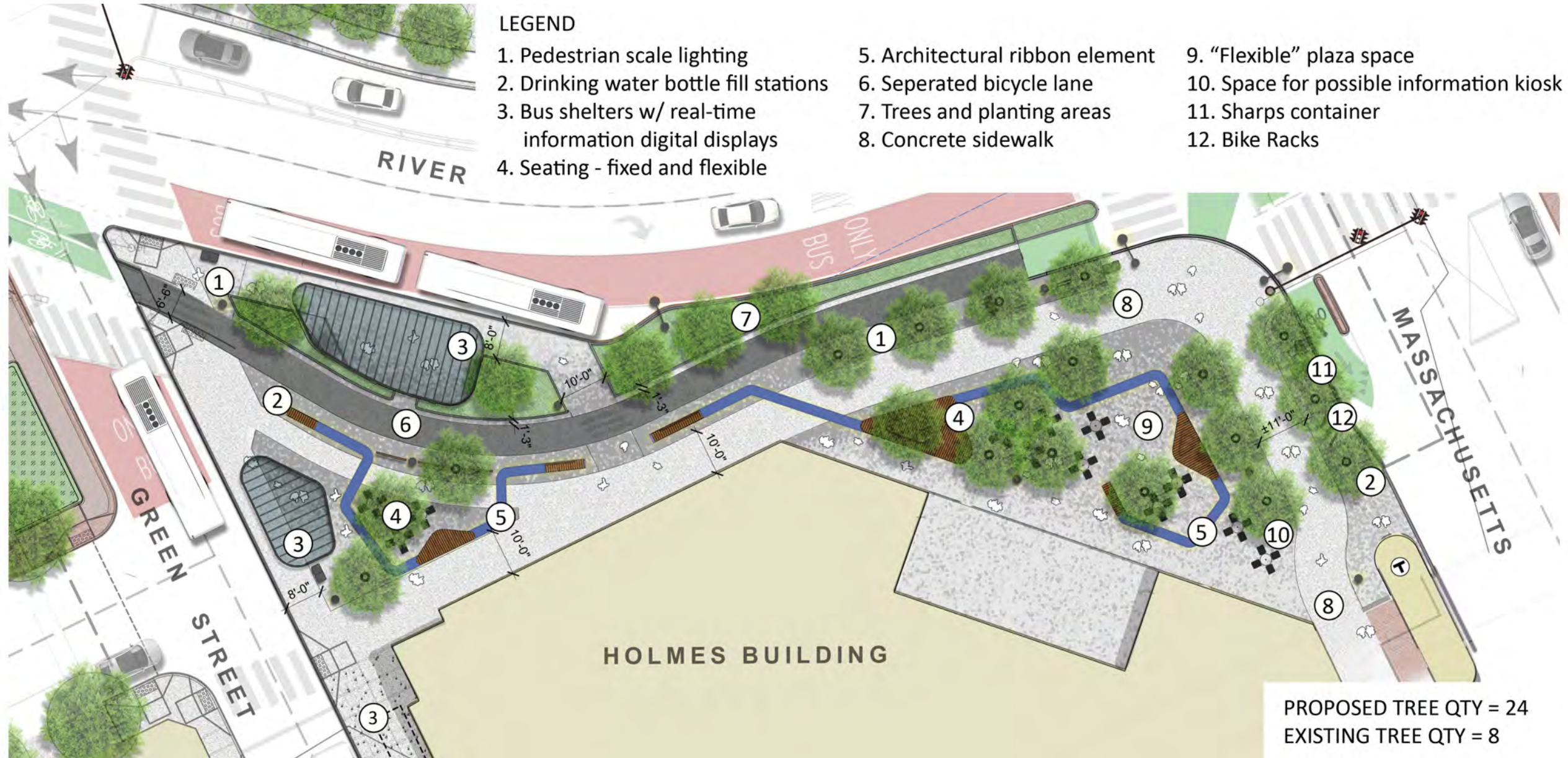

PROPOSED TREE QTY = 24
EXISTING TREE QTY = 8

Carl Barron Plaza – Proposed Condition

The ribbon color in perspective renderings is a placeholder and will not be the final design

A bold, sculptural feature serves as a ribbon of continuity throughout the space.

Maximize tree planting, providing shaded gathering areas



Carl Barron Plaza – Proposed Condition

The ribbon color in perspective renderings is a placeholder and will not be the final design

A bold, sculptural ribbon draws visitors into the plaza.

Simple bus shelters frame the gateway.



Carl Barron Plaza – Proposed Condition

The ribbon color in perspective renderings is a placeholder and will not be the final design

The Green street plaza offers additional outdoor gathering opportunities.



Carl Barron Plaza – Proposed Condition

The ribbon color in perspective renderings is a placeholder and will not be the final design



A combination of flexible and fixed seating offer numerous gathering opportunities and can accommodate larger programmed events.

Platform seating has been introduced for placemaking/performance opportunities.



Carl Barron Plaza – Proposed Condition

The ribbon color in perspective renderings is a placeholder and will not be the final design

Color has been added to flexible furnishings to more align with the vibrant artistic community



Carl Barron Plaza – Proposed Condition

The ribbon color in perspective renderings is a placeholder and will not be the final design



Perforated metal with backlighting has been introduced to accentuate the ribbon structure. Underlighting touch down points provides the illusion the sculpture is floating.

Carl Barron Plaza – Proposed Condition

The ribbon color in perspective renderings is a placeholder and will not be the final design

Perforated metal with backlighting has been introduced to accentuate the ribbon structure. Underlighting touch down points provides the illusion the sculpture is floating.



Carl Barron Plaza – Proposed Condition

The ribbon color in perspective renderings is a placeholder and will not be the final design

The ribbon alignment was adjusted to create a powerful gateway facing Massachusetts Ave sidewalk, while increasing seating opportunities.



Ribbon Design - Structural Core

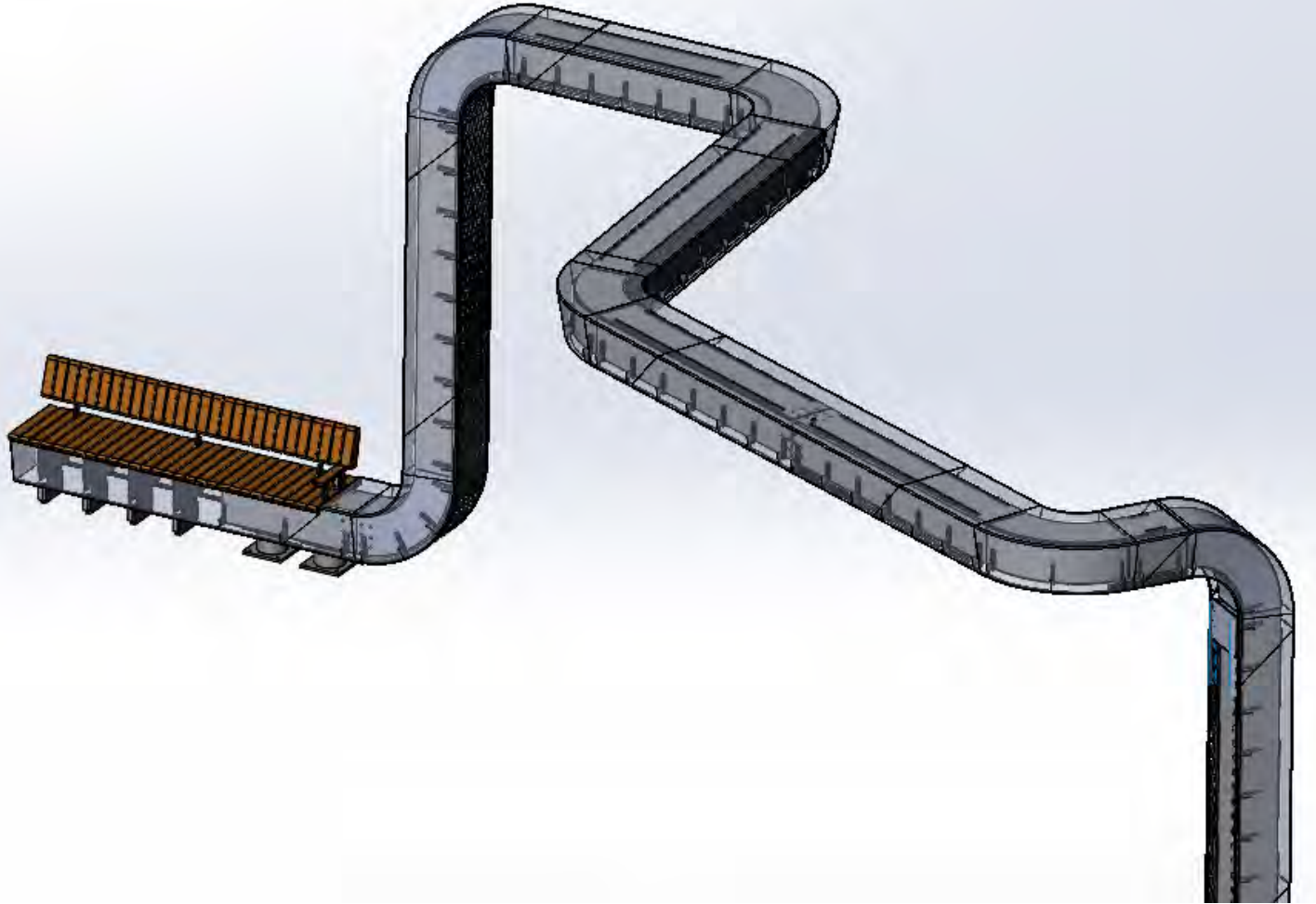

Ribbon with Seating
Isometric View

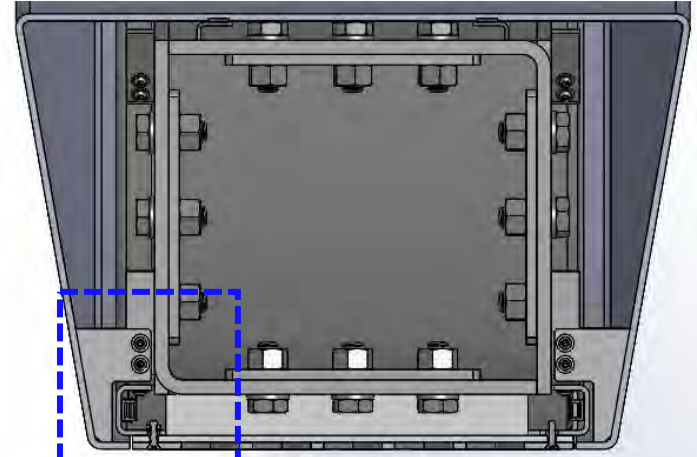

Structural Core with Outer Skin
Section

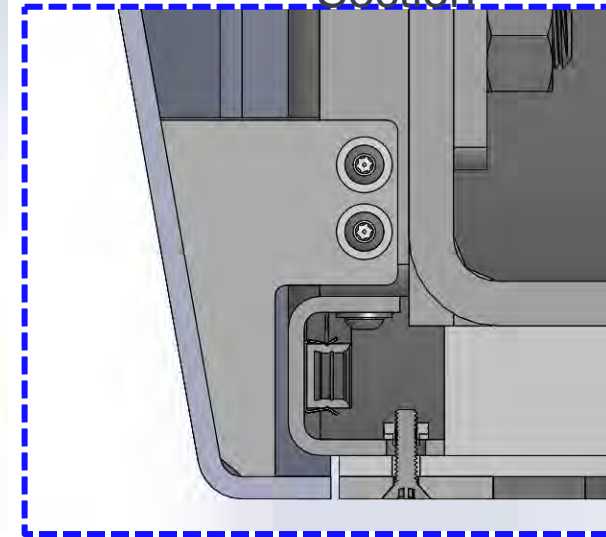

Structural Core
with Outer Skin
Detail

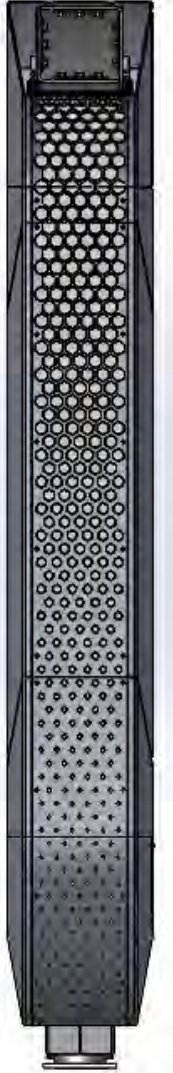

Lighting Panel
Perforated Pattern
Elevation

Ribbon Design – Seating Detail

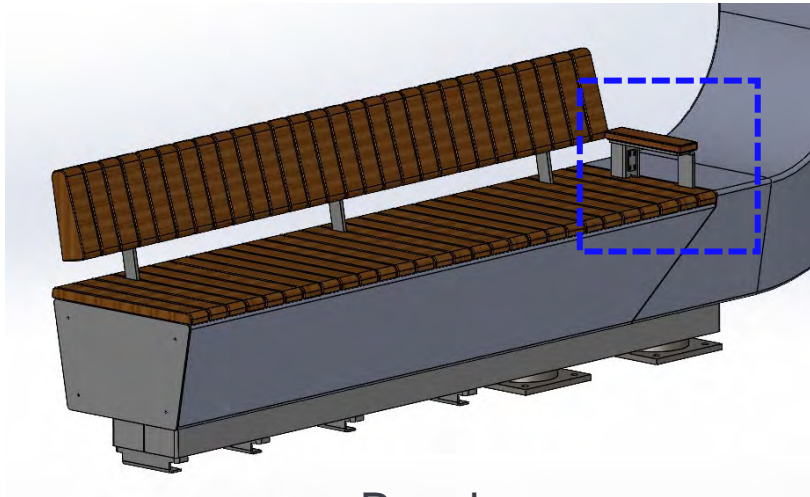

Bench
Isometric View

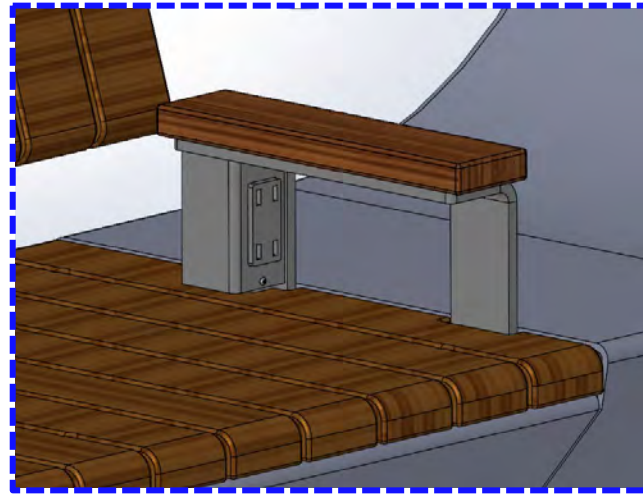

Arm Rest

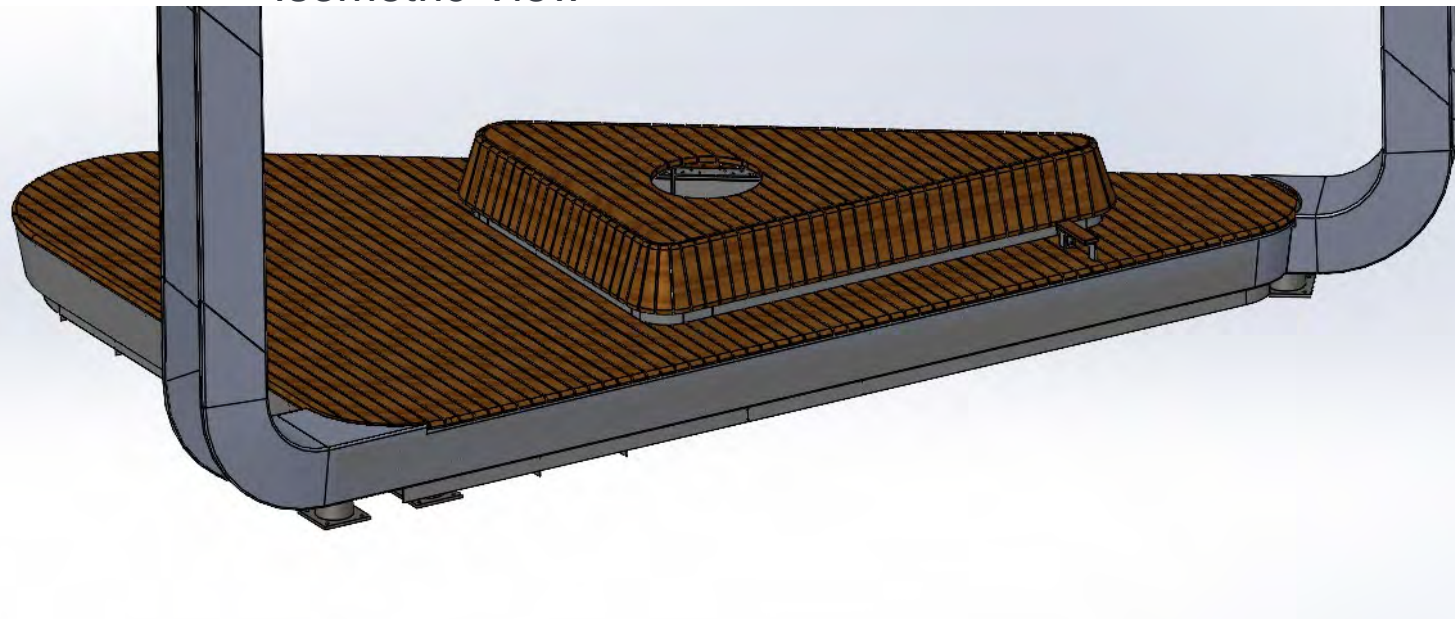

ISOMETRIC VIEW

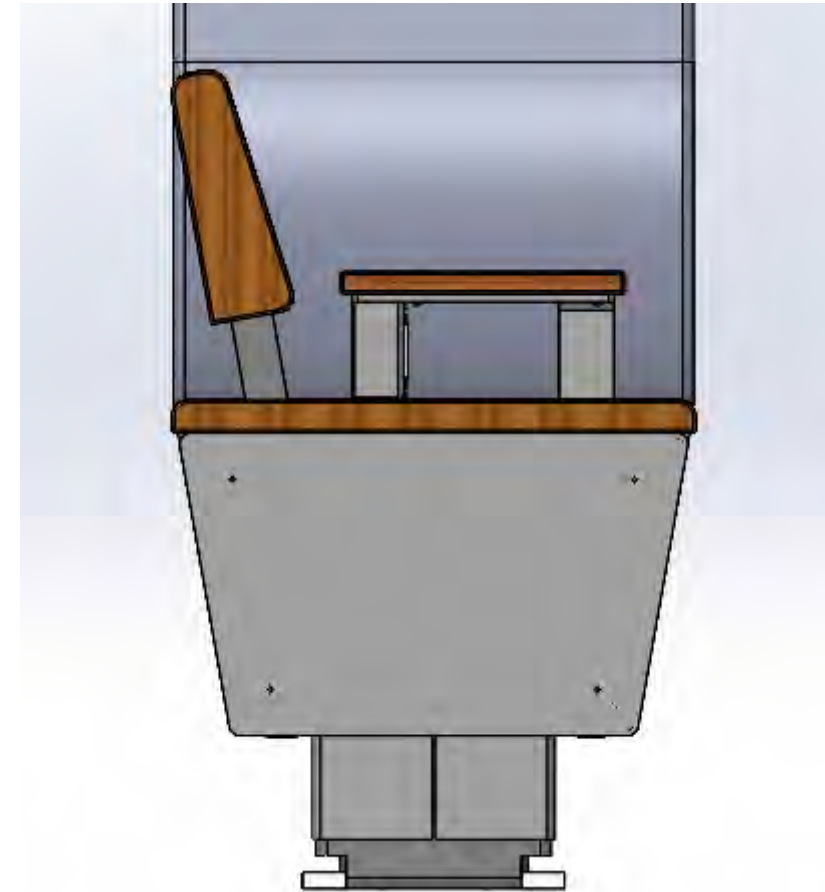

Bench
Section

USB and Electrical outlets are under consideration for final design.

Carl Barron Plaza – Number of Seats

	Current Plaza	Current Green Street Plaza area	Total Current	Proposed Plaza	Proposed Green Street Plaza area	Total Proposed
Fixed seats (brick, steel, stone, wood benches)	65	6	71	38	23	61
Movable , flexible seats	0	0	0	28	16	44
Bus stop seating (benches in shelters)	N/A	8-12	8-12	N/A	14 or more	14+
Total	65	14-18	79-83	66	53	119+

Carl Barron Plaza – Safe, Cabled Seating



SECURITY CABLES



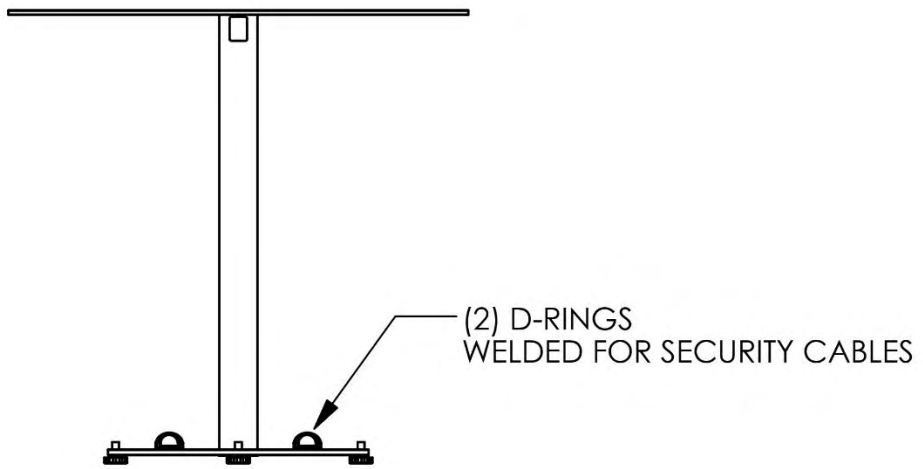
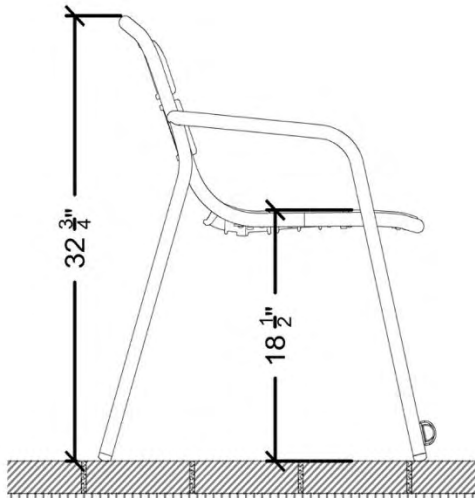

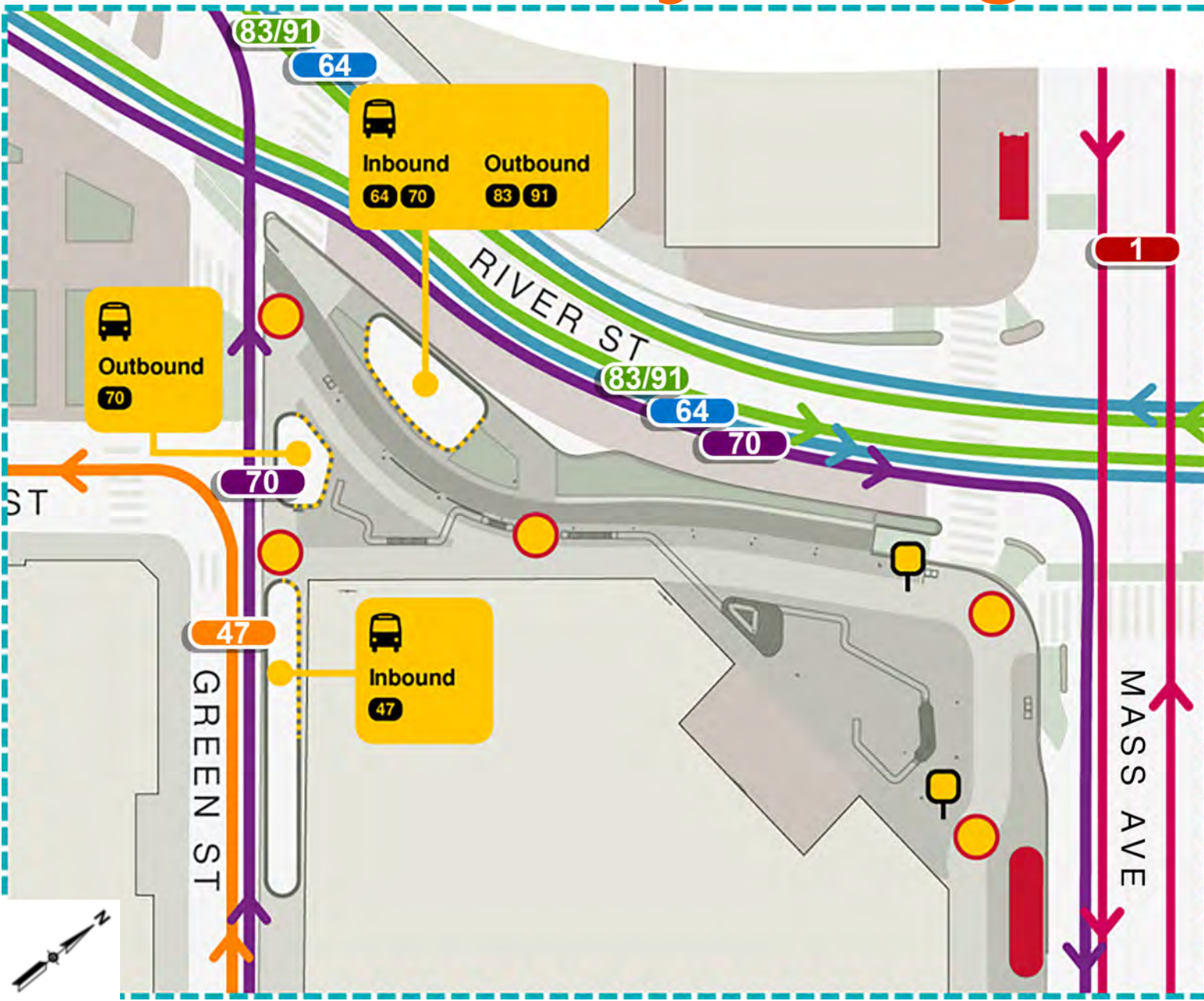

21 CHAIR AND PARK CENTRE TABLE- LANDSCAPE FORMS





Transit Wayfinding



LEGEND

-  Decision Making Point
-  Red Line Headhouse
-  Red Line Stairs/Elevator
-  Proposed Headhouse
-  Transit Wayfinding Sign (Shelter)
-  Transit Wayfinding Sign (Pole)

Bus Routes

-  Route 1
-  Route 47
-  Route 64
-  Route 70
-  Route 83/91

Sample wayfinding sign:

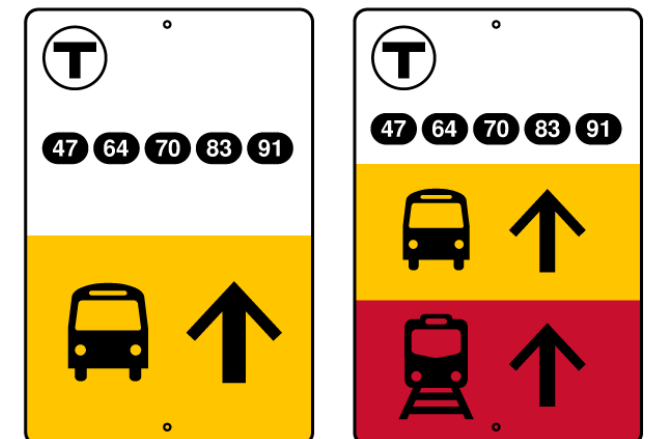

Transit Shelter Design



Transit Shelters serve bus routes 47, 64, 70 (inbound) & 70, 83, 91 (outbound)

River Street Shelter / Operator Booth



Transit Shelter serves bus routes 64, 70 (inbound) & 83, 91 (outbound)

Magazine Street Shelter



Transit Shelter serves bus route 70 (outbound)

Working Group Discussion

Public Comment

Next Steps

Thank You, Working Group!



Cambridgema.gov/RiverStreet

CDD > Projects > River Street Reconstruction

River Street Reconstruction

The scope of the River Street Reconstruction project includes River Street, the bus terminal area at River and Magazine Streets, and Carl Barron Plaza (the public plaza space in front of the Amazon, Cambridge Savings Bank, and Holmes building entrance). The primary objectives of the project are to create a street design on River Street that meets the needs of everybody, address the utility and surface infrastructure needs of River Street, and develop and implement a new design for Carl Barron Plaza.

Project goals

- **Provide, to the extent necessary, new sanitary sewer, stormwater and water infrastructure** to ensure adequate utility levels of service. Portions of these systems are more than 100 years old and have fallen into a deteriorated condition over time.
- **Provide new surface infrastructure that meets the needs of all the various users** and does so in a way that engages the local community, contributes to overall enhancement of the neighborhood, and meets the City's goals related to infrastructure, transportation, and urban design. The project aims to create a streetscape design that enables people to travel safely and comfortably by various transportation modes while enhancing the neighborhood context and supporting local businesses.
- **Reconstruct Carl Barron Plaza, the significant open space at the heart of Central Square.** The Plaza design will include consideration of public art, fixed and movable seating, circulation, accessibility, plantings, and landscaping. The project team is also making sure that public plaza design meets the transportation and mobility needs of bus riders and people passing through the plaza.
- **Undertake a robust public process that engages all the various stakeholders** along the corridor including neighbors, neighborhood groups, businesses and business groups, city standing committees, and other advisory committees.

The project team is doing community outreach and design through 2021. Construction is anticipated to begin in late 2021.

The City has budgeted approximately \$25 million for construction of the River Street project.

Stay up to date

[Click here to sign up for email updates on this project.](#)

Tell us your thoughts

[Click here to send the project team a general comment.](#)

Quick Links

I'd like to learn more about...

Select a Topic

Neighborhood or Square

Select One

Current Projects...

Select One



[Click the Map to Explore Cambridge](#)

A 5-STAR Community and National Leader in Sustainability



THANK YOU!

riverstreet@cambridgema.gov