



Appendix G

Traffic Impact and Parking Study



CITY OF CAMBRIDGE

TRAFFIC, PARKING, + TRANSPORTATION

Joseph E. Barr, Director
344 Broadway, Suite 102
Cambridge, MA 02139

August 4, 2020

John Twohig
Cambridgeside Galleria Associates Trust
c/o New England Development
75 Park Plaza
Boston, MA 02109

Scott Thornton, P. E.
Vanasse & Associates, Inc.
35 New England Development Center Drive, Suite 140
Andover, MA 0810-1066

RE: Cambridgeside 2.0 Transportation Impact Study (TIS) Scope

Dear John and Scott:

The Cambridge Traffic, Parking, and Transportation Department (TP+T) received the Transportation Impact Study (TIS) on June 3, 2020 for the proposed CambridgeSide 2.0 Redevelopment project by New England Development on behalf of CambridgeSide Galleria Associates Trust, Cambridge Partners LLC, and NW Cambridge Property Owner LLC. Based on staff review, some corrections and clarifications were needed for us to certify the TIS as accurate and complete and we sent you a letter dated June 24, 2020 with the corrections and clarifications we needed.

We received your updated TIS on July 22, 2020 and based on staff review your TIS is certified as accurate and complete.

Going forward, we look forward to continuing to work with you on this project. Ideally the following items should be completed prior to you submitting your Special Permit Application and certainly in advance of your hearing date. We believe that completing these steps prior to the Planning Board hearing would help make the Planning Board process more efficient and successful.

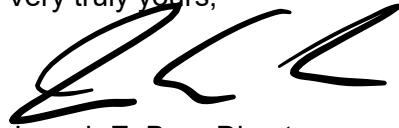
- The Cambridgeside Commercial Parking Facility Permit should be amended so the conditions in the Commercial Parking Facility Permit are aligned with the conditions in the Special Permit, including number of parking spaces with and without potential managed parking, associated Transportation Demand Management (TDM) measures, and any potential parking control or shared parking parameters.
- Because the CambridgeSide 2.0 parking facilities have zoning maximums, particularly for the Office and R&D uses, it will be very important for the Project to

have robust TDM measures so that the parking demands for those uses do not exceed the parking supply. This is generally accomplished by making sure that the employee mode shares align with the number of parking spaces. Therefore, if parking demands are higher than supply, additional TDM measures may be necessary to reduce the parking demands. Although the TIS estimated there will be sufficient parking spaces to accommodate the Project's demand, it had various assumptions, such as employee densities and mode shares in the calculations, so if those assumptions don't play out as expected the parking demands could vary from the analysis. It is in both our interests to have the parking supply and demand be in balance for both the project's success and limit any potential parking spillover.

- The TIS proposed various transportation mitigation measures for the project. As a starting point, it would be helpful if you could provide TP+T a working draft of your proposed mitigation measures and triggers. It will also be important to pair this with the most current information on your project's final parameters so that we are working off the same numbers (i.e., full-build out square feet by land uses, project phasing plan, mitigation triggers, and number of parking spaces with and without potential managed operations).

Thank you again for working with us and please contact Adam Shulman of my staff to discuss in more detail and set up a meeting on these next steps.

Very truly yours,

A handwritten signature in black ink, appearing to read 'J. Barr', written over a horizontal line.

Joseph E. Barr, Director

cc: Adam Shulman, TP+T
Patrick Baxter, TP+T

Transportation Impact Study

CambridgeSide 2.0 Redevelopment
Cambridge, Massachusetts

Prepared for:

New England Development, On Behalf Of:

Cambridgeside Galleria Associates Trust,
Cambridgeside Partners LLC, And
NW Cambridge Property Owner LLC

Cambridge, Massachusetts

July 2020

Prepared by:

 **Vanasse &
Associates inc**
Transportation Engineers & Planners

35 New England Business Center Drive
Suite 140
Andover, MA 01810

CONTENTS

EXECUTIVE SUMMARY	1
Introduction	1
Project Description	1
Consistency With Planning Studies.....	1
Existing Conditions	2
Project-Generated Traffic.....	2
Article 19 Project Review Special Permit Criteria Analysis.....	3
Pud-8 Special Permit Analysis.....	3
Traffic Operations Analysis	3
Parking Analysis.....	4
Project Mitigation.....	5
Intersection Upgrades.....	5
Mitigation Staging.....	5
Additional Mitigation Measures.....	6
Transportation Demand Management Measures.....	6
Conclusion.....	8
INTRODUCTION.....	9
1.0 EXISTING CONDITIONS	11
1.1 Existing Traffic Conditions	11
1.2 Description Of Project Study Area.....	11
1.3 Parking And Loading Facilities.....	12
1.4 Transit Services	12
1.5 Land Use	12
2.0 DATA COLLECTION.....	13
2.1 Automatic Traffic Recorder Counts	13
2.2 Pedestrians.....	15
2.3 Bicycles	17
2.4 Intersection Turning Movement Counts.....	19
2.5 Existing Vehicle Queues	19
2.6 Motor Vehicle Crash Data.....	23

CONTENTS (Continued)

2.7 Existing Public Transit System	32
2.8 Existing Parking Utilization	35
2.9 Bicycle Parking	37
2.10 Existing Parking Operations And Current Rate Schedule.....	38
2.11 Existing Loading And Trash Operations.....	38
2.12 East Cambridge Developments	39
3.0 PROJECT TRAFFIC.....	40
3.1 Trip Generation	40
3.2 Trip Distribution.....	47
3.3 2020 Modified Baseline Condition With Third-Floor Re-Tenanti Use.....	48
3.4 Vehicle Trip Re-Distribution.....	49
3.5 Project Service And Loading.....	51
4.0 BACKGROUND TRAFFIC	52
4.1 First Street Extension And Lechmere Station Relocation	52
4.2 Roadway Improvement Projects.....	53
5.0 TRAFFIC ANALYSIS.....	54
5.1 Site Assignment.....	54
6.0 CAPACITY ANALYSIS	55
6.1 Vehicle Level-Of-Service Analysis.....	55
6.2 Traffic Signal Warrant Analysis.....	71
7.0 QUEUE ANALYSIS.....	73
8.0 RESIDENTIAL STREET VOLUME Analysis	80

CONTENTS (Continued)

9.0 PARKING ANALYSIS.....	81
9.1 Introduction	81
9.2 Existing Parking Conditions.....	81
9.3 Future Parking Conditions.....	84
9.4 Shared Parking Analysis	87
9.5 Bicycle Parking	88
9.6 Commercial Parking Facility Permit Modifications.....	89
9.7 Parking Operations	92
10.0 TRANSIT ANALYSIS	94
10.1 Project Transit Distribution	94
10.2 Summary Of Analysis Results.....	97
10.3 Future Public Transit Conditions.....	98
10.4 Orange Line Project Impacts	99
10.5 Future Private Transit Conditions	99
11.0 PEDESTRIAN Analysis.....	101
12.0 BICYCLE ANALYSIS	108
12.1 Vehicle Turning Volume Conflicts	108
13.0 ARTICLE 19 SPECIAL PERMIT CRITERIA ANALYSIS	113
14.0 PROJECT MITIGATION	127
14.1 Project Mitigation.....	127
14.2 Intersection Upgrades.....	127
14.3 Additional Mitigation Measures.....	130
14.4 Transportation Demand Management Measures	131
14.5 Mitigation Staging.....	132
15.0 CONCLUSION	136
TECHNICAL APPENDIX	

TABLES

Number	Title
1.a.1	Project Building Area Characteristics
1.a.2	Project Parking Characteristics
2.a.1	2020 Baseline Traffic Volumes
2.a.2	Average Hourly Traffic Volumes at ATR Locations
2.b.1	Average Hourly Pedestrian Volumes – Cambridgeside Place
2.b.2	Average Hourly Pedestrian Volumes – First Street
2.b.3	Average Hourly Pedestrian Volumes – Land Boulevard
2.b.4	Average Hourly Bicycle Volumes – Cambridgeside Place
2.b.5	Average Hourly Bicycle Volumes – First Street
2.b.6	Average Hourly Bicycle Volumes – Land Boulevard
2.c.1	Existing Queue Observations
2.c.2	Longfellow Bridge Count Comparison
2.d.1	Vehicle Crash Data Summary
2.d.2	Crash Data Summary – Vehicle to Pedestrian
2.d.3	Crash Data Summary – Vehicle to Bicyclist
2.e.1	MBTA Green Line Service Summary
2.e.2	MBTA Red Line Service Summary
2.e.3	MBTA Bus Service Summary
2.e.4	CambridgeSide Shuttle Bus Ridership History
2.e.5	Average Weekday Shuttle Bus Ridership by Hour
2.f.1	Lower Garage Parking Utilization Summary
2.f.2	Upper Garage Parking Utilization Summary
2.f.3	CambridgeSide Current Parking Rates
3.a.1	East Cambridge Area Mode Splits
3.a.2	Empirical Trip Generation Rates
3.a.3	Project Trip Generation by Mode
3.a.4	Empirical Targeted Retail Trip Generation
3.a.5	CambridgeSide Transient Ticket History

TABLES (Continued)

Number	Title
3.a.6	Monthly Parker Trip Generation
3.a.7	Total Project Net New Vehicle Trip Generation
3.b.1	Trip Distribution Summary
3.c.1	Third Floor Net New Vehicle Trip Generation Summary
3.d.1	Non-Tenant Vehicle Trip Re-Distribution Summary
6.1	Vehicle Level-Of-Service Summary – Signalized Intersections
6.2	Vehicle Level-Of-Service Summary – Unsignalized Intersections
7	Queue Analysis Results
8	Traffic on Residential Streets
9.1	Transient Year over Year Trend
9.2	Long-Term Parking Lease Details
9.3	Existing Parking Utilization
9.4	Proposed Project Parking
9.5	Future Project Parking Utilization
9.6	Bicycle Parking Analysis
9.7	Proposed Commercial Parking Facility Permit Revisions
10.1	Transit System Trip Distribution
10.2	MBTA Green Line Subway Peak Hour Ridership Impacts
10.3	MBTA Red Line Subway Peak Hour Ridership Impacts
10.4	MBTA Bus Route Peak Hour Ridership Impacts
11.1	Pedestrian Level-Of-Service Summary – Signalized Intersections
11.2	Pedestrian Level-Of-Service Summary – Unsignalized Intersections
12	Bicycle-Vehicle Volume Conflicts
13.a	Indicator 1 – Project Vehicle Trip Generation
13.b	Indicator 2 – Project Vehicle LOS
13.c	Indicator 3 – Traffic on Residential Streets
13.d	Indicator 4 – Lane Queue
13.e.1	Indicator 5a – Pedestrian LOS

TABLES (Continued)

<u>Number</u>	<u>Title</u>
13.e.2	Indicator 5b and 5c – Pedestrian and Bicycle Facilities
14.1	Mitigated Vehicle Level-Of-Service Summary – Signalized Intersections
14.2	Mitigated Queue Analyses Results
14.3	Potential Mitigation Staging

FIGURES

Number	Title
1.a.1	Ground Floor Plan with Vehicle Access
1.a.2	Ground Floor Plan with Pedestrian and Bicycle Access
1.a.3	Existing Conditions Survey
1.b.1	Intersection Inventories - O'Brien Highway at Land Boulevard and Museum Way
1.b.2	Intersection Inventories - O'Brien Highway at Cambridge Street and East Street
1.b.3	Intersection Inventories – Cambridge Street at First Street
1.b.4	Intersection Inventories – O'Brien Highway at Third Street
1.b.5	Intersection Inventories – Cambridge Street at Third Street
1.b.6	Intersection Inventories – First Street at Thorndike Street
1.b.7	Intersection Inventories - First Street at Spring Street and Upper Garage Entrance and Exit
1.b.8	Intersection Inventories – First Street at Lower Garage Entrance and Service Entrance
1.b.9	Intersection Inventories – First Street at Cambridgeside Place and Charles Street
1.b.10	Intersection Inventories - Cambridgeside Place at Lower Garage Entrance and Exit
1.b.11	Intersection Inventories - Land Boulevard at Cambridgeside Place
1.b.12	Intersection Inventories – Land Boulevard at Service Entrance and Lower Garage Entrance
1.b.13	Intersection Inventories - Land Boulevard at Binney Street
1.b.14	Intersection Inventories – Binney Street at First Street
1.b.15	Intersection Inventories – Binney Street at Second Street
1.b.16	Intersection Inventories – Binney Street at Third Street
1.b.17	Intersection Inventories – Broadway at Third Street
1.c.1	Lower Garage Level G1 Floor Plan
1.c.2	Lower Garage Level G2 Floor Plan
1.c.3	Lower Garage Level G3 Floor Plan
1.c.4	Upper Garage Level 1 Floor Plan
1.c.5	Upper Garage Level 2 Floor Plan

FIGURES (Continued)

Number	Title
1.c.6	Upper Garage Level 2.5 Floor Plan
1.c.7	Upper Garage Level 3 Floor Plan
1.c.8	Upper Garage Level 4 Floor Plan
1.c.9	Upper Garage Level 5 Floor Plan
1.c.10	Upper Garage Level 6 Floor Plan
1.c.11	Land Boulevard Service Entrance/Loading Docks
1.c.12	First Street Service Entrance/Loading Docks
1.c.13	Existing Short-Term Bicycle Parking Locations
1.c.14	Existing Long-Term Bicycle Parking
1.c.15	On-Site Short-Term Bicycle Parking and Access Map
1.c.16	Location A – Short Term Bicycle Parking
1.c.17	Location B – Short Term Bicycle Parking
1.c.18	Locations C and D – Short Term Bicycle Parking
1.c.19	Location E – Short Term Bicycle Parking
1.c.20	Location F – Short Term Bicycle Parking
1.c.21	Locations G and H – Short Term Bicycle Parking
1.d.1	Transit Map
1.d.2	Proposed First Street Connection and Proposed Lechmere Station Location
1.d.3	Bicycle Parking and Route Access Map
1.d.4	Carsharing and Ridesharing Services Map
1.d.5	Bikesharing Stations Map
1.e.1	Land Use Map
2.a.1	Count Location Map
2.c.1	2020 Existing Weekday Morning Peak Hour Traffic Volumes
2.c.2	2020 Existing Weekday Evening Peak Hour Traffic Volumes
2.c.3	2020 Existing Weekday Morning Peak Hour Pedestrian Volumes
2.c.4	2020 Existing Weekday Evening Peak Hour Pedestrian Volumes
2.c.5	2020 Existing Weekday Morning Peak Hour Bicycle Volumes

FIGURES (Continued)

Number	Title
2.c.6	2020 Existing Weekday Evening Peak Hour Bicycle Volumes
2.f.1	Lower Garage Parking Utilization Summary
2.f.2	Upper Garage Parking Utilization Summary
2.g.1	East Cambridge Area Comparable Sites
3.b.1	Office Trip Distribution Map
3.b.2	Residential Trip Distribution Map
3.b.3	Retail Trip Distribution Map
3.c.1	Third Floor Retail Trips Removed Weekday Morning Peak Hour Traffic Volumes
3.c.2	Third Floor Retail Trips Removed Weekday Evening Peak Hour Traffic Volumes
3.c.3	Third Floor Office Trips Weekday Morning Peak Hour Traffic Volumes
3.c.4	Third Floor Office Trips Weekday Evening Peak Hour Traffic Volumes
3.c.5	2020 Modified Existing Weekday Morning Peak Hour Traffic Volumes
3.c.6	2020 Modified Existing Weekday Morning Peak Hour Traffic Volumes
3.d.1	Upper Garage Relocated Trips Weekday Morning Peak Hour Traffic Volumes
3.d.2	Upper Garage Relocated Trips Weekday Evening Peak Hour Traffic Volumes
3.d.3	New Destinations for Monthly Parkers
3.d.4a	Net Non-Tenant Monthly Parkers Redistributed Weekday Morning Peak Hour Traffic Volumes
3.d.4b	Net Non-Tenant Monthly Parkers Redistributed Weekday Evening Peak Hour Traffic Volumes
3.d.5	Core Retail Trips Removed Weekday Morning Peak Hour Traffic Volumes
3.d.6	Core Retail Trips Removed Weekday Evening Peak Hour Traffic Volumes
3.d.7	Office/R&D Weekday Morning Peak Hour Traffic Volumes
3.d.8	Office/R&D Weekday Evening Peak Hour Traffic Volumes
3.d.9	Residential Weekday Morning Peak Hour Traffic Volumes
3.d.10	Residential Weekday Evening Peak Hour Traffic Volumes
3.d.11	Net New Weekday Morning Peak Hour Traffic Volumes
3.d.12	Net New Weekday Evening Peak Hour Traffic Volumes

FIGURES (Continued)

Number	Title
3.e.1	Revisions to Land Boulevard Loading Dock
3.e.2	Revisions to First Street Loading Dock
5.b.1	2020 Build Weekday Morning Peak Hour Traffic Volumes
5.b.2	2020 Build Weekday Evening Peak Hour Traffic Volumes
5.b.3	2020 Build Weekday Morning Peak Hour Pedestrian Volumes
5.b.4	2020 Build Weekday Evening Peak Hour Pedestrian Volumes
5.d.1	2025 Future Weekday Morning Peak Hour Traffic Volumes
5.d.2	2025 Future Weekday Evening Peak Hour Traffic Volumes
5.d.3	Cumulative Area Developments Impact – Weekday Morning Peak Hour Traffic Volumes
5.d.4	Cumulative Area Developments Impact – Weekday Evening Peak Hour Traffic Volumes
6.a.1	Vehicle LOS Map – Weekday Morning Peak Hour
6.a.2	Vehicle LOS Map – Weekday Evening Peak Hour
6.a.3	Vehicle Delay Change Maps – Weekday Morning Peak Hour
6.a.4	Vehicle Delay Change Maps – Weekday Evening Peak Hour
9.a.1	Existing CambridgeSide Parking Condition March
9.a.2	Existing CambridgeSide Parking Condition October
9.a.3	Existing CambridgeSide Parking Condition December
9.c.1	Proposed Project CambridgeSide Parking Condition March
9.c.2	Proposed Project CambridgeSide Parking Condition October
9.c.3	Proposed Project CambridgeSide Parking Condition December
9.d.1	Proposed Bicycle Access and Storage Plan
9.d.2	110 First Street Bicycle Parking Plan
9.d.3a	80 & 90 First Street Bicycle Parking Plan – North
9.d.3b	80 & 90 First Street Bicycle Parking Plan – South
9.d.4	20 CambridgeSide Bicycle Parking Plan
9.d.5	60 First Street Bicycle Parking Plan

FIGURES (Continued)

<u>Number</u>	<u>Title</u>
10.a.1	Future Transit and Pedestrian/Bicycle Facilities
11.a.1	Pedestrian LOS Map – Weekday Morning Peak Hour Locations Sheet 1 of 2
11.a.2	Pedestrian LOS Map – Weekday Morning Peak Hour Locations Sheet 2 of 2
11.a.3	Pedestrian LOS Map – Weekday Evening Peak Hour Locations Sheet 1 of 2
11.a.4	Pedestrian LOS Map – Weekday Evening Peak Hour Locations Sheet 2 of 2
14.b.1	Proposed Roadway Mitigation

EXECUTIVE SUMMARY

INTRODUCTION

On behalf of New England Development (the “Applicant”), Vanasse & Associates, Inc. (VAI) has conducted a Transportation Impact Study (TIS) for the proposed redevelopment of anchor properties and parking facilities associated with the mall buildings at CambridgeSide in East Cambridge (the “Project”). This study reviews the potential transportation impacts, defines site access requirements, and identifies strategies to reduce traffic impacts associated with the Project. The study also reviews the Project with respect to the City of Cambridge Special Permit Criteria regarding traffic impacts, is in accordance with the City’s guidelines for TIS, and follows the scoping determination dated March 30, 2020.

PROJECT DESCRIPTION

The Project involves the retention of a core retail business with the redevelopment of anchor buildings to create a mixed-use development providing Office/Research & Development (R&D), Retail, and Residential uses on the Site. The Project will maintain active retail and office uses, as well as the public sky-lit atrium open space within the core retail area. The former anchor store buildings and the existing Upper Garage are proposed to be redeveloped, resulting in an addition of approximately 575,000 square feet (sf) of Net New Gross Floor Area (GFA) as permitted by the Planned Unit Development 8 District (PUD-8) zoning ordinance. The development will expand the existing approximately 1.090 million sf to an approximately 1.665 million sf of mixed-use development. Approximately 175,000 net new GFA of that total will be devoted to residential uses while 400,000 net new GFA will be devoted to commercial uses, currently anticipated to include a combination of office/R&D, restaurant, and retail uses. All parking for the Project will, upon final completion of the Project, be accommodated in the Lower Garage, accessed from Land Boulevard, CambridgeSide Place, and First Street.

CONSISTENCY WITH PLANNING STUDIES

The Project has been designed to be generally consistent with the various policy plans and development guidelines applicable to the site, including those set forth in the Eastern Cambridge Planning Study dated October 2001, the guidance provided in the Eastern Cambridge Design Guidelines dated October 15, 2001, the East Cambridge Riverfront Plan dated May 1978, the East Cambridge Development Review Process and Guidelines dated June, 1985 and the Cambridge

Riverfront Plan dated Spring 2011, which support the development of beneficial and complementary uses throughout the City. Building on these various urban design studies and guidelines, the Project will enhance the public realm with a design that embraces pedestrian-oriented uses, opening new doors to the streets that surround it, and inviting community engagement with the arts and events on its streets, along the Canal and on to the Charles River.

The Project has also been designed to be consistent with the City's transportation planning efforts and projects to improve mobility in the surrounding area and region, including the Kendall Square Mobility Task Force, 2015 Transit Strategic Plan, Vision Zero Plan and Cambridge Bicycle and Pedestrian Plans, with a particular focus on initiatives to improve north-south connections on First Street. The Project also aligns with the Envision Cambridge Vision and Core Values, particularly related to Livability, as well as the Mobility Chapter.

EXISTING CONDITIONS

A field inventory of existing study area roadways was conducted to document traffic conditions in the current 2020 analysis year. Items collected regarding the study area roadways and intersections include roadway geometrics, traffic control devices, traffic signal timing plans, traffic volumes, vehicle queues, pedestrian crossing volumes, bicycle volumes, and safety data for the roadways in the vicinity of the Site. Transportation information and data used in this study were collected during May 2018, March 2019, and March 2020 and supplemented with garage data from March 2019, October 2019, and December 2019. Traffic volumes were measured by means of ATR counts and substantiated by manual intersection turning-movement and vehicle-classification counts. Other transportation-related data inventoried included on-street parking regulations, transit services, and provision of bicycle and pedestrian facilities. All traffic count information was collected prior to the COVID-19 outbreak.

PROJECT-GENERATED TRAFFIC

The Project involves the retention of a a core retail business with the redevelopment of anchor buildings to create a mixed-use development providing Office/Research & Development (R&D), Retail, and Residential uses on the Site. Trip generation rates were empirically-derived from monitoring reports for Office/R&D and Residential developments in the East Cambridge area. These rates were developed in coordination with the Cambridge Traffic, Parking, & Transportation (TP&T) Department, due to recognition of observed driveway counts and resulting trip-generation rates that are considerably lower in Cambridge than those suggested by Institute of Transportation Engineers (ITE) data. The trip generation calculated for the Third Floor Re-Tenancing Project was approved as part of that project's TIS in November 2018 (the "Third Floor TIS"). These trips are incorporated with minor revisions to trip distribution and are utilized in the Modified Baseline Condition.

Empirically-derived trip rates were used with mode split data from area office/R&D and residential developments to calculate person trips among the various transport modes. This was combined with estimates of trip reductions due to decreased retail space and the phased withdrawal of non-tenant parking activities that have been permitted at CambridgeSide through the Commercial Parking Facility Permit which is also proposed to be amended as part of the Project. As requested by the TP&T Department, garage counts from 2019 (indicating a reduction in retail activity since the submittal of the Third Floor TIS) were utilized in this analysis. The Project is expected to generate a net new increase of 1,114 vehicle trips (555 in and 559 out) on an average weekday. On an hourly basis, the site is expected to generate a net new increase of 132 vehicle trips (102 in and 30 out)

during the weekday morning peak hour and a net new increase of 92 vehicle trips (30 in and 62 out) during the weekday evening peak hour. These totals account for changes in traffic patterns due to the withdrawal of some non-tenant monthly parkers from the parking garages on site and their potential new destinations of other area parking garages or elimination due to increased TDM participation.

As compared with existing conditions, the Project results in a minimal increase in trip generation during an average weekday, weekday morning peak hour, and weekday evening peak hour time periods. In addition, the changes in use will result in decreases in traffic activity during the weekend time periods, lessening Saturday and Sunday traffic flow on the adjacent regional roadways.

ARTICLE 19 PROJECT REVIEW SPECIAL PERMIT CRITERIA ANALYSIS

As required by Section 19.20 of the City of Cambridge Zoning Ordinance (the “Ordinance”), the Project has been evaluated against the five Project Review Special Permit Criteria indicators as measurements of the Project’s expected impact on City traffic. Of the 379 measurements analyzed in connection with the five indicators, only 10 were exceeded as a direct result of the Project. A total of 10 measurements are exceeded under existing conditions and would be considered exceedances of the measurements with or without the Project. The Applicant is committed to the implementation of the Project mitigation strategies described in this TIS to lessen any potential impact of the Project on City traffic. Accordingly, the Project is not expected to have a substantial adverse impact on City traffic and issuance of a Project Review Special Permit is appropriate with respect to potential traffic impacts.

PUD-8 SPECIAL PERMIT ANALYSIS

In compliance with the Transportation Plan and Shared Parking Study components of a PUD-8 Special Permit application set forth in Sections 13.102.3(k) and 13.106.5 of the Ordinance, this TIS includes (1) a Transportation Impact Study, (2) a Shared Parking Study, (3) a study of the impacts of increased demand on public transportation services in the East Cambridge area; (4) a description the development’s relationship to future regional rail, bus, pedestrian/bicycle and other transportation system connections in the area; and 5) a Transportation Demand Management (TDM) and Mitigation program describing measures which may incorporated by the Planning Board into a condition of a PUD-8 Special Permit to offset or mitigate the development’s impacts on transportation systems. This TIS also includes a description and plans identifying the location of all parking facilities, bicycle parking facilities and loading/service facilities, as well as the number of spaces at each location, and a detailed explanation of any restrictions or commitments applicable to the existing parking facilities in compliance with the Parking and Loading Plan component of a PUD-8 Special Permit set forth in Section 13.102.3(c) of the Ordinance. As detailed in this TIS, the Project will not have a substantial adverse impact on City traffic and the Applicant is committed to implementing appropriate TDM and mitigation measures to offset any potential impacts of the Project on the surrounding street network, and therefore, it is appropriate for the City to issue a PUD-8 Special Permit for the Project.

TRAFFIC OPERATIONS ANALYSIS

To assess the impact of the Project on the roadway network, traffic operations and vehicle queue analyses were performed at the study intersections under 2020 Existing, 2020 Build and 2025 Build

conditions. The analysis indicates that the Project will not have a significant effect on operating conditions at the area intersections.

PARKING ANALYSIS

The garages on-site currently experience a peak utilization that is approximately half of total capacity. All parking for the Project will be accommodated in the Lower Garage as the Upper Garage will be removed to construct a portion of the Project. The demand for retail parking is expected to be reduced commensurate with the redevelopment of the anchor stores. As detailed in Section 9.4 below, a Shared Parking Study conducted for the Project indicates that adequate capacity will generally exist to accommodate the future parking demands of the site, including those from the committed long-term non-tenant monthly parking spaces detailed in Section 9.2 below and the proposed Retail, Residential, and Office/R&D land uses that comprise the Project described in Section 9.3 below. Any shortfalls that may exist during peak demand periods will be rectified through either the use of parking optimization systems or through a managed parking environment in accordance with Section 13.106.2 of the Ordinance. The Garage Operations team will continue to ensure that adequate parking supply is available to meet demands throughout construction and operation, as it has for the last 30 years.

With increases in capacity of nearby transit services, nearby residential developments coming online, and the potential for further expansions of the area pedestrian and bicycle network, less demand for parking facilities in the long term is anticipated. The Project will continue to provide parking availability for all current users without changes in the short term, as the development will be developed in stages over a multi-year period. As new buildings are completed over time, non-tenant monthly parking at the site, other than the committed long-term non-tenant monthly parking spaces detailed in Section 9.2 below, will be gradually phased out over a multi-year period, which is expected to provide up to 630 parking spaces on-site on an average weekday basis. While only some of these non-tenant monthly parkers are anticipated to use alternative parking destinations to continue to come to the area, 100 percent of them have been incorporated into the future traffic analysis even though many are expected to use TDM or switch to transit to continue their commute by means other than driving to East Cambridge. This has also been incorporated into analysis that shows adequate capacity exists on the transit services to accommodate the future increased demands.

The Applicant is committed to implementing a 0.9 space per 1,000 sf maximum parking ratio for the office uses and 0.8 spaces per 1,000 sf for the R&D uses, which is consistent with the PUD-8 District for the site and also with parking ratios proposed for Kendall Square and the Volpe Center development areas for office uses. Due to the elimination of the anchor stores, which in the past may have functioned as destination-type retail, it is expected there will be a reduced need for retail parking use; therefore a 0.7 space per 1,000 sf parking ratio for the retail uses is proposed. It is currently anticipated that residential parking spaces will be provided at a rate of 0.75 spaces per unit.

The Commercial Parking Facility Permit in place at the site is proposed to be amended in connection with the Project. While the Lower Garage will remain a commercial facility, restrictions limiting the number of vehicles permitted to enter the garage prior to 10:00 AM on weekdays are proposed to be lifted to be consistent with entering demands of the Project's Office/R&D uses and to update elements of the Permit that no longer apply. The Project will seek the approval of the Director of the TP&T Department for the proposed modifications to the Permit, as detailed in Section 9.6 of this TIS.

Considering the reduced demand for retail-oriented parking spaces due to the loss of retail space, the phased removal of non-tenant monthly parking, other than the committed long-term non-tenant monthly parking spaces detailed in Section 9.2 below, and the proposed parking ratios, the Project supply will be able to accommodate the projected demand (including the committed spaces), even with the removal of the Upper Garage.

The Project will also provide an additional 494 bike parking spaces for tenants' employees, residents, and visitors. This will bring a total of 640 bike parking spaces available on site.

PROJECT MITIGATION

Generally, the Project's location near transit facilities such as Lechmere Station as well as the area shuttle services significantly encourages transit use by employees, residents and visitors to the proposed Project. Mitigation efforts are therefore geared towards measures to improve traffic congestion on these adjacent streets as well as efforts to encourage Project employees and residents towards alternative transportation that would result in a low single occupant vehicle (SOV) rate for the Project. To improve traffic flow on roadways adjacent to the Project, improvements consisting of signal equipment upgrades along with signal retiming efforts and pedestrian enhancements at locations closest to the Project is proposed. The Applicant has also committed to contributing funds to be used towards a corridor study of First Street and Second Street to assist the City in determining appropriate and feasible improvements. Additionally, the Project proposes implementation of a TDM Plan and modifications to improve roadway and pedestrian facilities that outweigh any potential adverse impacts of the Project on the surrounding street network.

Section 14.0 of this TIS provides a detailed explanation of proposed TDM and mitigation measures, as well as proposed timing for implementation of the same in connection with the Project.

INTERSECTION UPGRADES

The intersection of Land Boulevard with Cambridgeside Place and the Hotel Sonesta driveway has older pedestrian signal equipment and non-American with Disabilities Act (ADA)-compliant wheelchair ramps. Accordingly, it is recommended that the traffic signal equipment at this location be replaced with the latest technology, including hybrid video/radar cameras for detection of pedestrians, bicycles, and vehicles to provide a fully-actuated traffic signal. This equipment will allow the constant optimization of green time for approaches that have most demand.

MITIGATION STAGING

The Scoping Letter requested a description of how transportation mitigation measures could be linked to milestones, thresholds, or performance standards as the Project develops in multiple stages.

This TIS proposes mitigation that addresses the impacts of the entire Project. The Applicant will provide the City with interim traffic reporting as various components of the Project are completed, including the results of traffic and parking counts before and after each stage of the development is occupied. In this way, the status of the Project's TDM efforts to constrict the parking supply, reduce SOV percentages, and encourage the use of alternative transportation can be monitored. It is anticipated that the Traffic, Parking, & Transportation Department and the Community Development Department may have additional input into this monitoring reporting process, and the Applicant will meet to discuss and review any concerns and comments Staff may have.

It should be noted that the Applicant has a vested interest in ensuring the success of the transportation system in the immediate area. Accordingly, the mitigation measures identified in Section 14.0 below are provided as means to validate the intentions of the Applicant towards improvements to the transportation system.

ADDITIONAL MITIGATION MEASURES

Consistent with efforts to minimize the generation of SOV trips and to also provide better management of existing traffic congestion while improving surface transit reliability and service, the following additional mitigation measures have been identified:

- **FIRST STREET AND SECOND STREET CORRIDOR STUDY** – As discussed with TP&T, CambridgeSide will contribute funds to be used towards a corridor study of First Street and Second Street that could review feasibility of road features such as bus priority lanes on First Street, dedicated bicycle lanes on Second Street, use of street frontage for ride-hailing service parking, parklets, and other curb-oriented uses.
- **BLUEBikes SPONSORSHIP** – Expands CambridgeSide’s participation in the Bluebikes program and provides Gold-level corporate membership in Bluebikes for a 10-year period for all tenants.
- **EAST CAMBRIDGE TRANSIT EXPANSION PROGRAM** – Monetary contribution to the City of Cambridge intended as an initial funding level to be used for funding the review of local transit improvements, such as funds towards the Grand Junction Rail with Trail, a Lechmere to Kendall Shuttle, and any future MBTA bus service that may use the corridor.
- **TRANSIT SUBSIDIES** – CambridgeSide will direct tenants to provide Transit Subsidies to tenants’ employees for use towards transit passes (MBTA and EZRide), BLUEbikes programs, and parking charges at Park & Ride lots.
- **EXPANDED CAMBRIDGESIDE SHUTTLE BUS OPERATIONS** – Anticipation of expansion to CambridgeSide Shuttle between New Lechmere Station, Kendall Square Station, and site.
- **POTENTIAL EZRIDE SHUTTLE BUS CONSOLIDATION** – Review of consolidation of EZRide shuttle services with CambridgeSide Shuttle route to provide expanded shuttle services and cross connections with EZRide stops including North Station and Central Square.

TRANSPORTATION DEMAND MANAGEMENT MEASURES

CambridgeSide currently provides a number of Transportation Demand Management (TDM) measures consistent with local conditions of the original CambridgeSide approval that were intended to reduce SOV travel and encourage the use of alternative modes of transportation. The measures are provided below in *italics* with the current status also provided.

- *Provide details of a shuttle bus system including routes, schedules, frequency and capacity serving the development, other developments and the East Cambridge transit stations –*

Currently implemented through both the Charles River TMA EZ Ride shuttle bus system providing service between Kendall Square and North Station as well as the CambridgeSide Shuttle Bus that provides service between CambridgeSide and Kendall Square free of charge.

- *Implement a computer based ride sharing information bank to assist commuters seeking van pool and car pool arrangements* – Currently implemented through membership in the Charles River TMA.
- *Plan for participation in the MBTA commuter pass program for all employees and tenants of this development* – Previously implemented with employees, tenants, and visitors able to purchase MBTA passes at the CambridgeSide information desk. The MBTA is in the process of revising their technology for point of sale pass purchase and this service is temporarily unavailable.
- *Provide details of an on-going program to survey customers and employees (including tenants) to determine travel modes, times of arrival and departure, home location, and preferences for ride sharing among other information* – Currently implemented as the Annual Transportation Monitoring Report.
- *Allow for up to 50 percent of the bicycle parking facilities required by Article 6.000 to be located elsewhere in the East Cambridge riverfront district in public parks and other suitable locations* – Currently implemented through short-term bicycle parking spaces located around Canal Park and on CambridgeSide Place.

In addition to these ongoing commitments, CambridgeSide will implement the following TDM measures to supplement the existing program and encourage alternatives to SOV use by the new office employees:

- Encourage employees to obtain a Charlie card and register it for bike parking, allowing employees the ability to use the bike cages at area MBTA stations and other areas free of charge;
- Make available public transportation schedules, which will be posted in a centralized location for employees along with Transitscreens™ to be located in the lobbies of main buildings;
- Provide information on available pedestrian and bicycle facilities in the vicinity of the project site in a central location for employees;
- Charge for parking at market rates and offer discounted parking for dedicated HOV vehicles;
- Provide language in lease documents ensuring that employers are required to provide MBTA pass subsidies to employees up to the federal maximum (currently \$270 per month);
- Provide information about transportation options available to employees at orientations and on a company website; and
- Encourage employers to work with the Cambridge Office of Workforce Development.

CONCLUSION

As required by the City, the Project's impact has been measured against 5 criteria as indicators of the Project's impact. Of the 379 measurements analyzed in connection with the five indicators, only 10 were exceeded as a direct result of the Project. A total of 10 measurements are exceeded under existing conditions and would be considered exceedances of the measurements with or without the Project.

The Project is a redevelopment of an existing, once-thriving, retail facility. By providing additions of Office/R&D and Residential land uses while retaining core retail and restaurant uses, the site will be transformed into a mixed-use development that is able to benefit from nearby transit and alternative transportation services and reduce the overall traffic impact of the Project. In order to reduce any potential impacts of the Project, the Applicant proposes implementation of the above-described mitigation measures, including continued TDM strategies, the expansion of the CambridgeSide shuttle bus and potential consolidation with the EZRide shuttle services and providing funds for additional study of Transit Expansion and the First Street corridor to improve traffic conditions in the area. Improved traffic signal technologies designed to address current congestion in the area will also be implemented to further reduce the Project's impact on the area road network. The Project will also provide minimal parking ratios and expanded bicycle parking and storage, all measures that are proven to reduce the demand for personal vehicles. These benefits are substantial and will address existing congestion and reduce the overall effect of the Project, ensuring the viability of CambridgeSide and continuing the role of CambridgeSide as an active, vibrant, and stable attraction in East Cambridge.

The Project location close to expanded transit services and transit connectivity will further reduce the overall traffic impact of the Project. The Project will also significantly improve the pedestrian and bicycle connectivity and experience at the site through widened sidewalks and improved conditions (e.g., lighting), encouraging increased usage of these alternative modes of transportation. The proposed Project will not result in a public hazard due to substantially increased vehicular traffic or parking in this area of East Cambridge. Specifically, the Project is not anticipated to have a significant adverse impact on motorist delays in the area and adequate parking supply will exist at the site. Accordingly, **this TIS finds that the Project can be accommodated within the existing area infrastructure and on the roadway network with minimal effects, resulting in the ability to implement the Project's planned mix of uses with the appropriate mitigation measures.**

INTRODUCTION

Vanasse & Associates, Inc. (VAI) has conducted a Transportation Impact Study (TIS) for the Project as described above. This study reviews the potential transportation impacts, defines site access requirements, and identifies strategies to reduce traffic impacts associated with the Project. The study also reviews the Project with respect to the City of Cambridge Special Permit Criteria regarding traffic impacts, is in accordance with the City’s guidelines for TIS, and follows the scoping determination dated March 30, 2020. Table 1.a.1 outlines the existing and proposed building area characteristics of the Project, and is intended to explain the Project building areas as they relate to the calculation of Net New Gross Floor Area (GFA) as defined in the zoning for the PUD-8 parcel.

**Table 1.a.1
PROJECT BUILDING AREA CHARACTERISTICS**

Characteristics	Office	R&D
Sears, approx. sf	--	165,000
Upper Garage, approx. sf	85,000	--
Best Buy, approx. sf	95,000	205,000
Macy’s, approx. sf	30,000	295,000
Core Retail Area, approx. sf	140,000	--
SUBTOTAL COMMERCIAL	350,000	665,000
Retail, approx. sf	375,000 (half of existing retail)	
Residential, approx. sf/units	175,000 (200 units)	
TOTAL PROJECT GLA, approx. sf	1,565,000	
Common Areas, approx. sf	100,000	
TOTAL PROJECT GFA, approx. sf	1,665,000	
Existing GFA, approx. sf (retail and common areas)	1,090,000	
NET NEW GFA, approx. sf	575,000	

Table 1.a.2 outlines the existing and proposed parking characteristics of the Project.

Table 1.a.2
PROJECT PARKING CHARACTERISTICS

<u>Parking Characteristics</u>	<u>Existing Site</u>	<u>Proposed Project</u>	<u>Net Change</u>
Upper Garage	795	0	-795
<u>Lower Garage</u>	<u>1,695</u>	<u>1,695</u>	<u>0</u>
Total	2,490	1,695	-795
Bicycle Spaces	146	494	640

The Project preliminary ground floor plan with points of vehicle access are shown on Figure 1.a.1, while the preliminary ground floor plan with points of pedestrian access is depicted in Figure 1.a.2. A survey plan is shown in Figure 1.a.3 including property lines, abutting parcels, and property ownership with easements also depicted.

1.0 EXISTING CONDITIONS

1.1 EXISTING TRAFFIC CONDITIONS

A field inventory of existing study area roadways was conducted to document traffic conditions in the current 2020 analysis year. Items collected regarding the study area roadways and intersections include roadway geometrics, traffic control devices, traffic signal timing plans, traffic volumes, vehicle queues, pedestrian crossing volumes, bicycle volumes, and safety data for the roadways in the vicinity of the site. Transportation information and data used in this study were collected during May 2018, March 2019, and March 2020 and supplemented with garage data from March 2019, October 2019, and December 2019.

1.2 DESCRIPTION OF PROJECT STUDY AREA

The Project study area was determined in consultation with City transportation officials. The study area was confirmed in the March 30, 2020 Scoping Determination from the City to VAI. The study area is listed below.

1. Land Boulevard at Cambridgeside Place and Hotel (Sonesta) Driveway
2. O'Brien Highway at Museum Way
3. O'Brien Highway at Land Boulevard and Charlestown Ave
4. O'Brien Highway at Cambridge Street and East Street
5. O'Brien Highway at Third Street
6. Cambridge Street at Third Street
7. Cambridge Street at First Street
8. First Street at Cambridgeside Place and Charles Street
9. Land Boulevard at Lower Garage East Entrance
10. Cambridgeside Place at Lower Garage South Entrance
11. Cambridgeside Place at Lower Garage South Exit
12. First Street at Thorndike Street
13. First Street at Lower Garage West Entrance
14. First Street at Upper Garage Entrance/Exit and Spring Street
15. Binney Street at Land Boulevard
16. Binney Street at First Street
17. Binney Street at Second Street
18. Binney Street at Third Street
19. Third Street at Broadway

Transportation Network

Access to the area is provided via McGrath/O'Brien Highway, Land Boulevard, and Memorial Drive, all of which connect to the general street network surrounding the site. These roadways provide connections to regional roadways such as Massachusetts Turnpike and Interstate 93 (I-93), as well as connections into downtown Cambridge and Boston. Local access to the site is provided from Land Boulevard, First Street, and Cambridgeside Place.

Geometric and Traffic Control

Existing intersection geometry and lane usage was obtained from field inventory and observations conducted by VAI in 2019 and updated in March 2020. A graphical depiction of intersection inventories for the study area intersections are provided in Figure 1.b.1 through Figure 1.b.17. The Service Entrances for the site, accessed from Land Boulevard and First Street, are shown on Figure 1.b.8 and Figure 1.b.12, respectively. Sidewalks and wheelchair ramps along Cambridgeside Place and First Street are in fair to good condition. Bike lanes currently exist on First Street and Binney Street.

1.3 PARKING AND LOADING FACILITIES

Figure 1.c.1 through Figure 1.c.10 provides images of the Upper and Lower Garages. Figure 1.c.11 and Figure 1.c.12 depict the Land Boulevard and First Street loading docks, respectively. Locations of short-term and long-term bicycle parking are indicated on Figure 1.c.13 and Figure 1.c.14, respectively. The locations of on-site short-term bicycle parking and bike access to the site are shown in Figure 1.c.15. Scaled plans (1 inch = 10 feet) of the short-term bicycle parking spaces within the Project bounds are depicted in Figure 1.c.16 through Figure 1.c.20. Additional images that depict the locations where other short-term bicycle racks have been installed by the Applicant but not on property controlled by the Applicant are shown on Figure 1.c.21.

1.4 TRANSIT SERVICES

Existing transit and bike facilities have been researched and inventoried in March 2020. Figure 1.d.1 provides a graphical depiction of the regional public and private transportation services available in the area, including the Cambridgeside Shuttle Bus service. Figure 1.d.2 depicts the proposed First Street Extension across Cambridge Street and Monsignor O'Brien Highway to the North Point site and the proposed location of the new Lechmere Station. Figure 1.d.3 shows the bicycle parking and route access map for bicycle facilities in the area. Figure 1.d.4 provides a Carsharing and Ridesharing Services Map highlighting nearby locations of taxi stands and carsharing services such as Zipcar. Figure 1.d.5 provides a Bikesharing Station Map that identifies locations of BLUEbikes stations in the area.

1.5 LAND USE

Land uses in the vicinity of the site were researched and inventoried in March 2020 and are shown in Figure 1.e.1.

2.0 DATA COLLECTION

2.1 AUTOMATIC TRAFFIC RECORDER COUNTS

To establish existing traffic conditions within the study area, ATR counts and manual turning movement and vehicle classification counts were conducted in May 2018 and March 2019 and adjusted to 2020 traffic volume conditions. This allowed for public schools to be in regular session at the time the data was collected. The traffic count data sheets are provided in the Appendix. A summary of the ATR data is provided in Table 2.a.1, while the average hourly directional volumes recorded at the ATR locations are summarized in Table 2.a.2. The location of the counts and the date the counts were conducted are shown on Figure 2.a.1.

**Table 2.a.1
2020 BASELINE TRAFFIC VOLUMES**

Location	Weekday ADT ^a	Morning Peak Hour			Evening Peak Hour		
		Vehicles Per Hour	K Factor ^b	Directional Distribution ^c	Vehicles Per Hour	K Factor	Directional Distribution
Land Boulevard, north of Cambridgeside Place	38,000	2,358	6.2	71% SB	2,418	6.4	58%, NB
Cambridgeside Place, west of Land Boulevard	6,500	446	6.9	76% WB	728	11.2	69%, EB
First Street, south of Spring Street	7,000	503	7.2	61% NB	532	7.6	65% NB

Source: ATRs counts conducted in May 2018 and TMCs conducted in March 2019 and adjusted to 2020 levels.

Note: SB = Southbound; NB = Northbound; WB = Westbound; EB = Eastbound.

^aTwo-way daily traffic expressed in vehicles per day

^bTwo-way peak-hour volume expressed in vehicles per hour.

^cPercent of daily volume in peak hour.

^dPercent traveling in the peak direction.

Table 2.a.2
AVERAGE HOURLY TRAFFIC VOLUMES AT ATR LOCATIONS^a

Start Time	Land Boulevard, North of Cambridgeside Place			Cambridgeside Place, West of Land Boulevard			First Street, South of Spring Street		
	NB	SB	Total	EB	WB	Total	NB	SB	Total
12:00 AM	290	154	443	30	18	48	16	12	28
1:00	148	97	245	12	7	19	18	13	31
2:00	115	63	178	6	10	16	11	3	14
3:00	62	99	161	6	8	14	12	8	20
4:00	105	271	376	7	10	17	11	8	19
5:00	228	1032	1261	17	39	57	31	39	71
6:00	449	1390	1839	42	76	118	95	74	169
7:00	696	1580	2276	91	79	170	156	165	320
8:00	735	1623	2358	111	162	273	261	194	455
9:00	853	1495	2348	107	149	257	270	199	469
10:00	885	1171	2055	133	155	288	222	155	377
11:00	915	1071	1986	163	187	349	223	111	334
12:00 PM	1080	980	2059	208	152	360	250	155	405
1:00	1233	885	2118	270	160	429	262	133	395
2:00	1341	942	2284	282	149	431	422	125	547
3:00	1243	1113	2356	270	155	424	484	120	604
4:00	1271	1103	2374	359	148	507	340	243	584
5:00	1166	954	2120	439	111	550	212	227	439
6:00	1330	922	2252	377	166	542	393	206	599
7:00	1245	774	2019	291	166	457	265	145	410
8:00	1066	588	1653	295	134	429	221	127	348
9:00	997	523	1520	256	103	359	190	82	272
10:00	749	415	1165	118	69	187	74	51	124
11:00	<u>651</u>	<u>270</u>	<u>921</u>	<u>43</u>	<u>25</u>	<u>69</u>	<u>47</u>	<u>23</u>	<u>71</u>
Total ^b	18853	19515	38367	3933	2438	6370	4486	2618	7105

Note: SB = Southbound; NB = Northbound; WB = Westbound; EB = Eastbound.

^aVolumes based on ATR counts conducted by VAI in May 2018 and adjusted to 2020 levels; expressed in vph.

^bDaily volumes expressed in vpd.

2.2 PEDESTRIANS

Pedestrian and bicycle counts for the study area intersections were collected during the vehicle count periods of 2018 described above and adjusted to 2020 conditions by applying a 0.5 percent annual growth rate. The twelve-hour pedestrian counts were performed on Cambridgeside Place, First Street, and Land Boulevard at the ATR locations with the twelve-hour average hourly pedestrian summaries provided in Table 2.b.1 through Table 2.b.3 for the respective locations. All counts were conducted in clear weather. The counts indicate that the majority of the pedestrians on Cambridgeside Place use the north side of the roadway. Counts of First Street indicate the majority of pedestrians use the east side of the roadway. Counts of Land Boulevard indicate a more balanced distribution for pedestrians traveling northbound while pedestrians traveling southbound mostly use the west side of the street.

In the vicinity of the Site, all study streets provide 7- to 12-foot wide concrete sidewalks on both sides of the roadway. At intersections where crosswalks are marked, wheelchair ramps are provided at each crosswalk located across each leg of the intersection.

**Table 2.b.1
AVERAGE HOURLY PEDESTRIAN VOLUMES^a
CAMBRIDGESIDE PLACE**

Time	Eastbound		Westbound		Northbound	Southbound
	North Side	South Side	North Side	South Side	Crossing Cambridgeside Place	Crossing Cambridgeside Place
7:00 AM	17	1	29	7	15	117
8:00	41	0	105	8	41	258
9:00	45	2	63	11	49	205
10:00	33	3	68	7	69	120
11:00	44	2	70	0	129	109
12:00 PM	96	6	128	3	282	316
1:00	77	2	156	2	168	295
2:00	106	11	122	5	101	157
3:00	78	4	94	3	89	106
4:00	109	8	119	6	180	78
5:00	194	12	134	1	267	93
6:00	173	5	126	5	115	109
Total	1013	56	1214	58	1505	1963

^aBased on counts conducted by VAI in May 2018 adjusted to 2020 levels.

Table 2.b.2
AVERAGE HOURLY PEDESTRIAN VOLUMES^a
FIRST STREET

Time	Northbound		Southbound		Eastbound	Westbound
	East Side	West Side	East Side	West Side	Crossing First Street	Crossing First Street
7:00 AM	14	12	40	32	3	7
8:00	46	23	82	42	0	3
9:00	40	10	77	46	3	5
10:00	37	13	44	26	10	5
11:00	43	36	49	52	1	3
12:00 PM	119	63	101	100	7	4
1:00	117	52	105	27	10	4
2:00	70	22	73	31	5	0
3:00	84	53	67	22	5	1
4:00	111	61	57	24	5	9
5:00	144	84	85	63	6	1
6:00	88	45	90	57	3	4
Total	913	474	870	522	58	46

^aBased on counts conducted by VAI in May 2018 adjusted to 2020 levels.

Table 2.b.3
AVERAGE HOURLY PEDESTRIAN VOLUMES^a
LAND BOULEVARD

Time	Northbound		Southbound		Eastbound	Westbound
	East Side	West Side	East Side	West Side	Crossing Land Boulevard	Crossing Land Boulevard
7:00 AM	40	35	23	69	1	3
8:00	36	38	79	142	2	5
9:00	18	23	28	90	0	8
10:00	18	14	19	36	0	2
11:00	15	20	16	32	4	2
12:00 PM	16	41	46	76	4	4
1:00	38	30	49	67	2	5
2:00	43	34	31	31	4	5
3:00	46	40	53	29	1	0
4:00	89	86	49	52	3	2
5:00	115	126	62	94	6	2
6:00	55	114	53	71	1	3
Total	529	601	508	789	28	41

^aBased on counts conducted by VAI in May 2018 adjusted to 2020 levels.

2.3 BICYCLES

As with the pedestrian counts, bicycle counts for the study area intersections were collected during the peak-hour vehicle count periods of 2018 described above and adjusted to 2020 conditions by applying a 0.5 percent annual growth rate. Twelve-hour bicycle counts were also collected at the ATR locations on Cambridgeside Place, First Street, and Land Boulevard with the twelve-hour average hourly bicycle summaries provided in Table 2.b.4 through Table 2.b.6 for the respective locations. The counts were conducted in clear weather.

Of the three streets, First Street carries the highest number of bicycles with most traveling southbound.

**Table 2.b.4
AVERAGE HOURLY BICYCLE VOLUMES^a
CAMBRIDGESIDE PLACE**

Time	Eastbound	Westbound	Crossing Cambridgeside Place	
			Northbound	Southbound
7:00 AM	1	3	0	0
8:00	1	9	0	5
9:00	7	3	0	3
10:00	1	1	0	1
11:00	0	2	4	2
12:00 PM	7	6	1	3
1:00	1	6	0	0
2:00	4	3	0	0
3:00	5	1	1	1
4:00	7	7	0	0
5:00	9	8	3	2
<u>6:00</u>	<u>6</u>	<u>4</u>	<u>0</u>	<u>0</u>
Total	49	53	9	17

^aBased on counts conducted by VAI in May 2018 adjusted to 2020 levels.

Table 2.b.5
AVERAGE HOURLY BICYCLE VOLUMES^a
FIRST STREET

Time	Northbound	Southbound	Crossing First Street	
			Eastbound	Westbound
7:00 AM	8	10	0	1
8:00	19	35	0	0
9:00	15	25	0	0
10:00	7	4	0	0
11:00	7	6	0	0
12:00 PM	4	13	0	0
1:00	7	5	0	0
2:00	5	7	0	0
3:00	6	11	0	0
4:00	9	14	0	0
5:00	26	19	0	0
<u>6:00</u>	<u>11</u>	<u>17</u>	<u>0</u>	<u>0</u>
Total	124	166	0	1

^aBased on counts conducted by VAI in May 2018 adjusted to 2020 levels.

Table 2.b.6
AVERAGE HOURLY BICYCLE VOLUMES^a
LAND BOULEVARD

Time	Northbound	Southbound	Crossing Land Boulevard	
			Eastbound	Westbound
7:00 AM	3	11	0	0
8:00	4	35	0	0
9:00	6	8	0	0
10:00	4	1	0	0
11:00	1	6	0	0
12:00 PM	5	2	0	0
1:00	2	3	0	0
2:00	6	6	0	0
3:00	10	5	0	0
4:00	17	6	0	0
5:00	21	10	0	0
<u>6:00</u>	<u>14</u>	<u>13</u>	<u>0</u>	<u>0</u>
Total	93	106	0	0

^aBased on counts conducted by VAI in May 2018 adjusted to 2020 levels.

2.4 INTERSECTION TURNING MOVEMENT COUNTS

Intersection turning movement counts were conducted at the study area intersections for the weekday morning (7:30 to 9:30 AM) and weekday evening (4:30 to 6:30PM) time periods. Total cars, trucks, buses, pedestrians by movement, bicycles, and vehicle queues were recorded. The 2020 Existing weekday morning and weekday evening peak-hour traffic-volume networks are depicted on Figure 2.c.1 through Figure 2.c.2. The pedestrian volumes are depicted in Figure 2.c.3 through Figure 2.c.4 for the weekday morning and weekday evening peak-hour periods. Bicycle volumes include both bicycles traveling on and off the sidewalks are provided in Figure 2.c.5 through Figure 2.c.6 for the weekday morning and weekday evening peak-hour periods.

2.5 EXISTING VEHICLE QUEUES

Vehicle queues were observed at the signalized intersections within the study area. Table 2.c.1 summarizes the vehicle queue observations by intersection approach and lane.

Table 2.c.1
EXISTING QUEUE OBSERVATIONS

Intersection/Lane ^b	Weekday Morning Peak Hour		Weekday Evening Peak Hour	
	Average Queue	Maximum Queue	Average Queue	Maximum Queue
<i>O'Brien Highway at Museum Way:^c</i>				
O'Brien Highway EB LT/TH	3	6	4	7
O'Brien Highway EB TH	2	5	3	7
O'Brien Highway EB TH	1	1	1	4
O'Brien Highway WB TH	9	16	7	12
O'Brien Highway WB TH	8	15	10	17
O'Brien Highway WB TH/RT	11	18	11	17
Museum Way SB LT	5	9	3	5
Museum Way SB RT	1	4	2	4
<i>O'Brien Highway at Land Boulevard /Charlestown Avenue:^c</i>				
O'Brien Highway EB LT	4	11	10	16
O'Brien Highway EB LT/TH	10	14	11	17
O'Brien Highway EB TH	10	17	7	13
O'Brien Highway EB TH	8	16	5	12
O'Brien Highway EB RT	3	8	1	4
O'Brien Highway WB LT	5	9	6	8
O'Brien Highway WB LT	6	8	5	9
O'Brien Highway WB TH	7	8	9	11
O'Brien Highway WB TH	4	6	6	11
O'Brien Highway WB RT	4	8	7	11
Land Boulevard NB LT	3	7	8	16
Land Boulevard NB TH	18	20	19	19
Land Boulevard NB TH	18	21	19	19
Land Boulevard NB RT	2	16	8	16
Charlestown Avenue SB LT/TH	20	20	20	20
Charlestown Avenue SB TH/RT	20	20	20	20

*See notes at end of table.

Table 2.c.1 (Continued)
EXISTING QUEUE OBSERVATIONS

Intersection/Lane ^b	Weekday Morning Peak Hour		Weekday Evening Peak Hour	
	Average Queue	Maximum Queue	Average Queue	Maximum Queue
<i>O'Brien Highway at Cambridge Street /East Street:</i>				
O'Brien Highway EB LT	2	4	1	3
O'Brien Highway EB TH	8	13	4	8
O'Brien Highway EB TH	11	14	6	9
O'Brien Highway EB TH	12	16	7	12
O'Brien Highway EB RT	2	5	2	3
O'Brien Highway WB LT	5	12	2	6
O'Brien Highway WB LT	3	8	4	7
O'Brien Highway WB TH	2	5	6	12
O'Brien Highway WB TH/RT	2	4	8	13
Cambridge Street NB LT/TH	3	6	2	3
Cambridge Street NB RT	3	8	3	6
Cambridge Street NB RT	2	6	3	6
East Street SB LT/TH/RT	1	4	2	4
<i>Cambridge Street at First Street:</i>				
Cambridge Street EB TH/RT	3	5	10	16
Cambridge Street WB LT	2	4	5	8
Cambridge Street WB TH	1	3	4	6
First Street NB LT	2	4	5	8
First Street NB RT	2	6	6	11
<i>O'Brien Highway at Third Street:</i>				
O'Brien Highway EB TH	11	12	7	12
O'Brien Highway EB TH	11	12	7	12
O'Brien Highway EB TH/RT	11	12	5	10
O'Brien Highway WB LT/TH	2	5	6	11
O'Brien Highway WB TH	3	8	12	19
O'Brien Highway WB TH	1	3	12	19
Third Street NB LT	3	6	5	7
Third Street NB LT/RT	1	3	6	9
<i>Cambridge Street at Third Street:</i>				
Cambridge Street EB LT/TH/RT	10	13	8	13
Cambridge Street WB LT/TH/RT	4	13	9	13
Third Street NB LT/TH/RT	3	6	10	10
Third Street SB LT	1	3	1	1
Third Street SB TH/RT	9	11	4	8
<i>First Street at Thorndike Street:</i>				
Thorndike Street EB LT	1	2	2	4
Thorndike Street EB RT	1	4	2	4
First Street NB TH	1	5	17	20
First Street SB TH	5	12	6	14

*See notes at end of table.

Table 2.c.1 (Continued)
EXISTING QUEUE OBSERVATIONS

Intersection/Lane ^b	Weekday Morning Peak Hour		Weekday Evening Peak Hour	
	Average Queue	Maximum Queue	Average Queue	Maximum Queue
<i>First Street at Cambridgeside Place and Charles Street:</i>				
Charles Street EB LT/TH/RT	3	6	5	7
Cambridgeside Place WB LT/RT	2	6	8	11
First Street NB TH/RT	4	10	6	9
First Street SB LT/TH	3	7	6	10
<i>Land Boulevard at Cambridgeside Place and Hotel Driveway:</i>				
Cambridgeside Place EB LT	3	6	10	12
Cambridgeside Place EB LT/TH	3	4	8	12
Cambridgeside Place EB RT	0	0	0	0
Hotel Driveway WB LT/TH/RT	1	3	2	5
Land Boulevard NB LT	2	6	11	16
Land Boulevard NB TH	3	5	13	18
Land Boulevard NB TH	4	6	13	18
Land Boulevard NB TH/RT	3	6	4	6
Land Boulevard SB LT	9	16	4	8
Land Boulevard SB TH	10	14	6	13
Land Boulevard SB TH	10	14	8	12
Land Boulevard SB TH/RT	2	6	3	5
<i>Land Boulevard at Binney Street:</i>				
Binney Street EB LT	2	4	2	5
Binney Street EB LT	2	5	2	5
Land Boulevard NB LT	18	22	5	9
Land Boulevard NB LT	13	20	7	13
Land Boulevard NB TH	4	10	11	16
Land Boulevard NB TH	4	11	10	16
Land Boulevard NB TH	2	5	3	8
Land Boulevard SB TH	11	16	5	10
Land Boulevard SB TH	10	15	6	12
Land Boulevard SB RT	6	12	1	3
<i>Binney Street at First Street:</i>				
Binney Street EB LT	2	5	2	4
Binney Street EB TH	2	6	3	6
Binney Street EB TH/RT	2	4	3	6
Binney Street WB LT/TH	1	3	1	4
Binney Street WB TH/RT	5	8	1	4
First Street NB LT/TH/RT	4	7	1	3
First Street SB LT/TH	4	7	7	13
First Street SB RT	2	6	2	5

*See notes at end of table.

Table 2.c.1 (Continued)
EXISTING QUEUE OBSERVATIONS

Intersection/Lane ^b	Weekday Morning Peak Hour		Weekday Evening Peak Hour	
	Average Queue	Maximum Queue	Average Queue	Maximum Queue
<i>Binney Street at Second Street:^d</i>				
Binney Street EB LT	1	4	3	8
Binney Street EB TH/RT	4	7	3	11
Binney Street WB LT	2	5	1	3
Binney Street WB TH	6	11	3	6
Binney Street WB TH/RT	6	12	4	11
Second Street NB LT/TH	8	10	6	10
Second Street NB RT	2	6	1	4
Second Street SB LT/TH/RT	4	8	3	7
<i>Binney Street at Third Street:</i>				
Binney Street EB LT	2	5	6	12
Binney Street EB TH	3	11	3	10
Binney Street EB TH/RT	3	8	4	12
Binney Street WB LT	4	8	2	4
Binney Street WB TH	4	10	2	5
Binney Street WB TH/RT	4	12	3	7
Third Street NB LT/TH	3	10	6	12
Third Street NB RT	1	3	1	4
Third Street SB LT/TH/RT	9	12	6	12
<i>Broadway at Third Street:^e</i>				
Broadway EB LT	3	9	4	9
Broadway EB TH	3	7	5	10
Broadway EB TH/RT	2	4	3	7
Broadway WB TH/RT	3	5	5	7
Third Street SB TH/TH	5	9	6	9
Third Street SB RT	2	4	1	3

^aSource: Based upon observations conducted by VAI in May 2018 and March 2019.

^bEB = eastbound; WB = westbound; NB = northbound; SB = southbound; LT = left-turning movements; TH = through movements; RT = right-turning movements.

^cQueues at the intersections of O'Brien Highway at Land Boulevard and O'Brien Highway at Museum Way were recorded prior to the improvements implemented by the Massachusetts Department of Transportation (MassDOT) in 2019.

^dThe Second Street NB approach at the intersection with Binney Street is striped as a one lane approach though the queue observations show two lanes of traffic at times (a NB LT/TH lane and a NB RT Lane). For the capacity analysis this intersection was analyzed as a one lane approach.

^eDue to construction at the time of the queue observations the Broadway westbound approach was reduced to one lane. For the capacity analysis this intersection was analyzed as a two lane approach (TH lane and a RT lane)

Longfellow Bridge Traffic Effects

The 2018 traffic counts were conducted approximately one week before the Longfellow Bridge was re-opened to vehicular traffic. The intersection of Monsignor O'Brien Highway and Land Boulevard was counted in both 2018 and 2019 for review of effects due to the bridge reopening. This is shown in Table 2.c.2.

**Table 2.c.2
LONGFELLOW BRIDGE COUNT COMPARISON^a**

Peak Hour Time Period	2018 Intersection Volume, vph	2019 Intersection Volume, vph	Percent Variation
Weekday Morning	4,522	4,517	- 0.1%
Weekday Evening	4,645	4,622	- 0.5%

^aBased on intersection volume counts at intersection of O'Brien Highway and Land Boulevard conducted in May 2018 and March 2019 for the Project.

As shown, the intersection volume from 2019 is shown to be equivalent to the volume from 2018. This indicates that the intersection was processing approximately the same volume of traffic in 2018 before the project was completed as in 2019 after the bridge was opened. For the peak-hour analyses performed for this TIS and the congestion levels on Land Boulevard and O'Brien Highway, traffic-volume conditions are not likely to have been substantially altered in this area of East Cambridge as a result of the bridge re-opening.

2.6 MOTOR VEHICLE CRASH DATA

Motor vehicle crash data was obtained from the MassDOT Safety Management/Traffic Operations Unit for the most recent five-year period available (2013-2017) in order to examine motor vehicle crash trends occurring within the study area. In addition, the Cambridge Police Department (CPD) was contacted to obtain crash records from 2015-2017 at the study area intersections under their jurisdiction. The CPD provided 11 crashes from 2015-2017 that occurred at the study area intersections all of which were included in the MassDOT online database. This data is summarized in Table 2.d.1. Separate tables are provided that identify summaries of crashes between vehicles and pedestrians in Table 2.d.2 and crashes between vehicles and bicyclists in Table 2.d.3. Intersections where no pedestrian or bicyclist involvement with vehicles was recorded are not shown in Table 2.d.2 or Table 2.d.3.

**Table 2.d.1
VEHICLE CRASH DATA SUMMARY^a**

	O'Brien Highway at Museum Way	O'Brien Highway at Land Boulevard/ Charlestown Avenue	O'Brien Highway at Cambridge Street/ East Street	Cambridge Street at First Street	O'Brien Highway at Third Street	Cambridge Street at Third Street	First Street at Thorndike Street
<i>Year:</i>							
2013	4	14	5	2	4	4	0
2014	2	14	6	4	2	4	1
2015	6	19	9	5	6	6	1
2016	4	17	8	2	5	3	1
<u>2017</u>	<u>7</u>	<u>11</u>	<u>6</u>	<u>1</u>	<u>4</u>	<u>6</u>	<u>2</u>
Total	23	75	34	14	21	23	5
Average ^b	4.6	15.0	6.8	2.8	4.2	4.6	1.0
Crash Rate ^c	0.39	0.68	0.61	0.46	0.33	0.56	0.23
Significant ^d	No	No	No	No	No	No	No
<i>Type:</i>							
Angle	6	22	8	2	10	3	1
Rear-End	7	18	8	8	3	8	0
Head-On	0	2	0	0	0	0	0
Sideswipe	5	25	11	3	5	3	1
Fixed Object	0	2	3	0	3	0	1
Pedestrian	1	4	0	1	0	2	1
Bicyclist	4	2	1	0	0	4	0
<u>Unknown/Other</u>	<u>0</u>	<u>0</u>	<u>3</u>	<u>0</u>	<u>0</u>	<u>3</u>	<u>1</u>
Total	23	75	34	14	21	23	5
<i>Weather Conditions:</i>							
Clear	15	45	21	10	13	10	3
Cloudy/Rain	5	18	7	3	4	9	1
Snow/Ice	0	1	0	0	0	1	0
Fog	0	0	0	0	0	0	0
<u>Unknown/Other</u>	<u>3</u>	<u>11</u>	<u>6</u>	<u>1</u>	<u>4</u>	<u>3</u>	<u>1</u>
Total	23	75	34	14	21	23	5
<i>Lighting Conditions:</i>							
Daylight	18	42	23	8	13	18	4
Dawn/Dusk	1	2	1	0	0	1	0
Dark (lit)	4	30	10	5	7	3	0
Dark (unlit)	0	1	0	1	1	0	0
<u>Unknown/Other</u>	<u>0</u>	<u>0</u>	<u>0</u>	<u>0</u>	<u>0</u>	<u>1</u>	<u>1</u>
Total	23	75	34	14	21	23	5
<i>Pavement Conditions:</i>							
Dry	22	62	27	11	17	13	4
Wet	1	8	6	2	4	6	0
Snow/Ice	0	4	0	1	0	0	0
<u>Unknown/Other</u>	<u>0</u>	<u>1</u>	<u>1</u>	<u>0</u>	<u>0</u>	<u>4</u>	<u>1</u>
Total	23	75	34	14	21	23	5
<i>Severity:</i>							
Property Damage Only	15	53	25	10	16	8	1
Personal Injury	8	22	6	1	4	9	1
Fatality	0	0	0	0	0	0	0
<u>Unknown/Other</u>	<u>0</u>	<u>0</u>	<u>3</u>	<u>3</u>	<u>1</u>	<u>6</u>	<u>3</u>
Total	23	75	34	14	21	23	5

*See notes at end of table.

Table 2.d.1 (Continued)
VEHICLE CRASH DATA SUMMARY^a

	First Street at Upper Garage and Spring Street	First Street at Lower Garage West Entrance	First Street at Cambridgeside Place/Charles Street	Cambridgeside Place at Lower Garage South Exit	Cambridgeside Place at Lower Garage South Entrance	100 Cambridgeside Place
<i>Year:</i>						
2013	1	1	2	0	0	2
2014	0	1	2	0	0	4
2015	1	0	1	0	0	2
2016	1	0	1	0	0	16
2017	<u>0</u>	<u>1</u>	<u>1</u>	<u>0</u>	<u>0</u>	<u>7</u>
Total	3	3	7	0	0	31
Average ^b	0.6	0.6	1.4	0.0	0.0	6.2
Crash Rate ^c	0.17	0.21	0.29	--	--	--
Significant ^d	No	No	No	--	--	--
<i>Type:</i>						
Angle	2	1	0	0	0	2
Rear-End	0	0	2	0	0	1
Head-On	0	0	1	0	0	1
Sideswipe	1	1	1	0	0	11
Fixed Object	0	0	0	0	0	1
Pedestrian	0	0	1	0	0	2
Bicyclist	0	0	1	0	0	0
Unknown/Other	<u>0</u>	<u>1</u>	<u>1</u>	<u>0</u>	<u>0</u>	<u>13</u>
Total	3	3	7	0	0	31
<i>Weather Conditions:</i>						
Clear	2	1	6	0	0	16
Cloudy/Rain	1	5	1	0	0	8
Snow/Ice	0	0	0	0	0	0
Fog	0	0	0	0	0	0
Unknown/Other	<u>0</u>	<u>0</u>	<u>0</u>	<u>0</u>	<u>0</u>	<u>7</u>
Total	3	3	7	0	0	31
<i>Lighting Conditions:</i>						
Daylight	2	2	4	0	0	12
Dawn/Dusk	0	1	0	0	0	1
Dark (lit)	1	0	3	0	0	5
Dark (unlit)	0	0	0	0	0	0
Unknown/Other	<u>0</u>	<u>0</u>	<u>0</u>	<u>0</u>	<u>0</u>	<u>13</u>
Total	3	3	7	0	0	31
<i>Pavement Conditions:</i>						
Dry	2	2	7	0	0	21
Wet	0	1	0	0	0	0
Snow/Ice	0	0	0	0	0	0
Unknown/Other	<u>1</u>	<u>0</u>	<u>0</u>	<u>0</u>	<u>0</u>	<u>10</u>
Total	3	3	7	0	0	31
<i>Severity:</i>						
Property Damage Only	1	1	3	0	0	8
Personal Injury	1	0	0	0	0	2
Fatality	0	0	0	0	0	0
Unknown/Other	<u>1</u>	<u>2</u>	<u>4</u>	<u>0</u>	<u>0</u>	<u>21</u>
Total	3	3	7	0	0	31

*See notes at end of table.

Table 2.d.1 (Continued)
VEHICLE CRASH DATA SUMMARY^a

	Land Boulevard at Cambridgeside Place/ Hotel Driveway	Land Boulevard at Lower Garage East Entrance	Land Boulevard at Binney Street	Binney Street at First Street	Binney Street at Second Street	Binney Street at Third Street	Broadway at Third Street/ Main Street
<i>Year:</i>							
2013	8	0	2	6	3	4	6
2014	9	0	4	0	0	6	1
2015	5	0	4	2	2	1	1
2016	8	0	3	3	4	2	3
<u>2017</u>	<u>5</u>	<u>0</u>	<u>6</u>	<u>2</u>	<u>1</u>	<u>3</u>	<u>3</u>
Total	35	0	19	13	10	16	14
Average ^b	7.0	0.0	3.8	2.6	2.0	3.2	2.8
Crash Rate ^c	0.44	--	0.24	0.41	0.34	0.42	0.42
Significant ^d	No	--	No	No	No	No	No
<i>Type:</i>							
Angle	9	0	2	7	1	2	2
Rear-End	17	0	10	2	2	5	3
Head-On	0	0	0	0	0	2	0
Sideswipe	1	0	3	2	2	4	2
Fixed Object	1	0	0	1	1	2	0
Pedestrian	3	0	1	1	1	1	2
Bicyclist	1	0	2	0	1	0	4
<u>Unknown/Other</u>	<u>3</u>	<u>0</u>	<u>1</u>	<u>0</u>	<u>2</u>	<u>0</u>	<u>1</u>
Total	35	0	19	13	10	16	14
<i>Weather Conditions:</i>							
Clear	19	0	11	5	6	9	9
Cloudy/Rain	8	0	5	8	1	6	4
Snow/Ice	0	0	0	0	0	0	1
Fog	0	0	0	0	0	0	0
<u>Unknown/Other</u>	<u>8</u>	<u>0</u>	<u>3</u>	<u>0</u>	<u>3</u>	<u>1</u>	<u>0</u>
Total	35	0	19	13	10	16	14
<i>Lighting Conditions:</i>							
Daylight	20	0	12	11	6	12	13
Dawn/Dusk	2	0	0	1	1	0	0
Dark (lit)	11	0	7	1	2	3	1
Dark (unlit)	0	0	0	0	0	0	0
<u>Unknown/Other</u>	<u>2</u>	<u>0</u>	<u>0</u>	<u>0</u>	<u>1</u>	<u>1</u>	<u>0</u>
Total	35	0	19	13	10	16	14
<i>Pavement Conditions:</i>							
Dry	23	0	16	10	6	12	11
Wet	7	0	3	3	2	3	2
Snow/Ice	2	0	0	0	0	0	0
<u>Unknown/Other</u>	<u>3</u>	<u>0</u>	<u>0</u>	<u>0</u>	<u>2</u>	<u>1</u>	<u>1</u>
Total	35	0	19	13	10	16	14
<i>Severity:</i>							
Property Damage Only	22	0	12	6	6	9	6
Personal Injury	10	0	7	3	1	4	4
Fatality	0	0	0	0	0	0	0
<u>Unknown/Other</u>	<u>3</u>	<u>0</u>	<u>0</u>	<u>4</u>	<u>3</u>	<u>3</u>	<u>4</u>
Total	35	0	19	13	10	16	14

^aSource: MassDOT Crash Data.

^bAverage crashes over five-year period.

^cCrash Rate in crashes per million entering vehicles (mev).

^dCrash Rate noted as significant if rate exceeds 2018 MassDOT District 6 averages of 0.71 and 0.52 for signalized and unsignalized intersections, respectively.

Table 2.d.2
CRASH DATA SUMMARY: VEHICLE TO PEDESTRIAN^a

	O'Brien Highway at Museum Way	O'Brien Highway at Land Boulevard/Charlestown Avenue	Cambridge Street at First Street	Cambridge Street at Third Street	First Street at Thorndike Street	First Street at Cambridgeside Place and Charles Street	100 Cambridgeside Place
<i>Year:</i>							
2013	0	0	1	0	0	0	0
2014	1	1	0	1	1	1	0
2015	0	1	0	1	0	0	0
2016	0	1	0	0	0	0	2
<u>2017</u>	<u>0</u>	<u>1</u>	<u>0</u>	<u>0</u>	<u>0</u>	<u>0</u>	<u>0</u>
Total	1	4	1	2	1	1	2
Average ^a	0.2	0.8	0.2	0.4	0.2	0.2	0.4
<i>Time:</i>							
Weekday 7 to 9 AM	0	0	0	0	1	1	0
Weekday 4 to 6 PM	0	0	1	0	0	0	0
<u>Remainder of Day</u>	<u>1</u>	<u>4</u>	<u>0</u>	<u>2</u>	<u>0</u>	<u>0</u>	<u>2</u>
Total	1	4	1	2	1	1	2
<i>Pavement Conditions:</i>							
Dry	1	4	0	0	1	1	1
Wet	0	0	1	1	0	0	0
Snow	0	0	0	0	0	0	0
Icy	0	0	0	0	0	0	0
Other	0	0	0	0	0	0	0
<u>Unknown</u>	<u>0</u>	<u>0</u>	<u>0</u>	<u>1</u>	<u>0</u>	<u>0</u>	<u>1</u>
Total	1	4	1	2	1	1	2
<i>Day of Week:</i>							
Monday through Friday	1	2	1	1	1	1	1
<u>Saturday and Sunday</u>	<u>0</u>	<u>2</u>	<u>0</u>	<u>1</u>	<u>0</u>	<u>0</u>	<u>1</u>
Total	1	4	1	2	1	1	2
<i>Severity:</i>							
Property Damage Only	0	0	0	1	0	0	0
Personal Injury	1	4	1	1	1	0	2
Fatal Crashes	0	0	0	0	0	0	0
<u>Other/Unknown</u>	<u>0</u>	<u>0</u>	<u>0</u>	<u>0</u>	<u>0</u>	<u>1</u>	<u>0</u>
Total	1	4	1	2	1	1	2

*See notes at end of table.

Table 2.d.2 (Continued)
CRASH DATA SUMMARY: VEHICLE TO PEDESTRIAN^a

	Land Boulevard at Cambridgeside Place and Hotel Driveway	Land Boulevard at Binney Street	Binney Street at First Street	Binney Street at Second Street	Binney Street at Third Street	Broadway at Third Street/ Main Street
<i>Year:</i>						
2013	0	0	0	0	0	1
2014	1	0	0	0	0	0
2015	0	0	1	0	0	0
2016	2	0	0	1	0	0
2017	<u>0</u>	<u>1</u>	<u>0</u>	<u>0</u>	<u>1</u>	<u>1</u>
Total	3	1	1	1	1	2
Average ^b	0.6	0.2	0.2	0.2	0.2	0.4
<i>Time:</i>						
Weekday 7 to 9 AM	0	1	0	1	0	0
Weekday 4 to 6 PM	0	0	0	0	0	0
Remainder of Day	<u>3</u>	<u>0</u>	<u>1</u>	<u>0</u>	<u>1</u>	<u>2</u>
Total	3	1	1	1	1	2
<i>Pavement Conditions:</i>						
Dry	2	1	0	1	0	1
Wet	1	0	1	0	1	0
Snow	0	0	0	0	0	0
Icy	0	0	0	0	0	0
Other	0	0	0	0	0	1
Unknown	<u>0</u>	<u>0</u>	<u>0</u>	<u>0</u>	<u>0</u>	<u>0</u>
Total	3	1	1	1	1	2
<i>Day of Week:</i>						
Monday through Friday	2	1	1	1	1	1
Saturday and Sunday	<u>1</u>	<u>0</u>	<u>0</u>	<u>0</u>	<u>0</u>	<u>1</u>
Total	3	1	1	1	1	2
<i>Severity:</i>						
Property Damage Only	0	0	0	0	0	0
Personal Injury	3	1	0	1	1	2
Fatal Crashes	0	0	0	0	0	0
Other/Unknown	<u>0</u>	<u>0</u>	<u>1</u>	<u>0</u>	<u>0</u>	<u>0</u>
Total	3	1	1	1	1	2

^aSource: MassDOT Crash Data.

^bAverage crashes over five-year period.

Table 2.d.3
CRASH DATA SUMMARY: VEHICLE TO BICYCLIST^a

	O'Brien Highway at Museum Way	O'Brien Highway at Land Boulevard/ Charlestown Avenue	O'Brien Highway at Cambridge Street/ East Street	Cambridge Street at Third Street	First Street at Cambridgeside Place and Charles Street	Land Boulevard at Cambridgeside Place/ Hotel Driveway
<i>Year:</i>						
2013	1	0	1	2	0	0
2014	1	1	0	0	0	1
2015	0	1	0	1	0	0
2016	0	0	0	1	1	0
2017	<u>2</u>	<u>0</u>	<u>0</u>	<u>0</u>	<u>0</u>	<u>0</u>
Total	4	2	1	4	1	1
Average ^a	0.8	0.4	0.2	0.8	0.2	0.2
<i>Time:</i>						
Weekday 7 to 9 AM	1	0	0	1	1	0
Weekday 4 to 6 PM	1	1	0	0	0	1
Remainder of Day	<u>2</u>	<u>1</u>	<u>1</u>	<u>3</u>	<u>0</u>	<u>0</u>
Total	4	2	1	4	1	1
<i>Pavement Conditions:</i>						
Dry	4	2	1	3	1	1
Wet	0	0	0	1	0	0
Snow	0	0	0	0	0	0
Icy	0	0	0	0	0	0
Other	0	0	0	0	0	0
Unknown	<u>0</u>	<u>0</u>	<u>0</u>	<u>0</u>	<u>0</u>	<u>0</u>
Total	4	2	1	4	1	1
<i>Day of Week:</i>						
Monday through Friday	4	2	0	4	1	1
Saturday and Sunday	<u>0</u>	<u>0</u>	<u>1</u>	<u>0</u>	<u>0</u>	<u>0</u>
Total	4	2	1	4	1	1
<i>Severity:</i>						
Property Damage Only	1	0	0	0	1	1
Personal Injury	3	2	1	4	0	0
Fatal Crashes	0	0	0	0	0	0
Other/Unknown	<u>0</u>	<u>0</u>	<u>0</u>	<u>0</u>	<u>0</u>	<u>0</u>
Total	4	2	1	4	1	1

*See notes at end of table.

Table 2.d.3 (Continued)
CRASH DATA SUMMARY: VEHICLE TO BICYCLIST^a

	Land Boulevard at Binney Street	Binney Street at Second Street	Broadway at Third Street/Main Street
<i>Year:</i>			
2013	0	0	0
2014	0	0	0
2015	0	0	1
2016	2	1	2
<u>2017</u>	<u>0</u>	<u>0</u>	<u>1</u>
Total	2	1	4
Average ^a	0.4	0.2	0.8
<i>Time:</i>			
Weekday 7 to 9 AM	0	0	3
Weekday 4 to 6 PM	0	0	0
<u>Remainder of Day</u>	<u>2</u>	<u>1</u>	<u>1</u>
Total	2	1	4
<i>Pavement Conditions:</i>			
Dry	2	1	4
Wet	0	0	0
Snow	0	0	0
Icy	0	0	0
Other	0	0	0
<u>Unknown</u>	<u>0</u>	<u>0</u>	<u>0</u>
Total	2	1	4
<i>Day of Week:</i>			
Monday through Friday	1	1	4
<u>Saturday and Sunday</u>	<u>1</u>	<u>0</u>	<u>0</u>
Total	2	1	4
<i>Severity:</i>			
Property Damage Only	0	1	1
Personal Injury	2	0	1
Fatal Crashes	0	0	0
<u>Other/Unknown</u>	<u>0</u>	<u>0</u>	<u>2</u>
Total	2	1	4

^aSource: MassDOT and Cambridge Police Department Crash Data.

^bAverage crashes over five-year period.

The crash summary indicates the intersection of O'Brien Highway at Land Boulevard/ Charlestown Avenue has the highest crash total of the locations in the study area with an average of 15.0 crashes per year over the five-year study period. Approximately 25 percent of these crashes were rear-end type crashes, typically consistent with highly congested locations. The involvement of four pedestrians and two bicyclists was noted in the crash data at this location, which is under the jurisdiction of the MassDOT.

The intersection of Land Boulevard with Cambridgeside Place/the hotel driveway was noted to have an average of 7.0 crashes per year. The involvement of three pedestrians and one bicyclist was noted in the crash data at this location, which is under the jurisdiction of the Department of Conservation and Recreation (DCR). The intersection of First Street with Cambridgeside Place and Charles Street was noted to have an average of 1.4 crashes per year. The involvement of one pedestrian and one bicyclist was noted in the crash data at this location, which is under the jurisdiction of the City of Cambridge. The crash data indicates a total of 31 crashes at 100 Cambridgeside Place but zero crashes at the Lower Garage South Entrance or Exit Driveways.

It is likely that some of these crashes take place at the driveways; however, 35 percent of the crashes were noted as sideswipes which typically occur on a street setting as opposed to an intersection setting. The involvement of two pedestrians and zero bicyclists was noted in the crash data.

The study area includes 4 intersection with O'Brien Highway. These interactions experienced 21-75 crashes over the five-year review period averaging 4.2 to 15.0 crashes per year. Approximately 25 percent of these crashes were rear-end type crashes, typically consistent with highly congested locations. The involvement of five pedestrians and seven bicyclists was noted in the crash data for this corridor, which is under the jurisdiction of the MassDOT.

The study area includes 3 intersection with Land Boulevard (excluding O'Brien Highway at Land Boulevard which was already discussed). These interactions experienced 0-35 crashes over the five-year review period averaging 0.0 to 7.0 crashes per year. Approximately 50 percent of these crashes were rear-end type crashes, typically consistent with highly congested locations. The involvement of four pedestrians and three bicyclist was noted in the crash data for these intersections, which are under the jurisdiction of the DCR.

The study area includes 3 intersection with Binney Street (excluding Land Boulevard at Binney Street which was already discussed). These interactions experienced 10-16 crashes over the five-year review period averaging 2.0 to 3.2 crashes per year. Approximately 25 percent of these crashes were rear-end type crashes, typically consistent with highly congested locations. The involvement of three pedestrians and one bicyclist was noted in the crash data for these intersections, which is under the jurisdiction of the City of Cambridge.

No fatalities were reported over the five-year study period. As noted in Table 2.d.1 above, none of the intersections exceeded the MassDOT District 6 average crash rate for intersections, currently noted at 0.71 crashes per million entering vehicles (mev) for signalized intersections and 0.52 crashes per mev for unsignalized intersections. Accordingly, the crash rates at the studied intersections are not considered significant.

O'Brien Highway/Charles River Dam Road Modifications

While no fatalities were reported in the crash data for the period 2013 – 2017, a fatal crash did occur at the intersection of O'Brien Highway at Museum Way on November 9, 2018. The crash involved a truck striking a bicyclist while turning right from Museum Way onto O'Brien Highway. This crash led to a redesign of Charles River Dam Road roadway layout including the intersections of O'Brien Highway at Land Boulevard/Charleston Avenue and O'Brien Highway at Museum Way. New bicycle accommodations consisting of bike lanes with lane delineators on both sides of Charles River Dam Road and bike boxes for signal detection at the signalized intersections of Museum Way and Land Boulevard/Charlestown Avenue/O'Brien Highway were installed. High visibility ladder-type crosswalks were also added for pedestrians to cross Charles River Dam Road both north and south of Museum Way as well as Museum Way at the intersection. "Do Not Block Intersection" pavement markings and signs were also installed at the Museum Way intersection and the Museum of Science entrance and exit driveway intersections with Charles River Dam Road. Finally, an exclusive left-turn lane into Museum Way and one exclusive left-turn lane for Charles River Dam Road to Land Boulevard were also provided as part of that project.

2.7 EXISTING PUBLIC TRANSIT SYSTEM

The site is located near Lechmere Station on the MBTA Green Line subway system. The Green Line currently terminates at Lechmere Station, but construction is underway on an extension into Medford. Groundbreaking for the Green Line Extension (GLX) Project was held on June 25, 2018, with opening of the GLX scheduled for late 2021. Construction has also started on the new Lechmere Station which will be relocated to the north side of O'Brien Highway. It is expected that the new Lechmere Station will open with the GLX in 2021.

Construction on the GLX includes viaduct repairs on the Lechmere to North Station section. Consequently, the Green Line is scheduled to be replaced by bus service for that segment, starting on or around May 2020 and continuing for approximately 11 months.

The Green Line continues to North Station, where connections to the Orange Line and Commuter Rail routes can be made, and also to Park Street where connections to the Red Line are possible. The Lechmere station is also the terminating bus station for MBTA Bus Route 69, 80, 87 and 88. Table 2.e.1 summarizes the most recent Green Line headway and boarding data for the Lechmere station available from the MBTA.

**Table 2.e.1
MBTA GREEN LINE SERVICE SUMMARY**

Station	Rush Hour Headways (minutes) ^b	Daily Line Flow	Boarding Counts ^a			
			Weekday Morning Peak Hour		Weekday Evening Peak Hour	
			Boarding	Alighting	Boarding	Alighting
Lechmere	6-7	10,482	727	465	784	507

^aSource: MBTA composite of station passenger entry and ridership data, 2017 to 2019.

^bBased on MBTA schedule.

Table 2.e.2 summarizes the most recent Red Line headway and boarding data for the Kendall Square station available from the MBTA.

**Table 2.e.2
MBTA RED LINE SERVICE SUMMARY**

Station	Rush Hour Headways (minutes) ^b	Daily Line Flow	Boarding Counts ^a			
			Weekday Morning Peak Hour		Weekday Evening Peak Hour	
			Boarding	Alighting	Boarding	Alighting
Kendall/MIT	2-6	99,345	600	3,490	3,946	766

^aSource: MBTA composite of station passenger entry and ridership data, 2017 to 2019.

^bBased on MBTA schedule.

Table 2.e.3 summarizes the peak-hour headways and capacity information for the four bus routes servicing the Lechmere Station supplied by the MBTA.

**Table 2.e.3
MBTA BUS SERVICE SUMMARY^a**

Route No.	Route	Hours of Operation	Peak-Hour Headway (minutes)	Peak-Hour Peak-Direction Planning Capacity ^b	Daily Ridership	Estimated Daily Capacity
69	Harvard Square - Lechmere Station	5:25 AM to 1:11 AM	10-20	180-360	2,594	6,300
80	Arlington Center - Lechmere Station	5:00 AM to 1:26 AM	15-30	120-240	2,129	5,100
87	Arlington Center or Clarendon Hill - Lechmere Station	5:06 AM to 1:23 AM	16-30	120-225	3,491	5,580
88	Clarendon Hill - Lechmere Station	5:16 AM to 1:14 AM	8-25	144-450	3,914	6,780

^aSource: MBTA composite of station entry and ridership data, 2018.

^bPlanning capacity is 60 passengers per bus.

EZ Ride Shuttle Bus

In addition to the MBTA, the Charles River Transportation Management Association (CRTMA) provides the EZRide Shuttle Bus that circulates between Cambridgeport and North Station in Boston via the Kendall Square Red Line station. The EZRide Shuttle operates on weekdays between 6:20 AM and 10:54 AM during the morning time period on an 8 to 15-minute frequency with an 8-minute frequency target during the peak hours. During the midday time period, the EZRide Shuttle operates between 10:45 AM and 2:55 PM on a 15-minute frequency and operates between Pacific Street and Kendall Square only during this time. During the evening time period, the EZRide Shuttle operates between 2:55 PM and 7:58 PM on a 6 to 20-minute frequency with an 8-minute frequency target during the peak hour. During the weekday morning and weekday evening time periods, the bus stops closest to CambridgeSide at the intersections of First Street at Otis Street and First Street at Charles Street and CambridgeSide Place. During the midday time period, the EZRide does not travel near CambridgeSide and stays in the Kendall Square-Central Square area only. The EZRide Shuttle does not currently operate on weekends. The shuttle route and schedule is provided in the Appendix.

CambridgeSide is a member of the CRTMA and also subscribes to the EZRide Shuttle bus service. CambridgeSide employees can ride on the EZRide Shuttle for free; public access is permitted for a \$1.00 fee for adults and \$0.50 for children ages 5 to 11. Children younger than 5 ride for no charge.

Discussions with the CRTMA have indicated that while they are looking to update their system to better track users of the EZRide, they do not have an accurate estimate of ridership by member, including CambridgeSide tenants or visitors that use the EZRide shuttle. CambridgeSide users have a sticker applied to a driver's license or other ID card that gets shown to the bus operator; no daily record is documented. Information from the 2019 TDM Report indicated that approximately 4 percent of CambridgeSide tenants' employees responded that they take "Public Transportation and Drove/Carpooled/Took Shuttle" but the shuttle category is not clear as to whether the EZRide or other shuttle bus was utilized.

CambridgeSide Shuttle Bus

CambridgeSide operates the CambridgeSide shuttle bus providing free shuttle service from the Kendall Square T stop to CambridgeSide for an 11-hour period (9:00 AM to 8:00 PM) Monday through Saturday and for a 7-hour period (12:00 PM to 7:00 PM) on Sunday. The shuttle is operated by Bethany Transportation. The shuttle bus currently has only two stops: the Kendall Square T station and CambridgeSide. The shuttle bus runs in a continuous loop between these stops which typically results in the bus making three to four loops in an hour, or a headway of between 15 and 20 minutes. However, this is impacted by traffic congestion and more recently, construction in Kendall Square.

Data provided by CambridgeSide indicates that the shuttle bus has been experiencing decreasing ridership, as shown in Table 2.e.4.

**Table 2.e.4
CAMBRIDGESIDE SHUTTLE BUS
RIDERSHIP HISTORY**

<u>Year</u>	<u>Total Ridership^a</u>	<u>Change (percent)</u>
2015	219,357	--
2016	218,316	-0.47
2017	210,196	-3.72
2018	222,836	6.01
2019	190,788	-14.38

^aBased on TDM Monitoring reports from 2015 through 2019.

CambridgeSide has begun tracking hourly ridership for the shuttle bus usage as of June 15, 2019. Table 2.e.5 summarizes the hourly ridership for the period June 15, 2019 through March 20, 2020 when the shuttle bus was taken out of service due to the COVID-19 situation.

**Table 2.e.5
AVERAGE WEEKDAY SHUTTLE BUS RIDERSHIP
BY HOUR^a**

Hour Period ^b	Average Weekday Ridership	Percentage
9AM to 10AM	4	3%
10AM to 11AM	6	4%
11AM to 12PM	8	6%
12 PM to 1PM	11	8%
1PM to 2PM	14	10%
2PM to 3PM	14	10%
3PM to 4PM	17	12%
4PM to 5PM	18	13%
5PM to 6PM	18	13%
6PM to 7PM	16	12%
<u>7PM to 8PM</u>	<u>11</u>	8%
Total	137	100.0%

^aBased on shuttle bus logs for period from June 15, 2019 to March 20, 2020.

^bWeekday hours of operation are 9AM to 8PM.

2.8 EXISTING PARKING UTILIZATION

A review of parking utilization of the existing garages was conducted. CambridgeSide has agreements with the Royal Sonesta, Hotel Marlowe and the former Lotus building owners to provide a total of approximately 362 parking spaces on a long-term basis. These committed long-term non-tenant monthly parking spaces detailed in Section 9.2 below are separated out of any utilization counts as these spaces are not tracked by the automated count system in the garage. To be accurate, manual counts of the 362 long-term spaces would have to be conducted on the same days as the other counts, which are days that have already passed. To be conservative and to simplify calculations it was assumed all of these spaces are occupied and unavailable to other users.

CambridgeSide provides monthly parking to other users including mall employees and commuter parking for employers in the area that are included in the utilization counts. CambridgeSide has the ability to track these vehicles by type, specifically with regard to monthly or short-term transient users. A summary of the utilization data is provided in Table 2.f.1 for the Lower Garage and Table 2.f.2 for the Upper Garage, with charts documenting the use on Figure 2.f.1 and Figure 2.f.2, respectively.

**Table 2.f.1
LOWER GARAGE PARKING UTILIZATION SUMMARY^a**

Start Time	Weekday ^b			Utilization
	Transient	Monthly	Total	
Midnight-1am	20	38	58	3%
1am-2am	19	33	52	3%
2am-3am	18	25	43	3%
3am-4am	18	25	43	3%
4am-5am	18	25	43	3%
5am-6am	20	26	46	3%
6am-7am	29	52	81	5%
7am-8am	52	103	155	9%
8am-9am	76	217	293	17%
9am-10am	115	405	520	31%
10am-11am	171	575	746	44%
11am-Noon	238	633	871	51%
Noon-1pm	280	655	935	55%
1pm-2pm	338	661	999	59%
2pm-3pm	332	673	1005	59%
3pm-4pm	318	641	959	57%
4pm-5pm	292	583	875	52%
5pm-6pm	296	450	746	44%
6pm-7pm	286	287	573	34%
7pm-8pm	277	169	446	26%
8pm-9pm	259	128	387	23%
9pm-10pm	166	86	252	15%
10pm-11pm	88	44	132	8%
11pm-Midnight	65	24	89	5%
Max Percent Utilization				59%
Surplus Spaces at Peak			690	

^aBased on counts provided by CambridgeSide for Thursday August 23, 2018 with utilization based on 1,695 spaces available.

^bBased on 23 transient spaces and 49 monthly spaces occupied at beginning of count period.

**Table 2.f.2
UPPER GARAGE PARKING UTILIZATION SUMMARY^a**

Start Time	Weekday ^b			Utilization
	Transient	Monthly	Total	
Midnight-1am	1	3	4	1%
1am-2am	1	3	4	1%
2am-3am	1	3	4	1%
3am-4am	1	3	4	1%
4am-5am	1	3	4	1%
5am-6am	1	3	4	1%
6am-7am	3	4	7	1%
7am-8am	10	9	19	2%
8am-9am	18	27	45	6%
9am-10am	26	44	70	9%
10am-11am	44	66	110	14%
11am-Noon	68	71	139	17%
Noon-1pm	87	73	160	20%
1pm-2pm	101	81	182	23%
2pm-3pm	91	79	170	21%
3pm-4pm	94	75	169	21%
4pm-5pm	82	72	154	19%
5pm-6pm	85	56	141	18%
6pm-7pm	79	38	117	15%
7pm-8pm	67	28	95	12%
8pm-9pm	55	23	78	10%
9pm-10pm	22	16	38	5%
10pm-11pm	6	8	14	2%
11pm-Midnight	3	5	8	1%
Max Percent Utilization				23%
Surplus Spaces at Peak			613	

^aBased on counts provided by Cambridgeside for Thursday August 23, 2018 with utilization based on 795 spaces available.

^bBased on 2 transient spaces and 3 monthly spaces occupied at beginning of count period.

2.9 BICYCLE PARKING

Bicycle parking is also provided on and around the site. Short-term bicycle parking for 100 bicycles have been provided by CambridgeSide. This includes racks located in the Canal Park area, along Cambridgeside Place, and the CambridgeSide-sponsored BLUEbikes station located on Cambridgeside Place that provides 15 bikes for general public use. Within the garage, 46 long-term (weather-protected) bicycle spaces are provided on the first level of the Lower Garage.

Anecdotal information indicates that the short-term bicycle spaces get used frequently; however the long-term spaces in the garage are seldom used. Other locations that get used for short-term bicycle parking include sign posts on Cambridgeside Place, and railings along Canal Park. Short-term bicycle racks are the DERO post-and-ring bike hitch, model number BH-FT-EPX-X, powder coated in black or silver which accommodate two bikes each. Long-term racks are the wave-rack type, painted white or black.

2.10 EXISTING PARKING OPERATIONS AND CURRENT RATE SCHEDULE

LAZ Parking currently manages the operations in the parking garages. The current rate schedule is shown below in Table 2.f.3 and may be subject to change.

**Table 2.f.3
CAMBRIDGESIDE CURRENT PARKING RATES^a**

Time Period	Cost
Short-Term Rates	
Up to 30 minutes	\$3
30 minutes to 1 hour	\$4
1-2 hours	\$5
2-3 hours	\$8
3-4 hours	\$12
4-5 hours	\$18
5-6 hours	\$25
6-12 hours	\$30
Monthly Charges	
Tenants	\$125
Non-Tenants	\$275
HOV	\$185

^aSource: CambridgeSide.

2.11 EXISTING LOADING AND TRASH OPERATIONS

The site is presently serviced through two loading areas, accessed from Land Boulevard and First Street. There are trash dumpsters located in each loading area that are emptied on Mondays and Fridays, typically prior to 5AM. There are separate cardboard dumpsters in each loading area that are emptied every 5 days. Recycling is also removed from the site on a weekly basis. There are no time restrictions on deliveries to the mall; however, deliveries to any stores that are made through the common area must be made before or after mall hours.

2.12 EAST CAMBRIDGE DEVELOPMENTS

Information was requested from the Cambridge Community Development Department (CDD) regarding East Cambridge-area office, R&D, and residential developments that are located in the vicinity of the Project in order to obtain mode split data for sites comparable to the Project. These sites are shown on Figure 2.g.1. Additional information on these sites is provided in the following sections of this TIS.

3.0 PROJECT TRAFFIC

3.1 TRIP GENERATION

The Project involves the retention of a portion of the core retail business with the redevelopment of anchor buildings to create a mixed-use development providing Office/Research & Development (R&D), Retail, and Residential uses on the Site. Trip generation rates were empirically-derived from monitoring reports for Office/R&D and Residential developments in the East Cambridge area. These rates were developed in coordination with the Cambridge Traffic, Parking, & Transportation (TP&T) Department, due to recognition of observed driveway counts and resulting trip-generation rates that are considerably lower in Cambridge than those suggested by the Institute of Transportation Engineers (ITE) *Trip Generation Manual*¹. The trip generation calculated for the Third Floor Re-Tenancing Project was approved as part of the Third Floor TIS. These trips are incorporated with minor revisions to trip distribution and are utilized in the Modified Baseline Condition, described in Section 3.3 of this report.

Empirical Trip Generation

Parking and Transportation Demand Management (PTDM) studies from 2017 through 2019 for two office buildings and one R&D building in the vicinity of the Project were used to determine an empirical trip generation rate for office/R&D uses in this area of Cambridge. In addition, similar data from three residential sites was used to develop an empirical trip generation rate for residential uses in the project vicinity. These rates were reviewed with the City of Cambridge TP&T and CDD staff, who provided additional data for the residential trip rates. The resulting empirical rates were approved by the TP&T Department in their Scoping Letter of March 30, 2020, which also contained combined mode-split data for three office/R&D and five residential developments obtained from PTDM reports for these sites. These mode split values are provided in Table 3.a.1. Table 3.a.2 provides the empirically-derived trip rates for the office/R&D and Residential developments. Spreadsheets documenting these calculations are provided in the Appendix.

¹ *Trip Generation Manual, 10th Edition*; Institute of Transportation Engineers; Washington, D.C.; 2017.

**Table 3.a.1
EAST CAMBRIDGE-AREA MODE SPLITS**

Characteristics/Mode Split	Office/R&D ^a	Residential ^b
<u>Mode Split Characteristics</u>		
Single Occupancy Vehicle (SOV)	39	27
High Occupancy Vehicle (HOV)	3	9
Transit	37	29
Pedestrian	5	29
Bicycle	6	6
Work at Home	9	0
<u>Other</u>	<u>1</u>	<u>0</u>
TOTAL	100	100

^aBased on 2017-2019 PTDM reports from 150 Second Street, One Rogers Street, and Two Canal Street buildings.

^bBased on 2017-2019 PTDM reports from Avalon Bay North Point, North Point S&T, Twenty20, 303 Third Street, and One First Street.

**Table 3.a.2
EMPIRICAL TRIP GENERATION RATES**

Time Period	Empirical ^a Office/R&D Vehicle Trip Rates	Empirical ^b Residential Vehicle Trip Rates
<i>Weekday:</i>		
Entering	1.45	0.45
<u>Exiting</u>	<u>1.45</u>	<u>0.45</u>
Total	2.90	0.90
<i>Weekday Morning Peak Hour:</i>		
Entering	0.36	0.03
<u>Exiting</u>	<u>0.02</u>	<u>0.07</u>
Total	0.38	0.10
<i>Weekday Evening Peak Hour:</i>		
Entering	0.04	0.06
<u>Exiting</u>	<u>0.32</u>	<u>0.04</u>
Total	0.36	0.10

^aBased on 2017-2019 PTDM reports from 150 Second Street, One Rogers Street, and Two Canal Street.

^bBased on 2017-2019 PTDM reports from Avalon Bay North Point, North Point S&T, Twenty20, and 303 Third Street.

Person Vehicle Trip Generation

Trip rates from Table 3.a.2 were used to calculate vehicle trips for each land use and the mode splits from Table 3.a.1 were used to calculate a Vehicle Occupancy Ratio (VOR) as suggested by TP&T staff, which was then used to develop person trip generation. The person trips were then applied to the mode split data to calculate the appropriate share for each transportation mode. The vehicle trips associated with the proposed land uses are shown in Table 3.a.3. Spreadsheets documenting these calculations are provided in the Appendix.

**Table 3.a.3
PROJECT TRIP GENERATION BY MODE**

Size	Use	MODE SPLIT PERCENTAGES							TOTAL	
		VOR	SOV	HOV	TRANSIT	PED	BIKE	OTHER		
200	Apartment Units	1.14	27%	9%	29%	29%	6%	0%	100%	
875	ksf of Office/R&D	1.037	39%	3%	37%	5%	6%	10%	100%	

Daily	Trip Rate	Total Vehicle Trips	Person Vehicle Trips	Total Person Trips	SOV Person Trips	HOV Person Trips	Transit Person Trips	Ped Person Trips	Bike Person Trips	Other Person Trips
<i>Residential</i>										
Enter	0.45	90	103	286	77	26	83	83	17	0
Exit	0.45	90	103	286	77	26	83	83	17	0
Total	0.90	180	206	572	154	51	166	166	34	0
<i>Office/R&D</i>										
Enter	1.45	1269	1316	3133	1222	94	1159	157	188	313
Exit	1.45	1269	1316	3133	1222	94	1159	157	188	313
Total	2.90	2538	2632	6266	2444	188	2,318	313	376	627
<i>Site Totals</i>										
Enter		1359	1419	3419	1299	120	1242	240	205	313
Exit		1359	1419	3419	1299	120	1242	240	205	313
Total		2718	2838	6838	2598	240	2484	480	410	626
Weekday Morning										
	Trip Rate	Total Vehicle Trips	Person Vehicle Trips	Total Person Trips	SOV Person Trips	HOV Person Trips	Transit Person Trips	Ped Person Trips	Bike Person Trips	Other Person Trips
<i>Residential</i>										
Enter	0.03	6	7	19	5	2	6	6	1	0
Exit	0.07	14	16	44	12	4	13	13	3	0
Total	0.10	20	23	63	17	6	18	18	4	0
<i>Office/R&D</i>										
Enter	0.36	315	327	778	303	23	288	39	47	78
Exit	0.02	18	19	45	18	1	17	2	3	5
Total	0.38	333	346	823	321	25	305	41	49	82
<i>Site Totals</i>										
Enter		321	334	797	309	25	293	44	48	78
Exit		32	35	89	30	5	29	15	5	5
Total		353	369	886	339	30	322	59	53	83
Weekday Evening										
	Trip Rate	Total Vehicle Trips	Person Vehicle Trips	Total Person Trips	SOV Person Trips	HOV Person Trips	Transit Person Trips	Ped Person Trips	Bike Person Trips	Other Person Trips
<i>Residential</i>										
Enter	0.06	12	14	39	11	4	11	11	2	0
Exit	0.04	8	9	25	7	2	7	7	2	0
Total	0.10	20	23	64	17	6	19	19	4	0
<i>Office/R&D</i>										
Enter	0.04	35	36	86	34	2	32	4	5	9
Exit	0.32	280	290	690	269	21	255	35	41	69
Total	0.36	315	326	776	303	23	288	39	47	78
<i>Site Totals</i>										
Enter		47	50	125	45	6	43	15	7	9
Exit		288	299	715	276	23	262	42	43	69
Total		335	349	840	321	29	305	57	50	78

It is important to note that the 875,000 sf of Office/R&D is over and above the existing 140,000 sf on the third floor of the core mall.

Trip Credits

Existing Uses to be Removed - Retail

Since a portion of the retail space at CambridgeSide will be removed, estimates of existing retail vehicle trips were developed so that these trips may be removed from the street network. The following paragraphs describe this process.

The CambridgeSide parking garages have a counter system that can provide counts of vehicles entering and exiting the Upper or Lower Garage on regular intervals. The system is able to distinguish between vehicles that park monthly and vehicles that park on a short-term or transient basis. In order to utilize this data to develop estimates of retail trips, the following steps were performed, using garage data provided by CambridgeSide:

- As requested by TP&T staff, updated counts of the garage activity were utilized for this analysis, which indicated a reduction in retail activity from the counts utilized in the Third Floor TIS in November 2018. Counts from March 6, 2019 (the same day of supplemental intersection counts for the study area) were chosen to represent retail traffic activity for this analysis.
- Monthly parkers were removed from the total garage counts; this resulted in isolation of the transient parked vehicles.
- The counts of transient parked vehicles were then limited to hours that the retail stores are open (10:00 AM to 9:00 PM) to derive the count of vehicles likely associated with retail activity.
- The counts of these remaining vehicles were further refined to exclude the counts of vehicles parked longer than eight hours, which represent vehicles parked by employees or visitors parking for the day.
- The resulting counts were divided by the original entering volumes to derive a percentage that represented the amount of retail transient vehicles occurring on a weekday basis. The process resulted in adjustments that indicated 63.4 percent of the weekday traffic was related to retail activity.
- These percentages were then applied to the observed garage volumes during the weekday morning and weekday evening peak hour time periods.

Once the retail traffic was separated from the total count volume, traffic volumes associated with the then-occupied total of 401,100 sf of retail space were reduced by 20 percent to represent the proposed new total of approximately 320,000 sf of remaining retail space associated with the Project. Although tenants of CambridgeSide generally open after 10:00 AM, both a Dunkin' and Starbucks open at 5:30 AM and 6:30 AM respectively on weekdays which account for the weekday morning peak hour trips. The estimated trips resulting from this empirically-based trip generation method are shown in Table 3.a.4.

**Table 3.a.4
EMPIRICAL TARGETED RETAIL TRIP GENERATION**

Time Period/ Directional Distribution	Counted Transient Vehicle Trips ^a	Total Retail Vehicle Trips ^b	Targeted Core Retail Vehicle Trips ^c
<i>Weekday:</i>			
Entering	1,362	864	175
<u>Exiting</u>	<u>1,326</u>	<u>841</u>	<u>170</u>
Total	2,688	1,705	345
<i>Weekday Morning Peak Hour:</i>			
Entering	59	37	7
<u>Exiting</u>	<u>5</u>	<u>3</u>	<u>1</u>
Total	64	40	8
<i>Weekday Evening Peak Hour:</i>			
Entering	110	70	14
<u>Exiting</u>	<u>142</u>	<u>90</u>	<u>18</u>
Total	252	160	32

^aBased on CambridgeSide garage counts provided by Cambridgeside during March 6, 2019 count period.

^bBased on information provided by Cambridgeside. Net result of 63.4 percent reductions applied to counted transient vehicle trips to account for retail activity.

^cTargeted for removal to construct the Project. Based on 20 percent of total retail trips to result in trips associated with 320 ksf of remaining retail space.

The number of “Counted Transient Retail Vehicle Trips” was determined based on the garage counts which indicate approximately 64 weekday morning peak hour vehicle trips. Although the majority of CambridgeSide opens after 10 AM, the Dunkin’ and Starbucks establishments open earlier. Dunkin’ opens at 5:30 AM Monday to Sunday while the Starbucks opens at 6:30 AM Monday to Friday, 7:30 AM on Saturday, and 8:30 AM on Sunday. Based on the 2018 PTDM report for CambridgeSide, Dunkin’ is listed at 439 square feet (sf) and Starbuck is listed at 1,499 sf. The PTDM report also states that Dunkin’ has 16 employees and Starbucks has 13 employees. Using the Institute of Transportation Engineers (ITE) Land Use Code (LUC) 936 – Coffee/Donut Shop without Drive-Through Window and 1,938 sf the anticipated weekday morning peak hour trips is 196 vehicles (100 entering and 96 exiting). Assuming 30 percent of the trips are made by automobiles, which is reasonable based on the fact the PTDM report states the single occupancy vehicle mode split to be 28 percent, the vehicle trip generation would be around 59 weekday morning peak hour trips. Assuming 2 employees arrive during the weekday morning peak hour for each establishment then the number increases to 63. Base on this reasoning it is reasonable to assume that 64 weekday morning vehicle retail trips would occur.

At the time of the traffic counts, the site was generating a level of activity from employees and customers. The removal of the floor area justifies the removal of these trips, and in lieu of a different procedure, could be calculated using ITE trip rates for retail. To provide a conservative scenario, the process identified above uses counted retail trips at the site, which are considerably less intensive than ITE trip equations would indicate, and which correlates with the fact that foot traffic at CambridgeSide has steadily declined over the past decade.

Retail traffic has steadily declined at CambridgeSide over the previous several years. A review of transient ticket/trips for the period 2016 to 2019 is shown below. Retail trips were calculated using the same methodology as identified above.

**Table 3.a.5
CAMBRIDGESIDE TRANSIENT TICKET HISTORY**

Year	Annual Transient Tickets ^a (vehicles/year)	Annual Retail Tickets (vehicles/year)	Change in Annual Retail Tickets (percent)
2016	933,611	659,393	--
2017	841,798	536,580	-18.63
2018	733,288	565,312	5.35
2019	569,177	428,981	-24.12
		Decrease, 2016 - 2019	-34.94

^aBased on data provided by CambridgeSide.

As shown, retail vehicle traffic has decreased by nearly 35 percent since 2016. Were retail activity in 2019 similar to what it was over the past several years, a similar removal of retail space as that proposed would result in the loss of a greater amount of vehicle trips than is shown to be the case using the latest data. However, using this approach provides a conservative analysis condition when reviewing project impacts.

Existing Uses to be Removed: Non-Tenant Monthly Parkers

The Project involves the redevelopment of the Upper Garage into a mixed-use building. The Project will also include a phased reduction, as necessary, of the non-tenant monthly parkers (excluding the committed long-term monthly parking spaces detailed in Section 9.2 below) that predominantly park in the Lower Garage in order to accommodate parking for the Project. The proposed improvements to the Green Line and Red Line along with the expansion of micro-mobility services are expected to reduce the overall demand for such monthly parking at the garage.

The Total Monthly Parkers include employees of tenant companies, non-tenant employees of nearby companies, and parking temporarily displaced by construction and/or temporary contractor parking. The Non-Tenant Monthly Parkers are comprised only of non-tenant employees of nearby companies. The Remaining Monthly Parkers are therefore comprised of the employees of tenant companies and parking temporarily displaced by construction and/or temporary contractor parking.

The practice of providing parking for non-tenant monthly parkers, other than committed long-term monthly parking spaces detailed in Section 9.2 below, will be phased out as the Project progresses, allowing for the Lower Garage to support the site’s parking demand. Based on CambridgeSide garage parking data from March, October, and December 2019, reductions in the number of non-tenant monthly parkers could make available up to 630 parking spaces for the Project and reduce the volume of traffic accessing the remaining Lower Garage. The data was obtained by averaging CambridgeSide garage counts conducted in March, October, and December 2019. As shown in Table 3.a.6 below, the Non-Tenant Monthly Parker Vehicle Trips (B) are subtracted from the Total Monthly Parker Vehicle Trips (A) to calculate the Remaining Monthly Parker Vehicle Trips (C).

**Table 3.a.6
MONTHLY PARKER TRIP GENERATION^a**

Time Period/ Directional Distribution	Total Monthly Parker Vehicle Trips (A)	Non-Tenant Monthly Parker Vehicle Trips (B)	Remaining Monthly Parker Vehicle Trips (C=A-B)
<i>Weekday:</i>			
Entering	1,066	630	436
<u>Exiting</u>	<u>1,092</u>	<u>630</u>	<u>462</u>
Total	2,158	1,260	898
<i>Weekday Morning Peak Hour:</i>			
Entering	246	212	34
<u>Exiting</u>	<u>4</u>	<u>1</u>	<u>3</u>
Total	250	213	37
<i>Weekday Evening Peak Hour:</i>			
Entering	10	3	7
<u>Exiting</u>	<u>270</u>	<u>208</u>	<u>62</u>
Total	280	211	69

^aBased on CambridgeSide garage counts and average of days in March, October, and December 2019.

These totals are based on the range of counts reviewed for non-tenant monthly parkers (excluding the committed long-term monthly parking spaces detailed in Section 9.2) and as with the Transient and Retail count data initially reviewed for the Third Floor TIS, these totals have also decreased with the latest peak utilization data averaging approximately 630 parking spaces utilized between the three time periods of March, October, and December in 2019. Therefore, it is conservative to only remove the trips associated with a minimum of 630 parking spaces over a daily basis. The count data for the peak hours were also reviewed and averaged, which resulted in traffic volumes similar to those previously estimated in the Third Floor TIS.

As with the removal of a portion of the current retail trips to the site, the removal of the non-tenant monthly parker vehicle trips, other than those attributed to the committed long-term monthly parking spaces detailed in Section 9.2 below, is reasonable since the practice of outside entities using these spaces will be gradually reduced over time. The total number of spaces to be made available during the day is based on previously reviewed and analyzed count data and not on estimates from outside sources such as ITE or ULI. It is anticipated that some portion of the trips generated by these non-tenant monthly parkers will be re-distributed to nearby parking garages, though it is anticipated that the majority of these users will instead rely on the improved public transit services in the future and other TDM measures. The projected future vehicle and transit counts in this TIS account for this re-distribution of non-tenant monthly parkers to be phased out of the site over the course of the Project buildout period.

The garage will continue to be available for use by East Cambridge residents during snow emergencies.

Total Project Net New Trip Generation

The combination of the removal of a portion of the retail space and associated vehicle trips and a phased reduction of the non-tenant monthly parking practice and associated vehicle trips has a large

effect on total site vehicle trip generation. The removal of the targeted retail trips and a portion of the non-tenant monthly parkers' trips from the Total Proposed Uses Vehicle Trips results in the Project Net New Vehicle Trips which are shown in Table 3.a.7.

Table 3.a.7
TOTAL PROJECT NET NEW VEHICLE TRIP GENERATION

Time Period/ Directional Distribution	Total Additional Vehicle Trips	Targeted Core Retail Vehicle Trips	Non-Tenant Monthly Parker Vehicle Trips	Project Net New Vehicle Trips
<i>Weekday:</i>				
Entering	1,359	-174	-630	555
<u>Exiting</u>	<u>1,359</u>	<u>-170</u>	<u>-630</u>	<u>559</u>
Total	2,718	-344	-1,260	1,114
<i>Weekday Morning Peak Hour:</i>				
Entering	321	-7	-212	102
<u>Exiting</u>	<u>32</u>	<u>-1</u>	<u>-1</u>	<u>30</u>
Total	353	-8	-213	132
<i>Weekday Evening Peak Hour:</i>				
Entering	47	-14	-3	30
<u>Exiting</u>	<u>288</u>	<u>-18</u>	<u>-208</u>	<u>62</u>
Total	335	-32	-211	92

3.2 TRIP DISTRIBUTION

Project trips were distributed using a blend of trip distribution information from other area traffic studies and the Third Floor TIS, the latter of which was used as a starting point and then adjusted based on traffic patterns from the larger study area as well as other sources. For the Office and R&D components, these include the office components of the First Street Assemblage project, the Courthouse project, the K2C2 Office distributions and the 2010 PTDM Employee distribution study. For the Residential component, distributions from the residential components of the First Street Assemblage project and the Kendall Square Urban Infill Project (Ames Street Residences) were used, and locations of the top 25 employers in Cambridge were also considered. Retail trips to be removed from the network were distributed based on existing traffic patterns and the retail distribution from the First Street Assemblage project, along with employee and customer zipcode data from the 2017 and 2019 CambridgeSide TDM Monitoring Report. Trips associated with the Upper Garage entrance movements were reassigned to the Lower Garage entrance on First Street. Trips associated with the Upper Garage and Lower Garage exit movements were reassigned to the Lower Garage exit on Cambridgeside Place. The Office/R&D trip distribution is shown on Figure 3.b.1. The Residential trip distribution is shown on Figure 3.b.2. The Retail trip distribution is shown on Figure 3.b.3. Table 3.b.1 summarizes the trip distribution for the Office/R&D, Residential, and Retail components of the development.

**Table 3.b.1
TRIP-DISTRIBUTION SUMMARY**

Use	Route	Direction	Percentage From Direction to Site	Percentage To Direction from Site
Office/R&D	O'Brien Highway	West	20	20
	O'Brien Highway	East	4	4
	Land Boulevard	North	20	20
	Land Boulevard	South	23	33
	Binney Street	West	7	7
	Broadway	East	18	0
	First Street	South	0	8
	Charles Street	West	4	0
	Spring Street	West	0	4
	Cambridge Street	West	<u>4</u>	<u>4</u>
	TOTAL		100	100
Residential	O'Brien Highway	West	4	4
	O'Brien Highway	East	8	8
	Land Boulevard	North	4	4
	Land Boulevard	South	40	40
	Binney Street	West	16	16
	Broadway	West	16	16
	Cambridge Street	West	<u>12</u>	<u>12</u>
	TOTAL		100	100
Retail	O'Brien Highway	East	12	12
	Land Boulevard	North	12	12
	Land Boulevard	South	15	15
	Binney Street	West	18	18
	Broadway	West	10	10
	Cambridge Street	West	<u>33</u>	<u>33</u>
	TOTAL		100	100

3.3 2020 MODIFIED BASELINE CONDITION WITH THIRD-FLOOR RE-TENANTING TO OFFICE USE

A 2020 Modified Baseline Condition was developed to account for the third-floor re-tenanting to office use. The 2020 Existing traffic volume networks were adjusted by removing the third-floor retail trips as shown on Figure 3.c.1 and 3.c.2 and adding the new office trips as shown on Figure 3.c.3 and 3.c.4. The resulting 2020 Modified Baseline traffic volumes are shown on Figure 3.c.5 and Figure 3.c.6 for the weekday morning and weekday evening peak hours respectively. Table 3.c.1 summarizes the weekday morning and weekday evening peak hour traffic volumes associated with the third-floor re-tenanting.

**Table 3.c.1
THIRD FLOOR NET NEW VEHICLE TRIP GENERATION SUMMARY^a**

Time Period/ Directional Distribution	Third-Floor Office Trips Added	Third-Floor Retail Trips Removed	Third-Floor Net New Vehicle Trips
<i>Weekday Morning Peak Hour:</i>			
Entering	61	-11	50
<u>Exiting</u>	<u>10</u>	<u>-1</u>	<u>9</u>
Total	71	12	59
<i>Weekday Evening Peak Hour:</i>			
Entering	11	-24	-13
<u>Exiting</u>	<u>59</u>	<u>-23</u>	<u>36</u>
Total	70	-47	23

^aFrom Third-Floor Office Re-Tenancing of CambridgeSide TIS approved by Planning Board in 2019.

These trips were identified in the Third Floor TIS which were used unchanged for this analysis condition. Minor changes to trip distribution from the Third Floor TIS were incorporated into this condition due to the expansion of the study area and review of traffic patterns at intersections and roadways further from the site.

3.4 VEHICLE TRIP RE-DISTRIBUTION

To determine the net new Project generated vehicle trip increase on the study area roadways, several redistribution steps were required, including the relocation of the Upper Garage vehicle trips to the Lower Garage driveways. The relocated Upper Garage trips are shown on Figure 3.d.1 and Figure 3.d.2 for the weekday morning and weekday evening peak hours, respectively.

The next step was the redistribution of the non-tenant monthly parker trips expected to be removed from the site driveways. It is important to note that the development of the Project is expected to occur over a multi-year period. This allows a phased reduction of non-tenant monthly parking practices to occur, leaving enough notice for these motorists to find alternative parking arrangements or preferably, shift from a driving mode to a more sustainable mode such as transit or bicycling. Given the expansion of the Green Line and Red Line MBTA services and the increasing availability of micro-mobility devices, this is a reasonable outcome over a 10-year timeframe.

However, there may be some motorists that will choose to continue to drive to the area, particularly those with parking facilities available on-site or nearby. Some may also choose to use the City First Street Garage, which provides over 1,100 parking spaces. A parking study prepared in 2019 for the City by McMahon Associates, Inc. and Kleinfelder determined that “Analysis of the existing off-street commercial parking supply in the study area shows that supply is significantly higher than demand, even if parking capacity at the CambridgeSide mall is reduced in the future due to any redevelopment of portions of that site.”² Several of the non-tenant companies along the upper end of First Street are likely to use that garage. Based on PTDM reports for sites in the area,

² *First Street Area Parking Planning Study*; Kleinfelder and McMahon Associates; Boston, MA; June 14, 2019.

capacity exists in these site garages located north and south of the Project on First Street; in some case more than enough to satisfy the number of parking spaces leased at CambridgeSide for these users.

In addition to the potential use of the existing parking garages in the area, both public and private, an expansion of TDM for these non-tenant parkers was assumed to occur. The elimination of parking coupled with expansion of transit and the growth of TDM measures for companies in Cambridge and Boston may result in complete elimination of these trips from the street network. It is also anticipated that additional work-from-home opportunities will be created following the COVID-19 situation, greatly reducing the need for parking facilities.

All non-tenant monthly parking trips were removed from the driveways to the Lower Garage. A total of 58 percent of the trips would be expected to use transit facilities as a result of TDM measures, with the other 42 percent redistributed from the Lower Garage driveways to alternative parking facilities. However, to be conservative, 100 percent of these trips were assumed to be redistributed from the Lower Garage driveways to alternative parking facilities. The 58 percent trip total is reflected in the transit analyses provided in Section 10 of this report. This is a very conservative condition as 58 percent of the trips are being counted as both vehicle and transit trips. Table 3.d.1 indicates the redistribution of trips by non-tenants currently parking at CambridgeSide.

**Table 3.d.1
NON-TENANT TRIP RE-DISTRIBUTION SUMMARY**

Time Period/ Directional Distribution	Non-Tenant Monthly Parker Vehicle Trips ^a	Retained Vehicle Trips ^b	TDM/Transit Vehicle Trips ^c
<i>Weekday Morning Peak Hour:</i>			
Entering	212	89	123
<u>Exiting</u>	<u>1</u>	<u>0</u>	<u>1</u>
Total	213	89	124
<i>Weekday Evening Peak Hour:</i>			
Entering	3	1	2
<u>Exiting</u>	<u>208</u>	<u>87</u>	<u>121</u>
Total	211	88	123

^aFrom Table 3.a.7.

^bAssumed to be 42 percent of Non-Tenant Monthly Parkers, based on proximity to available parking facilities in area.

^cAssumed to be 58 percent of Non-Tenant Monthly Parkers, based on increasing TDM success and availability of expanded transit services.

Of the retained vehicle trips, several destinations are anticipated to be utilized. These locations are shown on Figure 3.d.3. The trips associated with the relocation of these users are shown on the Non-Tenant Monthly Parker Removal networks depicted on Figure 3.d.4a and Figure 3.d.4b for the same time periods. (These trips were redistributed using the Office/R&D trip distribution.)

Trips associated with the Targeted Core Retail Trip Removal are shown on Figure 3.d.5 for the weekday morning peak hour and Figure 3.d.6 for the weekday evening peak hour. The proposed office/R&D trips for the same time periods are shown on Figure 3.d.7 and Figure 3.d.8. The proposed residential trips for the same time periods are shown on Figure 3.d.9 and Figure 3.d.10. The Net New vehicle trips accounting for the respective uses to be eliminated from the garage driveways and the proposed land uses are shown on Figure 3.d.11 and Figure 3.d.12.

3.5 PROJECT SERVICE AND LOADING

The two existing loading areas are expected to be modified to accommodate the expansion in deliveries to and from the proposed uses. Figure 3.e.1 depicts the proposed changes to the 20 CS (Macy's) loading dock on Land Boulevard and Figure 3.e.2 depicts the proposed changes to the First Street loading facility. Both proposed loading area layouts depict the outline of the existing loading areas shown, indicating minor changes to the loading area layouts. Daily office truck trips are typically limited to package pickup and delivery carried out using single-unit or delivery trucks. These trips are expected to total less than ten vehicles per day (less than 20 daily truck trips), accounting for the various courier and delivery services expected. Trash is expected to be accommodated within the existing pickup schedule of twice weekly for CambridgeSide.

4.0 BACKGROUND TRAFFIC

Traffic volumes in the study area were projected to the year 2025, which reflects a five-year planning horizon consistent with City traffic study guidelines and the traffic study scope issued by the City TP&T Department. Traffic volume conditions would include increases due to development projects approved or under construction and not yet occupied and increases to general background traffic levels, assumed to increase at 0.5 percent per year.

As indicated in the Scoping Letter, the following projects were identified for inclusion in the Future 2025 condition:

- *First Street Mixed-Use project*
- *Cambridge Courthouse Redevelopment (40 Thorndike Street)*
- *Cambridge Crossing*
- *Alexandria Binney Street development*
- *249 Third Street*
- *MIT Kendall Square development*
- *Kendall Square Urban Renewal Plan (KSURP) Infill Development Concept Plan*
- *Foundry Building*

4.1 FIRST STREET EXTENSION AND LECHMERE STATION RELOCATION

As part of the Cambridge Crossing development project, First Street in Cambridge will be extended from its current terminus with Cambridge Street northerly to O'Brien Highway. O'Brien Highway will be intersected by First Street from the south and North First Street from the north to form a four-way signalized intersection. The current intersection of First Street at Cambridge Street will become a four-way signalized intersection under traffic signal control. Extending First Street will improve access to the Cambridge Crossing Development. Currently, East Street provides the only access to the Cambridge Crossing Development. The extension of First Street will be constructed in conjunction with the development of Parcel Q and Parcel R for Cambridge Crossing which are the parcels to the east and west of North First Street and the new Lechmere Station. Projections for re-routed traffic volumes due to these roadway changes were developed using intersection and roadway geometries and travel lane assignments as presented in the Final Design Phase 2B package submitted on October 2, 2018 for the O'Brien Highway (Route 28 Reconstruction Project). Estimates from the project engineer working on the improvements indicate the Reconstruction Project may be complete by 2023. These changes are conceptually shown on Figure 1.d.2.

4.2 ROADWAY IMPROVEMENT PROJECTS

In addition to the improvements identified for the O'Brien Highway/Route 28 Reconstruction Project, improvements associated with the Cambridge Redevelopment Authority (CRA) Kendall Square Streetscape Redesign were incorporated into future condition analysis. The 100 percent design plans were obtained from the TP&T department for this analysis.

5.0 TRAFFIC ANALYSIS

5.1 SITE ASSIGNMENT

The 2020 Modified Baseline Condition traffic volumes were combined with the Net New Site Generated traffic levels to derive the 2020 Build condition networks, shown on Figure 5.b.1 and Figure 5.b.2 for the weekday morning and weekday evening peak hour time periods. Figure 5.b.3 and Figure 5.b.4 represent the projected 2020 Build weekday morning and weekday evening, peak-hour pedestrian volumes.

The Future 2025 traffic volume condition includes the traffic volumes from the identified background developments, the increases resulting from the 0.5 percent per year annual growth rate that were applied to the 2020 Modified Baseline conditions traffic volumes, and the net new traffic associated with the Project. These traffic volume networks are shown on Figure 5.d.1 and Figure 5.d.2 for the weekday morning and weekday evening peak-hour traffic volumes.

6.0 CAPACITY ANALYSIS

6.1 VEHICLE LEVEL-OF-SERVICE ANALYSIS

Using the 2020-and 2025-year traffic-volume networks, Vehicle Level-of-Service (LOS) analyses were conducted for the 2020 Existing, 2020 Modified Baseline, 2020 Build, and 2025 Future conditions with the results shown in Tables 6.1 and 6.2 for signalized and unsignalized intersections, respectively. As requested in the City Scoping Letter, these analyses were conducted using SimTraffic analysis software, calibrated to match vehicle queue observations. The analysis worksheets are contained in the Appendix.

Table 6.1
VEHICLE LEVEL-OF-SERVICE SUMMARY – SIGNALIZED INTERSECTIONS

Intersection/Peak Hour/Movement	2020 Existing		2020 Modified Baseline		2020 Build		Delay Increase	2025 Future		
	Delay ^a	LOS ^b	Delay	LOS	Delay	LOS		Delay	LOS	
<i>O'Brien Highway at Museum Way</i>										
<i>Weekday Morning Peak Hour:</i>										
O'Brien Highway EB LT	19	B	19	B	20	B	1	18	B	
O'Brien Highway EB TH	6	A	6	A	6	A	0	6	A	
O'Brien Highway EB TH	6	A	6	A	6	A	0	6	A	
O'Brien Highway WB TH	171	F	172	F	167	F	-5	171	F	
O'Brien Highway WB TH	32	C	34	C	32	C	-2	30	C	
O'Brien Highway WB TH/RT	4	A	3	A	4	A	1	4	A	
Museum Way SB LT/RT	51	D	53	D	51	D	-2	54	D	
Overall	28	C	29	C	29	C	0	31	C	
<i>Weekday Evening Peak Hour:</i>										
O'Brien Highway EB LT	32	C	29	C	31	C	2	30	C	
O'Brien Highway EB TH	7	A	7	A	7	A	0	7	A	
O'Brien Highway EB TH	8	A	7	A	8	A	1	8	A	
O'Brien Highway WB TH	139	F	146	F	134	F	-12	146	F	
O'Brien Highway WB TH	41	D	37	D	49	D	12	30	C	
O'Brien Highway WB TH/RT	26	C	19	B	28	C	9	19	B	
Museum Way SB LT/RT	40	D	44	D	45	D	1	48	D	
Overall	32	C	31	C	34	C	3	31	C	

*See notes at end of table.

Table 6.1 (Continued)
VEHICLE LEVEL-OF-SERVICE SUMMARY – SIGNALIZED INTERSECTIONS

Intersection/Peak Hour/Movement	2020 Existing		2020 Modified Baseline		2020 Build		Delay Increase	2025 Future		
	Delay ^a	LOS ^b	Delay	LOS	Delay	LOS		Delay	LOS	
O'Brien Highway at Land Boulevard /Charlestown Avenue										
<i>Weekday Morning Peak Hour:</i>										
O'Brien Highway EB LT	57	E	59	E	58	E	1	50	D	
O'Brien Highway EB LT	56	E	78	E	55	D	-23	35	C	
O'Brien Highway EB TH	184	F	241	F	213	F	-28	187	F	
O'Brien Highway EB TH	242	F	302	F	273	F	-29	187	F	
O'Brien Highway EB RT	4	A	5	A	5	A	0	4	A	
O'Brien Highway WB LT	85	F	85	F	85	F	0	84	F	
O'Brien Highway WB TH	63	E	59	E	64	E	5	66	E	
O'Brien Highway WB TH	58	E	57	E	55	D	-2	51	D	
O'Brien Highway WB RT	14	B	14	B	14	B	0	13	B	
Land Boulevard NB LT	67	E	63	E	60	E	-3	167	F	
Land Boulevard NB TH	238	F	218	F	198	F	-20	184	F	
Land Boulevard NB TH	261	F	268	F	218	F	-50	202	F	
Land Boulevard NB RT	14	B	17	B	16	B	-1	14	B	
Charlestown Avenue SB LT/TH	48	D	49	D	48	D	-1	50	D	
Charlestown Avenue SB LT/TH	67	E	67	E	67	E	0	71	E	
Charlestown Avenue SB TH/RT	83	F	84	F	84	F	0	89	F	
Overall	105	F	114	F	107	F	-7	98	F	
<i>Weekday Evening Peak Hour:</i>										
O'Brien Highway EB LT	68	E	65	E	78	E	13	71	E	
O'Brien Highway EB LT	115	F	117	F	213	F	96	135	F	
O'Brien Highway EB TH	27	C	27	C	32	C	5	29	C	
O'Brien Highway EB TH	31	C	29	C	28	C	-1	27	C	
O'Brien Highway EB RT	2	A	2	A	2	A	0	3	A	
O'Brien Highway WB LT	86	F	86	F	84	F	-2	85	F	
O'Brien Highway WB TH	77	E	75	E	81	F	6	72	E	
O'Brien Highway WB TH	61	E	58	E	64	E	6	58	E	
O'Brien Highway WB RT	39	D	37	D	39	D	2	36	D	
Land Boulevard NB LT	72	E	75	E	81	F	6	80	F	
Land Boulevard NB TH	270	F	270	F	275	F	5	277	F	
Land Boulevard NB TH	286	F	280	F	283	F	3	288	F	
Land Boulevard NB RT	58	E	51	D	67	E	16	89	F	
Charlestown Avenue SB LT/TH	65	E	57	E	54	D	-3	70	E	
Charlestown Avenue SB LT/TH	98	F	88	F	82	F	-6	109	F	
Charlestown Avenue SB TH/RT	134	F	124	F	118	F	-6	139	F	
Overall	97	F	95	F	105	F	10	103	F	

*See notes at end of table.

Table 6.1 (Continued)
VEHICLE LEVEL-OF-SERVICE SUMMARY – SIGNALIZED INTERSECTIONS

Intersection/Peak Hour/Movement	2020 Existing		2020 Modified Baseline		2020 Build		Delay Increase	2025 Future		
	Delay ^a	LOS ^b	Delay	LOS	Delay	LOS		Delay	LOS	
O'Brien Highway at Cambridge Street /East Street										
<i>Weekday Morning Peak Hour:</i>										
O'Brien Highway EB LT	46	D	42	D	46	D	4	--	--	
O'Brien Highway EB TH	108	F	132	F	73	E	-59	25	C	
O'Brien Highway EB TH	132	F	172	F	101	F	-71	26	C	
O'Brien Highway EB TH	149	F	202	F	128	F	-74	28	C	
O'Brien Highway EB RT	41	D	40	D	44	D	4	--	--	
O'Brien Highway WB LT	38	D	34	C	47	D	13	--	--	
O'Brien Highway WB LT	31	C	29	C	31	C	2	26	C	
O'Brien Highway WB LT/TH	--	--	--	--	--	--	--	26	C	
O'Brien Highway WB TH	20	C	20	B	19	B	-1	17	B	
O'Brien Highway WB TH/RT	16	B	17	B	15	B	-2	--	--	
Cambridge Street NB LT/TH	34	C	38	D	35	C	-3	--	--	
Cambridge Street NB RT	22	C	26	C	25	C	-1	--	--	
Cambridge Street NB RT	25	C	26	C	29	C	3	30	C	
East Street SB LT/TH/RT	56	E	23	C	69	E	46	--	--	
East Street SB LT/TH	--	--	--	--	--	--	--	51	D	
East Street SB TH/RT	--	--	--	--	--	--	--	13	B	
Overall	74	E	93	F	62	E	-31	26	C	
<i>Weekday Evening Peak Hour:</i>										
O'Brien Highway EB LT	33	C	24	C	156	F	132	--	--	
O'Brien Highway EB TH	10	A	11	B	100	F	89	50	D	
O'Brien Highway EB TH	7	A	7	A	58	E	51	41	D	
O'Brien Highway EB TH	48	D	93	F	40	D	-53	38	D	
O'Brien Highway EB RT	148	F	126	F	122	F	-4	--	--	
O'Brien Highway WB LT	60	E	43	D	187	F	144	--	--	
O'Brien Highway WB LT	34	C	28	C	63	E	35	69	E	
O'Brien Highway WB LT/TH	--	--	--	--	--	--	--	32	C	
O'Brien Highway WB TH	24	C	18	B	50	D	32	24	C	
O'Brien Highway WB TH/RT	19	B	33	C	32	C	-1	--	--	
Cambridge Street NB LT/TH	34	C	63	E	36	D	-27	--	--	
Cambridge Street NB RT	30	C	35	D	12	B	-23	--	--	
Cambridge Street NB RT	30	C	29	C	7	A	-22	15	B	
East Street SB LT/TH/RT	31	C	30	C	146	F	116	--	--	
East Street SB LT/TH	--	--	--	--	--	--	--	42	D	
East Street SB TH/RT	--	--	--	--	--	--	--	23	C	
Overall	31	C	29	C	51	D	22	32	C	

*See notes at end of table.

Table 6.1 (Continued)
VEHICLE LEVEL-OF-SERVICE SUMMARY – SIGNALIZED INTERSECTIONS

Intersection/Peak Hour/Movement	2020 Existing		2020 Modified Baseline		2020 Build		Delay Increase	2025 Future		
	Delay ^a	LOS ^b	Delay	LOS	Delay	LOS		Delay	LOS	
<i>O'Brien Highway at North First Street</i>										
<i>Weekday Morning Peak Hour:</i>										
O'Brien Highway EB TH								151	F	
O'Brien Highway EB TH								191	F	
O'Brien Highway EB RT								79	E	
O'Brien Highway WB TH								4	A	
O'Brien Highway WB TH								3	A	
O'Brien Highway WB RT								24	C	
North First Street NB LT								29	C	
North First Street NB TH/RT								32	C	
North First Street SB LT								29	C	
North First Street SB TH/RT								95	F	
Overall								123	F	
Intersection is Constructed under 2025 Future Conditions										
<i>Weekday Evening Peak Hour:</i>										
O'Brien Highway EB TH								98	F	
O'Brien Highway EB TH								92	F	
O'Brien Highway EB RT								64	E	
O'Brien Highway WB TH								16	B	
O'Brien Highway WB TH								21	C	
O'Brien Highway WB RT								7	A	
North First Street NB LT								40	D	
North First Street NB TH/RT								42	D	
North First Street SB LT								860	F	
North First Street SB TH/RT								38	D	
Overall								63	E	

*See notes at end of table.

Table 6.1 (Continued)
VEHICLE LEVEL-OF-SERVICE SUMMARY – SIGNALIZED INTERSECTIONS

Intersection/Peak Hour/Movement	2020 Existing		2020 Modified Baseline		2020 Build		Delay Increase	2025 Future		
	Delay ^a	LOS ^b	Delay	LOS	Delay	LOS		Delay	LOS	
Cambridge Street at First Street										
<i>Weekday Morning Peak Hour:</i>										
Cambridge Street EB LT	--	--	--	--	--	--	--	12	B	
Cambridge Street EB TH/RT	13	B	12	B	16	B	4	33	C	
Cambridge Street WB LT	13	B	13	B	13	B	0	22	C	
Cambridge Street WB TH	7	A	7	A	6	A	-1	--	--	
Cambridge Street WB TH/RT	--	--	--	--	--	--	--	5	A	
First Street NB LT	37	D	39	D	41	D	2	--	--	
First Street NB LT/TH	--	--	--	--	--	--	--	123	F	
First Street NB RT	19	B	18	B	24	C	6	29	C	
Bus Station SB LT/TH/RT	60	E	43	D	45	D	2	--	--	
North First Street SB LT/TH	--	--	--	--	--	--	--	46	D	
North First Street SB RT	--	--	--	--	--	--	--	43	D	
Overall	14	B	14	B	16	B	2	34	C	
<i>Weekday Evening Peak Hour:</i>										
Cambridge Street EB LT	--	--	--	--	--	--	--	55	D	
Cambridge Street EB TH/RT	76	E	86	F	218	F	132	43	D	
Cambridge Street WB LT	21	C	23	C	49	D	26	49	D	
Cambridge Street WB TH	16	B	14	B	15	B	1	--	--	
Cambridge Street WB TH/RT	--	--	--	--	--	--	--	12	B	
First Street NB LT	66	E	71	E	71	E	0	--	--	
First Street NB LT/TH	--	--	--	--	--	--	--	265	F	
First Street NB RT	19	B	21	C	26	C	5	10	B	
Bus Station SB LT/TH/RT	222	F	34	C	39	D	5	--	--	
North First Street SB LT/TH	--	--	--	--	--	--	--	46	D	
North First Street SB RT	--	--	--	--	--	--	--	32	C	
Overall	34	C	37	D	62	E	25	73	E	

*See notes at end of table.

Table 6.1 (Continued)
VEHICLE LEVEL-OF-SERVICE SUMMARY – SIGNALIZED INTERSECTIONS

Intersection/Peak Hour/Movement	2020 Existing		2020 Modified Baseline		2020 Build		Delay Increase	2025 Future		
	Delay ^a	LOS ^b	Delay	LOS	Delay	LOS		Delay	LOS	
<i>O'Brien Highway at Third Street</i>										
<i>Weekday Morning Peak Hour:</i>										
O'Brien Highway EB LT/TH	--	--	--	--	--	--	--	67	E	
O'Brien Highway EB TH	70	E	72	E	87	F	15	76	E	
O'Brien Highway EB TH	64	E	70	E	92	F	22	--	--	
O'Brien Highway EB TH/RT	83	F	85	F	116	F	31	--	--	
O'Brien Highway EB RT	--	--	--	--	--	--	--	17	B	
O'Brien Highway WB LT/TH	13	B	12	B	11	B	-1	--	--	
O'Brien Highway WB TH	12	B	12	B	11	B	-1	--	--	
O'Brien Highway WB TH	13	B	13	B	13	B	0	8	A	
O'Brien Highway WB TH/RT	--	--	--	--	--	--	--	4	A	
Third Street NB LT	22	C	22	C	24	C	2	26	C	
Third Street NB LT/TH/RT	--	--	--	--	--	--	--	53	D	
Third Street NB LT/RT	38	D	37	D	38	D	1	--	--	
Private Driveway SB LT/THRT	--	--	--	--	--	--	--	49	D	
Overall	58	E	60	E	77	E	17	50	D	
<i>Weekday Evening Peak Hour:</i>										
O'Brien Highway EB LT/TH	--	--	--	--	--	--	--	77	E	
O'Brien Highway EB TH	37	D	36	D	35	D	-1	23	C	
O'Brien Highway EB TH	28	C	28	C	27	C	-1	--	--	
O'Brien Highway EB TH/RT	24	C	24	C	23	C	-1	--	--	
O'Brien Highway EB RT	--	--	--	--	--	--	--	8	A	
O'Brien Highway WB LT/TH	51	D	57	E	47	D	-1	--	--	
O'Brien Highway WB TH	46	D	50	D	41	D	-11	--	--	
O'Brien Highway WB TH	49	D	54	D	44	D	-10	31	C	
O'Brien Highway WB TH/RT	--	--	--	--	--	--	--	33	C	
Third Street NB LT	16	B	17	B	16	B	-9	19	B	
Third Street NB LT/TH/RT	--	--	--	--	--	--	--	34	C	
Third Street NB LT/RT	17	B	17	B	16	B	-10	--	--	
Private Driveway SB LT/THRT	--	--	--	--	--	--	--	35	C	
Overall	36	D	38	D	33	C	-5	31	C	

*See notes at end of table.

Table 6.1 (Continued)
VEHICLE LEVEL-OF-SERVICE SUMMARY – SIGNALIZED INTERSECTIONS

Intersection/Peak Hour/Movement	2020 Existing		2020 Modified Baseline		2020 Build		Delay Increase	2025 Future		
	Delay ^a	LOS ^b	Delay	LOS	Delay	LOS		Delay	LOS	
Cambridge Street at Third Street										
<i>Weekday Morning Peak Hour:</i>										
Cambridge Street EB LT/TH/RT	33	C	27	C	30	C	3	42	D	
Cambridge Street WB LT/TH/RT	37	D	30	C	40	D	10	155	F	
Third Street NB LT/TH/RT	86	F	45	D	51	D	6	149	F	
Third Street SB LT	17	B	19	B	18	B	-1	25	C	
Third Street SB TH/RT	29	C	27	C	25	C	-2	38	D	
Overall	36	D	29	C	31	C	2	75	E	
<i>Weekday Evening Peak Hour:</i>										
Cambridge Street EB LT/TH/RT	123	F	137	F	163	F	26	56	E	
Cambridge Street WB LT/TH/RT	27	C	31	C	29	C	-2	33	C	
Third Street NB LT/TH/RT	26	C	26	C	33	C	7	51	D	
Third Street SB LT	40	D	47	D	54	D	7	96	F	
Third Street SB TH/RT	15	B	15	B	16	B	1	14	B	
Overall	38	D	41	D	45	D	4	40	D	
First Street at Thorndike Street										
<i>Weekday Morning Peak Hour:</i>										
Thorndike Street EB LT	13	B	17	B	16	B	-1	14	B	
Thorndike Street EB RT	6	A	6	A	7	A	1	7	A	
First Street NB TH	5	A	5	A	5	A	0	6	A	
First Street SB TH	7	A	8	A	8	A	0	8	A	
Overall	7	A	7	A	8	A	1	8	A	
<i>Weekday Evening Peak Hour:</i>										
Thorndike Street EB LT	20	C	21	C	25	C	4	55	D	
Thorndike Street EB RT	50	D	57	E	224	F	167	28	C	
First Street NB TH	19	B	19	B	25	C	6	67	E	
First Street SB TH	56	E	54	D	156	F	102	52	D	
Overall	30	C	30	C	68	E	38	57	E	

*See notes at end of table.

Table 6.1 (Continued)
VEHICLE LEVEL-OF-SERVICE SUMMARY – SIGNALIZED INTERSECTIONS

Intersection/Peak Hour/Movement	2020 Existing		2020 Modified Baseline		2020 Build		Delay Increase	2025 Future		
	Delay ^a	LOS ^b	Delay	LOS	Delay	LOS		Delay	LOS	
<i>First Street at Charles Street and Cambridgeside Place</i>										
<i>Weekday Morning Peak Hour:</i>										
Charles Street EB LT/TH/RT	14	B	14	B	15	B	1	15	B	
Cambridgeside Place WB LT/ RT	11	B	11	B	11	B	0	12	B	
First Street NB TH/RT	7	A	8	A	9	A	1	10	A	
First Street SB LT/TH	9	A	12	B	12	B	0	15	B	
Overall	10	A	10	B	11	B	1	12	B	
<i>Weekday Evening Peak Hour:</i>										
Charles Street EB LT/TH/RT	185	F	164	F	271	F	107	334	F	
Cambridgeside Place WB LT/ RT	23	C	21	C	29	C	8	92	F	
First Street NB TH/RT	59	E	57	E	201	F	144	500	F	
First Street SB LT/TH	105	F	106	F	184	F	78	82	F	
Overall	67	E	65	E	123	F	58	229	F	

*See notes at end of table.

Table 6.1 (Continued)

VEHICLE LEVEL-OF-SERVICE SUMMARY – SIGNALIZED INTERSECTIONS

Intersection/Peak Hour/Movement	2020 Existing		2020 Modified Baseline		2020 Build		Delay Increase	2025 Future		
	Delay ^a	LOS ^b	Delay	LOS	Delay	LOS		Delay	LOS	
<i>Land Boulevard at Cambridgeside Place and Hotel Driveway</i>										
<i>Weekday Morning Peak Hour:</i>										
Cambridgeside Place EB LT	36	D	38	D	37	D	-1	39	D	
Cambridgeside Place EB LT/TH	33	C	34	C	34	C	0	34	C	
Cambridgeside Place EB RT	1	A	1	A	1	A	0	1	A	
Hotel Driveway WB LT/TH/RT	23	C	30	C	28	C	-2	26	C	
Land Boulevard NB LT	55	E	53	D	174	F	121	170	F	
Land Boulevard NB TH	16	B	15	B	282	F	267	189	F	
Land Boulevard NB TH	16	B	14	B	15	B	1	17	B	
Land Boulevard NB TH/RT	15	B	14	B	13	B	-1	14	B	
Land Boulevard SB LT	54	D	48	D	52	D	4	48	D	
Land Boulevard SB TH	8	A	7	A	8	A	1	9	A	
Land Boulevard SB TH	10	A	9	A	10	A	1	11	B	
Land Boulevard SB TH/RT	10	A	9	A	10	A	1	9	A	
Overall	18	B	17	B	38	D	21	42	D	
<i>Weekday Evening Peak Hour:</i>										
Cambridgeside Place EB LT	94	F	92	F	118	F	26	138	F	
Cambridgeside Place EB LT/TH	65	E	61	E	92	F	31	110	F	
Cambridgeside Place EB RT	1	A	1	A	1	A	0	1	A	
Hotel Driveway WB LT/TH/RT	44	D	53	D	62	E	9	72	E	
Land Boulevard NB LT	103	F	123	F	146	F	23	153	F	
Land Boulevard NB TH	35	C	34	C	62	E	28	241	F	
Land Boulevard NB TH	35	C	30	C	52	D	22	190	F	
Land Boulevard NB TH/RT	24	C	23	C	30	C	7	123	F	
Land Boulevard SB LT	56	E	53	D	62	E	9	80	F	
Land Boulevard SB TH	12	B	12	B	11	B	-1	10	B	
Land Boulevard SB TH	14	B	13	B	13	B	0	13	B	
Land Boulevard SB TH/RT	8	A	7	A	7	A	0	9	B	
Overall	33	C	33	C	44	D	11	99	F	

*See notes at end of table.

Table 6.1 (Continued)

VEHICLE LEVEL-OF-SERVICE SUMMARY – SIGNALIZED INTERSECTIONS

Intersection/Peak Hour/Movement	2020 Existing		2020 Modified Baseline		2020 Build		Delay Increase	2025 Future		
	Delay ^a	LOS ^b	Delay	LOS	Delay	LOS		Delay	LOS	
<i>Land Boulevard at Binney Street</i>										
<i>Weekday Morning Peak Hour:</i>										
Binney Street EB LT	29	C	26	C	33	C	7	40	D	
Binney Street EB LT	32	C	31	C	30	C	-1	34	C	
Land Boulevard NB LT	98	F	99	F	103	F	4	107	F	
Land Boulevard NB LT	95	F	99	F	101	F	2	104	F	
Land Boulevard NB TH	24	C	24	C	26	C	2	30	C	
Land Boulevard NB TH	18	B	18	B	17	B	-1	19	B	
Land Boulevard NB TH	18	B	16	B	15	B	-1	17	B	
Land Boulevard SB TH	41	D	38	D	38	D	0	41	D	
Land Boulevard SB TH	45	D	41	D	43	D	2	45	D	
Land Boulevard SB RT	24	C	22	B	24	C	2	22	C	
Overall	54	D	54	D	55	D	1	56	E	
<i>Weekday Evening Peak Hour:</i>										
Binney Street EB LT	48	D	53	D	52	D	-1	70	E	
Binney Street EB LT	51	D	54	D	51	D	-3	56	E	
Land Boulevard NB LT	35	D	32	C	38	D	6	45	D	
Land Boulevard NB LT	28	C	26	C	40	D	14	90	F	
Land Boulevard NB TH	17	B	16	B	18	B	2	103	F	
Land Boulevard NB TH	12	B	12	B	13	B	1	62	E	
Land Boulevard NB TH	10	B	10	B	11	B	1	55	D	
Land Boulevard SB TH	15	B	17	B	17	B	0	22	C	
Land Boulevard SB TH	18	B	20	B	20	B	0	26	C	
Land Boulevard SB RT	7	A	8	A	11	B	3	21	C	
Overall	20	B	20	B	22	B	2	53	D	

*See notes at end of table.

Table 6.1 (Continued)
VEHICLE LEVEL-OF-SERVICE SUMMARY – SIGNALIZED INTERSECTIONS

Intersection/Peak Hour/Movement	2020 Existing		2020 Modified Baseline		2020 Build		Delay Increase	2025 Future		
	Delay ^a	LOS ^b	Delay	LOS	Delay	LOS		Delay	LOS	
<i>Binney Street at First Street</i>										
<i>Weekday Morning Peak Hour:</i>										
Binney Street EB LT	25	C	30	C	34	C	4	36	D	
Binney Street EB TH	18	B	21	B	20	C	-1	23	C	
Binney Street EB TH/RT	15	B	16	B	16	B	0	17	B	
Binney Street WB LT/TH	9	A	8	A	9	A	1	10	A	
Binney Street WB TH/RT	6	A	6	A	6	A	0	6	A	
First Street NB LT/TH/RT	44	D	45	D	42	D	-3	59	E	
First Street SB LT/TH	36	D	40	D	37	D	-3	40	D	
First Street SB RT	5	A	5	A	5	A	0	6	A	
Overall	13	B	14	B	15	B	1	17	B	
<i>Weekday Evening Peak Hour:</i>										
Binney Street EB LT	21	C	20	B	53	D	33	188	F	
Binney Street EB TH	17	B	19	B	28	C	9	89	F	
Binney Street EB TH/RT	11	B	12	B	12	B	0	15	B	
Binney Street WB LT/TH	5	A	7	A	8	A	1	10	B	
Binney Street WB TH/RT	5	A	6	A	12	B	6	42	D	
First Street NB LT/TH/RT	31	C	44	D	32	C	-12	198	F	
First Street SB LT/TH	69	E	75	E	94	F	19	88	F	
First Street SB RT	4	A	4	A	5	A	1	5	A	
Overall	25	C	28	C	35	D	7	62	E	

*See notes at end of table.

Table 6.1 (Continued)
VEHICLE LEVEL-OF-SERVICE SUMMARY – SIGNALIZED INTERSECTIONS

Intersection/Peak Hour/Movement	2020 Existing		2020 Modified Baseline		2020 Build		Delay Increase	2025 Future		
	Delay ^a	LOS ^b	Delay	LOS	Delay	LOS		Delay	LOS	
<i>Binney Street at Second Street</i>										
<i>Weekday Morning Peak Hour:</i>										
Binney Street EB LT	36	D	31	C	36	D	5	33	C	
Binney Street EB TH/RT	24	C	24	C	26	B	2	30	C	
Binney Street WB LT	39	D	36	D	37	D	1	41	D	
Binney Street WB TH	26	C	26	C	27	C	1	26	C	
Binney Street WB TH/RT	25	C	25	C	25	C	0	25	C	
Second Street NB LT/TH/RT	26	C	29	C	26	C	-3	26	C	
Second Street SB LT/TH/RT	29	C	32	C	31	C	-1	32	C	
Overall	27	C	27	C	28	C	1	29	C	
<i>Weekday Evening Peak Hour:</i>										
Binney Street EB LT	33	C	33	C	35	C	2	42	D	
Binney Street EB TH/RT	23	C	23	C	27	C	4	108	F	
Binney Street WB LT	36	D	41	D	36	D	-5	33	C	
Binney Street WB TH	22	C	23	C	22	C	-1	24	C	
Binney Street WB TH/RT	17	B	19	B	18	B	-1	20	B	
Second Street NB LT/TH/RT	34	C	37	D	35	D	-2	74	E	
Second Street SB LT/TH/RT	39	D	42	D	36	D	-6	107	F	
Overall	27	C	29	C	28	C	-1	69	E	

*See notes at end of table.

Table 6.1 (Continued)
VEHICLE LEVEL-OF-SERVICE SUMMARY – SIGNALIZED INTERSECTIONS

Intersection/Peak Hour/Movement	2020 Existing		2020 Modified Baseline		2020 Build		Delay Increase	2025 Future		
	Delay ^a	LOS ^b	Delay	LOS	Delay	LOS		Delay	LOS	
<i>Binney Street at Third Street</i>										
<i>Weekday Morning Peak Hour:</i>										
Binney Street EB LT	33	C	31	C	33	C	2	35	D	
Binney Street EB TH	25	C	26	C	26	C	0	32	C	
Binney Street EB TH/RT	22	C	23	C	23	C	0	26	C	
Binney Street WB LT	39	D	38	D	39	D	1	47	D	
Binney Street WB TH	26	C	25	C	25	C	0	28	C	
Binney Street WB TH/RT	25	C	26	C	25	C	-1	25	C	
Third Street NB LT/TH	40	D	45	D	50	D	5	137	F	
Third Street NB RT	3	A	5	A	8	A	3	267	F	
Third Street SB LT/TH/RT	33	C	33	C	33	C	0	78	E	
Overall	27	C	27	C	28	C	1	81	F	
<i>Weekday Evening Peak Hour:</i>										
Binney Street EB LT	66	E	65	E	67	E	2	95	F	
Binney Street EB TH	58	E	58	E	154	F	96	1,072	F	
Binney Street EB TH/RT	22	C	24	C	24	C	0	150	F	
Binney Street WB LT	32	C	32	C	30	C	-2	31	C	
Binney Street WB TH	25	C	26	C	27	C	1	25	C	
Binney Street WB TH/RT	26	C	24	C	25	C	1	24	C	
Third Street NB LT/TH	26	C	30	C	26	C	-4	50	D	
Third Street NB RT	28	C	41	D	34	C	-7	455	F	
Third Street SB LT/TH/RT	33	C	32	C	33	C	1	138	F	
Overall	37	D	38	D	43	D	5	167	F	

*See notes at end of table.

Table 6.1 (Continued)
VEHICLE LEVEL-OF-SERVICE SUMMARY – SIGNALIZED INTERSECTIONS

Intersection/Peak Hour/Movement	2020 Existing		2020 Modified Baseline		2020 Build		Delay Increase	2025 Future		
	Delay ^a	LOS ^b	Delay	LOS	Delay	LOS		Delay	LOS	
<i>Broadway at Third Street</i>										
<i>Weekday Morning Peak Hour:</i>										
Broadway EB LT	32	C	31	C	30	C	-1	104	F	
Broadway EB TH	20	B	20	B	19	B	-1	27	C	
Broadway EB TH/RT	2	A	3	A	3	A	0	3	A	
Broadway WB TH	24	C	23	C	24	C	1	60	E	
Broadway WB RT	19	B	19	B	21	C	2	101	F	
Third Street SB LT/TH	24	C	24	C	22	C	-2	48	D	
Third Street SB RT	10	B	11	B	10	A	1	8	A	
Overall	22	C	22	C	22	C	0	58	E	
<i>Weekday Evening Peak Hour:</i>										
Broadway EB LT	33	C	34	C	32	C	-2	51	D	
Broadway EB TH	23	C	22	C	23	C	1	25	C	
Broadway EB TH/RT	4	A	4	A	5	A	1	4	A	
Broadway WB TH	20	B	19	B	20	C	1	22	C	
Broadway WB RT	18	B	18	B	17	B	-1	28	C	
Third Street SB LT/TH	33	C	35	C	34	C	-1	42	D	
Third Street SB RT	8	A	10	A	10	B	0	9	A	
Overall	24	C	24	C	24	C	0	29	C	

^aAverage delay per vehicle (in seconds).

^bLevel of service.

NB = northbound; SB = southbound; WB = westbound; SB = southbound; LT = left-turn movement; TH = through movement; RT = right-turn movement.

Table 6.2
VEHICLE LEVEL-OF-SERVICE SUMMARY - UNSIGNALIZED INTERSECTIONS

Unsignalized Intersection/ Critical Movement/Peak Hour	2020 Existing			2020 Modified Baseline			2020 Build			Delay Increase	2025 Future		
	Demand ^a	Delay ^b	LOS ^c	Demand	Delay	LOS	Demand	Delay	LOS		Demand	Delay	LOS
First Street at Spring Street/Upper Garage													
Weekday Morning Peak Hour:													
Upper Garage WB LT/TH/RT	2	13	B	2	11	B	Upper Garage is Closed Under 2020 Build Conditions			--	Upper Garage is Closed Under 2025 Future Conditions		
Weekday Evening Peak Hour:													
Upper Garage WB LT/TH/RT	67	91	F	67	96	F				--			
Cambridgeside Place at Lower Garage South Exit													
Weekday Morning Peak Hour:													
Lower Garage South Exit SB LT	5	4	A	10	4	A	27	4	A	0	27	4	A
Lower Garage South Exit SB RT	4	2	A	8	3	A	23	3	A	0	23	2	A
Weekday Evening Peak Hour:													
Lower Garage South Exit SB LT	229	152	F	252	176	F	295	146	F	-30	295	10	B
Lower Garage South Exit SB RT	109	10	B	122	19	B	206	26	C	7	206	2,880	F
First Street at Lower Garage West Entrance													
Weekday Morning Peak Hour:													
First Street NB TH/RT	333	1	A	344	2	A	394	2	A	0	474	2	A
First Street SB LT/TH	197	1	A	207	2	A	254	3	A	1	341	3	A
Weekday Evening Peak Hour:													
First Street NB TH/RT	383	5	A	389	6	A	485	14	B	8	579	67	F
First Street SB LT/TH	186	56	F	183	51	F	234	55	F	4	297	35	C
Cambridgeside Place at Lower Garage South Entrance													
Weekday Morning Peak Hour:													
Cambridgeside Place EB TH ^d	105	2	A	110	2	A	128	3	A	1	134	3	A
Cambridgeside Place EB TH		4	A		5	A		5	A	0		5	A
Cambridgeside Place EB TH		1	A		1	A		1	A	0		1	A
Cambridgeside Place WB TH	164	1	A	164	1	A	164	1	A	0	185	1	A
Cambridgeside Place WB RT	189	1	A	213	1	A	262	1	A	0	262	1	A
Weekday Evening Peak Hour:													
Cambridgeside Place EB TH	500	293	F	523	298	F	560	354	F	56	581	350	F
Cambridgeside Place EB TH		272	F		274	F		386	F	112		385	F
Cambridgeside Place EB TH		3	A		3	A		3	A	0		2	A
Cambridgeside Place WB TH	125	1	A	125	1	A	125	1	A	0	136	7	A
Cambridgeside Place WB RT	121	1	A	115	1	A	131	1	A	0	131	1	A

^aDemand (in vehicles per hour) for the critical movements.

^bAverage delay per vehicle (in seconds) for the critical movements.

^cLevel of service.

^dEastbound movement not technically part of intersection due to median present on Cambridgeside Place.

NB = northbound; SB = southbound; WB = westbound; SB = southbound; LT = left-turn movement; TH = through movement; RT = right-turn movement.

Figure 6.a.1 through Figure 6.a.2 depict the vehicle LOS summaries in a graphical map format for the weekday morning, weekday evening, and Saturday midday peak hours. Figure 6.a.3 through Figure 6.a.4 provide graphical maps of vehicle delay changes at the study area intersections for the weekday morning, weekday evening, and Saturday midday peak hours. These delay change maps depict the change in delay from Existing to Build and from Existing to Future conditions.

6.2 TRAFFIC SIGNAL WARRANT ANALYSIS

A peak hour traffic signal warrant analysis was conducted for the intersection of First Street and the Lower Garage West Entrance under 2025 Future conditions. The Manual on Uniform Traffic Control Devices (MUTCD) establishes nine warrants or criteria to evaluate a location for the installation or retention of a traffic signal. At least one of the nine warrants should be satisfied in order to justify the installation or retention of a traffic signal; however, satisfaction of a warrant in and of itself does not justify traffic signal control. An engineering evaluation of the location in question should indicate that the establishment of traffic signal control will improve the overall safety and/or operation of the intersection. Table 6.3 identifies the nine traffic signal warrants. Table 6.4 summarizes the traffic signal warrant analysis.

Table 6.3
TRAFFIC SIGNAL WARRANTS

Warrant No.	Description
1	Eight-Hour Vehicular Volume
2	Four-Hour Vehicular Volume
3	Peak Hour
4	Pedestrian Volume
5	School Crossing
6	Coordinated Signal System
7	Crash Experience
8	Roadway Network
9	Intersection near a Grade Crossing

Table 6.4
TRAFFIC SIGNAL WARRANTS ANALYSIS RESULTS^a
FIRST STREET AT LOWER GARAGE WEST ENTRANCE

Warrant No.	Description	Satisfied for 2025 Future Conditions
1	Eight-Hour Vehicular Volume	--
2	Four-Hour Vehicular Volume	--
3	Peak Hour	No
4	Pedestrian Volume	No
5	School Crossing	No
6	Coordinated Signal System	No
7	Crash Experience	No
8	Roadway Network	No
9	Grade Crossing	No

^aTSWA based on traffic volumes from Figure 5.d.1 and Figure 5.d.2 from the TIS.

As can be seen from Table 6.4 the peak hour traffic volume warrant is not met. The 8-hour and 4-hour traffic volume warrants were not checked since the minimum minor street volume to meet the 8-hour warrant at 100 percent is 75 and at 80 percent (which can only be applied after an adequate trial of other remedial measures) is 60. In order to meet the 4-hour warrant the minimum minor street volume is 80 vehicles. Technically there is no minor street volume as the garage is entrance-only, however there is a condition that states if there is a heavy left-turn volume from the major street then the left turn volume can be considered the minor street volume and the single direction of opposing traffic on the major street the major street volume. Even if we apply this condition the maximum left turn volume during the peak hours is 72 vehicles which is lower than the minimum threshold of 75 and 80 vehicles defined for the 8-hour and 4-hour warrants. Therefore, a signal is not warranted at this location.

7.0 QUEUE ANALYSIS

Vehicle queues were calculated for each approach of the signalized study area intersections using SimTraffic simulation software. The analyses were calibrated in an attempt to match the results of the queue observations. Table 7 summarizes the 2018/2019 Existing observed, 2020 Modified Baseline calculated, 2020 Build calculated, and 2025 Future calculated vehicle queues.

Table 7
QUEUE ANALYSIS RESULTS^a

Intersection/Lane	Weekday Morning Peak Hour						Weekday Evening Peak Hour					
	2018/2019 Observed	2020 Existing Calculated	2020 Modified Baseline Calculated	2020 Build Calculated	Increase	2025 Future Calculated	2018/2019 Observed	2020 Existing Calculated	2020 Modified Baseline Calculated	2020 Build Calculated	Increase	2025 Future Calculated
<i>O'Brien Highway at Museum Way:</i>												
O'Brien Highway EB LT	--	1	2	2	0	2	--	2	2	2	0	2
O'Brien Highway EB LT/TH	3	--	--	--	--	--	4	--	--	--	--	--
O'Brien Highway EB TH	2	5	5	5	0	5	3	4	4	4	0	4
O'Brien Highway EB TH	1	5	5	5	0	5	1	5	5	5	0	5
O'Brien Highway WB TH	9	10	10	10	0	10	7	10	10	10	0	10
O'Brien Highway WB TH	8	6	7	6	-1	7	10	9	9	9	0	9
O'Brien Highway WB TH/RT	11	2	2	2	0	2	11	6	5	7	2	6
Museum Way SB LT/RT	--	7	7	7	0	7	--	4	4	5	1	5
Museum Way SB LT	5	--	--	--	--	--	3	--	--	--	--	--
Museum Way SB RT	1	--	--	--	--	--	2	--	--	--	--	--
<i>O'Brien Highway at Land Boulevard</i>												
<i>/Charlestown Avenue:</i>												
O'Brien Highway EB LT	--	3	3	3	0	3	--	9	9	9	0	9
O'Brien Highway EB LT	4	14	19	19	0	9	10	18	17	27	10	20
O'Brien Highway EB LT/TH	10	--	--	--	--	--	11	--	--	--	--	--
O'Brien Highway EB TH	10	24	27	28	1	21	7	13	13	20	7	11
O'Brien Highway EB TH	8	25	27	29	2	22	5	11	10	15	5	9
O'Brien Highway EB RT	3	12	16	16	0	9	1	0	0	0	0	0
O'Brien Highway WB LT	5	--	--	--	--	--	6	8	8	8	0	--
O'Brien Highway WB LT	6	8	8	8	0	8	5	--	6	7	1	8
O'Brien Highway WB TH	7	4	3	4	1	5	9	7	--	--	--	6
O'Brien Highway WB TH	4	4	4	4	0	3	6	6	6	6	0	6
O'Brien Highway WB RT	4	4	4	4	0	3	7	6	6	6	0	6
Land Boulevard NB LT	3	5	6	4	-2	12	8	23	23	24	1	23
Land Boulevard NB TH	18	18	16	14	-2	14	19	32	32	32	0	32
Land Boulevard NB TH	18	18	16	15	-1	14	19	32	32	32	0	32
Land Boulevard NB RT	2	5	5	5	0	5	8	27	23	27	4	31
Charlestown Avenue SB LT/TH	--	10	10	10	0	9	--	8	7	6	-1	9
Charlestown Avenue SB LT/TH	20	16	16	16	0	18	20	16	14	14	0	16
Charlestown Avenue SB TH/RT	20	16	16	16	0	17	20	16	16	15	-1	16

^aSee notes at end of table.

Table 7 (Continued)
QUEUE ANALYSIS RESULTS^A

Intersection/Lane	Weekday Morning Peak Hour						Weekday Evening Peak Hour					
	2018/2019 Observed	2020 Existing Calculated	2020 Modified Baseline Calculated	2020 Build Calculated	Increase	2025 Future Calculated	2018/2019 Observed	2020 Existing Calculated	2020 Modified Baseline Calculated	2020 Build Calculated	Increase	2025 Future Calculated
<i>O'Brien Highway at Cambridge Street /East Street:</i>												
O'Brien Highway EB LT	2	--	3	--	0	--	1	4	4	5	1	--
O'Brien Highway EB TH	8	6	16	6	-6	2	4	10	8	14	6	4
O'Brien Highway EB TH	11	5	18	5	-6	4	6	9	7	13	6	5
O'Brien Highway EB TH	12	5	19	5	-6	6	7	7	5	11	6	6
O'Brien Highway EB RT	2	--	2	--	1	--	2	1	1	2	1	--
O'Brien Highway WB LT	5	--	3	--	0	--	2	2	3	5	2	--
O'Brien Highway WB LT	3	3	2	4	1	4	4	3	4	6	2	5
O'Brien Highway WB LT/TH	--	4	--	10	--	4	--	--	--	--	--	11
O'Brien Highway WB TH	2	3	2	9	0	4	6	7	7	12	5	10
O'Brien Highway WB TH/RT	2	--	2	--	0	--	8	8	7	10	3	--
Cambridge Street NB LT/TH	3	--	2	--	0	--	2	3	3	3	0	--
Cambridge Street NB RT	3	--	1	--	1	--	3	2	2	2	0	--
Cambridge Street NB RT	2	5	1	5	0	5	3	1	1	1	0	5
East Street SB LT/TH/RT	1	--	2	--	0	--	2	2	2	2	0	--
East Street SB LT/TH	--	2	--	3	--	2	--	--	--	--	--	4
East Street SB TH/RT	--	1	--	3	--	1	--	--	--	--	--	2
<i>O'Brien Highway at North First Street:</i>												
O'Brien Highway EB TH						29						18
O'Brien Highway EB TH						29						19
O'Brien Highway EB RT						11						6
O'Brien Highway WB TH						1						6
O'Brien Highway WB TH						1						6
O'Brien Highway WB RT						1						1
North First Street NB LT						1						3
North First Street NB TH/RT						2						2
North First Street SB LT						1						4
North First Street SB TH/RT						2						1

⁸See notes at end of table.

Table 7 (Continued)
QUEUE ANALYSIS RESULTS^A

Intersection/Lane	Weekday Morning Peak Hour						Weekday Evening Peak Hour					
	2018/2019 Observed	2020 Existing Calculated	2020 Modified Baseline Calculated	2020 Build Calculated	Increase	2025 Future Calculated	2018/2019 Observed	2020 Existing Calculated	2020 Modified Baseline Calculated	2020 Build Calculated	Increase	2025 Future Calculated
Cambridge Street at First Street:												
Cambridge Street EB LT	--	--	--	--	--	2	--	--	--	--	--	4
Cambridge Street EB TH/RT	3	4	3	5	2	5	10	9	9	14	5	4
Cambridge Street WB LT	2	4	4	4	0	4	5	3	3	3	0	4
Cambridge Street WB TH	1	2	2	2	0	--	4	3	3	2	-1	--
Cambridge Street WB TH/RT	--	--	--	--	--	2	--	--	--	--	--	3
First Street NB LT	2	1	1	2	1	--	5	5	5	5	0	--
First Street NB LT/TH	--	--	--	--	--	7	--	--	--	--	0	18
First Street NB RT	2	3	3	3	0	3	6	7	8	8	--	2
Bus Station SB LT/TH/RT	0	0	0	0	0	--	0	0	0	0	0	--
North First Street SB LT/TH	--	--	--	--	--	2	--	--	--	--	--	1
North First Street SB RT	--	--	--	--	--	2	--	--	--	--	--	1
O'Brien Highway at Third Street:												
O'Brien Highway EB LT/TH	--	--	--	--	--	15	--	--	--	--	--	9
O'Brien Highway EB TH	11	13	14	16	2	16	7	7	7	7	0	8
O'Brien Highway EB TH	11	13	14	18	4	--	7	6	6	6	0	--
O'Brien Highway EB TH/RT	11	15	15	19	4	--	5	6	6	6	0	--
O'Brien Highway EB RT	--	--	--	--	--	13	--	--	--	--	--	4
O'Brien Highway WB LT/TH	2	2	2	2	0	--	6	13	13	13	0	--
O'Brien Highway WB TH	3	1	2	2	0	--	12	13	14	12	-2	--
O'Brien Highway WB TH	1	2	2	2	0	1	12	14	14	13	-1	17
O'Brien Highway WB TH/RT	--	--	--	--	--	1	--	--	--	--	--	17
Third Street NB LT	3	2	2	2	0	3	5	4	4	3	-1	5
Third Street NB LT/TH/RT	--	--	--	--	--	7	--	--	--	--	--	12
Third Street NB LT/RT	1	4	10	4	-6	--	6	7	7	6	-1	--
Private Driveway SB LT/TH/RT	--	--	--	--	--	1	--	--	--	--	--	1

⁸See notes at end of table.

Table 7 (Continued)
QUEUE ANALYSIS RESULTS^A

Intersection/Lane	Weekday Morning Peak Hour						Weekday Evening Peak Hour					
	2018/2019 Observed	2020 Existing Calculated	2020 Modified Baseline Calculated	2020 Build Calculated	Increase	2025 Future Calculated	2018/2019 Observed	2020 Existing Calculated	2020 Modified Baseline Calculated	2020 Build Calculated	Increase	2025 Future Calculated
Cambridge Street at Third Street:												
Cambridge Street EB LT/TH/RT	10	9	8	9	1	11	8	10	10	10	0	6
Cambridge Street WB LT/TH/RT	4	6	5	6	1	17	9	9	9	8	-1	9
Third Street NB LT/TH/RT	3	5	4	4	0	10	10	9	9	0	0	11
Third Street SB LT	1	2	2	2	0	3	1	1	1	1	0	1
Third Street SB TH/RT	9	10	9	9	0	12	4	4	4	4	0	4
First Street at Thorndike Street:												
Thorndike Street EB LT	1	1	1	1	0	1	2	2	2	2	0	4
Thorndike Street EB RT	1	2	2	2	0	2	2	2	2	5	3	2
First Street NB TH	1	2	2	2	0	2	17	12	11	14	3	25
First Street SB TH	5	3	4	4	0	4	6	7	7	10	3	8
First Street at Charles Street and Cambridgeside Place:												
Charles Street EB LT/TH/RT	3	2	2	2	0	3	5	7	6	8	2	12
Cambridgeside Place WB LT/ RT	2	3	3	3	0	3	8	6	5	6	1	8
First Street NB TH/RT	4	3	3	3	0	4	6	5	5	12	7	27
First Street SB LT/TH	3	2	3	3	0	4	6	6	7	7	0	6
Land Boulevard at Cambridgeside Place and Hotel Driveway:												
Cambridgeside Place EB LT	3	2	2	2	0	2	10	12	12	11	-1	10
Cambridgeside Place EB LT/TH	3	2	2	2	0	2	8	12	12	11	-1	11
Cambridgeside Place EB RT	0	0	0	0	0	0	0	0	0	0	0	0
Hotel Driveway WB LT/TH/RT	1	1	2	1	-1	1	2	2	2	3	1	3
Land Boulevard NB LT	2	4	4	10	6	10	11	7	7	9	2	10
Land Boulevard NB TH	3	3	3	22	19	23	13	8	10	14	4	30
Land Boulevard NB TH	4	3	3	16	13	17	13	7	8	12	4	27
Land Boulevard NB TH/RT	3	3	3	3	0	5	4	5	5	7	2	24
Land Boulevard SB LT	9	9	6	8	2	5	4	5	4	6	2	7
Land Boulevard SB TH	10	9	7	9	2	8	6	7	6	6	0	8
Land Boulevard SB TH	10	11	9	10	1	10	8	7	7	5	-2	9
Land Boulevard SB TH/RT	2	2	2	2	0	2	3	2	2	2	0	2

⁸See notes at end of table.

Table 7 (Continued)
QUEUE ANALYSIS RESULTS^A

Intersection/Lane	Weekday Morning Peak Hour						Weekday Evening Peak Hour					
	2018/2019 Observed	2020 Existing Calculated	2020 Modified Baseline Calculated	2020 Build Calculated	Increase	2025 Future Calculated	2018/2019 Observed	2020 Existing Calculated	2020 Modified Baseline Calculated	2020 Build Calculated	Increase	2025 Future Calculated
Land Boulevard at Binney Street:												
Binney Street EB LT	2	3	2	3	1	4	2	3	3	3	0	3
Binney Street EB LT	2	3	3	3	0	4	2	3	3	3	0	4
Land Boulevard NB LT	18	17	17	18	1	18	5	6	6	6	0	8
Land Boulevard NB LT	13	17	17	17	0	18	7	4	4	5	1	11
Land Boulevard NB TH	4	12	11	13	2	15	11	10	10	10	0	16
Land Boulevard NB TH	4	4	5	4	-1	6	10	7	7	7	0	15
Land Boulevard NB TH	2	3	2	2	0	3	3	3	3	3	0	11
Land Boulevard SB TH	11	11	11	11	0	12	5	5	5	6	1	8
Land Boulevard SB TH	10	12	11	11	0	12	6	6	6	7	1	8
Land Boulevard SB RT	6	7	7	7	0	7	1	1	1	1	0	1
Binney Street at First Street:												
Binney Street EB LT	2	1	2	3	1	4	2	1	1	2	1	6
Binney Street EB TH	2	2	2	2	0	3	3	2	2	2	0	8
Binney Street EB TH/RT	2	2	3	3	0	3	3	2	3	3	0	4
Binney Street WB LT/TH	1	5	5	5	0	5	1	2	2	2	0	3
Binney Street WB TH/RT	5	5	5	5	0	5	1	2	2	2	0	4
First Street NB LT/TH/RT	4	3	3	3	0	4	1	2	2	2	0	4
First Street SB LT/TH	4	4	4	5	1	5	7	9	10	11	1	12
First Street SB RT	2	2	2	2	0	3	2	3	3	3	0	4
Binney Street at Second Street:												
Binney Street EB LT	1	1	1	1	0	2	3	2	2	2	0	6
Binney Street EB TH/RT	4	5	5	6	1	8	3	4	4	5	1	17
Binney Street WB LT	2	2	2	2	0	3	1	1	1	1	0	1
Binney Street WB TH	6	6	6	6	0	7	3	4	4	4	0	4
Binney Street WB TH/RT	6	6	6	6	0	6	4	4	4	4	0	4
Second Street NB LT/TH/RT	--	2	2	2	0	2	--	6	6	7	1	8
Second Street NB LT/TH	8	--	--	--	--	--	6	--	--	--	--	--
Second Street NB RT	2	--	--	--	--	--	1	--	--	--	--	--
Second Street SB LT/TH/RT	4	4	5	5	0	5	3	4	3	3	0	6

⁸See notes at end of table.

Table 7 (Continued)
QUEUE ANALYSIS RESULTS^A

Intersection/Lane	Weekday Morning Peak Hour						Weekday Evening Peak Hour					
	2018/2019 Observed	2020 Existing Calculated	2020 Modified Baseline Calculated	2020 Build Calculated	Increase	2025 Future Calculated	2018/2019 Observed	2020 Existing Calculated	2020 Modified Baseline Calculated	2020 Build Calculated	Increase	2025 Future Calculated
<i>Binney Street at Third Street:</i>												
Binney Street EB LT	2	2	2	2	0	3	6	7	7	7	0	8
Binney Street EB TH	3	3	4	4	0	5	3	7	6	9	3	38
Binney Street EB TH/RT	3	3	3	3	0	4	4	4	4	7	3	35
Binney Street WB LT	4	5	4	5	1	6	2	2	2	2	0	2
Binney Street WB TH	4	5	5	4	-1	5	2	3	3	3	0	3
Binney Street WB TH/RT	4	5	5	5	0	5	3	4	4	4	0	4
Third Street NB LT/TH	3	3	3	4	1	7	6	5	5	5	0	6
Third Street NB RT	1	1	2	2	0	30	1	2	3	3	0	21
Third Street SB LT/TH/RT	9	8	8	8	0	13	6	5	5	5	0	12
<i>Broadway at Third Street:</i>												
Broadway EB LT	3	4	4	4	0	8	4	4	5	5	0	8
Broadway EB TH	3	3	4	3	-1	8	5	6	6	6	0	8
Broadway EB TH/RT	2	1	1	1	0	1	3	3	3	3	0	4
Broadway WB TH/RT	3	--	--	--	--	--	5	--	--	--	--	--
Broadway WB TH	--	8	8	8	0	16	--	5	5	5	0	7
Broadway WB RT	--	4	4	5	1	15	--	2	2	2	0	3
Third Street SB LT/TH	5	6	6	6	0	13	6	5	6	5	-1	6
Third Street SB RT	2	3	3	3	0	5	1	1	2	1	-1	2

^aAll queues calculated using SimTraffic methodology. Queue in vehicles per lane.

8.0 RESIDENTIAL STREET VOLUME ANALYSIS

The Project is located in an area of both residential and commercial/retail uses. Residential streets will be subject to some measure of traffic to and from the Project. These locations and the indicators for the increases in traffic on residential streets are summarized in Table 8.

Table 8
TRAFFIC ON RESIDENTIAL STREETS

Roadway	Peak Period	Reviewed Segment	Amount of Residential	Modified Existing Two-Way Traffic	Increase due to Project
Charles Street	Morning Peak Hour	Second Street to First Street	<1/3	107	13
	Evening Peak Hour	Second Street to First Street	<1/3	228	1
Third Street	Morning Peak Hour	O'Brien Highway to Cambridge Street	>1/3 but <1/2	856	14
	Evening Peak Hour	O'Brien Highway to Cambridge Street	>1/3 but <1/2	1,217	14

9.0 PARKING ANALYSIS

9.1 INTRODUCTION

Cambridgeside currently provides parking for a number of users, including retail customers and employees, commuters and other visitors to East Cambridge. A total of approximately 2,490 parking spaces exist currently, located in a Lower Garage of 1,695 parking spaces and an Upper Garage of 795 parking spaces. The Upper Garage is accessed via two driveways to First Street. The Lower Garage is accessed via four driveways: one entrance driveway from Land Boulevard, one entrance driveway from Cambridgeside Place, one exit driveway to Cambridgeside Place, and one entrance driveway from First Street.

Under the redevelopment scenario, the Upper Garage will be removed, an entrance to the Lower Garage will be retained from First Street, and the other driveways on Land Boulevard and Cambridgeside Place will continue unchanged. All parking for the site will be accommodated in the Lower Garage.

A detailed Shared Parking Study was conducted using existing garage data identifying current retail and non-retail parking demands along with projections of future demand from the proposed land uses. The shared parking analysis, summarized in Section 9.4 below, indicates that the Lower Garage will have sufficient capacity to accommodate the future parking demands of the site, including those from the committed long-term non-tenant monthly parking spaces detailed in Section 9.2 below and the proposed Retail, Residential, and Office/R&D land uses described in Section 9.3 below.

CambridgeSide also has a Commercial Parking Facility Permit that was issued by the TP&T department and most recently amended in May of 2000. The Applicant is proposing an amendment of the Permit in connection with the Project to be consistent with the entering demands of the new mix of uses and to update several elements of the Permit that no longer apply under current conditions.

9.2 EXISTING PARKING CONDITIONS

The garages on-site currently experience a peak utilization that is approximately half of total capacity. In fact, the traffic counts conducted by CambridgeSide indicate fewer visitors come to the mall every year, as evidenced by the negative year over year trend in transient vehicle traffic shown in Table 9.1.

Table 9.1
TRANSIENT YEAR OVER YEAR TREND^a

Year	Car Counts ^b	Decline vs Prior Year, percent
2008	1,194,374	-7.5
2009	1,134,049	-5.1
2010	1,121,192	-1.1
2011	1,061,906	-5.3
2012	1,019,108	-4.0
2013	971,178	-4.7
2014	965,786	-0.6
2015	961,288	-0.5
2016	933,611	-2.9
2017	841,798	-9.8
2018	733,288	-12.9
2019	569,177	-22.4

^aSource: Cambridgeside garage counts.

^bTransient vehicles only. Monthly users not included.

In addition to short-term transient users that are primarily visitors to the retail space, CambridgeSide has agreements with certain nearby users to provide parking spaces on a monthly basis. The total monthly parkers include employees of tenant companies, non-tenant employees of nearby companies, and parking temporarily displaced by construction and/or temporary contractor parking. There are three existing long-term lease arrangements with the Royal Sonesta hotel, the Hotel Marlowe, and the former Lotus building. These three parking leases collectively account for 362 committed long-term non-tenant monthly parking spaces, with the two hotels accounting for 294 spaces. These leases along with available usage information are identified in Table 9.2 below, as requested in the Scoping Letter. These leases are expected to continue until their respective Expiration Dates.

Table 9.2
LONG-TERM PARKING LEASE DETAILS

Entity	Parking Spaces	Expiration Date	Current Utilization (percent)
Royal Sonesta	150	12/2085	23 ^a
Hotel Marlowe	144	12/2099	49 ^a
<u>PegaSystems (formerly Lotus)</u>	<u>68</u>	<u>6/2094</u>	<u>100</u>
TOTAL	362	--	--

^aSonesta and Marlowe spaces are not tracked; utilization estimated based on CambridgeSide parking reports from 2017 and 2019.

We have conservatively assumed that none of these 362 committed spaces would be made available for other users, although anecdotal data indicates that these spaces are rarely fully utilized (note

that the hotel spaces are not formally tracked by the Garage). Tracking of these spaces would have required manual counts which was not able to be conducted since the dates of data collection had already passed. The lease language for these long-term lease holders precludes the use of the 362 spaces referred to as “committed spaces” for any entity other than their identified users.

Initial parking information was collected in 2018, consisting of parking counts of the garage facilities (Upper and Lower Garages) from May, August, and December. These times represent periods where shopping center traffic is typically higher than average, based on ITE data³. The ITE data indicates May and August represent 105 and 102 percent of average month volumes respectively, and December represents 142 percent of average month volumes. Use of data from these months therefore represents a much higher than average analysis condition and provides a conservative analysis scenario. The May data also is significant as it was consistent with initial driveway and intersection counts conducted for the Project. This data showed varying levels of utilization of the garage facilities with an average maximum occupancy of 52 percent.

As requested in the Scoping Letter from TP&T, updated parking information was collected for three time periods in 2019: March, October, and December. These times were chosen as the March data was consistent with the date of supplemental intersection counts taken for the Project; October data was consistent with the TDM Monitoring Report counts conducted for the Project; and the last Thursday prior to Christmas was chosen as this is typically the highest non-weekend traffic day for shopping centers.

The parking data consisted of counts of entering and exiting volumes by hour which were then used with an initial parked car count to identify accumulations of vehicles parked for each hour. Based on these totals, counts of the existing demand for the 24-hour periods on March 6, 2019, October 3, 2019, and December 19, 2019 were developed. This data indicated there is significant excess capacity in the garages as the parking capacity at CambridgeSide far exceeds existing parking demands. This is shown in Table 9.3 below.

**Table 9.3
EXISTING PARKING UTILIZATION^a**

Time Period	Maximum Parking Utilization (spaces)	Maximum Parking Utilization ^b (Percent)	Unused Parking Spaces
March 6, 2019	1,022	41	1,468
October 3, 2019	1,136	46	1,354
December 19, 2019	1,152	46	1,338
Average	1,103	44	1,387

^aBased on garage data provided by CambridgeSide.

^bBased on 2,490 total spaces. Maximum demand observed at 12pm-1pm.

This data is also demonstrated graphically in hour-by-hour charts of the existing parking demands shown in Figure 9.a.1 for the March data, Figure 9.a.2 for the October data and Figure 9.a.3 for the December data.

³ Table 3: Monthly Variation in Shopping Center Traffic; LUC 820 Shopping Center; *Trip Generation Manual, 9th Edition*; ITE; Washington, D.C.; 2012.

9.3 FUTURE PARKING CONDITIONS

The Project involves several changes to the existing conditions at the site from a parking perspective:

- Removal of the Upper Garage
- Reduction of non-tenant monthly parking agreements (excluding the 362 committed long-term non-tenant monthly parking spaces)
- Reduction in retail parking demand due to reduced retail presence

The parking utilization shown in Figure 9.a.1 through Figure 9.a.3 indicates excess supply for the site based on the existing uses.

The nature of the parking demand at the site will also shift due to the Project components shifting from retail-based to commercial- and residential-based demands. Accordingly, parking demand rates were developed for the resized retail space and the new office, R&D, and residential components of the Project. These demands were then assembled against the backdrop of the development's parking supply completely contained within the Lower Garage.

Non-Tenant Monthly Parking Demand

Other than the 362 committed long-term non-tenant monthly parking spaces detailed in Section 9.2 above, the practice of providing parking for non-tenant monthly parkers will be phased out as the Project progresses, allowing for the Lower Garage to support the site's parking demand. A condition where all the Project parking demand and the current level of non-tenant monthly parkers are parking in the garage at the same time will not occur. The non-tenant monthly parkers will be discontinued as the Project parking demand increases and the Upper Garage is removed. Based on CambridgeSide garage parking data, reductions in the number of non-tenant monthly parkers could make available up to 630 parking spaces for the Project.

Retail Parking Demand

For the Retail component, estimates of parking demand were developed based on discussion with TP&T and a review of existing retail demand at the site. Counts had indicated a parking rate approaching 1.25 spaces per 1,000 sf, which was likely high due to the presence of the anchor stores as destination-type retail. However, with the redevelopment of these stores, it is expected there will be a reduced need for retail parking use; therefore a 0.7 space per 1,000 sf parking ratio for the retail uses is expected. This is much lower than the 5.0 spaces per 1,000 sf maximum parking ratio as identified within the PUD-8 Zoning Ordinance. No minimum parking requirements for retail exist within the PUD-8 Zoning Ordinance.

Commercial Parking Demand

For the Office/R&D components, estimates of parking demand were developed using the rates identified in the PUD-8 District zoning ordinance. These include a parking ratio of 0.9 parking spaces per 1,000 sf for office space and a parking ratio of 0.8 parking spaces per 1,000 sf for R&D space. As with the retail parking rates, no minimum parking requirements exist within the PUD-8 Zoning Ordinance.

Residential Parking Demand

The PUD-8 zoning ordinance identifies a maximum rate of 1.0 parking spaces per unit, again with no minimum requirements. However, there are local precedents for low residential supply rates in the East Cambridge area, with developments such as 159 First Street (Axiom) across from the Project initially approved with a supply rate of 0.75 spaces per unit, reduced by an amendment to the Special Permit decision to 0.56 spaces per unit. The K2C2 study included a recommended minimum parking rate of 0.5 spaces per unit with a maximum of 0.75 spaces per 1,000 sf in the Kendall Square and Central Square areas. Recently, the Ames Street Residences 280-unit project was approved with effectively no parking. Based on these projects and in an effort to minimize car ownership in the East Cambridge area, the Project is proposing a residential supply rate of 0.75 spaces per unit.

These revised land use sizes along with the proposed parking ratios resulted in the parking demand totals that are shown in Table 9.4, along with minimum, maximum, expected, and shared parking totals for the project.

**Table 9.4
PROPOSED PROJECT PARKING**

Non-Residential Use	GSF, ksf	Minimum ^a		Maximum ^b		Expected ^c		Total Spaces	Notes
		Ratio	Spaces	Ratio	Spaces	Ratio	Spaces		
Office	415	0	0	0.9	374	0.9	374		Office tenants to be parked at a rate up to 0.9 sp/ksf
Lab	685	0	0	0.8	548	0.8	548		R&D tenants to be parked at a rate up to 0.8 sp/ksf
Retail	390	0	0	5	1950	0.7	273		Retail tenants to be parked at a rate up to 0.7 sp/ksf, shared parking after 5pm
Total Commercial	1490		0		2872		1195	1195	spaces reserved for commercial use between 7am and 5pm, based on Shared Parking
Property Employees							54	60	up to 60 spaces reserved for property employee use between 7am and 5pm
	units	Ratio	Spaces	Ratio	Spaces	Ratio	Spaces		
Residential	200	0	0	1	200	0.75	150	75	spaces reserved for residential use between the hours of 7am and 5pm, based on Shared Parking
(Res GSF, ksf)	175								
Total Project Parking Demand	1665		0		3072		1399	1,330	
Total, Committed Spaces							362	1,692	
Total Physical Spaces								1,695	
Leftover Spaces for Other Uses								3	

^aMinimum ratios are zero for all land uses as identified in PUD-8 zoning.

^bMaximum ratios as identified in PUD-8 zoning.

^cExpected use ratios given elimination of anchor stores and less destination retail, consistent with overall downward trends in retail parking demand at CambridgeSide.

Table 9.4 identifies a parking demand and initial steps to provide a parking management plan, with anticipated parking levels available for commercial uses and minimum parking levels available for residential use. Additional details related to shared parking in the garage and variation based on seasonal factors are provided in Section 9.4.

9.4 SHARED PARKING ANALYSIS

Rather than provide a static total of demand versus supply, a review of Future Project Parking Conditions across a 24-hour period for each of the three days in March, October, and December was calculated. Data from the Urban Land Institute publication Shared Parking⁴ was used. In this manner, parking demands across the entire 24-hour period can be calculated. The results of the analyses are provided below in Table 9.5 and graphically depicted in Figure 9.c.1 for the March condition, Figure 9.c.2 for the October condition, and in Figure 9.c.3 for the December condition. Such analyses also satisfy the requirement of the PUD-8 District Zoning for a Shared Parking Study, as set forth in Section 13.106.5 of the Ordinance. Seasonality has also been accounted for with seasonal corrections of 7 percent and 45 percent made to the respective October and December retail patrons parking demand based on the garage data.

Table 9.5
FUTURE PROJECT PARKING UTILIZATION^a

Time Period	Maximum Parking Utilization (spaces)	Maximum Parking Utilization ^b (Percent)	Unused Parking Spaces
March	1,252	93.9	81
October	1,275	95.6	58
December	1,323	99.2	10
Average	1,283	96.2	50

^aBased on garage data provided by CambridgeSide.

^bBased on 1,333 total spaces. Maximum demand observed at 1pm-2pm.

As shown in Table 9.5 and Figure 9.c.1, Figure 9.c.2, and Figure 9.c.3, during the peak parking demand from 1:00 PM to 2:00 PM, between 10 and 81 spaces are available within the garage during each of these time periods. Accordingly, sufficient parking supply will exist in the Lower Garage to accommodate the demands of new and existing uses. The Garage Operations team will continue to ensure that adequate parking supply is available to meet demands throughout construction and operation, as it has for the last 30 years.

It is also important to note that traffic and parking counts of CambridgeSide have decreased continually over the last 10 years. This trend is expected to continue with the closure of Sears and impending closure of Macy's and the continued pressure on retail locations due to online sales. In addition, the increasing use of ridesharing services including Uber/Lyft and Personal Mobility Devices (PMDs) such as shared scooters and shared bicycles also has the effect of reducing parking demands. As forecasted by market and transportation authorities, these trends are only expected to accelerate, so there is expected to be less demand for parking spaces in the future.

⁴ *Shared Parking, 3rd Edition*; Urban Land Institute; Washington, D.C.; 2020.

The Lower Garage is currently a self-park facility. Pursuant to Section 13.106.2 of the PUD-8 zoning, the Planning Board may approve a managed parking plan. The special permit application will seek approval from the Planning Board of managed parking in the Lower Garage, as necessary. CambridgeSide anticipates seeking administrative approval of any such managed parking plan from TP&T prior to implementation of the same.

The addition of managed parking to the Lower Garage has been discussed with the garage operator, and the potential for up to 300 spaces could be added in peak time periods. Based on these additional conditions along with the data to date, the Lower Garage is expected to be able to meet the demands of all users contemplated under this development scenario.

9.5 BICYCLE PARKING

The bicycle parking requirements for the Project were reviewed per the City of Cambridge Zoning Ordinance 6.100 using the PUD-8 District-approved Development Program. As identified in Section 6.103.1 the bicycle parking requirement shall apply to the following types of projects:

- a) The construction of a new building or establishment of a new open-air use on a lot.
- b) An increase of at least fifteen percent (15%) in the number of residential dwelling units on a lot or in the amount of non-residential Gross Floor Area on a lot from the time of adoption of Section 6.100.
- c) The conversion of existing Gross Floor Area to a new category of non-residential use, where such conversion results in at least a fifteen percent (15%) increase in the total number of bicycle parking spaces that would be required for the entire building by Section 6.100.

Based upon an analysis by the Project Site Engineer TetraTech, the required bicycle parking for the Project per building has been calculated as shown in Table 9.6:

**Table 9.6
BICYCLE PARKING ANALYSIS^a**

<u>Building</u>	<u>New GFA for Buildings (sf)</u>	<u>Project Type</u>	<u>Long Term Spaces</u>	<u>Short Term Spaces</u>	<u>Total Spaces</u>
Sears	86,000	a	31	7	38
Upper Garage	310,000	a	239	35	274
Best Buy	335,000	a	73	34	107
Macy's	230,000	a	61	14	75
TOTAL			404	90	494

^aSource: TetraTech and City of Cambridge Zoning Ordinance Article 6 – Off Street Parking and Loading Requirements and Nighttime Curfew on Large Commercial Though Trucks.

These totals are based upon Section 6.103.1 triggers for projects types (a) and (c) and Section 6.107 for the required quantities of bicycle parking and the incremental changes in Gross Floor Area (GFA) proposed with the new buildings. This zoning accounts for bicycle parking based on the construction of a new building as well as based on conversion of existing Gross Floor Area. Calculations supporting these totals are provided in the Appendix.

The Project will provide approximately 494 bicycle spaces for use by employees and residents. Approximately 404 of these spaces will be provided within the building space for secure, weather-protected bicycle parking and the other 90 spaces will be located around the site for short-term bicycle parking. A general plan depicting the proposed bicycle access and storage for the Project is shown in Figure 9.d.1. Other detailed plans depicting the long-term bicycle parking for the various buildings are shown in Figures 9.d.2 through 9.d.5. Routes identifying how these spaces are accessed are also noted on Figure 9.d.1 and the individual bike parking figures.

9.6 COMMERCIAL PARKING FACILITY PERMIT MODIFICATIONS

The initial 1987 Planning Board Special Permit for CambridgeSide contained a number of commitments towards minimizing vehicle trips to the site. In 1990, a Commercial Parking Facility Permit (CPP) was issued with restrictions on operations, including a 10:00 AM opening time, exclusive reservation of spaces for the Sonesta Hotel and maximum usage of spaces for certain users (e.g., mall employees). Over time the CPP has evolved through amendments, the latest of which was issued in 2000 (included in the Technical Appendix), to include additional commitments such as providing exclusive parking spaces for the nearby Hotel Marlowe. Currently the limit on the number of spaces that are available before 10:00 AM is 536 spaces. Additional restrictions and conditions are summarized below, with the full set of restrictions and conditions identified on the attached 2000 amendment to the CPP:

- Of the 536 spaces available (exclusive of reserved hotel spaces) before 10am:
 - Up to 250 spaces available to Cambridge employees at market rate (over \$150/mo.)
 - 100 spaces available to courthouse employees at discounted rate (33% below market rate). List to be submitted annually to TP&T
 - 33 spaces available to carpoolers at discounted rate, with annual report to TP&T
 - Up to 3 car sharing spaces at discounted rate
 - Remaining spaces for:
 - Employees of the mall
 - Patrons of breakfast establishments(Except for 150 Lotus office employees, these remaining space users will not be eligible for discounted parking)
 - Additional use before 10am Monday-Friday allowed for:
 - New or renovated nearby buildings employee parking requirements
 - Existing off-street spaces that are permanently eliminated elsewhere
 - Parking temporarily displaced by construction or repair, with prior approval from TP&T
 - Temporary construction personnel parking, with prior approval from TP&T
 - Residential snow emergency parking

There are also commitments to various TDM measures that were to be implemented for continued operation of CambridgeSide in the early 2000s. These measures were also included in an associated special permit amendment for CambridgeSide and include the following:

- Fee structure to discourage long-term parking, except with respect to the uses identified above.
- Sell MBTA passes in mall, and provide annual report to TP&T.
- 50% transit subsidy to mall employees.
- Pro-transit advertising
- Guaranteed ride home

- Ridesharing program
- Reserved carpool and vanpool parking
- Join CRTMA
- North Station shuttle contributions
- 33 bike spaces & bike station study
- On-street inventory to TP&T
- TP&T may inspect with notice
- Annual report with compliance and peak accumulation (average month and peak holiday)

CambridgeSide currently participates in the TDM measures noted above, except for selling MBTA passes on site, due to limitations imposed by the MBTA with regard to a new retail sales system. The Project will continue the current TDM measures and supplement the same to mitigate any potential impacts of the Project.

With respect to the parking conditions identified above, the changes in use associated with the Project result in a need to eliminate the restriction on the number of spaces that can be made available before 10:00 AM – for example, office and laboratory employees at the Project will need to report to work earlier in the morning. The projected parking demands shown in Figure 9.c.1, Figure 9.c.2, and Figure 9.c.3 indicate that over 1,100 spaces will be required in all time periods prior to 10:00 AM. With the increasing availability of transportation connections in the area, it is anticipated that parking demand in East Cambridge will decline. Given the extensive future transit improvements on the Red and Green Lines, and as shown in this TIS, removing this restriction will not substantially impact anticipated traffic flows in the surrounding area. The Project will continue to accommodate the reserved hotel spaces, which are captured in the 362 committed long-term non-tenant monthly parking spaces addressed throughout this TIS.

In light of the above-described changed circumstances, among others, an amendment to the CPP is proposed.

Table 9.7 provides recommendations for an amendment to the CPP, to be reviewed with the TP&T Department, that would supersede the current amended CPP. The Project will seek the approval of the Director of the TP&T Department for the proposed modifications to the Permit and the Applicant will continue to coordinate with TP&T to effectuate such an amendment to the CPP.

Table 9.7
PROPOSED COMMERCIAL PARKING FACILITY PERMIT REVISIONS

Measure	Proposed Changes	Reason for Change
CPP Condition 1* (Shuttle Bus System)	<ul style="list-style-type: none"> - Expand service, either through additional buses or expansion of EZRide shuttle bus service to satisfy requirements - Maintain and expand service to begin at 6:00 AM and extend to Lechmere Station - Provide two buses during peak hours from 6:00 AM to 9:30 AM and from 3:30 PM to 6:00 PM - Provide for 10-minute frequency 	<ul style="list-style-type: none"> - Provides expanded hours to capture weekday morning peak hour of commuting - Provides additional capacity to accommodate increased demand from new tenants
CPP Conditions 3 and 4 (Reserved Spaces for Sonesta Hotel and Hotel Marlowe)	<ul style="list-style-type: none"> - None 	<ul style="list-style-type: none"> - N/A
CPP Condition 2 (Opening Time of 10:00 AM)	<ul style="list-style-type: none"> - Remove restrictions on garage opening time 	<ul style="list-style-type: none"> - Opening Time of 10:00 AM was appropriate for retail facilities; however, proposed land uses (e.g., office and laboratory) have earlier opening times - Residential tenants will need the ability to access the parking facility at all times - Parking demands in the neighborhood are expected to continue declining in light of wide-scale transit improvements, such that removing this restriction will not adversely impact the traffic network

**Table 9.7
PROPOSED COMMERCIAL PARKING FACILITY PERMIT REVISIONS
(CONTINUED)**

Measure	Proposed Changes	Reason for Change
CPP Condition 5 (536-space limit prior to 10:00 AM, and associated provisions)	<ul style="list-style-type: none"> - Remove restrictions on garage opening time and associated provisions regarding use prior to such allowed 10 AM opening time 	<ul style="list-style-type: none"> - The proposed parking demand for the Project’s mix of land uses (e.g., office, laboratory, residential) is expected to exceed 536-space limit prior to 10:00 AM due to differing business hours from the former retail-only land use, as well as the residential tenants’ need to be able to freely come and go from their place of residence - Parking demands in the neighborhood are expected to continue declining in light of wide-scale transit improvements, such that removing this restriction on parking at the site before 10:00 AM will not adversely impact the traffic network - Given the proposal that the 536-space restriction be removed entirely due to changed circumstances, the associated provisions regarding specific users of such spaces are no longer applicable
CPP Condition 6 (Charge market rates to discourage long-term parking)	<ul style="list-style-type: none"> - None, except to update the current Fee Schedule 	<ul style="list-style-type: none"> - N/A
CPP Conditions 7-13 (TDM measures)	<ul style="list-style-type: none"> - Retain these existing TDM measures - Clarify the TDM measures already satisfied (e.g., one-time contributions; parking space inventories) - Add the supplemental TDM measures identified in Section 14.0 of this TIS 	<ul style="list-style-type: none"> - Update to capture the additional TDM measures proposed in connection with the Project (see Section 14.0 of this TIS) and to clarify the status of existing TDM measures/contributions

* References included in Table 9.6 are to Conditions of the 2000 amendment to the CPP, which is attached to this TIS.

9.7 PARKING OPERATIONS

The CambridgeSide Garage Operations Department has been successfully managing garage operations since the CPP was first implemented. There are three existing long-term lease arrangements, which the Garage Operations team has been honoring for over 30 years. These include the arrangements with the Royal Sonesta and Hotel Marlowe as well as the former Lotus building leases. However, these are the only long-term leases in place.

Data on usage for these long-term committed non-tenant monthly parking spaces is not tracked by the garage, therefore utilization is estimated. In most cases the vehicles associated with the hotels are parked by attendants to improve efficiency. The PegaSystems lease is estimated at 100 percent utilization as over 68 spaces attributable to the Pega company are indicated as occupied in the parking reports generated by the Garage Operations Team.

Parking Fees

The Garage Operations team at CambridgeSide will continue to manage the parking facility. In keeping with the provisions of the CPP and standard TDM practice, CambridgeSide will continue their practice of charging market rates for parking with the new uses and “unbundling” parking charges from housing costs for the residential units.

10.0 TRANSIT ANALYSIS

10.1 PROJECT TRANSIT DISTRIBUTION

An analysis of transit usage was conducted to determine impacts that might be recognized under Build conditions. There are a total of four bus routes and two subway lines that are available for employees and residents at the Site. The distribution on the transit routes is shown in Table 10.1.

**Table 10.1
TRANSIT SYSTEM TRIP DISTRIBUTION**

Time Period/Directional Distribution	Project Transit Trips ^a	Green Line Distribution ^b	Red Line /CambridgeSide Shuttle Bus Distribution ^c	Lechmere Bus Distribution ^d
<i>Weekday Daily:</i>				
Entering	1,608	1,158	289	161
<u>Exiting</u>	<u>1,608</u>	<u>1,158</u>	<u>289</u>	<u>161</u>
Total	3,216	2,316	578	322
Peak Hour Headways (Minutes)	--	6	4.5	8-30
<i>Weekday Morning:</i>				
Entering	364	262	66	36
<u>Exiting</u>	<u>30</u>	<u>22</u>	<u>5</u>	<u>3</u>
Total	394	284	71	39
<i>Weekday Evening:</i>				
Entering	44	32	8	4
<u>Exiting</u>	<u>332</u>	<u>239</u>	<u>60</u>	<u>33</u>
Total	376	271	68	37

^aIncludes 58 percent of monthly parkers redistributed to transit.

^b72 percent assignment.

^c18 percent assignment. Total of subway assignment = 90 percent.

^d10 percent assignment, distributed among all 4 bus routes.

It should be noted that the trip distribution in Table 10.1 includes not only the new Project trips expected to be made via transit, but also a portion of the trips due to non-site monthly parkers that are expected to utilize alternative transportation when the long-term parking changes go into effect at the site. These users may turn to remote working, bicycling, or other methods; however, to account for a potential switch to transit, all of these trips were assigned to the transit services as if they were new trips to the system.

The peak-hour headways listed in Table 10.1 indicate approximately ten trains arrive/depart the Lechmere Square station during the peak hours. The peak-hour directional passenger loading from the proposed project of 31 to 211 peak-hour person trips directed towards the Green Line can be accommodated without a noticeable increase in operating characteristics. Detailed analysis of transit ridership impacts due to the project is provided in Table 10.2 for the Green Line subway loadings, Table 10.3 for the Red Line subway loadings, and Table 10.4 for the bus loadings, respectively. Relevant capacity information was obtained from the MBTA for the Green Line, Red Line, and Bus Routes 69, 80, 87, and 88.

**Table 10.2
MBTA GREEN LINE SUBWAY PEAK HOUR RIDERSHIP IMPACTS**

Train Line	Time Period	Existing						Future						Proposed with Project		Ridership Increase	
		No. of Trains ^a	No. of Cars per Train	Max. Load per Car ^b	Hourly Capacity ^c	Ridership ^d	V/C ^e	No. of Trains ^f	No. of Cars per Train	Max. Load per Car	Hourly Capacity	Ridership ^g	V/C	Ridership	V/C	Percent	V/C
Green Line	Morning Peak Hour	10	2	110	2,200	1,192	0.54	12	2	110	2,640	1,431	0.54	1,715	0.65	19.8	0.11
	Evening Peak Hour	10	2	110	2,200	1,291	0.59	12	2	110	2,640	1,550	0.59	1,821	0.69	17.5	0.10

^aBased on scheduled rush-hour headway values of 6 minutes.

^bDefined on the basis of MBTA design standards.

^cBased on standard passenger load per car, number of cars per trains, and number of trains per hour.

^dFrom MBTA ridership count results

^eVolume-to-capacity ratio.

^fBased on future scheduled rush-hour headway values of 5 minutes.

^gIncreased proportionally to the increase in capacity.

**Table 10.3
MBTA RED LINE SUBWAY PEAK HOUR RIDERSHIP IMPACTS**

Train Line	Time Period	Directional Flow	Existing						Future						Proposed with Project		Ridership Increase	
			No. of Trains ^a	No. of Cars per Train	Max. Load per Car ^b	Hourly Capacity ^c	Line Flow ^d	V/C ^e	No. of Trains ^f	No. of Cars per Train	Max. Load per Car	Hourly Capacity	Line Flow ^g	V/C	Line Flow	V/C	Percent	V/C
Red Line	Morning Peak Hour	Outbound	13	6	167	13,026	2,903	0.22	20	6	167	20,040	4,467	0.22	4,486	0.22	0.4	0.00
		Inbound	13	6	167	13,026	7,823	0.60	20	6	167	20,040	12,036	0.60	12,088	0.60	0.4	0.00
	Evening Peak Hour	Outbound	13	6	167	13,026	8,001	0.61	20	6	167	20,040	12,310	0.61	12,350	0.62	0.3	0.01
		Inbound	13	6	167	13,026	5,450	0.42	20	6	167	20,040	8,385	0.42	8,413	0.42	0.3	0.00

^aBased on average headway of 4.5 minutes over one hour.

^bDefined on the basis of MBTA design standards.

^cBased on standard passenger load per car, number of cars per trains, and number of trains per hour.

^dFrom MBTA ridership count results.

^eVolume-to-capacity ratio.

^fBased on average headway of 3 minutes over one hour.

^gIncreased proportionally to the increase in capacity.

Table 10.4
MBTA BUS ROUTE PEAK HOUR RIDERSHIP IMPACTS

<i>Weekday Morning Peak Hour:</i>									
Route No.	Route Headway ^a	Maximum Load ^b	Hourly Capacity	Existing		Proposed with Project		Ridership Increase	
				Ridership ^c	V/C ^d	Ridership	V/C	Percent	V/C
69	10 minutes	60	600 ^e	125	0.21	133	0.22	6.4	0.01
80	20 minutes	60	300 ^f	147	0.49	157	0.52	6.8	0.03
87	20 minutes	60	300 ^g	128	0.43	137	0.46	7.0	0.03
88	15 minutes	60	420 ^h	183	0.44	195	0.46	6.6	0.02

<i>Weekday Evening Peak Hour:</i>									
Route No.	Route Headway ^a	Maximum Load ^b	Hourly Capacity	Existing		Proposed with Project		Ridership Increase	
				Ridership ^c	V/C ^d	Ridership	V/C	Percent	V/C
69	20 minutes	60	360 ⁱ	108	0.30	115	0.32	6.5	0.02
80	20 minutes	60	360 ⁱ	123	0.34	132	0.37	7.3	0.03
87	20 minutes	60	360 ⁱ	133	0.37	142	0.39	6.8	0.02
88	20 minutes	60	360 ⁱ	174	0.48	186	0.52	6.9	0.04

^aBased on current MBTA schedule.

^bDefined on the basis of MBTA design standards.

^cBased on MBTA Ridership Data for composite year 2018.

^dVolume-to-capacity ratio.

^eCapacity calculated based on 6 inbound buses and 4 outbound buses in the peak hour.

^fCapacity calculated based on 3 inbound buses and 2 outbound buses in the peak hour.

^gCapacity calculated based on 3 inbound buses and 2 outbound buses in the peak hour.

^hCapacity calculated based on 4 inbound buses and 3 outbound buses in the peak hour.

ⁱCapacity calculated based on 3 inbound buses and 3 outbound buses in the peak hour.

10.2 SUMMARY OF ANALYSIS RESULTS

Tables 10.2 through 10.4 demonstrate that sufficient capacity exists on the bus routes and subway lines to accommodate the expected ridership increases due to the Project, including new riders from a potential switch of non-site monthly parkers to transit. Increases in volume-to-capacity (v/c) ratios pertaining to line volume are between 0.0 and 0.11 for all affected bus routes, the Green Line, and the Red Line subway systems.

Seating and lighted shelters are available at the Lechmere Square and Kendall Square stations. No benches or shelters are provided for at any other locations along the other bus routes in proximity to the Site.

10.3 FUTURE PUBLIC TRANSIT CONDITIONS

Several future transit and pedestrian/bicycle facilities are proposed or under construction in the Project vicinity. These are shown on Figure 10.a.1.

Green Line

The MBTA is in the process of introducing 24 new cars on the Green Line as part of its broader Green Line expansion project. The cars will be able to accommodate a 10 percent increase in passengers as compared with the existing cars. The MBTA is also considering a larger upgrade in trolley cars that would potentially double the Green Line capacity; however, this upgrade is not funded.

The GLX project is an extension of the Green Line service out to Medford using existing MBTA Commuter Rail rights-of-way. Five new stations will be built in Somerville with the last at College Avenue built near Tufts University in Medford. Service is expected to see an increase of 30,700 boardings with a total weekday ridership of 52,000 riders.

Red Line

The MBTA is also in the process of replacing the cars on the Red Line, with plans to replace all cars by 2023. This is expected to increase overall capacity by 50 percent by raising the current number of trains per hour from 13 to 20 and allowing a three-minute headway for trains, which is a reduction from the current four-and-a-half minute headway. It should be noted that the ridership data from the MBTA are based on aggregated counts from Fall of 2017 and from the entire year of 2019 which may not reflect peak train ridership occurring during one or two specific hours of one day.

Proposed Transit Services

Additional transit improvements were identified in the Kendall Square Mobility Task Force Report⁵. These include the potential for bus priority lanes on First Street, Binney Street, and Third Street, as well as the possible implementation of a new CT4 bus. This would connect Sullivan Square and Kenmore Square via Lechmere and Kendall Square through the Inner Belt Road proposed through Cambridge Crossing. These are noted as potential options, as MBTA has stated that no funding has been identified for the CT4 bus and the Report notes that more work is needed to understand the impacts of the bus priority lanes.

Also contained in the KSMTF were the improvements of a Lechmere-Kendall Shuttle bus as well as expanded EZRide shuttle bus service. The Lechmere-Kendall Shuttle would be a peak hour service operating from 6:30 to 9:00 AM and from 3:30 to 6:00 PM on approximately 15 minute frequencies. The expansion to the EZRide includes measures to decrease peak-period headway from the current 7 minutes to 4 minutes. The report notes that a reduction in travel time is likely through transit priority treatments on First Street and Binney Street.

Proposed Grand Junction Rail with Trail

Future rail service noted in the KSMTF Report may include the establishment of the Grand Junction Rail with a Trail design, a proposed multi-use path serving pedestrians and bicyclists alongside a future rail transit corridor. The Grand Junction section refers to a railroad right of way (ROW)

⁵ *Kendall Square Mobility Task Force Final Report*; City of Cambridge; Cambridge, MA; 2017.

between the Boston University Bridge to where the rail meets the Somerville border past Cambridge Street. The rail is currently used for MBTA commuter rail and some Amtrak ‘equipment moves’ between North and South Station. This is a vital link between the north and south ‘sides’ of MBTA commuter and Amtrak services, indicating service will have to be retained. A portion of the multi-use path has been constructed between Main Street and Broadway with an additional portion of the path funded at \$10M for the segment between Broadway and Cambridge Street. The path is not funded south of Main Street. There has also been study of Bus Rapid Transit (BRT) and rail service on the ROW, with extensions to Sullivan Square to the north and to Longwood Medical Area to the south. As noted in the Technical Report: Grand Junction Feasibility Review⁶ there are technical and monetary funding challenges to provide connections to other transit systems.

Should the multi-use path become constructed and/or rail service be available, visitors to the Project site would be able to utilize this facility, located less than one mile from the site. Some of the other services such as the CT4 bus, the Lechmere-Kendall Shuttle, and the EZRide shuttle would utilize First Street and as such will pass adjacent to the Project site. Funding for these items is also unclear, as discussed above and further below with respect to the EZRide shuttle.

10.4 ORANGE LINE PROJECT IMPACTS

The Sullivan Square Station is approximately a 1.6 mile walk (approximately 33 minutes) from Cambridgeside Place. None of the four MBTA bus routes from Lechmere Station run directly to Sullivan Station. There are 12 MBTA bus routes that stop at Sullivan Station and of them, only three intersect bus routes that travel to Lechmere Station. Walking may be required to transfer between the two bus routes in order to reach Sullivan Station and the timing of the schedules of the different routes do not align very well. This makes it unlikely that patrons would use Sullivan Station to get to and from Cambridgeside Place. Future planned transit services may result in more efficient connections between the site and the Sullivan Station.

Residents and employees may walk to Community College Station which is also on the Orange Line and is an approximately 0.6 mile walk (approximately 13 minutes) from Cambridgeside Place. However, this requires walking over the Gilmore Bridge which is not a desirable route for pedestrians and only provides Orange Line service, with no buses stopping at the Community College Station. Therefore, it is likely that the impact at this station from the project will be minimal, at least until such time that future services are implemented.

10.5 FUTURE PRIVATE TRANSIT CONDITIONS

In addition to the public transit services provided by the MBTA, private transit services provided by the CRTMA EZRide shuttle bus and the CambridgeSide Shuttle Bus (CS Shuttle) are also available. The EZRide shuttle bus provides a larger coverage area than the CS Shuttle with connections to Kendall Square and North Station. However, this larger coverage area includes additional bus stops and leads to delays due to congestion particularly in Charles River Dam Road and Leverett Circle to North Station. The EZRide provides service during the weekday morning and evening commuter periods, but not during the weekday midday or weekend time periods.

The CS Shuttle travels between CambridgeSide and Kendall Square which is a relatively small area with no stops in between. However, the CS Shuttle consists of one 20-passenger bus making three

⁶ *Technical Report: Grand Junction Feasibility Review*; IBI Group; Boston, MA; December 2016.

to four round trips between these locations, with a start time of 9:00 AM and an end time of 8:00 PM, resulting in a 15- to 20-minute frequency.

To expand the CS Shuttle to provide more frequent service would likely require an additional bus and an earlier start time of 6:00 AM. This would ensure no reduction in service for the retail employees and customers that use the CS Shuttle, and would result in the capacity for up to 120 passengers per hour to use the CS Shuttle service, as calculated below:

$$2 \text{ buses @ } 20 \text{ passengers/bus} * 3 \text{ round trip loops/hour} = 120 \text{ passengers/hour}$$

This would accommodate the additional traffic expected with the Project, as between 55 and 58 additional passengers are anticipated during the weekday morning and weekday evening peak hours and the existing average ridership is zero passengers during the weekday morning peak hour and 18 passengers during the weekday evening peak hour.

The Applicant has met with the CRTMA Executive Director regarding the potential for consolidation of the EZRide service with the CambridgeSide shuttle service. There were several concerns at that time that precluded the consolidation of the services, such as funding for the EZRide and the requirement that other entities in the Kendall Square and First Street corridors would need to provide support for the expansion of EZRide to include all-day weekday service as well as weekend service. However, the Applicant has indicated their willingness to work with the CRTMA on potential consolidation of services once the CRTMA has more clarity on funding any expansion to meet CambridgeSide's and other area entity's requirements.

11.0 PEDESTRIAN ANALYSIS

A pedestrian impact analysis was conducted at the study area intersections under 2020 Existing, 2020 Modified Baseline, 2020 Build, and 2025 Future conditions, as required in the scoping letter. For signalized intersections, the pedestrian level-of-service (PLOS) calculations measure the adequacy of the pedestrian phases (exclusive or concurrent) for sufficient time to cross major or minor streets. The unsignalized analysis relies on a critical gap procedure. The analysis methodology was based on procedures outlined in the 2000 HCM for signalized and unsignalized intersections and is provided in the Appendix. Table 11.1 summarizes the results of the pedestrian analysis at the signalized intersections, while Table 11.2 presents a summary of the pedestrian analysis at the unsignalized intersections. The PLOS ratings for the intersections are shown graphically on Figure 11.a.1 and Figure 11.a.2 for the weekday morning peak hour and on Figure 11.a.3 and Figure 11.a.4 for the weekday evening peak hour. It should be noted that the delay calculated for the Cambridgeside Place mid-block crosswalk does not reflect actual conditions due to slow speeds on the street and consistent yielding of motorists to pedestrians in the crosswalk.

The Project does not change the PLOS of any of the crosswalks studied except for the Spring Street crosswalk during the weekday morning peak hour which decrease from a PLOS B to PLOS C with the addition of the Project vehicle and pedestrian traffic. The increase in delay at the Spring Street crosswalk during the weekday morning peak hour is only 2 seconds but occurs at the upper range of the PLOS B category. Delay is also added to the Cambridgeside Place mid-block crosswalk during the weekday morning peak hour and weekday evening peak hour.

Table 11.1
PEDESTRIAN LEVEL-OF-SERVICE SUMMARY – SIGNALIZED INTERSECTIONS

Intersection/Time Period/Crossing Path	2020 Existing			2020 Modified Baseline			2020 Build			Delay Increase	2025 Future		
	Demand ^a	Delay ^b	LOS ^c	Demand	Delay	LOS	Demand	Delay	LOS		Demand	Delay	LOS
<i>O'Brien Highway at Museum Way:</i>													
<i>Weekday Morning:</i>													
Crossing O'Brien Highway (East)	90	37	D	90	37	D	90	37	D	0	90	37	D
Crossing O'Brien Highway (West)	58	37	D	58	37	D	58	37	D	0	58	37	D
Crossing Museum Way (North)	35	39	D	35	39	D	35	39	D	0	35	39	D
<i>Weekday Evening:</i>													
Crossing O'Brien Highway (East)	105	32	D	105	32	D	105	32	D	0	105	32	D
Crossing O'Brien Highway (West)	45	32	D	45	32	D	45	32	D	0	45	32	D
Crossing Museum Way (North)	11	35	D	11	35	D	11	35	D	0	11	35	D
<i>O'Brien Highway at Land Boulevard/Charlestown Avenue:</i>													
<i>Weekday Morning:</i>													
Crossing O'Brien Highway (West)	95	39	D	95	39	D	95	39	D	0	95	39	D
Crossing Land Boulevard (South)	56	42	E	56	42	E	56	42	E	0	56	42	E
<i>Weekday Evening:</i>													
Crossing O'Brien Highway (West)	146	34	D	146	34	D	146	34	D	0	146	34	D
Crossing Land Boulevard (South)	92	37	D	92	37	D	92	37	D	0	92	37	D
<i>O'Brien Highway at Cambridge Street/East Street:</i>													
<i>Weekday Morning:</i>													
Crossing O'Brien Highway (East)	17	22	C	17	22	C	17	22	C	0	17	39	D
Crossing O'Brien Highway (West)	199	22	C	199	22	C	463	22	C	0	199	39	D
Crossing East Street (North)	28	22	C	28	22	C	28	22	C	0	28	38	D
<i>Weekday Evening:</i>													
Crossing O'Brien Highway (East)	30	22	C	30	22	C	30	22	C	0	30	34	D
Crossing O'Brien Highway (West)	125	22	C	125	22	C	375	22	C	0	125	34	D
Crossing East Street (North)	2	22	C	2	22	C	2	22	C	0	2	33	D

^aDemand in pedestrians per hour.

^bAverage delay per pedestrian (in seconds).

^cPedestrian Level of Service.

Table 11.1 (Continued)
PEDESTRIAN LEVEL-OF-SERVICE SUMMARY – SIGNALIZED INTERSECTIONS

Intersection/Time Period/Crossing Path	2020 Existing			2020 Modified Baseline			2020 Build			Delay Increase	2025 Future		
	Demand ^a	Delay ^b	LOS ^c	Demand	Delay	LOS	Demand	Delay	LOS		Demand	Delay	LOS
<i>O'Brien Highway at North First Street:</i>													
<i>Weekday Morning:</i>													
Crossing O'Brien Highway (West)											264	28	C
Crossing North First Street (North)											128	32	D
Intersection is Constructed under 2025 Future Conditions													
<i>Weekday Evening:</i>													
Crossing O'Brien Highway (West)											250	24	C
Crossing North First Street (North)											65	27	C
<i>Cambridge Street at First Street/Bus Station Driveway:</i>													
<i>Weekday Morning:</i>													
Crossing Cambridge Street (East)	498	26	C	534	26	C	762	26	C	0	727	39	D
Crossing Cambridge Street (West)	183	26	C	196	26	C	202	26	C	0	286	39	D
North First Street (North)	--	--	--	--	--	--	--	--	--	--	404	33	D
Crossing First Street (South)	40	26	C	53	26	C	69	26	C	0	153	36	D
<i>Weekday Evening:</i>													
Crossing Cambridge Street (East)	734	26	C	770	26	C	984	26	C	0	954	34	D
Crossing Cambridge Street (West)	264	26	C	277	26	C	275	26	C	0	354	34	D
North First Street (North)	--	--	--	--	--	--	--	--	--	--	126	28	C
Crossing First Street (South)	32	26	C	45	26	C	47	26	C	0	281	31	D
<i>O'Brien Highway at Third Street:</i>													
<i>Weekday Morning:</i>													
Crossing O'Brien Highway (East)	38	27	C	38	27	C	38	27	C	0	38	34	D
Crossing Third Street (South)	30	27	C	30	27	C	30	27	C	0	30	34	D
<i>Weekday Evening:</i>													
Crossing O'Brien Highway (East)	46	27	C	46	27	C	46	27	C	0	46	30	C
Crossing Third Street (South)	31	27	C	31	27	C	31	27	C	0	31	30	C

^aDemand in pedestrians per hour.

^bAverage delay per pedestrian (in seconds).

^cPedestrian Level of Service.

Table 11.1 (Continued)
PEDESTRIAN LEVEL-OF-SERVICE SUMMARY – SIGNALIZED INTERSECTIONS

Intersection/Time Period/Crossing Path	2020 Existing			2020 Modified Baseline			2020 Build			Delay Increase	2025 Future		
	Demand ^a	Delay ^b	LOS ^c	Demand	Delay	LOS	Demand	Delay	LOS		Demand	Delay	LOS
Cambridge Street at Third Street:													
<i>Weekday Morning:</i>													
Crossing Cambridge Street (East)	56	13	B	56	13	B	56	13	B	0	56	13	B
Crossing Cambridge Street (West)	72	13	B	72	13	B	72	13	B	0	72	13	B
Crossing Third Street (North)	224	13	B	224	13	B	243	13	B	0	243	13	B
Crossing Third Street (South)	112	13	B	112	13	B	122	13	B	0	122	13	B
<i>Weekday Evening:</i>													
Crossing Cambridge Street (East)	50	13	B	50	13	B	50	13	B	0	50	13	B
Crossing Cambridge Street (West)	28	13	B	28	13	B	28	13	B	0	28	13	B
Crossing Third Street (North)	185	13	B	185	13	B	196	13	B	0	196	13	B
Crossing Third Street (South)	71	13	B	71	13	B	75	13	B	0	75	13	B
First Street at Thorndike Street:													
<i>Weekday Morning:</i>													
Crossing Thorndike Street (West)	37	22	C	37	22	C	37	22	C	0	37	22	C
Crossing First Street (North)	83	22	C	83	22	C	90	22	C	0	90	22	C
Crossing First Street (South)	111	22	C	111	22	C	120	22	C	0	120	22	C
<i>Weekday Evening:</i>													
Crossing Thorndike Street (West)	42	22	C	42	22	C	42	22	C	0	42	22	C
Crossing First Street (North)	129	22	C	129	22	C	137	22	C	0	137	22	C
Crossing First Street (South)	163	22	C	163	22	C	173	22	C	0	173	22	C
First Street at Charles Street/Cambridgeside Place:													
<i>Weekday Morning:</i>													
Crossing Cambridgeside Place (East)	112	16	B	112	16	B	112	16	B	0	112	16	B
Crossing Charles Street (West)	38	16	B	38	16	B	38	16	B	0	38	16	B
Crossing First Street (North)	129	16	B	137	16	B	148	16	B	0	148	16	B
Crossing First Street (South)	29	16	B	29	16	B	31	16	B	0	31	16	B
<i>Weekday Evening:</i>													
Crossing Cambridgeside Place (East)	197	16	B	197	16	B	197	16	B	0	197	16	B
Crossing Charles Street (West)	76	16	B	76	16	B	76	16	B	0	76	16	B
Crossing First Street (North)	306	16	B	314	16	B	333	16	B	0	333	16	B
Crossing First Street (South)	70	16	B	70	16	B	74	16	B	0	74	16	B

^aDemand in pedestrians per hour.

^bAverage delay per pedestrian (in seconds).

^cPedestrian Level of Service.

Table 11.1 (Continued)
PEDESTRIAN LEVEL-OF-SERVICE SUMMARY – SIGNALIZED INTERSECTIONS

Intersection/Time Period/Crossing Path	2020 Existing			2020 Modified Baseline			2020 Build			Delay Increase	2025 Future		
	Demand ^a	Delay ^b	LOS ^c	Demand	Delay	LOS	Demand	Delay	LOS		Demand	Delay	LOS
Land Boulevard at Cambridgeside Place and Hotel Driveway:													
<i>Weekday Morning:</i>													
Crossing Cambridgeside Place (West)	74	34	D	74	34	D	74	34	D	0	74	34	D
Crossing Land Boulevard (North)	154	34	D	154	34	D	154	34	D	0	154	34	D
<i>Weekday Evening:</i>													
Crossing Cambridgeside Place (West)	60	34	D	60	34	D	60	34	D	0	60	34	D
Crossing Land Boulevard (North)	309	34	D	309	34	D	309	34	D	0	309	34	D
Land Boulevard at Binney Street:													
<i>Weekday Morning:</i>													
Crossing Binney Street (West)	36	55	E	36	55	E	36	55	E	0	36	55	E
Crossing Land Boulevard (North)	35	49	E	35	49	E	35	49	E	0	35	49	E
Crossing Land Boulevard (South)	12	50	E	12	50	E	12	50	E	0	12	50	E
<i>Weekday Evening:</i>													
Crossing Binney Street (West)	19	55	E	19	55	E	19	55	E	0	19	55	E
Crossing Land Boulevard (North)	47	49	E	47	49	E	47	49	E	0	47	49	E
Crossing Land Boulevard (South)	22	50	E	22	50	E	22	50	E	0	22	50	E
Binney Street at First Street:													
<i>Weekday Morning:</i>													
Crossing Binney Street (East)	80	33	D	80	33	D	80	33	D	0	80	33	D
Crossing Binney Street (West)	171	33	D	171	33	D	171	33	D	0	171	33	D
Crossing First Street (North)	48	38	D	48	38	D	48	38	D	0	48	38	D
Crossing First Street (South)	85	38	D	85	38	D	85	38	D	0	85	38	D
<i>Weekday Evening:</i>													
Crossing Binney Street (East)	86	33	D	86	33	D	86	33	D	0	86	33	D
Crossing Binney Street (West)	146	33	D	146	33	D	146	33	D	0	146	33	D
Crossing First Street (North)	64	38	D	64	38	D	64	38	D	0	64	38	D
Crossing First Street (South)	98	38	D	98	38	D	98	38	D	0	98	38	D

^aDemand in pedestrians per hour.

^bAverage delay per pedestrian (in seconds).

^cPedestrian Level of Service.

Table 11.1 (Continued)
PEDESTRIAN LEVEL-OF-SERVICE SUMMARY – SIGNALIZED INTERSECTIONS

Intersection/Time Period/Crossing Path	2020 Existing			2020 Modified Baseline			2020 Build			Delay Increase	2025 Future		
	Demand ^a	Delay ^b	LOS ^c	Demand	Delay	LOS	Demand	Delay	LOS		Demand	Delay	LOS
Binney Street at Second Street:													
<i>Weekday Morning:</i>													
Crossing Binney Street (East)	110	31	D	110	31	D	110	31	D	0	110	31	D
Crossing Binney Street (West)	130	31	D	130	31	D	130	31	D	0	130	31	D
Crossing Second Street (North)	98	18	B	98	18	B	98	18	B	0	98	18	B
Crossing Second Street (South)	32	18	B	32	18	B	32	18	B	0	32	18	B
<i>Weekday Evening:</i>													
Crossing Binney Street (East)	68	31	D	68	31	D	68	31	D	0	68	31	D
Crossing Binney Street (West)	94	31	D	94	31	D	94	31	D	0	94	31	D
Crossing Second Street (North)	77	18	B	77	18	B	77	18	B	0	77	18	B
Crossing Second Street (South)	24	18	B	24	18	B	24	18	B	0	24	18	B
Binney Street at Third Street:													
<i>Weekday Morning:</i>													
Crossing Binney Street (East)	316	19	B	316	19	B	316	19	B	0	316	19	B
Crossing Binney Street (West)	430	19	B	430	19	B	430	19	B	0	430	19	B
Crossing Third Street (North)	133	19	B	133	19	B	133	19	B	0	133	19	B
Crossing Third Street (South)	76	19	B	76	19	B	76	19	B	0	76	19	B
<i>Weekday Evening:</i>													
Crossing Binney Street (East)	411	19	B	411	19	B	411	19	B	0	411	19	B
Crossing Binney Street (West)	158	19	B	158	19	B	158	19	B	0	158	19	B
Crossing Third Street (North)	171	19	B	171	19	B	171	19	B	0	171	19	B
Crossing Third Street (South)	115	19	B	115	19	B	115	19	B	0	115	19	B
Broadway at Third Street:													
<i>Weekday Morning:</i>													
Crossing Broadway (East)	1,479	25	C	1,479	25	C	1,479	25	C	0	1,479	25	C
Crossing Broadway (West)	283	25	C	283	25	C	283	25	C	0	283	25	C
Crossing Third Street (North)	133	27	C	133	27	C	133	27	C	0	133	27	C
<i>Weekday Evening:</i>													
Crossing Broadway (East)	1,407	25	C	1,407	25	C	1,407	25	C	0	1,407	25	C
Crossing Broadway (West)	403	25	C	403	25	C	403	25	C	0	403	25	C
Crossing Third Street (North)	194	27	C	194	27	C	194	27	C	0	194	27	C

^aDemand in pedestrians per hour.

^bAverage delay per pedestrian (in seconds).

^cPedestrian Level of Service.

Table 11.2
PEDESTRIAN LEVEL-OF-SERVICE SUMMARY – UNSIGNALIZED INTERSECTIONS

Intersection/Time Period/Crossing Path	2020 Existing			2020 Modified Baseline			2020 Build			Delay Increase	2025 Future		
	Demand ^b	Delay ^c	LOS ^d	Demand	Delay	LOS	Demand	Delay	LOS		Demand	Delay	LOS
<i>First Street at Spring Street/Upper Garage:</i>													
<i>Weekday Morning:</i>													
Crossing Spring Street (West)	74	9	B	74	9	B	74	11	C	2	74	12	C
<i>Weekday Evening:</i>													
Crossing Spring Street (West)	138	3	A	138	3	A	138	3	A	0	138	3	A
<i>Cambridgeside Place at Mid-Block Crossing:</i>													
<i>Weekday Morning:</i>													
Crossing Cambridgeside Place	323	23	D	323	24	D	325	26	D	2	325	40	E
<i>Weekday Evening:</i>													
Crossing Cambridgeside Place	345	2,468	F	345	4,294	F	349	12,798	F	8,504	349	39,138	F

^aDemand in pedestrians per hour.

^bAverage delay per pedestrian (in seconds).

^cPedestrian Level of service.

12.0 BICYCLE ANALYSIS

A review of bicycle conditions was conducted at the affected intersections and street segments. First Street provides dedicated on-street lanes for bicyclists while Binney Street provides on-street bike lanes and separated bike lanes. Other city streets in the study area such as Second Street, Third Street, and Cambridge Street are wide enough to permit bicycle travel but do not provide exclusive bicycle lanes. State roadways such as Land Boulevard and O'Brien Highway do not provide bike lanes.

12.1 VEHICLE TURNING VOLUME CONFLICTS

City guidelines require identification of conflicting vehicle-turning volumes at intersections impacted by the Project where bicycle facilities are present or where peak-hour bicycle volumes exceed 10 bicycles on any approach. The locations meeting these criteria are listed in Table 12 for 2020 Modified Baseline and 2020 Build conditions. The mitigation measures proposed at these locations would not impact the ability of bicyclists to safely traverse the study area roadways or intersections.

Table 12
BICYCLE-VEHICLE VOLUME CONFLICTS

Roadway/Intersecting Street/Time Period	Approach Bicycle Volume	Conflicting Vehicles Turning Volume			
		2020 Modified Baseline		2020 Build	
		Advancing Volume	Opposing Volume	Advancing Volume	Opposing Volume
<i>O'Brien Highway at Museum Way:</i>					
Weekday Morning	EB – 39	1,392	0	1,409	0
	WB – <10	--	--	--	--
	SB -- <10	--	--	--	--
Weekday Evening	EB – 10	1,194	0	1,204	0
	WB – 19	1,367	84	1,382	84
	SB -- <10	--	--	--	--
<i>O'Brien Highway at Land Boulevard/Charles Street:</i>					
Weekday Morning	EB – <10	--	--	--	--
Weekday Evening	EB – <10	--	--	--	--
	WB – 21	1,352	401	1,367	404
	NB -- <10	--	--	--	--
<i>O'Brien Highway at Cambridge Street/East Street:</i>					
Weekday Morning	EB – 16	1,185	821	1,234	898
	WB – 10	737	1,192	774	1,241
	NB -- 128	382	316	387	317
	SB – 14	86	67	86	71
Weekday Evening	EB – <10	--	--	--	--
	WB – 28	795	172	804	172
	NB -- 13	799	550	859	575
	SB – 55	119	869	119	929
<i>Cambridge Street at First Street:</i>					
Weekday Morning	EB – 163	264	41	300	58
	WB – 50	593	0	630	0
	NB -- 12	185	0	193	0
	SB – <10	--	--	--	--
Weekday Evening	EB – 26	283	21	281	20
	WB – 111	300	0	317	0
	NB -- 38	601	0	663	0
<i>O'Brien Highway at Third Street:</i>					
Weekday Morning	EB – <10	--	--	--	--
	WB – <10	--	--	--	--
Weekday Evening	WB – 10	1,041	0	1,084	0

*See notes at end of table.

Table 12 (Continued)
BICYCLE-VEHICLE VOLUME CONFLICTS

Roadway/Intersecting Street/Time Period	Approach Bicycle Volume	Conflicting Vehicles Turning Volume			
		2020 Modified Baseline		2020 Build	
		Advancing Volume	Opposing Volume	Advancing Volume	Opposing Volume
<i>Cambridge Street at Third Street:</i>					
Weekday Morning	EB – 72	407	106	419	107
	WB – <10	--	--	--	--
	SB – <10	--	--	--	--
Weekday Evening	EB – <10	--	--	--	--
	WB – 50	440	295	458	303
	NB -- <10	--	--	--	--
	SB – <10	--	--	--	--
<i>First Street at Thorndike Street:</i>					
Weekday Morning	EB – <10	--	--	--	--
	NB – 17	164	322	172	377
	SB – 35	322	0	377	0
Weekday Evening	EB – <10	--	--	--	--
	NB -- 32	329	164	370	175
	SB – 15	164	0	175	0
<i>First Street at Spring Street/Upper Garage:</i>					
Weekday Morning	EB – <10	--	--	--	--
	NB -- 19	308	467	320	501
	SB – 36	446	353	501	395
Weekday Evening	EB – <10	--	--	--	--
	WB – <10	--	--	--	--
	NB -- 34	356	546	430	0
	SB – 29	281	149	312	138
<i>First Street at Lower Garage West Entrance:</i>					
Weekday Morning	NB -- 20	344	76	394	146
	SB – 36	207	0	254	0
Weekday Evening	NB -- 26	389	33	485	105
	SB – 19	183	0	234	0
<i>First Street at Cambridgeside Place/Charles Street:</i>					
Weekday Morning	EB – <10	--	--	--	--
	WB – 10	172	92	187	96
	NB -- 11	214	46	247	46
	SB – 32	192	214	207	247
Weekday Evening	EB – <10	--	--	--	--
	WB – 14	247	395	331	455
	NB -- 26	255	130	291	124
	SB – 24	221	254	222	291

NOTE: NB = Northbound; SB = Southbound; EB = Eastbound; WB = Westbound; LT = Left Turn movement; TH = Through movement; RT = Right Turn movement.

Table 12 (Continued)
BICYCLE-VEHICLE VOLUME CONFLICTS

Roadway/Intersecting Street/Time Period	Approach Bicycle Volume	Conflicting Vehicles Turning Volume			
		2020 Modified Baseline		2020 Build	
		Advancing Volume	Opposing Volume	Advancing Volume	Opposing Volume
<i>Cambridgeside Place at Lower Garage Exit:</i>					
Weekday Morning	EB – <10	--	--	--	--
	WB – 10	164	18	164	50
Weekday Evening	EB – 12	271	252	265	295
	WB – 10	125	374	125	501
<i>Cambridgeside Place at Lower Garage Entrance:</i>					
Weekday Morning	EB – <10	--	--	--	--
	WB – 10	377	213	426	262
Weekday Evening	EB – 12	523	0	560	0
	WB – 10	240	115	256	131
<i>Land Boulevard at Cambridgeside Place/ Hotel Driveway:</i>					
Weekday Morning	EB – <10	--	--	--	--
	WB – <10	--	--	--	--
	NB -- <10	--	--	--	--
	SB – 19	1,686	170	1,725	184
Weekday Evening	EB – <10	--	--	--	--
	NB -- <10	--	--	--	--
	SB – <10	--	--	--	--
<i>Land Boulevard at Lower Garage East Entrance:</i>					
Weekday Morning	SB – 24	1,773	87	1,825	100
Weekday Evening	SB – 14	1,029	7	1,059	9
<i>Land Boulevard at Binney Street:</i>					
Weekday Morning	EB – <10	--	--	--	--
	NB -- <10	--	--	--	--
	SB – <10	--	--	--	--
Weekday Evening	EB – <10	--	--	--	--
	NB -- <10	--	--	--	--
	SB – <10	--	--	--	--

NOTE: NB = Northbound; SB = Southbound; EB = Eastbound; WB = Westbound; LT = Left Turn movement; TH = Through movement; RT = Right Turn movement.

Table 12 (Continued)
BICYCLE-VEHICLE VOLUME CONFLICTS

Roadway/Intersecting Street/Time Period	Approach Bicycle Volume	Conflicting Vehicles Turning Volume			
		2020 Modified Baseline		2020 Build	
		Advancing Volume	Opposing Volume	Advancing Volume	Opposing Volume
<i>Binney Street at First Street:</i>					
Weekday Morning	EB – <10	--	--	--	--
	WB – 14	1,245	262	1,282	327
	NB -- <10	--	--	--	--
	SB – 14	224	74	231	78
Weekday Evening	EB – 14	473	667	482	667
	WB – <10	--	--	--	--
	NB -- <10	--	--	--	--
	SB – <10	--	--	--	--
<i>Binney Street at Second Street:</i>					
Weekday Morning	EB – <10	--	--	--	--
	WB – 16	720	61	733	61
	NB -- <10	--	--	--	--
	SB – <10	--	--	--	--
Weekday Evening	EB – 12	507	27	514	27
	WB – 10	413	102	423	102
	NB -- <10	--	--	--	--
	SB – <10	--	--	--	--
<i>Binney Street at Third Street:</i>					
Weekday Morning	EB – 20	377	72	398	74
	WB – 15	680	22	681	22
	NB -- 10	230	479	281	527
	SB – 21	406	155	413	155
Weekday Evening	EB – 13	751	109	753	109
	WB – 13	380	44	390	44
	NB -- 26	366	333	380	342
	SB – 14	247	411	251	429
<i>Broadway at Third Street:</i>					
Weekday Morning	EB – 168	482	52	482	52
	WB – 25	671	523	727	579
	SB – 23	383	117	384	118
Weekday Evening	EB – 21	634	48	634	48
	WB – 139	396	531	401	536
	SB – 45	485	84	484	83

NOTE: NB = Northbound; SB = Southbound; EB = Eastbound; WB = Westbound; LT = Left Turn movement; TH = Through movement; RT = Right Turn movement.

13.0 ARTICLE 19 SPECIAL PERMIT CRITERIA ANALYSIS

Under Section 19.25.1, the Planning Board shall only grant a Section 19.20 Project Review Special Permit upon finding that the Project will have no substantial adverse impact on City traffic within the study area analyzed in the TIS. Substantial adverse impact is measured by reference to the Special Permit Criteria, which consist of five traffic impact indicators used to evaluate Project impacts. The indicators are: (1) project vehicle trip generation weekdays and weekends for a twenty-four hour period and AM and PM peak vehicle trips generated; (2) change in level of service at identified signalized intersections; (3) increased volume of trips on residential streets; (4) increase of length of vehicle queues at identified signalized intersections; and (5) lack of sufficient pedestrian and bicycle facilities. The methodology for the analysis of the traffic impact indicators is from the Cambridge “Guidelines for Presenting Information to the Planning Board”, approved November 27, 2001, and revised in 2004. Referenced in the guidelines are capacity analysis procedures presented in the *Highway Capacity Manual* (HCM) and summarized in the Appendix. Exceedance of one or more indicators suggests a potentially substantial adverse impact on City traffic; however, the Planning Board should also consider proposed Project mitigation in making its finding. The following section summarizes the 379 measurements analyzed in applying the five indicators to the proposed Project and the proposed Project mitigation. While the Project directly results in exceedance of ten (10) measurements, the methods described in the Mitigation section of this TIS outweigh any potential adverse impact of the Project.

Indicator 1: Project Vehicle – Trip Generation

The Project satisfies the City standards for Indicator 1 regarding vehicle trip-generation as demonstrated by the 3 measurements detailed in Table 13.a.

Indicator 2: Project Vehicle – Level-Of-Service

The Project satisfies 37 of 42 City standards for Indicator 2 regarding vehicle LOS as demonstrated by the measurements detailed in Table 13.b.

Indicator 3: Traffic on Residential Streets

The Project satisfies the City standards for Indicator 3 regarding traffic on residential streets as demonstrated by the 4 measurements detailed in Table 13.c.

Indicator 4: Lane Queue

The Project satisfies 228 of 232 City standards for Indicator 4 regarding lane queues as demonstrated by the measurements detailed in Table 13.d.

Indicator 5: Lack of Sufficient Pedestrian and Bicycle Facilities

The Project satisfies 87 of 98 City standards for Indicator 5A, 5B, and 5C regarding pedestrian and bicycle facilities as demonstrated by the measurements detailed in Table 13.e.1 and Table 13.e.2. Of the 98 measurements analyzed in connection with Criteria 5, only one was exceeded as a result of the Project. A total of ten measurements are exceeded under existing conditions, with or without the Project.

Table 13.a
INDICATOR 1
PROJECT VEHICLE-TRIP GENERATION

Weekday =	860	AM Peak Hour =	132	PM Peak Hour =	92	Exceeds Criteria? [Y/N]	N/N/N
-----------	-----	----------------	-----	----------------	----	-------------------------	-------

Table 13.b
INDICATOR 2
PROJECT VEHICLE-LEVEL-OF-SERVICE

Intersection	Weekday Morning Peak Hour			Weekday Evening Peak Hour		
	Modified Baseline	With Project	Exceeds Criteria?	Modified Baseline	With Project	Exceeds Criteria?
O'Brien Highway at Museum Way	C	C	N	C	C	N
O'Brien Highway at Land Boulevard/Charlestown Avenue	F	F	N	F	F	N
O'Brien Highway at Cambridge Street/East Street	F	E	N	C	D	N
Cambridge Street at First Street	B	B	N	D	E	Y
O'Brien Highway at Third Street	E	E	N	D	C	N
Cambridge Street at Third Street	C	C	N	D	D	N
First Street at Thorndike Street	A	A	N	C	E	Y
First Street at Charles Street and Cambridgeside Place	B	B	N	E	F	Y
Land Boulevard at Cambridgeside Place and Hotel Driveway	B	D	N	C	D	N
Land Boulevard at Binney Street	D	D	N	B	B	N
Land Boulevard at First Street	B	B	N	C	D	N
Binney Street at Second Street	C	C	N	C	C	N
Binney Street at Third Street	C	C	N	D	D	N
Broadway at Third Street	C	C	N	C	C	N

Table 13.b Continued
INDICATOR 2
PROJECT VEHICLE-LEVEL-OF-SERVICE

Intersection	Weekday Morning Peak Hour			Weekday Evening Peak Hour		
	Modified Baseline	With Project	Exceeds Criteria?	Modified Baseline	With Project	Exceeds Criteria?
Cambridgeside Place at Garage South Exit						
SB LT	A	A	N	F	F	Y
SB RT	A	A	N	B	C	N
First Street at Garage West Entrance						
NB TH/RT	A	A	N	A	B	N
SB LT/TH	A	A	N	F	F	Y
Cambridgeside Place at Garage South Entrance						
EB TH	A	A	N	F	F	N
WB TH	A	A	N	A	A	N
WB RT	A	A	N	A	A	N

Table 13.c
INDICATOR 3 – TRAFFIC VOLUME INCREASE ON RESIDENTIAL STREETS

Street Segment	Weekday Morning Peak Hour			Weekday Evening Peak Hour		
	Modified Baseline Volume	With Project	Exceeds Criteria?	Modified Baseline Volume	With Project	Exceeds Criteria?
Charles Street, Second Street to First Street (Amount of residential = <1/3)	107	120	N	228	229	N
Third Street, O'Brien Highway to Cambridge Street (Amount of residential = >1/3 but <1/2)	856	870	N	1,217	1,231	N

Table 13.d
INDICATOR 4 – LANE QUEUE

Intersection	No. of	Weekday Morning Peak Hour			Weekday Evening Peak Hour		
	Lanes Analyzed	Modified Baseline	With Project	Exceeds Criteria?	Modified Baseline	With Project	Exceeds Criteria?
<i>O'Brien Highway at Museum Way:</i>	7						
O'Brien Highway EB LT		2	2	N	2	2	N
O'Brien Highway EB TH		5	5	N	4	4	N
O'Brien Highway EB TH		5	5	N	5	5	N
O'Brien Highway WB TH		10	10	N	10	10	N
O'Brien Highway WB TH		7	6	N	9	9	N
O'Brien Highway WB TH/RT		2	2	N	5	7	N
Museum Way SB LT/RT		7	7	N	4	5	N
<i>O'Brien Highway at Land Boulevard /Charlestown Avenue:</i>	16						
O'Brien Highway EB LT		3	3	N	9	9	N
O'Brien Highway EB LT		19	19	N	17	27	Y
O'Brien Highway EB TH		27	28	N	13	20	Y
O'Brien Highway EB TH		27	29	N	10	15	N
O'Brien Highway EB RT		16	16	N	0	0	N
O'Brien Highway WB LT		8	8	N	8	8	N
O'Brien Highway WB TH		3	4	N	6	7	N
O'Brien Highway WB TH		4	4	N	6	6	N
O'Brien Highway WB RT		4	4	N	6	6	N
Land Boulevard NB LT		6	4	N	23	24	N
Land Boulevard NB TH		16	14	N	32	32	N
Land Boulevard NB TH		16	15	N	32	32	N
Land Boulevard NB RT		5	5	N	23	27	N
Charlestown Avenue SB LT/TH		10	10	N	7	6	N
Charlestown Avenue SB LT/TH		16	16	N	14	14	N
Charlestown Avenue SB TH/RT	16	16	N	16	15	N	

Table 13.d
INDICATOR 4 – LANE QUEUE (Continued)

Intersection	No. of	Weekday Morning Peak Hour			Weekday Evening Peak Hour		
	Lanes Analyzed	Modified Baseline	With Project	Exceeds Criteria?	Modified Baseline	With Project	Exceeds Criteria?
<i>O'Brien Highway at Cambridge Street /East Street:</i>	13						
O'Brien Highway EB LT		3	3	N	4	4	N
O'Brien Highway EB TH		16	10	N	10	8	N
O'Brien Highway EB TH		18	12	N	9	7	N
O'Brien Highway EB TH		19	13	N	7	5	N
O'Brien Highway EB RT		2	3	N	1	1	N
O'Brien Highway WB LT		3	3	N	2	3	N
O'Brien Highway WB LT		2	3	N	3	4	N
O'Brien Highway WB TH		2	2	N	7	7	N
O'Brien Highway WB TH/RT		2	2	N	8	7	N
Cambridge Street NB LT/TH		2	2	N	3	3	N
Cambridge Street NB RT		1	2	N	2	2	N
Cambridge Street NB RT		1	1	N	1	1	N
East Street SB LT/TH/RT	2	2	N	2	2	N	
<i>Cambridge Street at First Street:</i>	6						
Cambridge Street EB TH/RT		3	5	N	9	14	N
Cambridge Street WB LT		4	4	N	3	3	N
Cambridge Street WB TH		2	2	N	3	2	N
First Street NB LT		1	2	N	5	5	N
First Street NB RT		3	3	N	8	8	N
Bus Station SB LT/TH/RT	0	0	N	0	0	N	
<i>O'Brien Highway at Third Street:</i>	8						
O'Brien Highway EB TH		14	16	N	7	7	N
O'Brien Highway EB TH		14	18	N	6	6	N
O'Brien Highway EB TH/RT		15	19	N	6	6	N
O'Brien Highway WB LT/TH		2	2	N	13	13	N
O'Brien Highway WB TH		2	2	N	14	12	N
O'Brien Highway WB TH		2	2	N	14	13	N
Third Street NB LT		2	2	N	4	3	N
Third Street NB LT/RT	10	4	N	7	6	N	

Table 13.d
INDICATOR 4 – LANE QUEUE (Continued)

Intersection	No. of	Weekday Morning Peak Hour			Weekday Evening Peak Hour		
	Lanes Analyzed	Modified Baseline	With Project	Exceeds Criteria?	Modified Baseline	With Project	Exceeds Criteria?
<i>Cambridge Street at Third Street:</i>	5						
Cambridge Street EB LT/TH/RT		8	9	N	10	10	N
Cambridge Street WB LT/TH/RT		5	6	N	9	8	N
Third Street NB LT/TH/RT		4	4	N	9	9	N
Third Street SB LT		2	2	N	1	1	N
Third Street SB TH/RT		9	9	N	4	4	N
<i>First Street at Thorndike Street:</i>	4						
Thorndike Street EB LT		1	1	N	2	2	N
Thorndike Street EB RT		2	2	N	2	5	N
First Street NB TH		2	2	N	11	7	N
First Street SB TH		4	4	N	7	10	N
<i>First Street at Charles Street and Cambridgeside Place:</i>	4						
Charles Street EB LT/TH/RT		2	2	N	6	8	N
Cambridgeside Place WB LT/ RT		3	3	N	5	6	N
First Street NB TH/RT		3	3	N	5	12	N
First Street SB LT/TH		3	3	N	7	7	N
<i>Land Boulevard at Cambridgeside Place and Hotel Driveway:</i>	12						
Cambridgeside Place EB LT		2	2	N	12	11	N
Cambridgeside Place EB LT/TH		2	2	N	12	11	N
Cambridgeside Place EB RT		0	0	N	0	0	N
Hotel Driveway WB LT/TH/RT		2	1	N	2	3	N
Land Boulevard NB LT		4	10	N	7	9	N
Land Boulevard NB TH		3	22	Y	10	14	N
Land Boulevard NB TH		3	16	Y	8	12	N
Land Boulevard NB TH/RT		3	3	N	5	7	N
Land Boulevard SB LT		6	8	N	4	6	N
Land Boulevard SB TH		7	9	N	6	6	N
Land Boulevard SB TH		9	10	N	7	5	N
Land Boulevard SB TH/RT		2	2	N	2	2	N

Table 13.d
INDICATOR 4 – LANE QUEUE (Continued)

Intersection	No. of	Weekday Morning Peak Hour			Weekday Evening Peak Hour		
	Lanes Analyzed	Modified Baseline	With Project	Exceeds Criteria?	Modified Baseline	With Project	Exceeds Criteria?
<i>Land Boulevard at Binney Street:</i>	10						
Binney Street EB LT		2	3	N	3	3	N
Binney Street EB LT		3	3	N	3	3	N
Land Boulevard NB LT		17	18	N	6	6	N
Land Boulevard NB LT		17	17	N	4	5	N
Land Boulevard NB TH		11	13	N	10	10	N
Land Boulevard NB TH		5	4	N	7	7	N
Land Boulevard NB TH		2	2	N	3	3	N
Land Boulevard SB TH		11	11	N	5	6	N
Land Boulevard SB TH		11	11	N	6	7	N
Land Boulevard SB RT	7	7	N	1	1	N	
<i>Binney Street at First Street:</i>	8						
Binney Street EB LT		2	3	N	1	2	N
Binney Street EB TH		2	2	N	2	2	N
Binney Street EB TH/RT		3	3	N	3	3	N
Binney Street WB LT/TH		5	5	N	2	2	N
Binney Street WB TH/RT		5	5	N	2	2	N
First Street NB LT/TH/RT		3	3	N	2	2	N
First Street SB LT/TH		4	5	N	10	11	N
First Street SB RT	2	2	N	3	3	N	
<i>Binney Street at Second Street:</i>	7						
Binney Street EB LT		1	1	N	2	2	N
Binney Street EB TH/RT		5	6	N	4	5	N
Binney Street WB LT		2	2	N	1	1	N
Binney Street WB TH		6	6	N	4	4	N
Binney Street WB TH/RT		6	6	N	4	4	N
Second Street NB LT/TH/RT		2	2	N	6	7	N
Second Street SB LT/TH/RT	5	5	N	3	3	N	

Table 13.d
INDICATOR 4 – LANE QUEUE (Continued)

Intersection	No. of	Weekday Morning Peak Hour			Weekday Evening Peak Hour		
	Lanes Analyzed	Modified Baseline	With Project	Exceeds Criteria?	Modified Baseline	With Project	Exceeds Criteria?
<i>Binney Street at Third Street:</i>	9						
Binney Street EB LT		2	2	N	7	7	N
Binney Street EB TH		4	4	N	6	9	N
Binney Street EB TH/RT		3	3	N	4	7	N
Binney Street WB LT		4	5	N	2	2	N
Binney Street WB TH		5	4	N	3	3	N
Binney Street WB TH/RT		5	5	N	4	4	N
Third Street NB LT/TH		3	4	N	5	5	N
Third Street NB RT		2	2	N	3	3	N
Third Street SB LT/TH/RT	8	8	N	5	5	N	
<i>Broadway at Third Street:</i>	7						
Broadway EB LT		4	4	N	5	5	N
Broadway EB TH		4	3	N	6	6	N
Broadway EB TH/RT		1	1	N	3	3	N
Broadway WB TH		8	8	N	5	5	N
Broadway WB RT		4	5	N	2	2	N
Third Street SB LT/TH		6	6	N	6	5	N
Third Street SB RT	3	3	N	2	1	N	

Table 13.e.1
INDICATOR 5A – PEDESTRIAN LEVEL OF SERVICE

Intersection	Weekday Morning Peak Hour			Weekday Evening Peak Hour		
	Modified Baseline PLOS	With Project	Exceeds Criteria?	Modified Baseline PLOS	With Project	Exceeds Criteria?
<i>O'Brien Highway at Museum Way:</i> Crossing O'Brien Highway (East) Crossing O'Brien Highway (West) Crossing Museum Way (North)	D D D	D D D	N N N	D D D	D D D	N N N
<i>O'Brien Highway at Land Boulevard/Charlestown Avenue:</i> Crossing O'Brien Highway (West) Crossing Land Boulevard (South)	D E	D E	N Y	D D	D D	N N
<i>O'Brien Highway at Cambridge Street/East Street:</i> Crossing O'Brien Highway (East) Crossing O'Brien Highway (West) Crossing East Street (North)	C C C	C C C	N N N	C C C	C C C	N N N
<i>Cambridge Street at First Street/Bus Station Driveway:</i> Crossing Cambridge Street (East) Crossing Cambridge Street (West) Crossing First Street (South)	C C C	C C C	N N N	C C C	C C C	N N N
<i>O'Brien Highway at Third Street:</i> Crossing O'Brien Highway (East) Crossing Third Street (South)	C C	C C	N N	C C	C C	N N

Table 13.e.1 (Continued)
INDICATOR 5A – PEDESTRIAN LEVEL OF SERVICE

Intersection	Weekday Morning Peak Hour			Weekday Evening Peak Hour		
	Modified Baseline PLOS	With Project	Exceeds Criteria?	Modified Baseline PLOS	With Project	Exceeds Criteria?
<i>Cambridge Street at Third Street:</i> Crossing Cambridge Street (East) Crossing Cambridge Street (West) Crossing Third Street (North) Crossing Third Street (South)	B B B B	B B B B	N N N N	B B B B	B B B B	N N N N
<i>First Street at Thorndike Street:</i> Crossing Thorndike Street (West) Crossing First Street (North) Crossing First Street (South)	C C C	C C C	N N N	C C C	C C C	N N N
<i>First Street at Spring Street/Upper Garage:</i> Crossing Spring Street (West)	B	C	Y	A	A	N
<i>First Street at Charles Street/Cambridgeside Place:</i> Crossing Cambridgeside Place (East) Crossing Charles Street (West) Crossing First Street (North) Crossing First Street (South)	B B B B	B B B B	N N N N	B B B B	B B B B	N N N N
<i>Cambridgeside Place at Mid-Block Crossing:</i> Crossing Cambridgeside Place	D	D	N	F	F	Y
<i>Land Boulevard at Cambridgeside Place and Hotel Driveway:</i> Crossing Cambridgeside Place (West) Crossing Land Boulevard (North)	D D	D D	N N	D D	D D	N N

Table 13.e.1 (Continued)
INDICATOR 5A – PEDESTRIAN LEVEL OF SERVICE

Intersection	Weekday Morning Peak Hour			Weekday Evening Peak Hour		
	Modified Baseline PLOS	With Project	Exceeds Criteria?	Modified Baseline PLOS	With Project	Exceeds Criteria?
<i>Land Boulevard at Binney Street:</i>						
Crossing Binney Street (West)	E	E	Y	E	E	Y
Crossing Land Boulevard (North)	E	E	Y	E	E	Y
Crossing Land Boulevard (South)	E	E	Y	E	E	Y
<i>Binney Street at First Street:</i>						
Crossing Binney Street (East)	D	D	N	D	D	N
Crossing Binney Street (West)	D	D	N	D	D	N
Crossing First Street (North)	D	D	N	D	D	N
Crossing First Street (South)	D	D	N	D	D	N
<i>Binney Street at Second Street:</i>						
Crossing Binney Street (East)	D	D	N	D	D	N
Crossing Binney Street (West)	D	D	N	D	D	N
Crossing Second Street (North)	B	B	N	B	B	N
Crossing Second Street (South)	B	B	N	B	B	N
<i>Binney Street at Third Street:</i>						
Crossing Binney Street (East)	B	B	N	B	B	N
Crossing Binney Street (West)	B	B	N	B	B	N
Crossing Third Street (North)	B	B	N	B	B	N
Crossing Third Street (South)	B	B	N	B	B	N
<i>Broadway at Third Street:</i>						
Crossing Broadway (East)	C	C	N	C	C	N
Crossing Broadway (West)	C	C	N	C	C	N
Crossing Third Street (North)	C	C	N	C	C	N

Table 13.e.2
INDICATOR 5B AND 5C – PEDESTRIAN AND BICYCLE FACILITIES

Adjacent Street or Public Right-of-Way	Sidewalks or Walkways Present?	Exceeds Criteria?	Bicycle Facilities or Right-of-Ways Present?	Exceeds Criteria?
Cambridgeside Place	Y	N	N	Y
Land Boulevard	Y	N	N	Y
First Street	Y	N	Y	N

14.0 PROJECT MITIGATION

14.1 PROJECT MITIGATION

Generally, the Project's location near transit facilities such as Lechmere Station as well as the area shuttle services significantly encourages transit use by employees, residents and visitors to the proposed Project. Mitigation efforts are therefore geared towards measures to improve traffic congestion on these adjacent streets as well as efforts to encourage Project employees and residents towards alternative transportation that would result in a low single occupant vehicle (SOV) rate for the Project. To improve traffic flow on roadways adjacent to the Project, improvements consisting of signal equipment upgrades along with signal retiming efforts and pedestrian enhancements at locations closest to the Project is proposed. The Applicant has also committed to contributing funds to be used towards a corridor study of First Street and Second Street to assist the City in determining appropriate and feasible improvements. Additionally, the Project proposes implementation of a TDM Plan and modifications to improve roadway and pedestrian facilities that outweigh any potential adverse impacts of the Project on the surrounding street network.

14.2 INTERSECTION UPGRADES

The intersection of Land Boulevard with Cambridgeside Place and the Hotel Sonesta driveway has older pedestrian signal equipment and non-American with Disabilities Act (ADA)-compliant wheelchair ramps. In addition, the traffic signal equipment and vehicle detection at this location is also outdated, leading to instances of missed vehicle calls to the signal, particularly for the northbound left-turn movement into Cambridgeside Place.

Accordingly, it is recommended that the traffic signal equipment at this location be replaced with the latest technology, including hybrid video/radar cameras for detection of pedestrians, bicycles, and vehicles to provide a fully-actuated traffic signal. This equipment will allow the constant optimization of green time for approaches that have most demand. Assuming optimum signal timing conditions results in the following operations at the signalized intersections in the study area shown in Table 14.1 with queue results shown in Table 14.2.

**Table 14.1
MITIGATED VEHICLE LEVEL-OF-SERVICE SUMMARY – LAND BOULEVARD AT
CAMBRIDGESIDE PLACE AND HOTEL DRIVEWAY**

/Peak Hour/Movement	2020 Build		2020 Build Mitigated		2025 Future		2025 Future Mitigated	
	Delay ^a	LOS ^b	Delay	LOS	Delay	LOS	Delay	LOS
<i>Weekday Morning Peak Hour:</i>								
Cambridgeside Place EB LT	37	D	42	D	39	D	51	D
Cambridgeside Place EB LT/TH	34	C	43	D	34	C	34	C
Cambridgeside Place EB RT	1	A	1	A	1	A	1	A
Hotel Driveway WB LT/TH/RT	28	C	30	C	26	C	24	C
Land Boulevard NB LT	174	F	70	E	170	F	52	D
Land Boulevard NB TH	282	F	22	C	189	F	25	C
Land Boulevard NB TH	15	B	15	B	17	B	18	B
Land Boulevard NB TH/RT	13	B	13	B	14	B	15	B
Land Boulevard SB LT	52	D	42	D	48	D	45	D
Land Boulevard SB TH	8	A	9	A	9	A	10	A
Land Boulevard SB TH	10	A	11	B	11	B	12	B
Land Boulevard SB TH/RT	10	A	9	A	9	A	12	B
Overall	38	D	21	B	42	D	21	C
<i>Weekday Evening Peak Hour:</i>								
Cambridgeside Place EB LT	118	F	94	F	138	F	88	F
Cambridgeside Place EB LT/TH	92	F	66	E	110	F	65	E
Cambridgeside Place EB RT	1	A	1	A	1	A	1	A
Cambridgeside Place EB RT	62	E	51	D	72	E	42	D
Hotel Driveway WB LT/TH/RT	146	F	56	E	153	F	72	E
Land Boulevard NB LT	62	E	74	E	241	F	67	E
Land Boulevard NB TH	52	D	75	E	190	F	71	E
Land Boulevard NB TH	30	C	59	E	123	F	56	E
Land Boulevard NB TH/RT	62	E	78	E	80	F	66	E
Land Boulevard SB LT	11	B	14	B	10	B	14	B
Land Boulevard SB TH	13	B	16	B	13	B	16	B
Land Boulevard SB TH	7	A	9	A	9	B	9	A
Land Boulevard SB TH/RT	44	D	47	D	99	F	45	D
Overall								

^aAverage delay per vehicle (in seconds).

^bLevel of service.

NB = northbound; SB = southbound; WB = westbound; SB = southbound; LT = left-turn movement; TH = through movement; RT = right-turn movement.

**Table 14.2
MITIGATED QUEUE ANALYSIS RESULTS – LAND BOULEVARD AT CAMBRIDGESIDE PLACE AND
HOTEL DRIVEWAY^a**

Lane	Weekday Morning Peak Hour				Weekday Evening Peak Hour			
	2020 Build	2020 Build Mitigated	2025 Future	2025 Future Mitigated	2020 Build	2020 Build Mitigated	2025 Future	2025 Future Mitigated
	Calculated	Calculated	Calculated	Calculated	Calculated	Calculated	Calculated	Calculated
Cambridgeside Place EB LT	2	2	2	2	11	11	10	9
Cambridgeside Place EB LT/TH	2	2	2	2	11	11	11	9
Cambridgeside Place EB RT	0	0	0	0	0	0	0	0
Hotel Driveway WB LT/TH/RT	1	2	1	1	3	2	3	2
Land Boulevard NB LT	10	7	10	7	9	7	10	7
Land Boulevard NB TH	22	5	23	5	14	13	30	13
Land Boulevard NB TH	16	3	17	4	12	11	27	12
Land Boulevard NB TH/RT	3	2	5	3	7	9	24	10
Land Boulevard SB LT	8	6	5	5	6	9	7	5
Land Boulevard SB TH	9	9	8	9	6	9	8	9
Land Boulevard SB TH	10	11	10	12	5	9	9	9
Land Boulevard SB TH/RT	2	2	2	2	2	2	2	2

Note: EB = eastbound; WB = westbound; NB = northbound; SB = southbound; LT = left-turning movements; TH = through movements; RT = right-turning movements.

^aAll queues calculated using SimTraffic methodology. Queue in vehicles per lane.

The intersection can be placed into coordinated operation at such time that the traffic signals at Binney Street and O'Brien Highway can be linked to provide improved operations and progression on Land Boulevard. In addition to the LED signal and pedestrian heads, audible countdown timers, and light touch Accessible Pedestrian Signal (APS) pushbuttons will be installed at the ends of the crosswalks across Land Boulevard and Cambridgeside Place. New signal mast arms and pedestal poles will also be installed. The intersection will be repaved with high visibility standard-type crosswalks installed across both roadways, consistent with the crosswalk markings proposed for the Route 28 corridor project or other as recommended by the City of Cambridge and/or DCR.

The sidewalks along the Project side of Land Boulevard and Cambridgeside Place will also be improved. These will be easier and safer for pedestrians to navigate than the existing brick sidewalks which can shift in placement over time and be uneven for pedestrians.

14.3 ADDITIONAL MITIGATION MEASURES

Consistent with efforts to minimize the generation of SOV trips and to also provide better management of existing traffic congestion while improving surface transit reliability and service, the following additional mitigation measures have been identified:

- **FIRST STREET AND SECOND STREET CORRIDOR STUDY** – As discussed with TP&T, CambridgeSide will contribute funds to be used towards a corridor study of First Street and Second Street that could review feasibility of road features such as bus priority lanes on First Street, dedicated bicycle lanes on Second Street, use of street frontage for ride-hailing service parking, parklets, and other curb-oriented uses.
- **BLUEBikes SPONSORSHIP** – Expands CambridgeSide's participation in the Bluebikes program and provides Gold-level corporate membership in Bluebikes for a 10-year period for all tenants.
- **EAST CAMBRIDGE TRANSIT EXPANSION PROGRAM** – Monetary contribution to the City of Cambridge intended as an initial funding level to be used for funding the review of local transit improvements, such as funds towards the Grand Junction Rail with Trail, a Lechmere to Kendall Shuttle, and any future MBTA bus service that may use the corridor.
- **TRANSIT SUBSIDIES** – CambridgeSide will direct tenants to provide Transit Subsidies to tenants' employees for use towards transit passes (MBTA and EZRide), BLUEbikes programs, and parking charges at Park & Ride lots.
- **EXPANDED CAMBRIDGESIDE SHUTTLE BUS OPERATIONS** – Anticipation of expansion to CambridgeSide Shuttle between New Lechmere Station, Kendall Square Station, and site.
- **POTENTIAL EZRIDE SHUTTLE BUS CONSOLIDATION** – Review of consolidation of EZRide shuttle services with CambridgeSide Shuttle route to provide expanded shuttle services and cross connections with EZRide stops including North Station and Central Square.

14.4 TRANSPORTATION DEMAND MANAGEMENT MEASURES

CambridgeSide currently provides a number of Transportation Demand Management (TDM) measures consistent with local conditions of the original CambridgeSide approval that were intended to reduce SOV travel and encourage the use of alternative modes of transportation. The measures are provided below in italics with the current status also provided.

- *Provide details of a shuttle bus system including routes, schedules, frequency and capacity serving the development, other developments and the East Cambridge transit stations* – Currently implemented through both the Charles River TMA EZ Ride shuttle bus system providing service between Kendall Square and North Station as well as the CambridgeSide Shuttle Bus that provides service between CambridgeSide and Kendall Square free of charge.
- *Implement a computer based ride sharing information bank to assist commuters seeking van pool and car pool arrangements* – Currently implemented through membership in the Charles River TMA.
- *Plan for participation in the MBTA commuter pass program for all employees and tenants of this development* – Previously implemented with employees, tenants, and visitors able to purchase MBTA passes at the CambridgeSide information desk. The MBTA is in the process of revising their technology for point of sale pass purchase and this service is temporarily unavailable.
- *Provide details of an on-going program to survey customers and employees (including tenants) to determine travel modes, times of arrival and departure, home location, and preferences for ride sharing among other information* – Currently implemented as the Annual Transportation Monitoring Report.
- *Allow for up to 50 percent of the bicycle parking facilities required by Article 6.000 to be located elsewhere in the East Cambridge riverfront district in public parks and other suitable locations* – Currently implemented through short-term bicycle parking spaces located around Canal Park and on Cambridgeside Place.

In addition to these ongoing commitments, CambridgeSide will implement the following TDM measures to supplement the existing program and encourage alternatives to SOV use by the new office employees:

- Encourage employees to obtain a Charlie card and register it for bike parking, allowing employees the ability to use the bike cages at area MBTA stations and other areas free of charge;
- Make available public transportation schedules, which will be posted in a centralized location for employees along with Transitscreens™ to be located in the lobbies of main buildings;
- Provide information on available pedestrian and bicycle facilities in the vicinity of the project site in a central location for employees;
- Charge for parking at market rates and offer discounted parking for dedicated HOV vehicles;
- Provide language in lease documents ensuring that employers are required to provide MBTA pass subsidies to employees up to the federal maximum (currently \$270 per month);
- Provide information about transportation options available to employees at orientations and on a company website; and
- Encourage employers to work with the Cambridge Office of Workforce Development.

14.5 MITIGATION STAGING

The Scoping Letter requested a description of how transportation mitigation measures could be linked to milestones, thresholds, or performance standards as the Project develops in multiple stages. The Project is currently proposed to be built in two stages, with the 20 CS and 60 First Street components to be constructed by 2023. The remaining components are expected to be completed afterwards, potentially by 2027. This allows for the performance of the TDM plan to be monitored and supplementary mitigation to be implemented if required.

A Traffic Monitoring Plan is currently in place at CambridgeSide and will be used to gauge success of the TDM program. The following data is currently collected and will continue to be collected after completion of the Project:

- Survey of customers and employees (including tenants) to determine travel modes, times of arrival and departure, home location, and preferences for ride sharing among other information.
- Provide garage and parking counts for a one-week period on an annual basis.
- Provide updates of tenants, leased building area, employee totals, and year-to-year mode split comparison, including the calculation of the Employee and Patron SOV rate.
- Provide updates of required TDM measures including status of Emergency Ride Home (ERH), loaner bikes for Hotel Marlowe, and Electric Vehicle (EV) charging stations on site.

Collectively, this effort is compiled as the CambridgeSide TDM Annual Report Summary and is provided to the City of Cambridge Community Development Department, Parking and Transportation Demand Management Planning Officer, and Traffic, Parking, & Transportation Department. It is anticipated that this effort will continue after the Project is completed as a condition of local approval.

Primary to these percentages with regard to roadway congestion, is the percentage of the site population driving alone to a place of employment or to shop, referred to as the Single Occupant Vehicle (SOV). This mode has the greatest effect on congestion and parking use, and the TDM measures that have been identified are aimed at limiting and reducing the SOV percentage associated with the Project. While it typically takes some time after full occupancy to realize the full effects of any TDM program, the proposed measures to limit the SOV percentage and promote other modes will be in place at lease inception.

The monitoring program will apply to all tenants on an annual basis and shall commence one year after the issuance of a Certificate of Occupancy. If, after a period of two years following the later to occur of the issuance of a final Certificate of Occupancy for the second new buildings or the issuance of a final Certificate of Occupancy for more than 325,000 square feet of net new gross floor area (Sears/60 First Street and Macy's/20 CambridgeSide or Best Buy/110 First Street) the Project materially fails to meet (SOV) mode split percentages as identified in the traffic assessment, it is recommended that the following additional improvements be considered:

- **SIGNAL CORRIDOR TIMING STUDY.** The Proponent will escrow funds for a Signal Corridor Timing Study (SCTS) for the Route 28 Corridor between Third Street and Museum Way and for the Land Boulevard Corridor between O'Brien Highway and Binney Street. These funds will be placed into an escrow account which can be drawn on by the Proponent to fund a study of the effects of modified timing or phasing of traffic signals on these corridors to improve traffic flow, recognizing that improvements to signal equipment and detection are proposed to be implemented by others prior to CambridgeSide's proposed completion. The SCTS can also review the applicability of Adaptive Signal Control Technology (ASCT) to these corridors, after the improvements by others have been constructed and all transportation changes in the area have been implemented. It is recommended that the SCTS review operations during a weekday morning time

period (6:30 AM to 9:30 AM), a weekday afternoon/evening time period (3:00 PM to 7:00 PM), and a Saturday midday time period (11:00 AM to 3:00 PM).

- **SIGNAL TIMING OPTIMIZATION/ADAPTIVE SIGNAL CONTROL TECHNOLOGY INSTALLATION.** The Proponent will escrow funds for implementation of signal timing modifications for the same corridors identified above, if the results of the SCTS indicate that current signal timing/phasing designs requires modification. These funds will include amounts for design, implementation, and installation of ASCT at these locations, if the SCTS indicates doing so will improve traffic operations.

The escrow funds will be returned to the Proponent for other potential improvements within the study area network or other purposes contemplated by local approvals if funds remain at the earlier to occur of two (2) years after the completion of the Project or ten (10) years following issuance of the building permit for the first new building in the Project.

Accordingly, the Applicant has proposed implementing Project mitigation in stages as shown in Table 14.3.

**Table 14.3
POTENTIAL MITIGATION STAGING**

Development Stage	Anticipated Year of Completion	Corresponding Mitigation	
		Signal Systems and Geometric Improvements	Additional Mitigation Measures
20 CS/60 First Street	2023	Reconstruction of pedestrian facilities at the Land Boulevard, Cambridgeside Place, and Sonesta driveway intersection to provide ADA-compliant pedestrian crossings	<p>First Street/Second Street Corridor Study Funding</p> <p>Expanded CS/EZRide Shuttle Bus Service</p> <p>Standard TDM Measures, including:</p> <ul style="list-style-type: none"> • BLUEBikes sponsorship • Transit Subsidies • Ridematching Services • Annual Transportation Monitoring • Charge market rates for parking • Install Transitscreens™ in lobbies
110 First Street/80&90 First Street	2027	<p>Signal Corridor Timing Study (8 locations)</p> <p>Signal Timing Optimization/ Adaptive Signal Control Technology (ASCT) Installation (8 locations)</p>	<p>East Cambridge Transit Expansion Program Funding</p> <p>Continued CS/EZRide Shuttle Bus Service</p> <p>Standard TDM Measures, including:</p> <ul style="list-style-type: none"> • BLUEBikes sponsorship • Transit Subsidies • Ridematching Services • Annual Transportation Monitoring • Charge market rates for parking • Install Transitscreens™ in lobbies

These values would be developed for each stage and compared to results obtained after completion of the respective stage of the Project. It should be noted that the Applicant has a vested interest in ensuring the success of the transportation system in the immediate area. Accordingly, the measures identified above are provided as a means to validate the intentions of the Applicant towards improvements to the transportation system. It is anticipated that the Traffic, Parking, & Transportation Department and the Community Development Department may have additional input into this monitoring reporting process, and the Applicant will meet to discuss and review any concerns and comments Staff may have. An exhibit identifying the locations where physical improvements are proposed is provided as Figure 14.b.1.

In order to reduce any potential impacts of the Project, the Applicant proposes implementation of the above-described mitigation measures, including continued TDM strategies, the expansion of the CambridgeSide shuttle bus and potential consolidation with the EZRide shuttle services, and providing funds for additional study of Transit Expansion and the First Street corridor to improve traffic conditions in the area. Enhanced traffic signal technologies, signal timing adjustments, and pedestrian improvements are also proposed at the Land Boulevard, Cambridgeside Place, and Hotel Sonesta driveway in an effort to improve the efficiency and pedestrian connectivity between the Project and areas along Land Boulevard. The Project will also provide minimal parking ratios and expanded bicycle parking and storage, all measures that are proven to reduce the demand for personal vehicles. Continued monitoring of the Project's SOV percentage and parking utilization with potential additional signal corridor studies and ASCT implementation will provide additional improvements if warranted due to the Project development. These benefits are substantial and will address existing congestion and reduce the overall effect of the Project, ensuring the viability of CambridgeSide and continuing the role of CambridgeSide as an active, vibrant, and stable attraction in East Cambridge.

15.0 CONCLUSION

As described throughout this TIS, the Project consists of the redevelopment of an existing, once-thriving, retail facility into a diverse mixed-use development. Approximately half of the retail floor area will be retained while additions of office, R&D, and residential land uses will be incorporated. The proposed uses reduce the net traffic effect of the site from what was historically one of the more intensive traffic generators to one that is more easily managed through promotion of alternative transportation and shifting of peak commuting hours.

The Project is located in an area close to extensive public transit networks where reliance on personal vehicles is becoming less necessary and through the provision of minimal parking ratios, expanded bicycle parking and storage, aggressive TDM measures, and proximity to expanded transit services and transit connectivity, the overall traffic impact of the Project will be reduced. Improved traffic signal technologies designed to address current congestion in the area will also be implemented to further reduce the Project's impact on the area road network. Additionally, the Project will significantly improve the pedestrian and bicycle connectivity and experience at the site through widened sidewalks and improved conditions (e.g., lighting), encouraging increased usage of these alternative modes of transportation.

The proposed Project will not result in a public hazard due to substantially increased vehicular traffic or parking in this area of East Cambridge. Specifically, the Project is not anticipated to have a significant adverse impact on motorist delays in the area and adequate parking supply will exist at the site to support the Project. Accordingly, this TIS finds that the Project can be accommodated within the existing area infrastructure and on the roadway network with minimal effects, resulting in the ability to implement the Project's planned mix of uses with the appropriate mitigation measures.

CITY OF CAMBRIDGE
Special Permit Transportation Impact Study (TIS)

Summary Sheet

Planning Board Permit Number: _____

Project Name: CambridgeSide 2.0 Redevelopment

Address: 100 Cambridgeside Place, Cambridge, MA

Owner/Developer Name: New England Development

Contact Person: John Twohig

Contact Address: 75 Park Plaza

Boston, MA 02109

Contact Phone: 617-243-7071

ITE sq. ft.: 200 Apartments, 350,000 sf of office space, 665,000 sf of research and development space, 375,000 of retail space

Zoning sq. ft.: _____

Land Use Type: Mixed-Use

Existing Parking Spaces: 2,490 Use: Mixed-Use

New Parking Spaces: 1,695 Use: Mixed-Use

Date of Parking Registration Approval: _____

Trip Generation:	Daily	AM Peak Hour	PM Peak Hour
Total Trips	6,838	886	840
Vehicle	2,838	369	350
Transit	2,484	322	305
Pedestrian	480	59	57
Bicycle	410	53	50
Other	626	83	78

Mode Split (person trips):	Residential		Office/R&D	
	Vehicle:	%	Office/R&D	%
	<u>36</u>	%	<u>42</u>	%
	<u>29</u>	%	<u>37</u>	%
	<u>29</u>	%	<u>5</u>	%
	<u>6</u>	%	<u>6</u>	%
	<u>0</u>	%	<u>10</u>	%

Transportation Consultant: Vanasse and Associates, Inc.

Contact Name: Scott W. Thornton, P.E.

Phone: 978-474-8800

Date of Building Permit Approval: _____



Ref: 7810

July 22, 2020

Mr. Joseph E. Barr, Director
Department of Traffic, Parking, and Transportation
City of Cambridge
344 Broadway
Cambridge, MA 02139

Re: Responses to City of Cambridge Traffic, Parking, & Transportation comment letter dated June 24, 2020 on the CambridgeSide 2.0 Transportation Impact Study (TIS)

Dear Joe:

In order to facilitate your review of the updated CambridgeSide 2.0 TIS, Vanasse & Associates, Inc. (VAI) is pleased to submit responses to the June 24, 2020 letter from the City of Cambridge Traffic, Parking, & Transportation (TP&T). For ease of review, we have listed the comments followed by our responses:

TP&T Comment Letter – June 24, 2020

TP&T Comment 1: *“Page 9. As stated in the TIS scope, Table 1.a.1 is not clear on the Project’s existing, proposed, and net new square feet by individual land uses. Please provide the information more clearly.”*

VAI Response: Table 1.a.1 is intended to explain the Project building areas as they relate to the calculation of Net New GFA as defined in the zoning for the PUD-8 parcel.

TP&T Comment 2: *“Page 35. It is unclear why the utilization of the 362 long-term parking spaces was separated out of the parking utilization data, and this should be explained more clearly, including why parking utilization counts could not be conducted manually for those spaces.”*

VAI Response: The reason for separating the 362 long-term parking spaces out of the parking utilization data is due to the fact the Sonesta and Marlowe spaces are not tracked by the automated counts system in the garage. This system provided the count data for most of the garage users and the data that was used for the analysis for the 2018 time period and for the updated 2019 data. To be accurate, manual counts of the 362 long-term spaces would have to be conducted on the same days as the other counts, which are days that have already passed. Further, such automated and manual counts could not be timely replicated during the time period since receipt of your comments due to the dramatic impact of COVID-19 on parking garage utilization rates across all use categories. To be conservative and to simplify calculations it was assumed all of these spaces are occupied and unavailable to other users. It is important to note that the hotel peak periods do not coincide with the projected peak periods of the new land uses proposed at the site.

TP&T Comment 3: *“Page 42. The Project Trip Generation by Mode Table 3.a.3 indicates 875,000 square feet of Office/R&D use whereas on page 9 in Table 1.a.1 it indicates the project will have 575,000 Net New Gross Square Feet. The discrepancy needs to be clearly explained in both Tables.”*

VAI Response: There is no discrepancy. Table 1.a.1 refers to the Project building areas as they relate to the 575,000 square feet of Net New GFA as defined in the zoning for the PUD-8 parcel. Table 3.a.3 refers to the 875,000 square feet of Office/R&D that is over and above the existing 140,000 sf on the third floor of the core mall. The different numbers reflect not only the calculation of “Net New GFA” as defined in the PUD-8 zoning, but also account for the conversion of uses in connection with the redevelopment.

TP&T Comment 4: *“Page 44. Table 3.a.4 shows 64 “Counted Transient Retail Vehicle Trips” in the weekday morning peak hour. These trips should be more clearly explained since CambridgeSide generally opens at 10 AM and it is therefore unclear why 64 vehicle trips occur in the morning peak hour which is prior to 10 AM?”*

VAI Response: The number of “Counted Transient Retail Vehicle Trips” was determined based on the garage counts which indicate approximately 64 weekday morning peak hour vehicle trips. Although the majority of CambridgeSide opens after 10 AM, the Dunkin’ and Starbucks establishments open earlier. Dunkin’ opens at 5:30 AM Monday to Sunday while the Starbucks opens at 6:30 AM Monday to Friday, 7:30 AM on Saturday, and 8:30 AM on Sunday. Based on the 2018 PTDM report for CambridgeSide, Dunkin’ is listed at 439 square feet (sf) and Starbuck is listed at 1,499 sf. The PTDM report also states that Dunkin’ has 16 employees and Starbucks has 13 employees. Using the Institute of Transportation Engineers (ITE) Land Use Code (LUC) 936 – Coffee/Donut Shop without Drive-Through Window and 1,938 sf the anticipated weekday morning peak hour trips is 196 vehicles (100 entering and 96 exiting). Assuming 30 percent of the trips are made by automobiles, which is reasonable based on the fact the PTDM report states the single occupancy vehicle mode split to be 28 percent, the vehicle trip generation would be around 59 weekday morning peak hour trips. Assuming 2 employees arrive during the weekday morning peak hour for each establishment then the number increases to 63. Base on this reasoning it is reasonable to assume that 64 weekday morning vehicle retail trips would occur.

TP&T Comment 5: *“Page 45. It is unclear in Table 3.a.6 the difference between “Non-Tenant Monthly Parkers: and “Remaining Monthly Parkers”. The Table should be clearer and explain how the data was calculated.”*

VAI Response: The Total Monthly Parkers include employees of tenant companies, non-tenant employees of nearby companies, and parking temporarily displaced by construction and/or temporary contractor parking. The Non-Tenant Monthly Parkers are comprised only of non-tenant employees of nearby companies. The Remaining Monthly Parkers are therefore comprised of the employees of tenant companies and parking temporarily displaced by construction and/or temporary contractor parking. The data was obtained by averaging CambridgeSide garage counts conducted in March, October, and December 2019. As shown in Table 3.a.6 below, the Non-Tenant Monthly Parker Vehicle Trips (B) are subtracted from the



Total Monthly Parker Vehicle Trips (A) to calculate the Remaining Monthly Parker Vehicle Trips (C).

**Table 3.a.6
 MONTHLY PARKER TRIP GENERATION^a**

Time Period/ Directional Distribution	Total Monthly Parker Vehicle Trips (A)	Non-Tenant Monthly Parker Vehicle Trips (B)	Remaining Monthly Parker Vehicle Trips (C=A-B)
<i>Weekday:</i>			
Entering	1,066	630	436
<u>Exiting</u>	<u>1,092</u>	<u>630</u>	<u>462</u>
Total	2,158	1,260	898
<i>Weekday Morning Peak Hour:</i>			
Entering	246	212	34
<u>Exiting</u>	<u>4</u>	<u>1</u>	<u>3</u>
Total	250	213	37
<i>Weekday Evening Peak Hour:</i>			
Entering	10	3	7
<u>Exiting</u>	<u>270</u>	<u>208</u>	<u>62</u>
Total	280	211	69

^aBased on CambridgeSide garage counts and average of days in March, October, and December 2019.

TP&T Comment 6: *“Page 49. The TIS stated that 58% of non-tenant monthly parking trips were assumed to become transit trips and 42% of those trips were redistributed from the lower garage to alternative parking facilities. The TIS should be clearer on exactly what other parking facilities those trips were assigned to. In addition, the networks and the analysis in the TIS showed that 100% of these trips were redistributed to the alternative garages and therefore remain on the road network. TP&T believes that to be conservative, the TIS can keep 100% of the trips assigned into the traffic network and correct the statement on page 49 to indicate that 100% of those non-tenant monthly parking trips were assigned to alternative parking facilities in the area.”*

VAI Response: The statement 58% of non-tenant monthly parking trips were assumed to become transit trips and 42% of those trips were redistributed from the lower garage to alternative parking facilities has been updated to indicate that 100% of those non-tenant monthly parking trips were assigned to alternative parking facilities in the area to provide a conservative scenario. These locations are shown on Figure 3.d.3 in the revised TIS.

TP&T Comment 7: *“The TIS did not show the vehicle level of service (LOS), vehicle queue or delay analysis for the lower garage driveway on First Street (Intersection #9) and the lower garage entrance off CambridgeSide Place (Intersection #12). The analysis for the lower garage’s First Street driveway (Intersection #9) is particularly important because it is unclear if that driveway will be able to accommodate the*



increased demand during the peak hours, especially due to the increase in left turns from First Street into the lower garage and impacts on First Street traffic flow. The TIS should demonstrate whether that driveway will need to be signalized.”

VAI Response:

The vehicle LOS analysis for intersection #9 and #12 is summarized in Table 6.2. As shown in Table 6.2, during the weekday morning the LOS for the critical movements at both intersections operate at LOS A. The northbound movement at intersection #9, during the weekday evening peak hour, under 2020 Existing, 2020 Modified Baseline, and 2020 Build conditions operates at LOS B or better. During the 2025 Future conditions this movement operates at LOS F. The southbound movement at intersection #9, during the weekday evening peak hour, under 2020 Existing, 2020 Modified Baseline, and 2020 Build conditions operates at LOS F. During the 2025 Future conditions this movement operates at LOS C. Under all conditions during the weekday evening peak hour at intersection #12 the two inner eastbound through lanes operate at LOS F while the outer eastbound through/right-turn lane operates at LOS A. The westbound movements at this intersection operate at LOS A under all conditions during the weekday evening peak hour.

A peak hour traffic signal warrant analysis was conducted at intersection #9 under 2025 Future conditions. The Manual on Uniform Traffic Control Devices (MUTCD) establishes nine warrants or criteria to evaluate a location for the installation or retention of a traffic signal. At least one of the nine warrants should be satisfied in order to justify the installation or retention of a traffic signal; however, satisfaction of a warrant in and of itself does not justify traffic signal control. An engineering evaluation of the location in question should indicate that the establishment of traffic signal control will improve the overall safety and/or operation of the intersection. Table 6.3 identifies the nine traffic signal warrants. Table 6.4 summarizes the traffic signal warrant analysis.

As can be seen from Table 6.4, the peak hour traffic volume warrant is not met. Though we did not directly check the 8-hour and 4-hour traffic volume warrants, the minimum minor street volume to meet the 8-hour warrant at 100 percent is 75 and at 80 percent (which can only be applied after an adequate trial of other remedial measures) is 60. In order to meet the 4-hour warrant the minimum minor street volume is 80 vehicles. Technically there is no minor street volume as the garage is entrance only, however there is a condition that states if there is a heavy left-turn volume from the major street then the left turn volume can be considered the minor street volume and the single direction of opposing traffic on the major street the major street volume. Even if we apply this condition the maximum left turn volume during the peak hours is 72 vehicles, which is lower than the minimum threshold of 75 and 80 vehicles defined for the 8-hour and 4-hour warrens. Therefore, a signal is not warranted at this location.



Table 6.2
VEHICLE LEVEL-OF-SERVICE SUMMARY - UNSIGNALIZED INTERSECTIONS

Unsignalized Intersection/ Critical Movement/Peak Hour	2020 Existing			2020 Modified Baseline			2020 Build			Delay	2025 Future		
	Demand ^a	Delay ^b	LOS ^c	Demand	Delay	LOS	Demand	Delay	LOS	Increase	Demand	Delay	LOS
First Street at Lower Garage West Entrance													
Weekday Morning Peak Hour:													
First Street NB TH/RT	333	1	A	344	2	A	394	2	A	0	474	2	A
First Street SB LT/TH	197	1	A	207	2	A	254	3	A	1	341	3	A
Weekday Evening Peak Hour:													
First Street NB TH/RT	383	5	A	389	6	A	485	14	B	8	579	67	F
First Street SB LT/TH	186	56	F	183	51	F	234	55	F	4	297	35	C
Cambridgeside Place at Lower Garage South Entrance													
Weekday Morning Peak Hour:													
Cambridgeside Place EB TH ^d	105	2	A	110	2	A	128	3	A	1	134	3	A
Cambridgeside Place EB TH		4	A		5	A		5	A	0		5	A
Cambridgeside Place EB TH		1	A		1	A		1	A	0		1	A
Cambridgeside Place WB TH	164	1	A	164	1	A	164	1	A	0	185	1	A
Cambridgeside Place WB RT	189	1	A	213	1	A	262	1	A	0	262	1	A
Weekday Evening Peak Hour:													
Cambridgeside Place EB TH	500	293	F	523	298	F	560	354	F	56	581	350	F
Cambridgeside Place EB TH		272	F		274	F		386	F	112		385	F
Cambridgeside Place EB TH		3	A		3	A		3	A	0		2	A
Cambridgeside Place WB TH	125	1	A	125	1	A	125	1	A	0	136	7	A
Cambridgeside Place WB RT	121	1	A	115	1	A	131	1	A	0	131	1	A

^aDemand (in vehicles per hour) for the critical movements.

^bAverage delay per vehicle (in seconds) for the critical movements.

^cLevel of service.

^dEastbound movement not technically part of intersection due to median present on Cambridgeside Place.

NB = northbound; SB = southbound; WB = westbound; SB = southbound; LT = left-turn movement; TH = through movement; RT = right-turn movement.



Table 6.3
TRAFFIC SIGNAL WARRANTS

Warrant No.	Description
1	Eight-Hour Vehicular Volume
2	Four-Hour Vehicular Volume
3	Peak Hour
4	Pedestrian Volume
5	School Crossing
6	Coordinated Signal System
7	Crash Experience
8	Roadway Network
9	Intersection near a Grade Crossing

Table 6.4
TRAFFIC SIGNAL WARRANTS ANALYSIS RESULTS^a
FIRST STREET AT LOWER GARAGE WEST ENTRANCE

Warrant No.	Description	Satisfied for 2025 Future Conditions
1	Eight-Hour Vehicular Volume	--
2	Four-Hour Vehicular Volume	--
3	Peak Hour	No
4	Pedestrian Volume	No
5	School Crossing	No
6	Coordinated Signal System	No
7	Crash Experience	No
8	Roadway Network	No
9	Grade Crossing	No

^aTSWA based on traffic volumes from Figure 5.d.1 and Figure 5.d.2 from the TIS.

TP&T Comment 8: *“The Traffic Network Figures should show the service driveway on First Street and correct the location of intersection #9 (i.e., the Lower Garage driveway is not directly across from Hurley Street).”*

VAI Response: All figures showing intersection #9 have been updated by shifting intersection #9 northward such that it is not directly across from Hurley Street. The service (loading) driveway was not counted; therefore, no traffic volumes would be shown on the traffic network figures.

TP&T Comment 9: *“Page 50. The paragraph under Project Service and Loading and Figures 3.e.1 and 3.e.2 are unclear about the exact changes proposed. The Figures should*



more clearly show the proposed changes between existing and proposed conditions. The number of loading bays located at each service area should also be labeled.”

VAI Response: Figure 3.e.1 and Figure 3.e.2 have been updated and can be found in the updated TIS. The figures show the proposed changes to the loading docks via dashed red lines and the loading bays are all labeled.

TP&T Comment 10: *“Page 60. The TIS indicated level of service (LOS) D for the Monsignor O’Brien Highway at Third Street intersection for the 2020 evening peak hour. This is questionable because the Third Street northbound approach to Monsignor O’Brien Highway usually has a long queue for the northbound approach. The TIS indicates LOS B and only 16 or 17 second delay for this approach. The analysis should be checked to make sure it reflects actual field conditions, making sure that spillback to adjacent intersections has been taken into consideration.”*

VAI Response: We calibrated the SimTraffic model to match the queues that were observed (5-7 vehicles NB on Third Street at O’Brien Highway) and the LOS based on that is a LOS B for the northbound movement. The difference between the observed value and the value noted in Comment 10 could be due to physical limitations in queue observations. Between O’Brien Highway and Gore Street there is approximately 150 feet which can fit approximately 6 vehicles. Queues may have extended beyond Gore Street on Third Street but that was not captured in the queue observations due to physical limitations of the queue observers; therefore it was not accounted for in the SimTraffic model calibration.

TP&T Comment 11: *“Page 81. The TIS indicated that the hotels and former Lotus building leased parking spaces are not fully utilized and the parking analysis conservatively assumed none of the 362 parking spaces would be made available to other users. The TIS should explain the rationale for this assumption and explain if the parking spaces can be legally made available to other users.”*

VAI Response: The lease language for these long-term lease holders precludes the use of the 362 spaces referred to as “committed spaces” for any entity other than their identified users.

TP&T Comment 12: *“Page 84. Table 9.5 shows that in the future, there will be 350 to 467 unused parking spaces depending on the monthly parking demands. This does not appear to be accurate because it doesn’t account for the 362 long-term leased parking spaces. The Table and the discussion must be corrected. Furthermore, If Table 9.5 was accurate and there will be 350 to 467 unused parking spaces in the future, then the TIS should explain why 630 existing non-tenant monthly parkers will need to be removed.”*

VAI Response: Table 9.5 has been updated based on the change to the Project parking demand calculations as detailed in VAI’s response to TP&T Comment 13 below. Therefore the maximum parking utilization (number of spaces) changed. The 362 long term spaces were removed from the calculation and the maximum parking utilization percentages were calculated using a total of 1333 available spaces instead of 1695.



Similarly, the number of unused parking spaces was calculated using 1333 spaces instead of 1695. All of these changes are reflected in the updated Table 9.5, provided below for your reference.

**Table 9.5
 FUTURE PROJECT PARKING UTILIZATION^a**

Time Period	Maximum Parking Utilization (spaces)	Maximum Parking Utilization ^b (Percent)	Unused Parking Spaces
March	1,252	93.9	81
October	1,275	95.6	58
December	1,323	99.2	10
Average	1,283	96.2	50

^aBased on garage data provided by CambridgeSide.

^bBased on 1,333 total spaces. Maximum demand observed at 1pm-2pm.

TP&T Comment 13: *“Page 84. The statement that sufficient parking supply will exist in the Lower Garage to accommodate the demands of the new and existing uses is not accurate because Figure 9.c.3 shows that there will be a shortfall of 12 parking spaces in December during 1-2 PM. The statement should be modified or deleted.”*

VAI Response: The project Parking demand calculations have been updated. Previously, the Project retail parking demand was calculated based on empirical data from garage counts. This resulted in a parking rate for the retail approaching 1.25 spaces per 1,000 sf. Based on discussion with TP&T, the updated analysis calculates the Project retail parking demand based on a rate of 0.7 spaces per 1,000 sf and uses 390,000 sf for retail; 415,000 sf for office; and 685,000 sf for R&D. Parking demand was calculated using these rates and Gross Floor Area as defined in the Zoning Ordinance. In addition, the residential parking demand was revised from 0.5 to 0.75 spaces per unit. Figure 9.c.1, Figure 9.c.2, and Figure 9.a.3 show the updated Project parking demand charts for March, October, and December respectively. Seasonality has also been accounted for with seasonal corrections of 7 percent and 45 percent made to the respective October and December retail patrons parking demand based on the garage data. As shown on Figure 9.c.1-9.c.3 during the peak parking demand from 1:00 PM to 2:00 PM, between 10 and 81 spaces are available within the garage during each of these time periods. Accordingly, sufficient parking supply will exist in the Lower Garage to accommodate the demands of new and existing uses.

TP&T Comment 14: *“Page 84. It is not accurate to exclude 362 committed (long-term lease) parking spaces in the Maximum Parking Utilization column and then include those spaces to calculate the percent parking utilization. The Table needs to include the 362 committed parking spaces; it cannot mix and match numbers. Ideally,*



the parking analysis should include the committed parking spaces and their actual maximum parking utilization to fully understand the parking supply and demand.”

VAI Response: See response to TP&T Comment 12.

TP&T Comment 15: *“As required in the TIS scope, the TIS did not show the expected parking demand by hour, both with and without the monthly parkers. It only showed without the 630 non-tenant monthly parkers. This should be corrected.”*

VAI Response: The practice of providing parking for non-tenant monthly parkers will be phased out as the Project progresses. A condition where all the Project parking demand and the current level of non-tenant monthly parkers are parking in the garage at the same time will not occur. The non-tenant monthly parkers will be discontinued as the Project parking demand increases and the Upper Garage is removed.

TP&T Comment 16: *“Page 84. The TIS should be clearer on what is meant by managed parking optimization systems or managed parking. If the project will be seeking a planning board special permit to allow valet parking, tandem parking, parked vehicles in parking aisles, or any other parking management measure it should be explained in detail, including any upper limits on the number of physical vehicles that could be in the garage at any one time.”*

VAI Response: Pursuant to Section 13.106.2 of the PUD-8 zoning, the Planning Board may approve a managed parking plan. Our special permit application will seek approval from the Planning Board of managed parking in the Lower Garage, as necessary. We anticipate seeking administrative approval of any such managed parking plan from TP&T prior to implementation of the same.

TP&T Comment 17: *“The TIS did not clearly indicate the Project’s proposed minimum and maximum parking ratios by land use; this information needs to be provided in the revised TIS (as a reminder, accessory parking spaces may not be used as commercial parking spaces). Describe in detail and show in a table any proposed sharing of accessory parking spaces between different land uses. Also, indicate what will be the final future number of commercial parking spaces.”*

VAI Response: Table 9.4 has been updated to indicate the minimum, maximum, and expected parking ratios by land use. The PUD-8 District zoning ordinance has no minimum parking requirements for Residential, Retail, Office, or R&D land uses; therefore, there is no need to provide accessory parking spaces. This allows the categorization of the Lower Garage as a commercial parking facility. All spaces (not including the 362 committed spaces) will be allowed to be shared, with the exception of a minimum amount of 75 parking spaces maintained for use by the residents during periods of peak commercial parking utilization (7am to 5pm on weekdays).

TP&T Comment 18: *“Page 85. The required bicycle parking should be based on the future project parameters, not on the previous conditions as shown in Table 9.6. Please correct or clarify the Table.”*



VAI Response: The bicycle parking is based on the future Project parameters. Bike parking has been calculated according to Section 6.103.1 of the Zoning Ordinance, which accounts for bicycle parking based on the construction of a new building as well as based on conversion of existing Gross Floor Area.

TP&T Comment 19: *“Page 85. The TIS and Figures should clarify if the long-term bicycle parking spaces need to be accessed by an elevator. The Figures for the long-term bicycle storage area should also clearly show the access route between the long-term bicycle parking and public right-of-way.”*

VAI Response: The bicycle parking figures (Figure 9.d.1 through Figure 9.d.5) have been updated to indicate how the areas are accessed and are provided in the updated TIS.

TP&T Comment 20: *“Page 97. The TIS stated that mitigation is proposed at the First Street/Spring Street intersection crosswalk (crossing Spring Street) to increase motorist awareness of pedestrians crossing, however it is unclear exactly what is being proposed to increase motorist awareness for this crosswalk. The recommendation should be specific or deleted (if deleted, this can be discussed in more detail during the development of project mitigation recommendations).”*

VAI Response: As discussed with TP&T, mitigation will be determined in consultation with TP&T after review of the re-submitted TIS. Accordingly, this sentence has been deleted pending future discussion with the City.

It is anticipated that this information addresses the comments. Please feel free to contact us directly if there should be any further clarification needed.

Sincerely,

VANASSE & ASSOCIATES, INC.



Scott W. Thornton, P.E.
Senior Associate



Derek Roach, EIT.
Transportation Engineer

cc: A. Shulman – TP&T
J. Twohig, S. Lemke – NED
T. Sullivan, J. Caamano – Goulston & Storrs



Transportation Impact Study

Supporting Graphics Volume I of II

Section 1.0

CambridgeSide 2.0 Redevelopment
Cambridge, Massachusetts

Prepared for:

New England Development, On Behalf Of:

Cambridgeside Galleria Associates Trust,
Cambridgeside Partners LLC, And
NW Cambridge Property Owner LLC

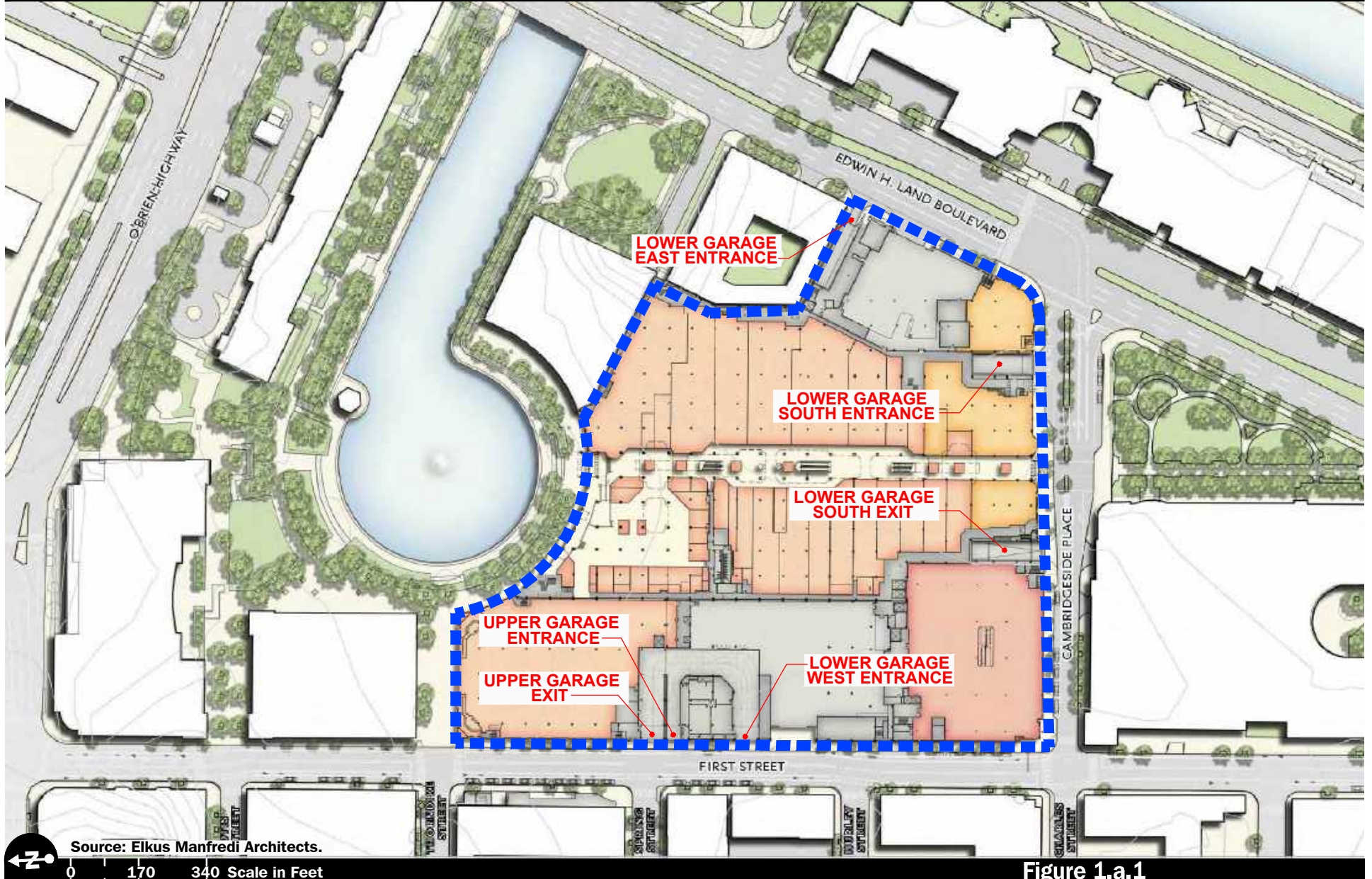
Cambridge, Massachusetts

July 2020

Prepared by:



35 New England Business Center Drive
Suite 140
Andover, MA 01810



Source: Elkus Manfredi Architects.

Figure 1.a.1

Ground Floor Plan with Vehicle Access



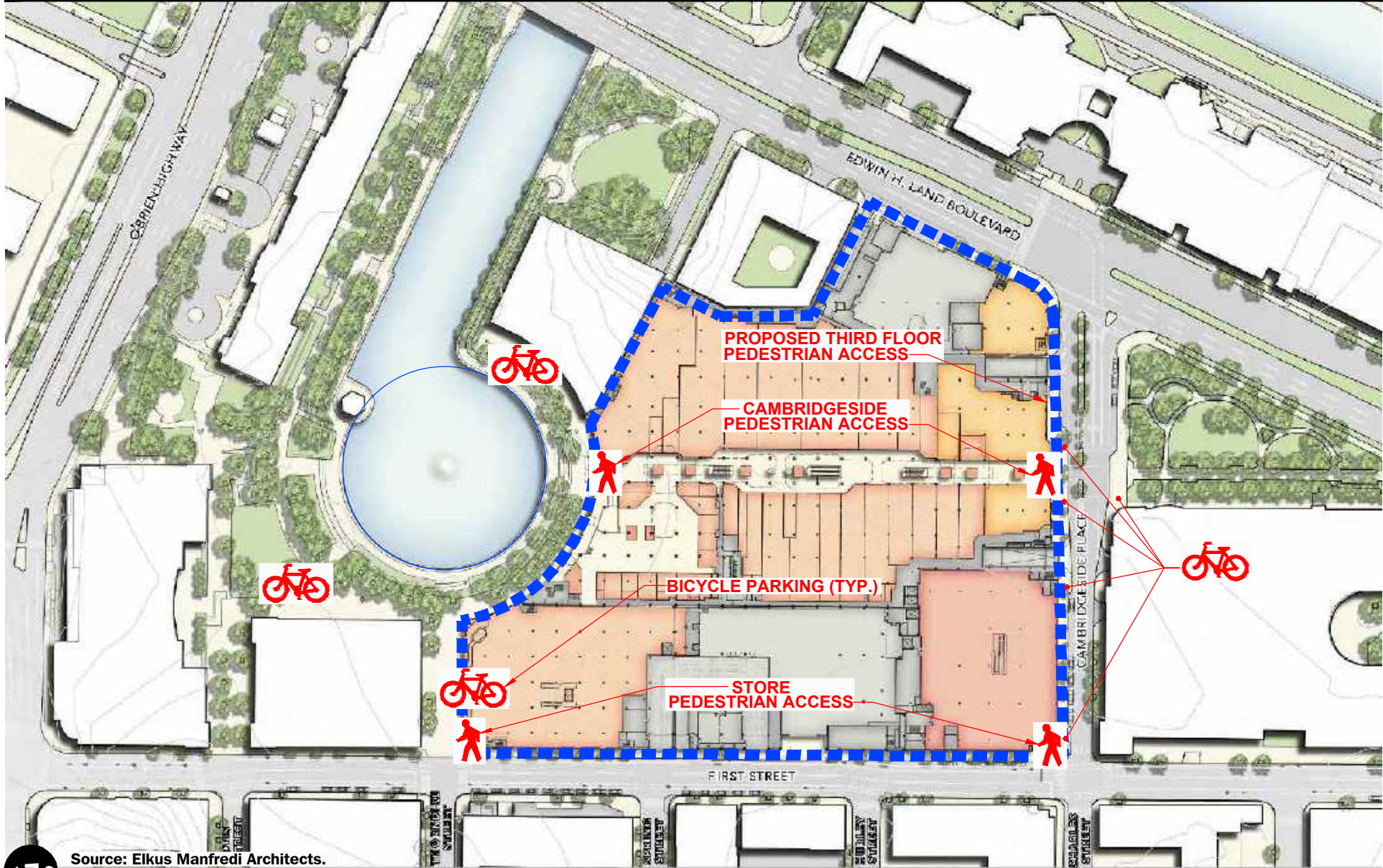
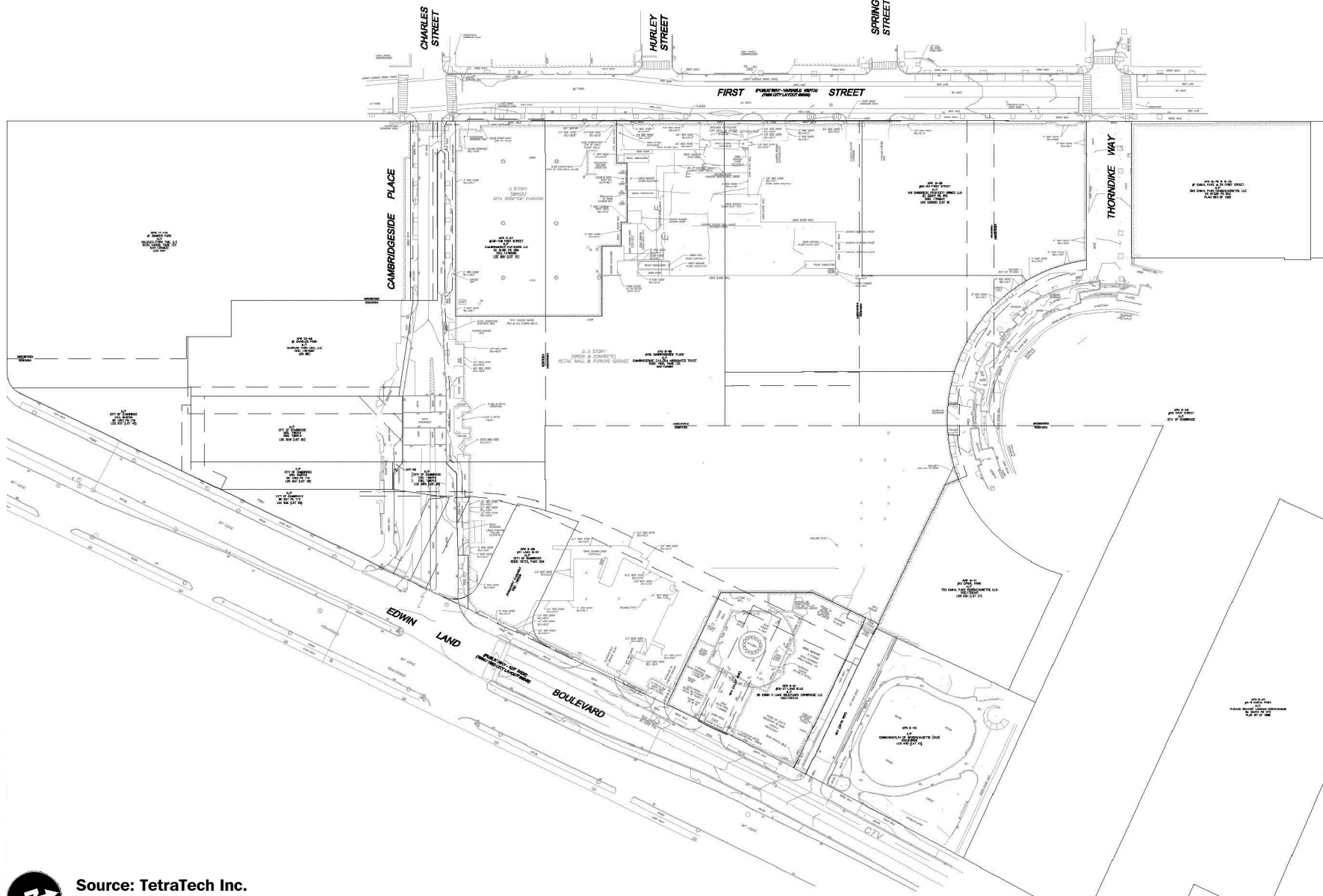


Figure 1.a.2

Ground Floor Plan with Pedestrian and Bicycle Access



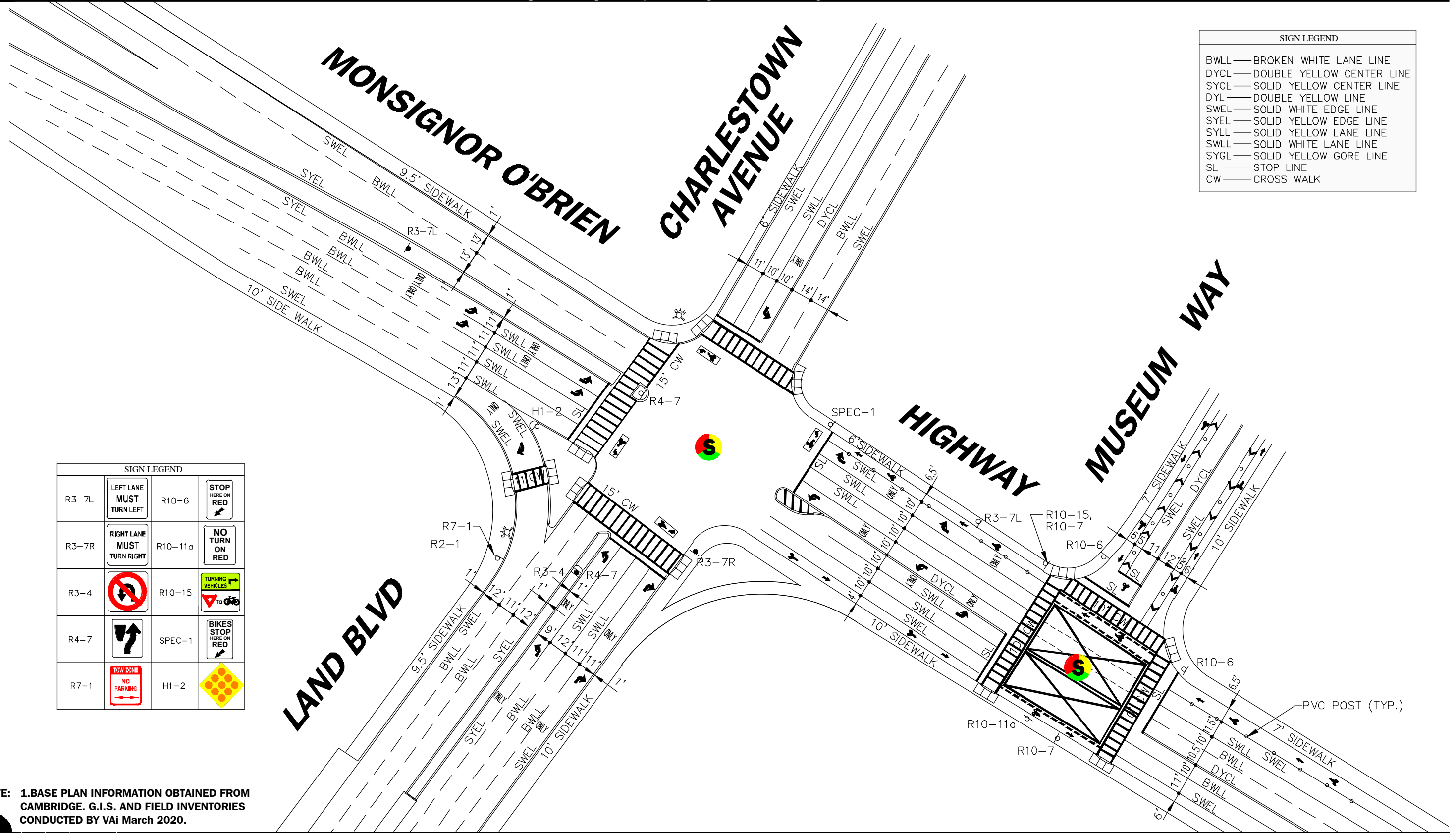
Source: TetraTech Inc.

0 80 160 Scale in Feet



Figure 1.a.3

Existing Conditions Survey



SIGN LEGEND	
BWLL	BROKEN WHITE LANE LINE
DYCL	DOUBLE YELLOW CENTER LINE
SYCL	SOLID YELLOW CENTER LINE
DYL	DOUBLE YELLOW LINE
SWEL	SOLID WHITE EDGE LINE
SYEL	SOLID YELLOW EDGE LINE
SYLL	SOLID YELLOW LANE LINE
SWLL	SOLID WHITE LANE LINE
SYGL	SOLID YELLOW GORE LINE
SL	STOP LINE
CW	CROSS WALK

SIGN LEGEND			
R3-7L	LEFT LANE MUST TURN LEFT	R10-6	STOP HERE ON RED
R3-7R	RIGHT LANE MUST TURN RIGHT	R10-11a	NO TURN ON RED
R3-4		R10-15	TURNING VEHICLES
R4-7		SPEC-1	BIKES STOP HERE ON RED
R7-1	TOWN ZONE NO PARKING	H1-2	

NOTE: 1. BASE PLAN INFORMATION OBTAINED FROM CAMBRIDGE. G.I.S. AND FIELD INVENTORIES CONDUCTED BY VAI March 2020.

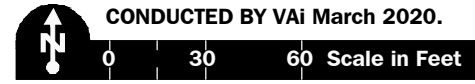
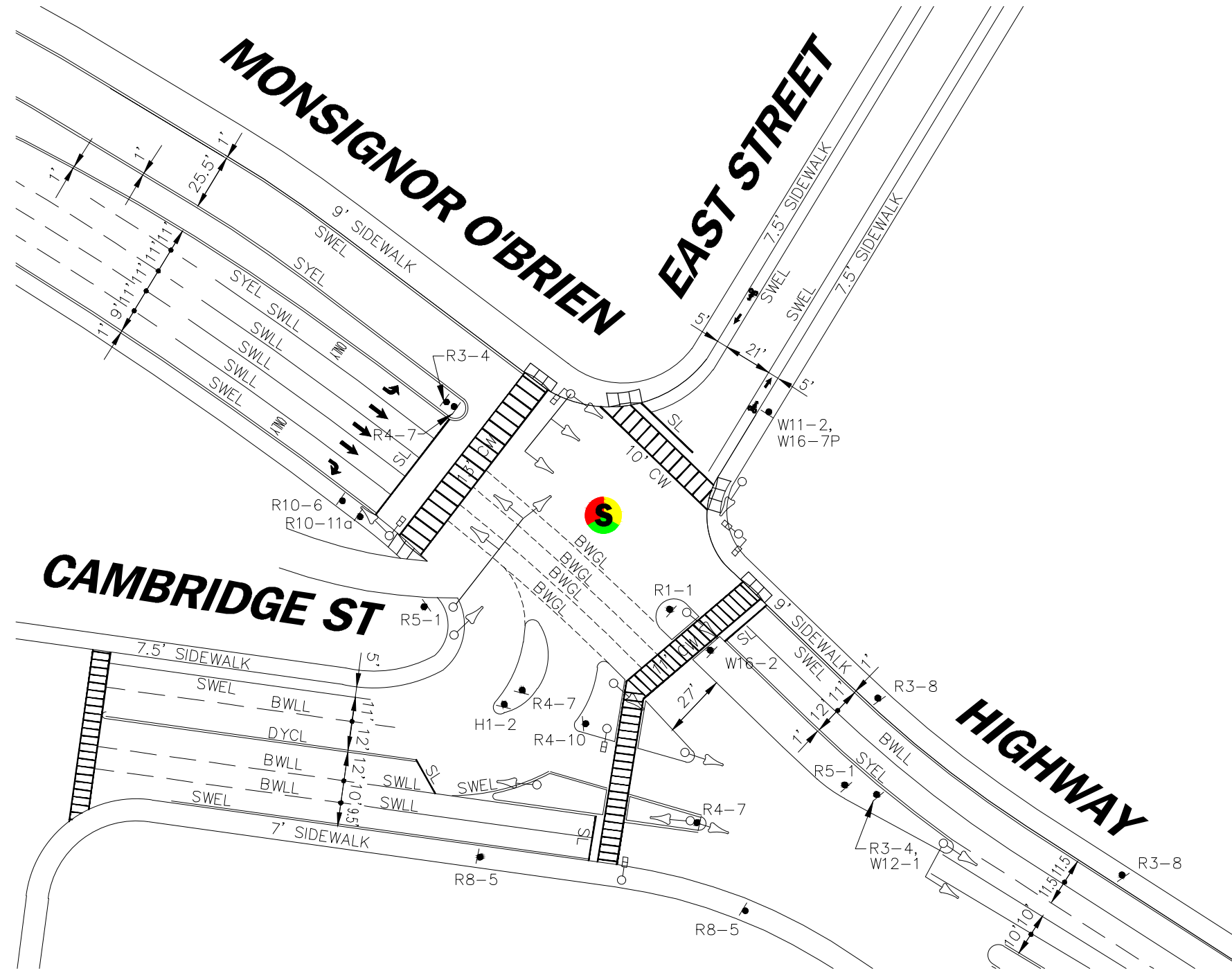


Figure 1.b.1

Intersection Inventory
O'Brien Highway at Land Boulevard /
and Charlestown Avenue and
Museum Way



R:\7810\TIS\7810INVENTORY2.dwg, 5/14/2020 10:35:49 AM



SIGN LEGEND		
R3-1		R8-3
R3-4		R8-5a
R4-7		H1-2
R4-10		W11-2
R5-1		W12-1
R10-6		W16-7P
R10-11a		

SIGN LEGEND	
BWGL	BROKEN WHITE GUIDE LINE
BWLL	BROKEN WHITE LANE LINE
DYCL	DOUBLE YELLOW CENTER LINE
SYCL	SOLID YELLOW CENTER LINE
DYL	DOUBLE YELLOW LINE
SWEL	SOLID WHITE EDGE LINE
SYEL	SOLID YELLOW EDGE LINE
SYLL	SOLID YELLOW LANE LINE
SWLL	SOLID WHITE LANE LINE
SYGL	SOLID YELLOW GORE LINE
SL	STOP LINE
CW	CROSS WALK

SIGNAL EQUIPMENT LEGEND	
	TRAFFIC SIGNAL MAST ARM OR PEDESTRIAN SIGNAL BASE
	TRAFFIC SIGNAL HEAD
	PEDESTRIAN SIGNAL

NOTE: 1. BASE PLAN INFORMATION OBTAINED FROM CAMBRIDGE. G.I.S. AND FIELD INVENTORIES CONDUCTED BY VAI MARCH 2020.

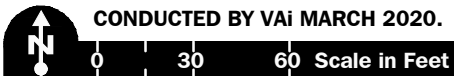


Figure 1.b.2
Intersection Inventory
O'Brien Highway at Cambridge Street
and East Street



SIGN LEGEND (ARROW DIRECTION ON SIGNAGE VARIES BASED ON LOCATION)

SPEC. 2 (MOD.)		SPEC. 5		SPEC. 6A		R1-1		R7-7			
R7-108a		R8-5a		R8-5b		R10-11a				R2-9A	
W1-4L		SPEC. 8		<p>MARKING LEGEND</p> <p>DYCL — DOUBLE YELLOW CENTER LINE SWEL — SOLID WHITE EDGE LINE SWLL — SOLID WHITE LANE LINE SL — STOP LINE</p>							

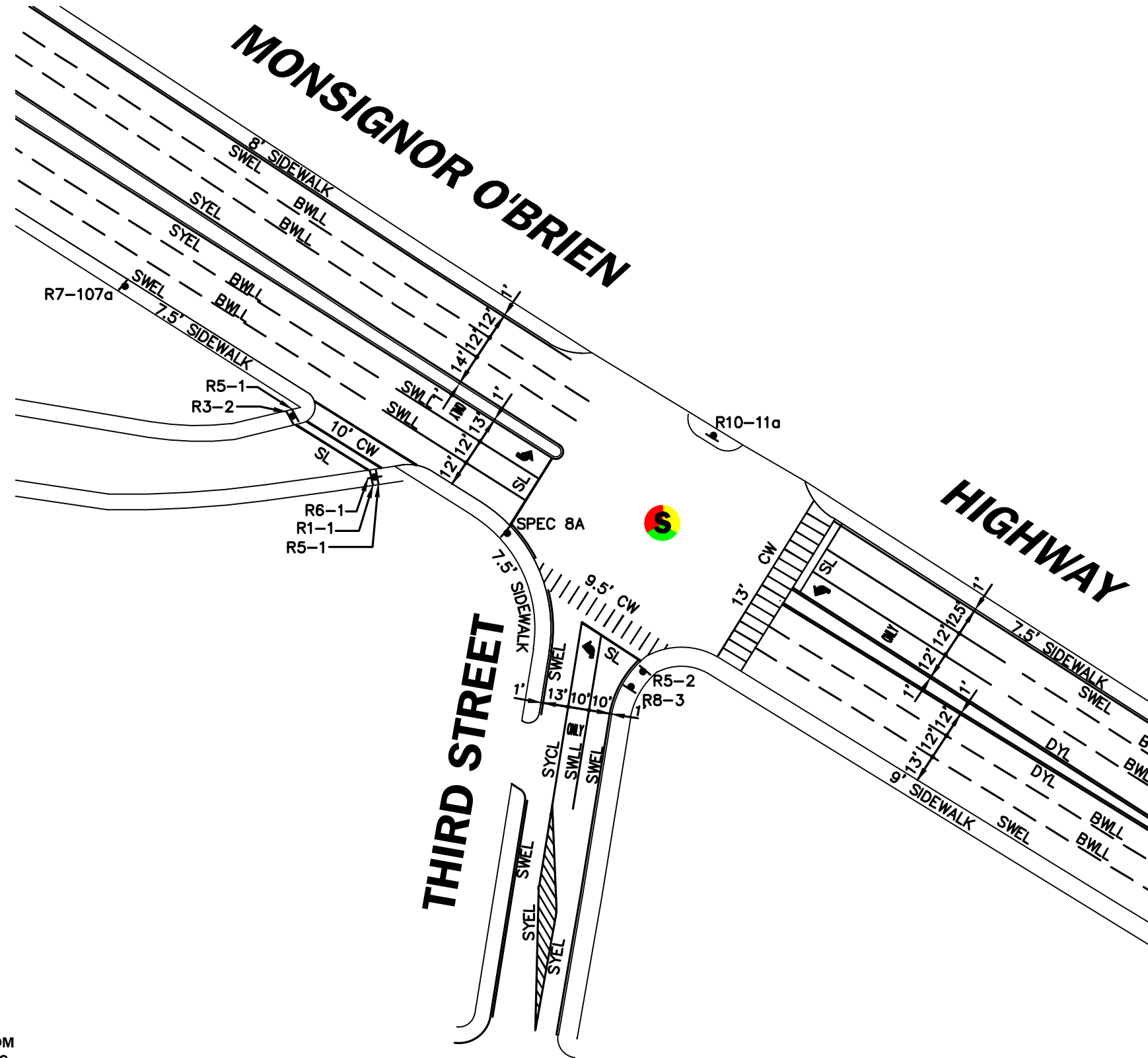
Source: Cambridge Development Map and Field Inventory conducted by VAI, March 2020.



Figure 1.b.3



Intersection Inventories
Cambridge Street at First Street



SIGN LEGEND					
R1-1		R5-1		R7-107a	
R3-1		R5-2		R10-11a	
R3-1		R6-1		SPEC. 8A	
R4-7		R8-3			

SIGN LEGEND
BWLL — BROKEN WHITE LANE LINE
DYCL — DOUBLE YELLOW CENTER LINE
SYCL — SOLID YELLOW CENTER LINE
DYL — DOUBLE YELLOW LINE
SWEL — SOLID WHITE EDGE LINE
SYEL — SOLID YELLOW EDGE LINE
SYLL — SOLID YELLOW LANE LINE
SWLL — SOLID WHITE LANE LINE
SYGL — SOLID YELLOW GORE LINE
SL — STOP LINE
CW — CROSS WALK

NOTE: 1. BASE PLAN INFORMATION OBTAINED FROM CAMBRIDGE. G.I.S. AND FIELD INVENTORIES CONDUCTED BY VAI MARCH 2020.

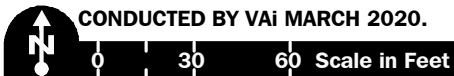


Figure 1.b.4

Intersection Inventories
O'Brien Highway at Third Street



SIGN LEGEND (ARROW DIRECTION ON SIGNAGE VARIES BASED ON LOCATION)

SPEC. 2		SPEC. 2A		SPEC. 3		SPEC. 5		R5-2		R7-5	
R7-6		R10-6		R7-107a		R7-108a		R8-5a		R8-5b	

MARKING LEGEND

DYCL — DOUBLE YELLOW CENTER LINE
 SWEL — SOLID WHITE EDGE LINE
 SWLL — SOLID WHITE LANE LINE
 SL — STOP LINE



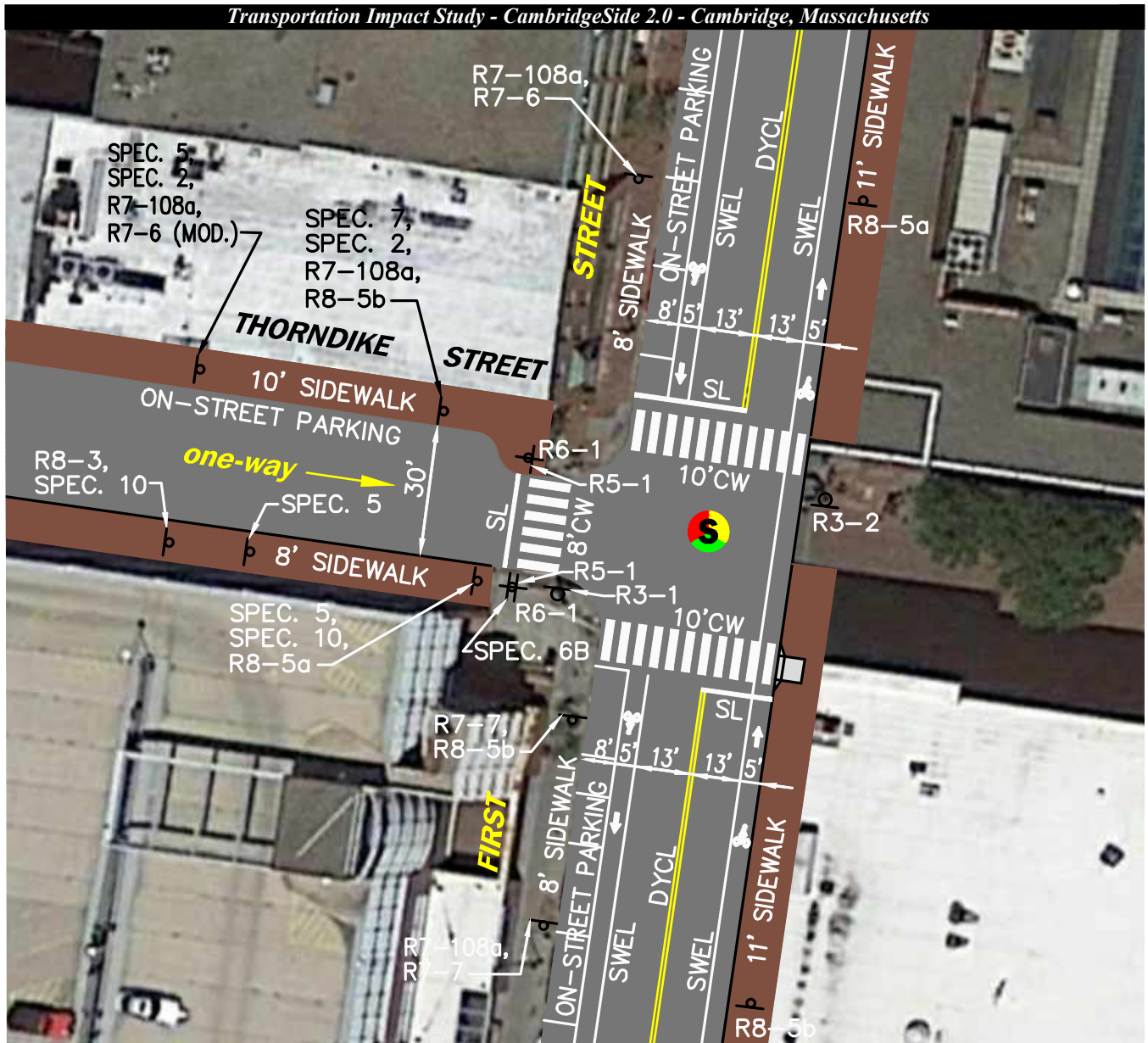
Source: Cambridge Development Map and Field Inventory conducted by VAI, March 2020.

0 20 40 Scale in Feet

Figure 1.b.5



Intersection Inventories
 Cambridge Street at Third Street



SIGN LEGEND (ARROW DIRECTION ON SIGNAGE VARIES BASED ON LOCATION)

SPEC. 2		SPEC. 3		SPEC. 4		SPEC. 5		SPEC. 6B		SPEC. 7	
SPEC. 10		R1-1		R3-1		R3-2		R5-1		R6-1	
R7-6		R7-6 (MOD.)		R7-7		R7-108a		R8-3		R8-5a	
										R8-5b	

MARKING LEGEND

DYCL — DOUBLE YELLOW CENTER LINE SWEL — SOLID WHITE EDGE LINE SL — STOP LINE

Source: Cambridge Development Map and Field Inventory conducted by VAI, March 2020.

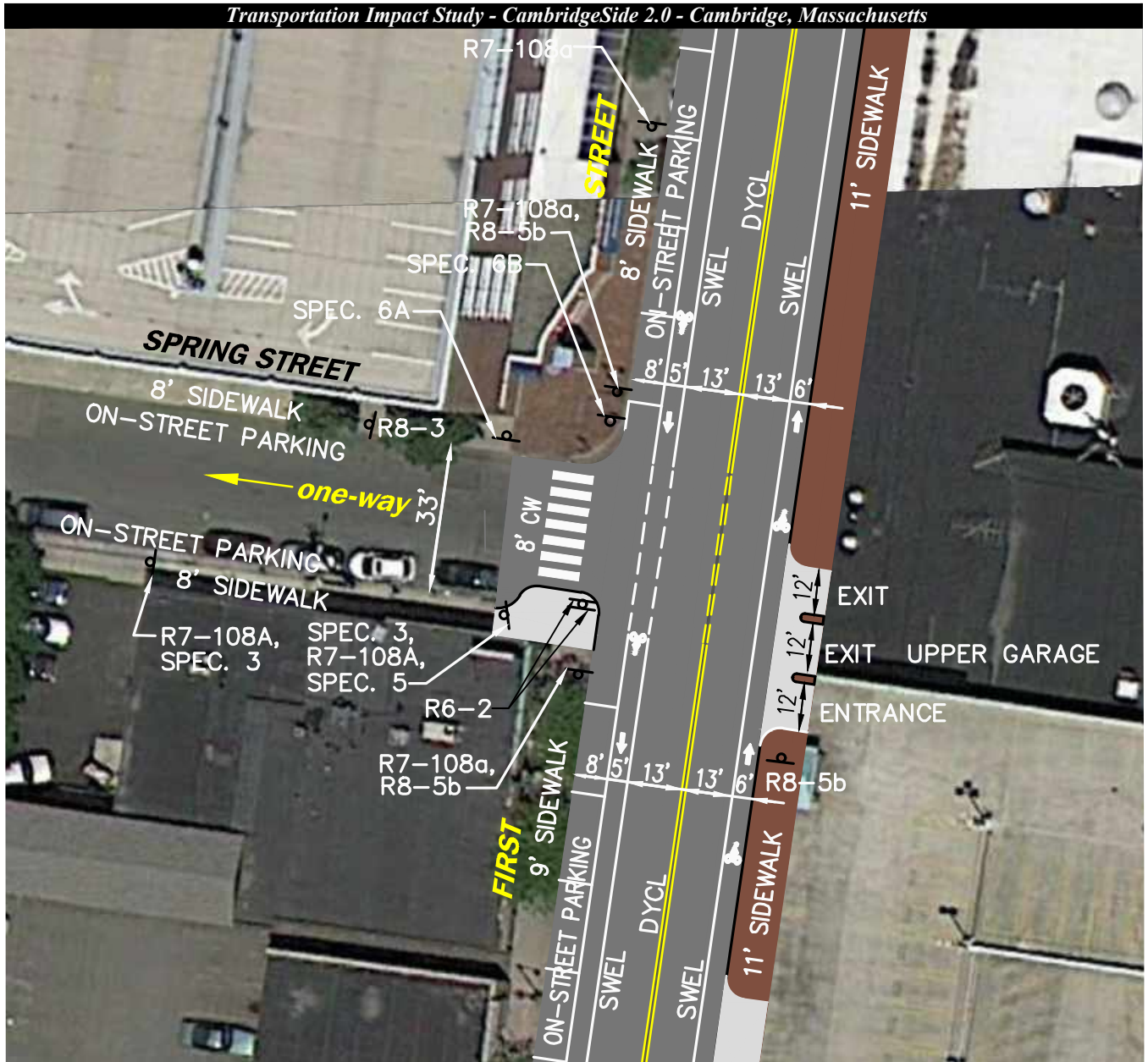


0 20 40 Scale in Feet

Figure 1.b.6



Intersection Inventories
First Street at Thorndike Street



SIGN LEGEND (ARROW DIRECTION ON SIGNAGE VARIES BASED ON LOCATION)

SPEC. 3		SPEC. 5		SPEC. 6A		SPEC. 6B		R6-1		R6-2	
		R7-108a		R8-3		R8-5b					

MARKING LEGEND

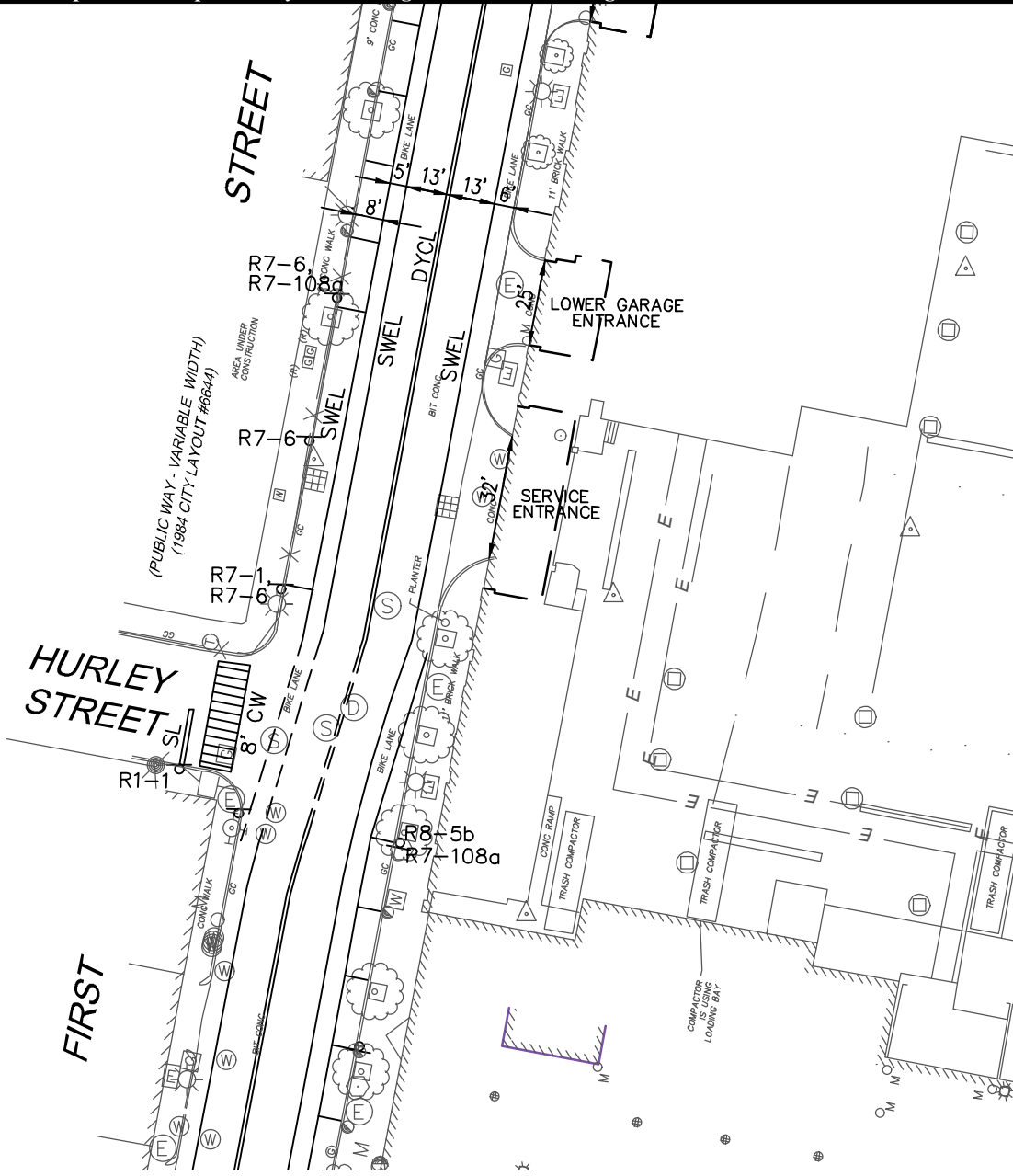
DYCL — DOUBLE YELLOW CENTER LINE
SWEL — SOLID WHITE EDGE LINE

Source: Cambridge Development Map and Field Inventory conducted by VAI, March 2020. Figure 1.b.7



**Intersection Inventories
First Street at Spring Street and
Upper Garage Entrance and Exit**

R:\7810\TIS\7810INVENTORY1.dwg, 3/23/2020 12:17:00 PM



SIGN LEGEND (ARROW DIRECTION ON SIGNAGE VARIES BASED ON LOCATION)									
R1-1		R7-1		R7-6		R8-5b		R7-108a	

MARKING LEGEND	
SWEL	SOLID WHITE EDGE LINE
SL	STOP LINE
CW	CROSSWALK



Source: TetraTech, BSC Group, Cambridge Development Map and Field Inventory conducted by VAI, March 2020.

0 25 50 Scale in Feet

Figure 1.b.8



**Intersection Inventories
First Street at Lower Garage
Entrance and Service Entrance**



SIGN LEGEND (ARROW DIRECTION ON SIGNAGE VARIES BASED ON LOCATION)

SPEC. 2		SPEC. 5		R3-1		R3-2		R6-1		R5-1	
R7-2		R7-5		R7-6		R7-8		R7-108a		R7-108b	
R8-3		R8-5a		R8-5b		R10-11a		W1-4L			

MARKING LEGEND

DYCL — DOUBLE YELLOW CENTER LINE SWEL — SOLID WHITE EDGE LINE CW — CROSSWALK SL — STOP LINE

Source: Cambridge Development Map and Field Inventory conducted by VAI, March 2020.

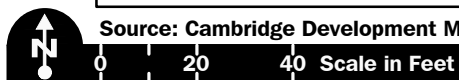
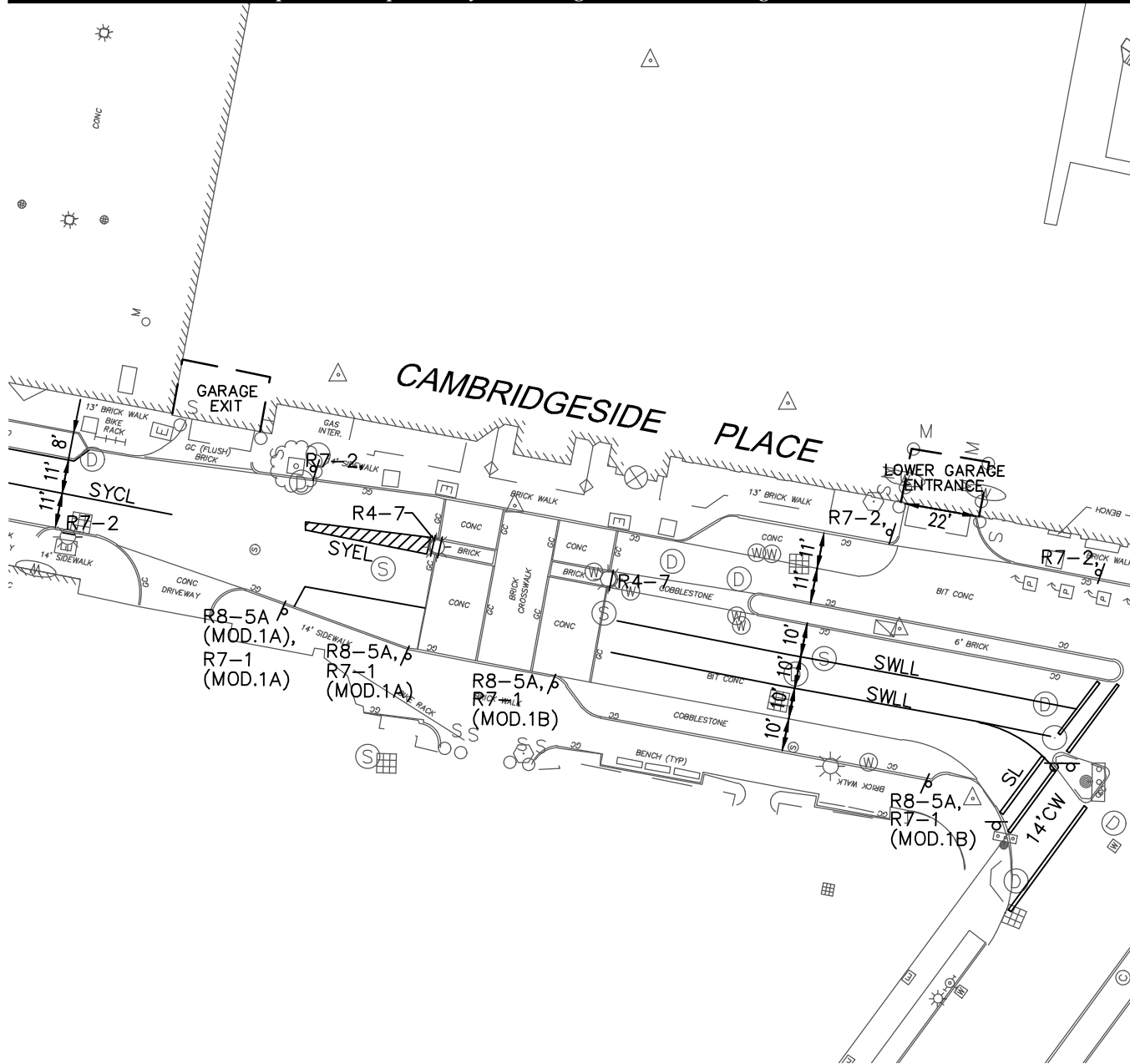


Figure 1.b.9



Intersection Inventories
First Street at Cambridgeside
Place and Charles Street



SIGN LEGEND (ARROW DIRECTION ON SIGNAGE VARIES BASED ON LOCATION)											
R4-7		R7-1 (MOD. 1A)		R7-1 (MOD. 1B)		R7-2		R8-5a		R8-5a (MOD. 1A)	

MARKING LEGEND
SWEL — SOLID WHITE EDGE LINE
SWLL — SOLID WHITE LANE LINE
SYCL — SOLID YELLOW CENTER LINE
SL — STOP LINE
CW — CROSSWALK

Source: TetraTech, BSC Group, Cambridge Development Map and Field Inventory conducted by VAI, March 2020. **Figure 1.b.10**



**Intersection Inventories
Cambridgeside Place at
Lower Garage Entrance and Exit**



SIGN LEGEND (ARROW DIRECTION ON SIGNAGE VARIES BASED ON LOCATION)

R1-1		R3-4		R4-7		R3-7L	LEFT LANE MUST TURN LEFT	R7-1		R7-2	
				R7-1 (MOD. 1)		R8-5a					

MARKING LEGEND	
SWEL	SOLID WHITE EDGE LINE
SWLL	SOLID WHITE LANE LINE
SYEL	SOLID YELLOW EDGE LINE
SL	STOP LINE

Source: Cambridge Development Map and Field Inventory conducted by VAI, March 2020.

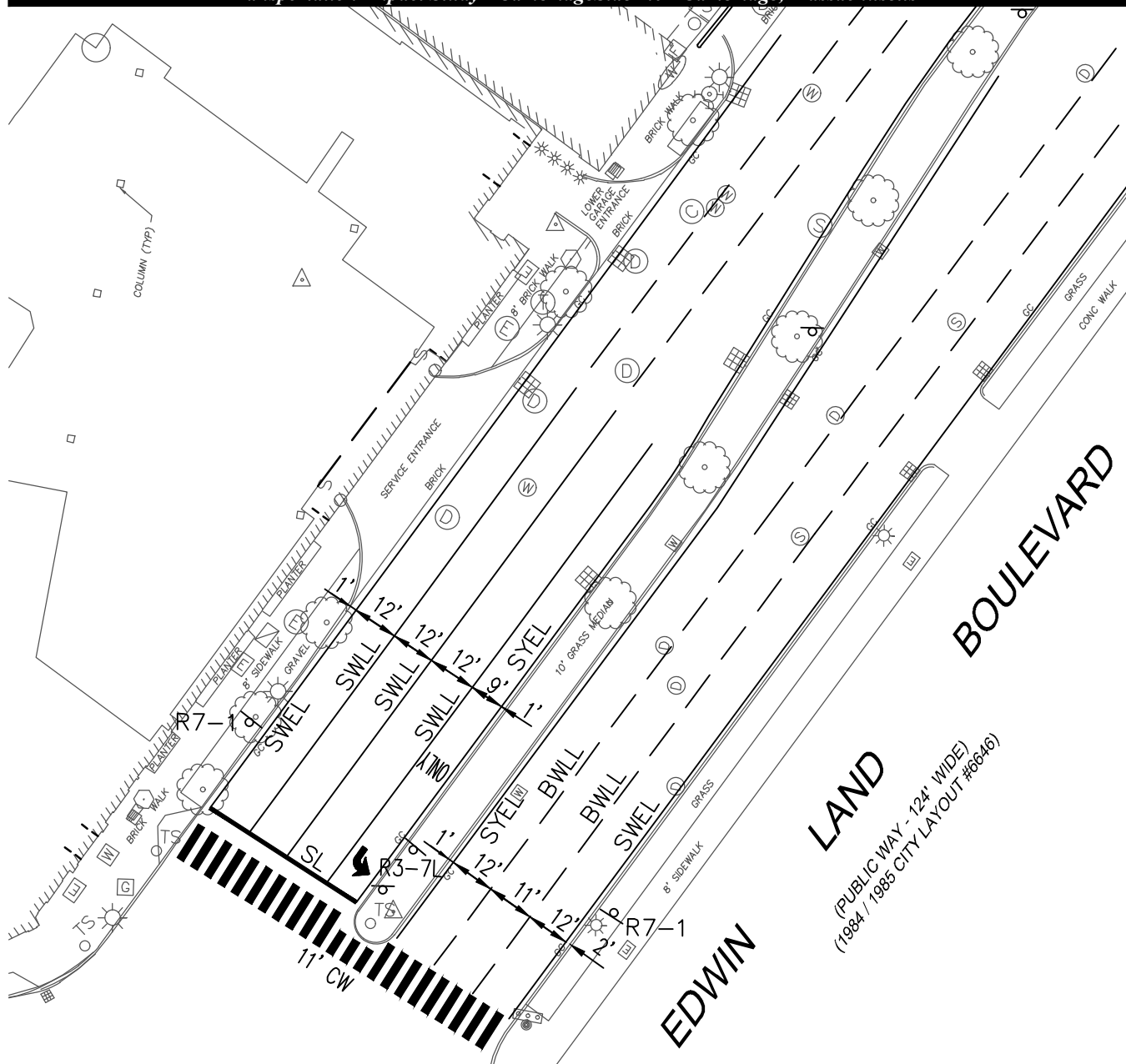
0 20 40 Scale in Feet

Figure 1.b.11



**Intersection Inventories
Land Boulevard at
Cambridgeside Place**

R:\7810\TIS\7810INVENTORY1.dwg, 3/23/2020 12:21:07 PM



SIGN LEGEND (ARROW DIRECTION ON SIGNAGE VARIES BASED ON LOCATION)			
R3-7L	LEFT LANE MUST TURN LEFT	R7-1	TOW ZONE NO PARKING ANYTIME

MARKING LEGEND
SWEL — SOLID WHITE EDGE LINE
SWLL — SOLID WHITE LANE LINE
SYEL — SOLID YELLOW EDGE LINE
SL — STOP LINE

Source: TetraTech, BSC Group, Cambridge Development Map and Field Inventory conducted by VAI, March 2020. **Figure 1.b.12**



**Intersection Inventories
Land Boulevard at Service
Entrance and Lower Garage
Entrance**



SIGN LEGEND (ARROW DIRECTION ON SIGNAGE VARIES BASED ON LOCATION)

R3-4		R3-7R	RIGHT LANE MUST TURN RIGHT	R3-7DL		R4-7		R7-1		R8-5a	
R8-5b		R12-5	WEIGHT LIMIT 12T 17T 28T	R14-2		M6-1		SPEC. 11			

MARKING LEGEND

- DYCL — DOUBLE YELLOW CENTER LINE
- SWEL — SOLID WHITE EDGE LINE
- SWLL — SOLID WHITE LANE LINE
- SYEL — SOLID YELLOW EDGE LINE
- SL — STOP LINE



Source: Cambridge Development Map and Field Inventory conducted by VAI, March 2020.

0 20 40 Scale in Feet

Figure 1.b.13



Intersection Inventories
Binney Street at Land Boulevard



SIGN LEGEND (ARROW DIRECTION ON SIGNAGE VARIES BASED ON LOCATION)											
SPEC. 5		SPEC. 6B		R3-7L		R3-2		R3-7R		R3-17	
R4-7		R7-6		R7-108a		R8-5a		R8-5b		R10-11a	
R10-15		<p>MARKING LEGEND</p> <p>BWLL — BROKEN WHITE LANE LINE DYCL — DOUBLE YELLOW CENTER LINE SWEL — SOLID WHITE EDGE LINE SWLL — SOLID WHITE LANE LINE SL — STOP LINE</p>									

Source: Google Earth and Field Inventory conducted by VAI, March 2020.

0 20 40 Scale in Feet

Figure 1.b.14



Intersection Inventories
Binney Street at First Street

R:\7810\TIS\7810INVENTORY4.dwg, 3/20/2020 2:26:20 PM



SIGN LEGEND (ARROW DIRECTION ON SIGNAGE VARIES BASED ON LOCATION)

SPEC-1		SPEC. 2		SPEC. 5		R3-5L		R3-7L		R4-7	
R5-2		R7-5		R7-108a		R8-5a		R8-5b		R10-11a	

MARKING LEGEND

DYCL — DOUBLE YELLOW CENTER LINE
 SWEL — SOLID WHITE EDGE LINE
 SWLL — SOLID WHITE LANE LINE
 SYEL — SOLID YELLOW EDGE LINE
 SL — STOP LINE

Source: Google Earth and Field Inventory conducted by VAI, March 2020.

Figure 1.b.15

Intersection Inventories
 Binney Street at Second Street





SIGN LEGEND (ARROW DIRECTION ON SIGNAGE VARIES BASED ON LOCATION)

R3-4		R3-7L	LEFT LANE MUST TURN LEFT	R3-7R	RIGHT LANE MUST TURN RIGHT	R3-17		R4-7		R5-2	
R7-1		R8-5a		R10-11a		SPEC-1					

MARKING LEGEND

DYCL	DOUBLE YELLOW CENTER LINE
SWEL	SOLID WHITE EDGE LINE
SWLL	SOLID WHITE LANE LINE
SYEL	SOLID YELLOW EDGE LINE
SL	STOP LINE



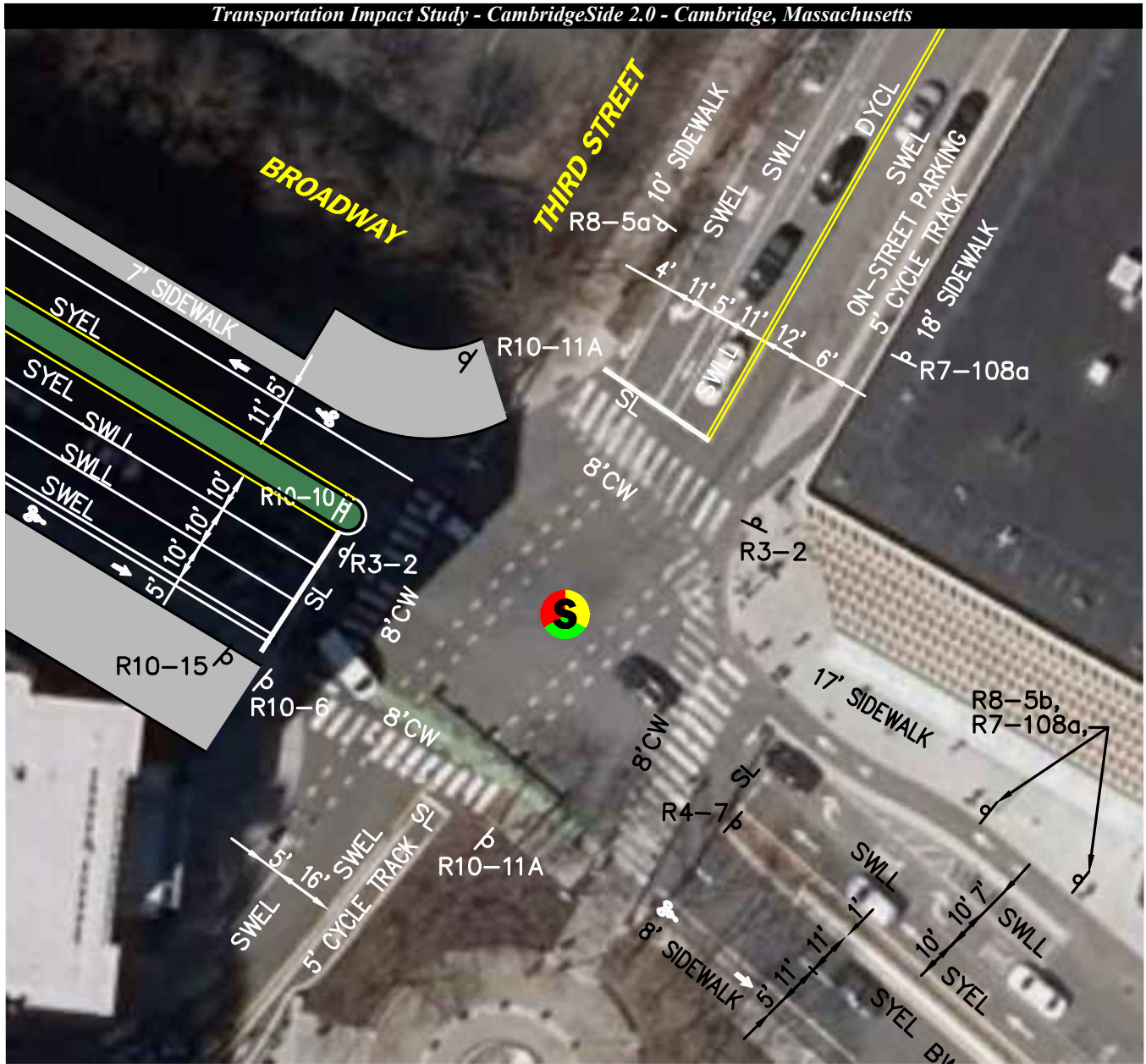
Source: Google Earth and Field Inventory conducted by VAI, March 2020.

0 20 40 Scale in Feet

Figure 1.b.16



Intersection Inventories
Binney Street at Third Street



SIGN LEGEND (ARROW DIRECTION ON SIGNAGE VARIES BASED ON LOCATION)

R3-4		R4-7		R7-8		R7-108a		R8-5a		R8-5b	
R10-6		R10-10		R10-11a		R10-15		SPEC. 3		SPEC. 5	

MARKING LEGEND

- DYCL — DOUBLE YELLOW CENTER LINE
- SWEL — SOLID WHITE EDGE LINE
- SWLL — SOLID WHITE LANE LINE
- SYEL — SOLID YELLOW EDGE LINE
- SL — STOP LINE

Source: Cambridge Development Map and Field Inventory conducted by VAI, March 2020.

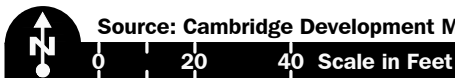
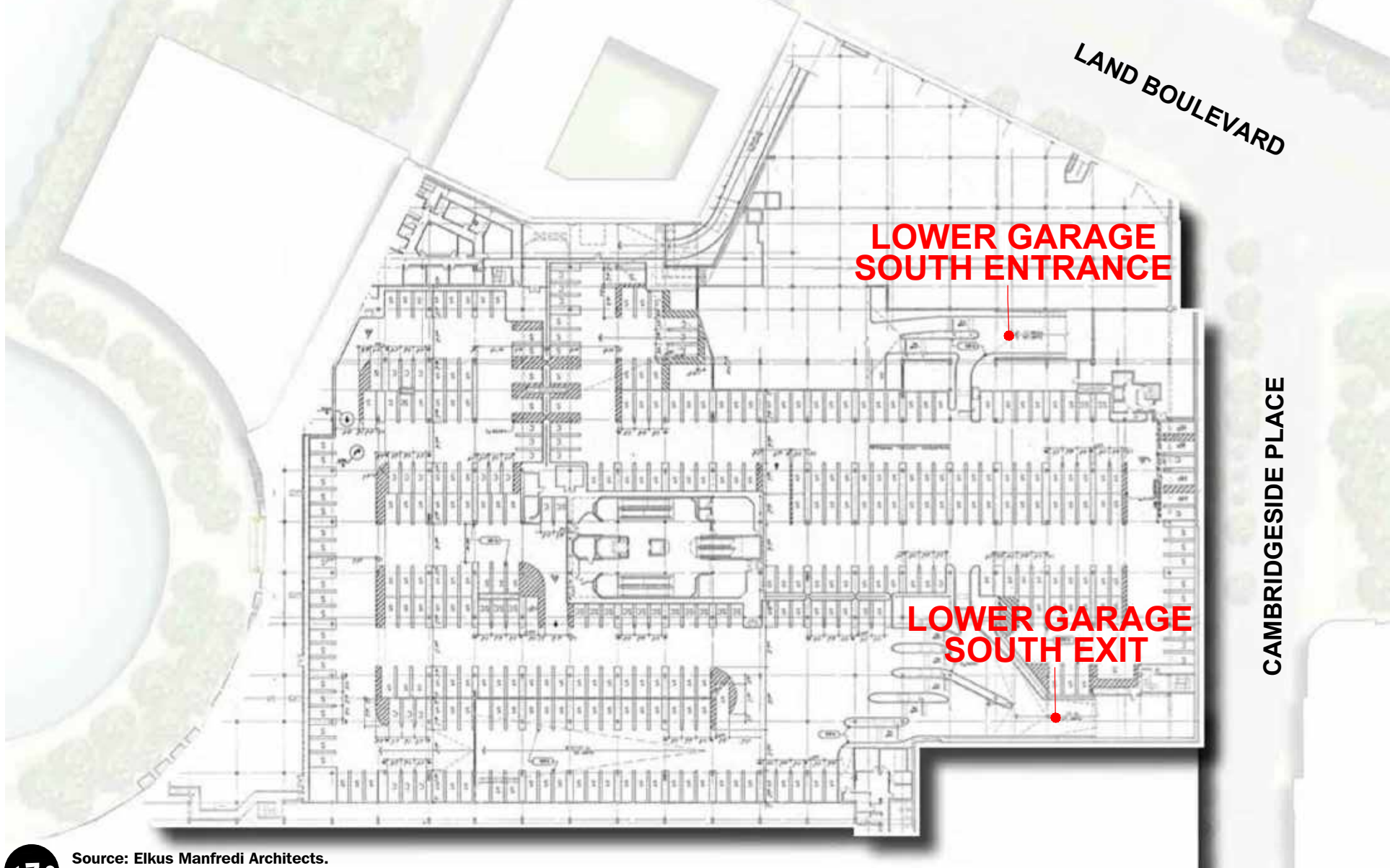


Figure 1.b.17



Intersection Inventories Broadway at Third Street



Source: Elkus Manfredi Architects.

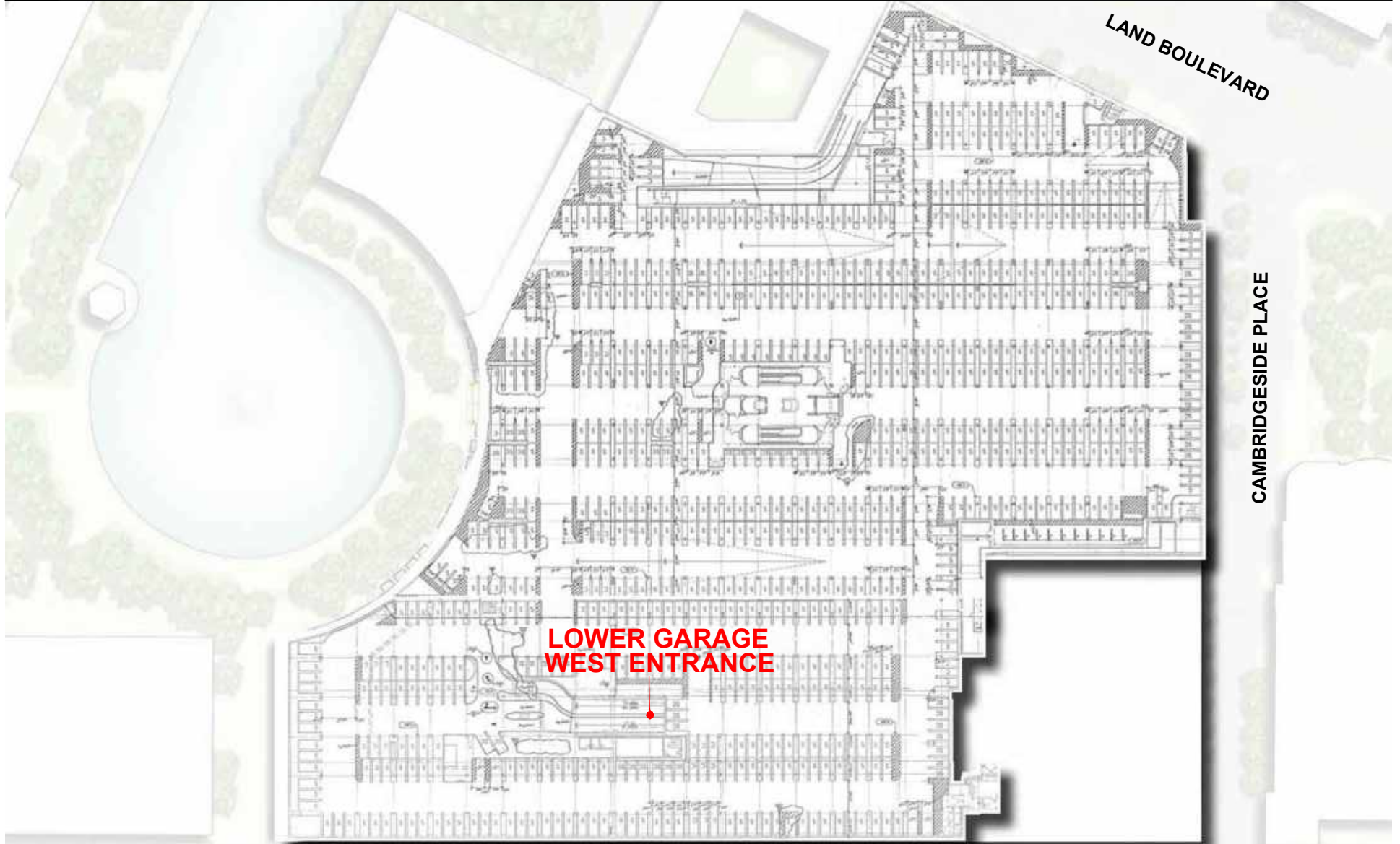
0 85 170 Scale in Feet

Figure 1.c.1

Lower Garage Level G1
Floor Plan



Vanasse &
Associates inc



Source: Elkus Manfredi Architects.
0 110 220 Scale in Feet

Figure 1.c.2

Lower Garage Level G2
Floor Plan



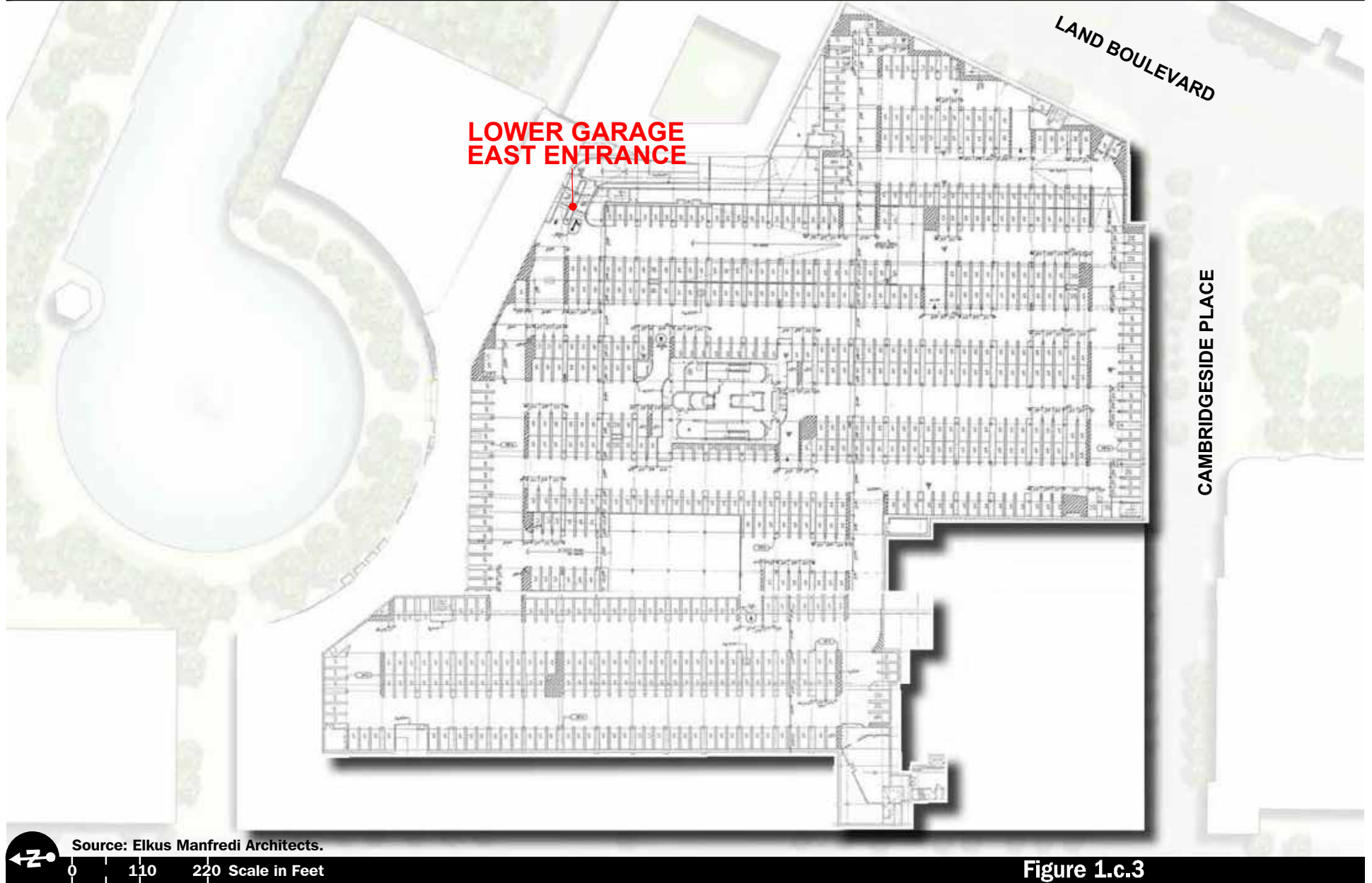
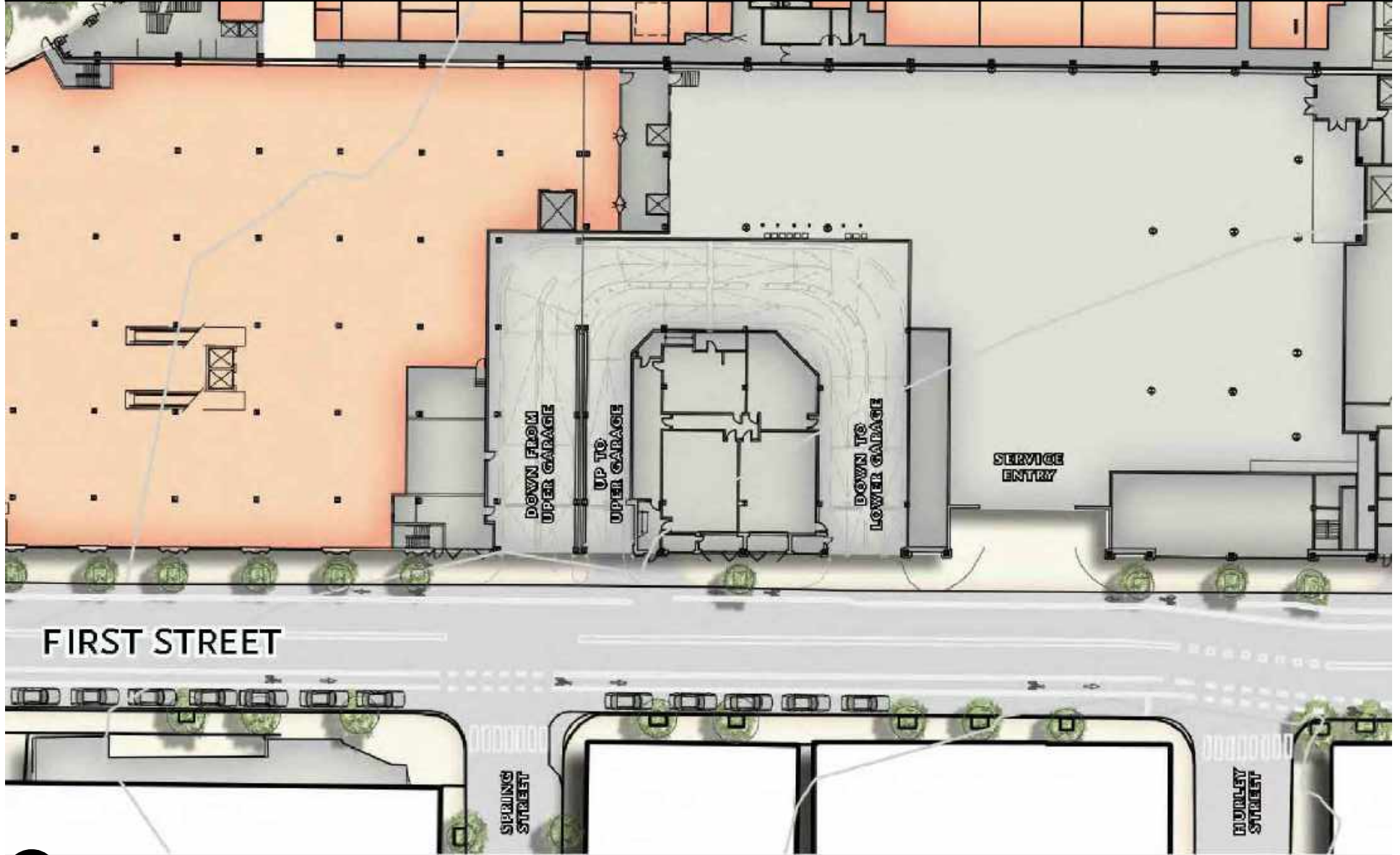


Figure 1.c.3

Lower Garage Level G3
Floor Plan



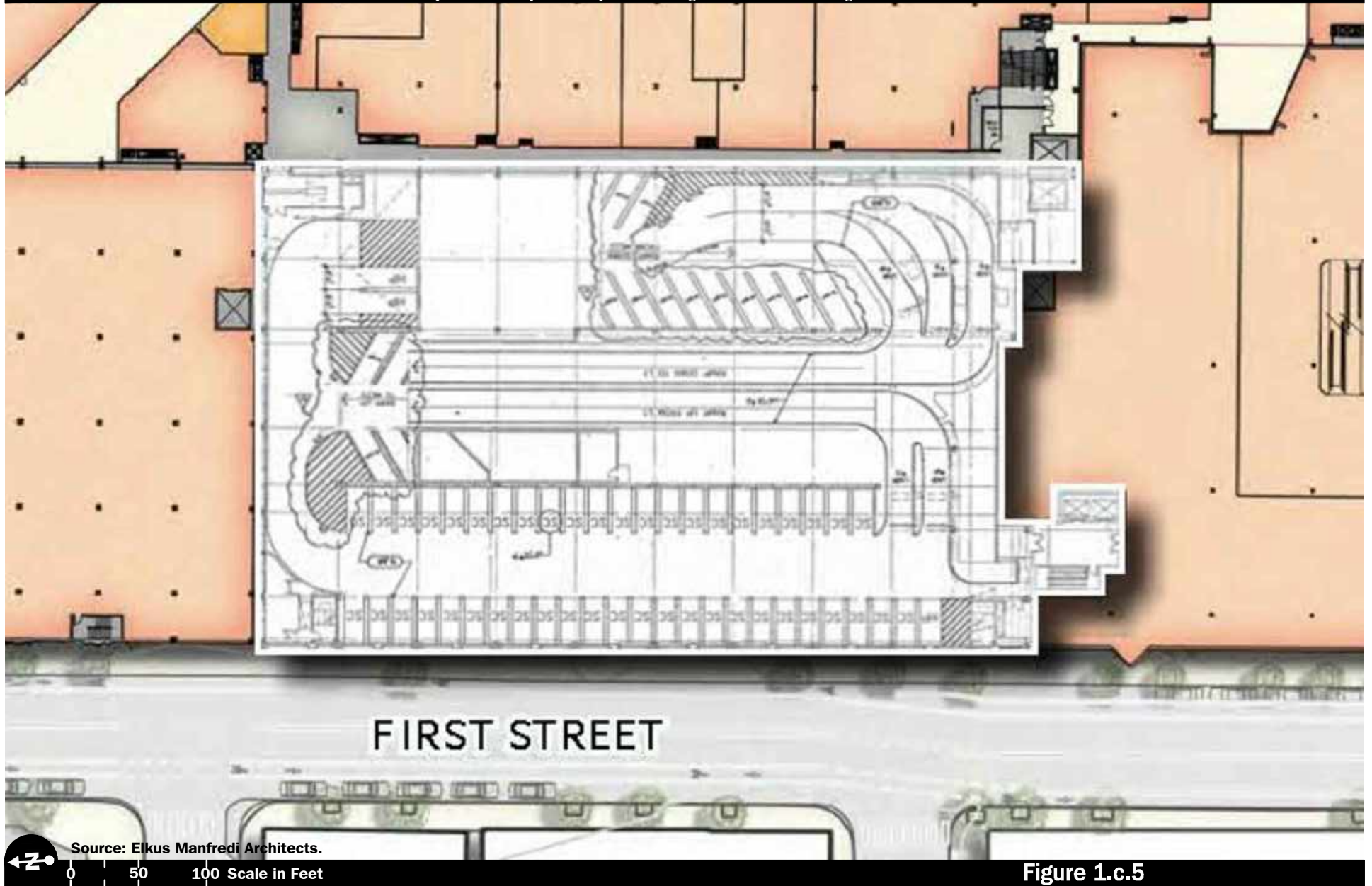


Source: Elkus Manfredi Architects.
0 50 100 Scale in Feet

Figure 1.c.4

Upper Garage Level 1
Floor Plan





Source: Elkus Manfredi Architects.

Figure 1.c.5

Upper Garage Level 2
Floor Plan





Figure 1.c.6

Upper Garage Level 2.5
Floor Plan



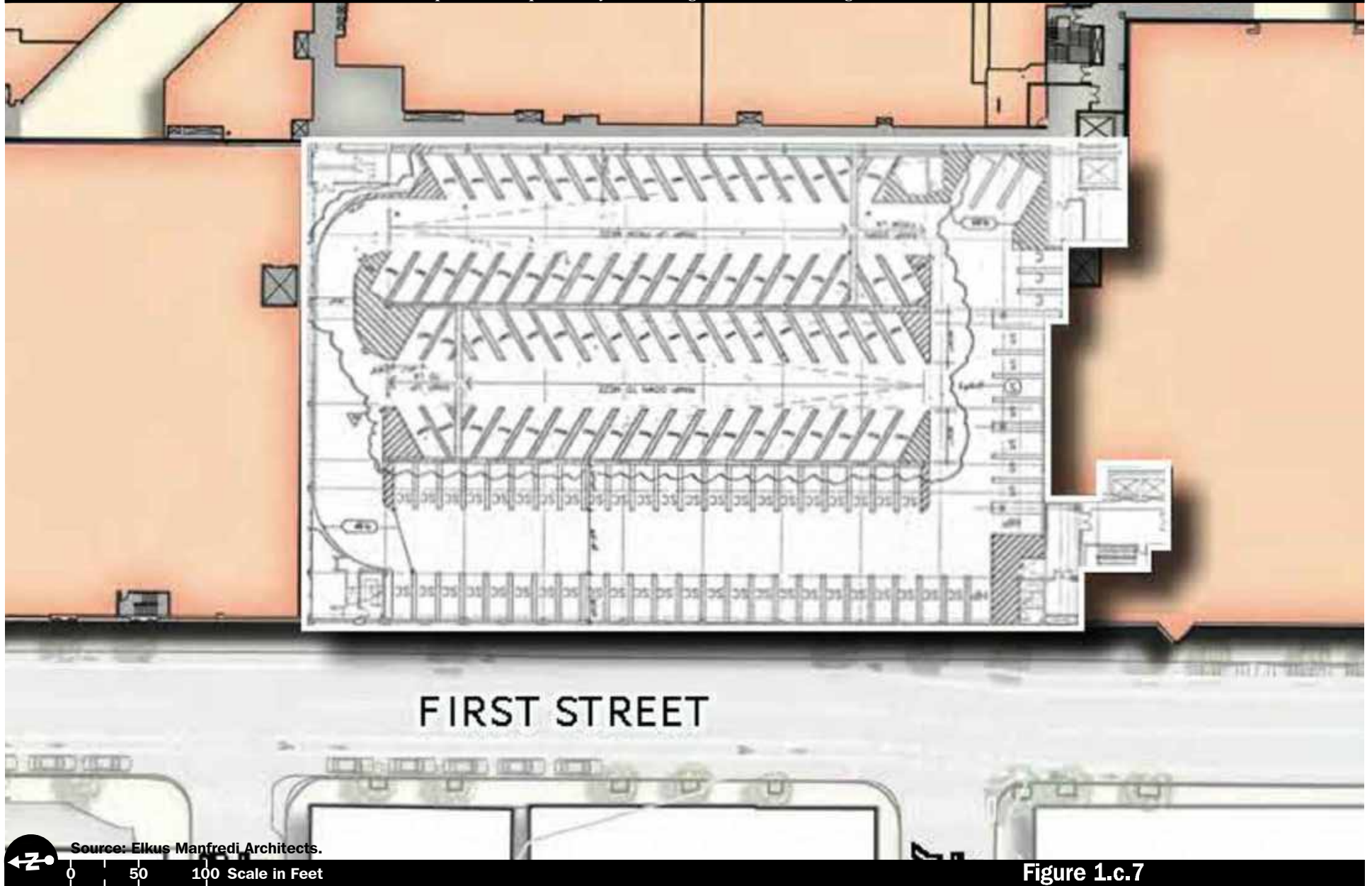


Figure 1.c.7

Upper Garage Level 3
Floor Plan



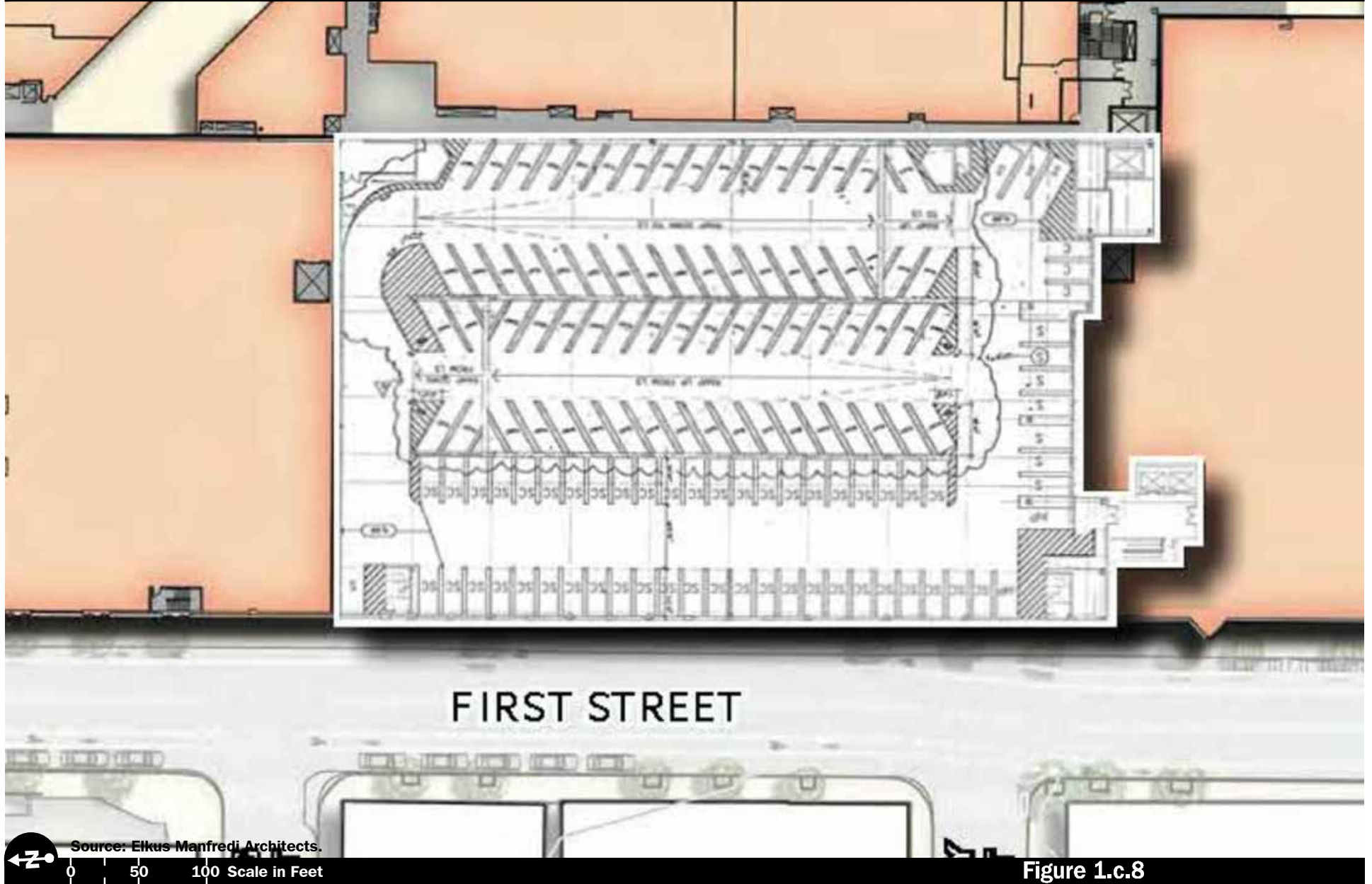
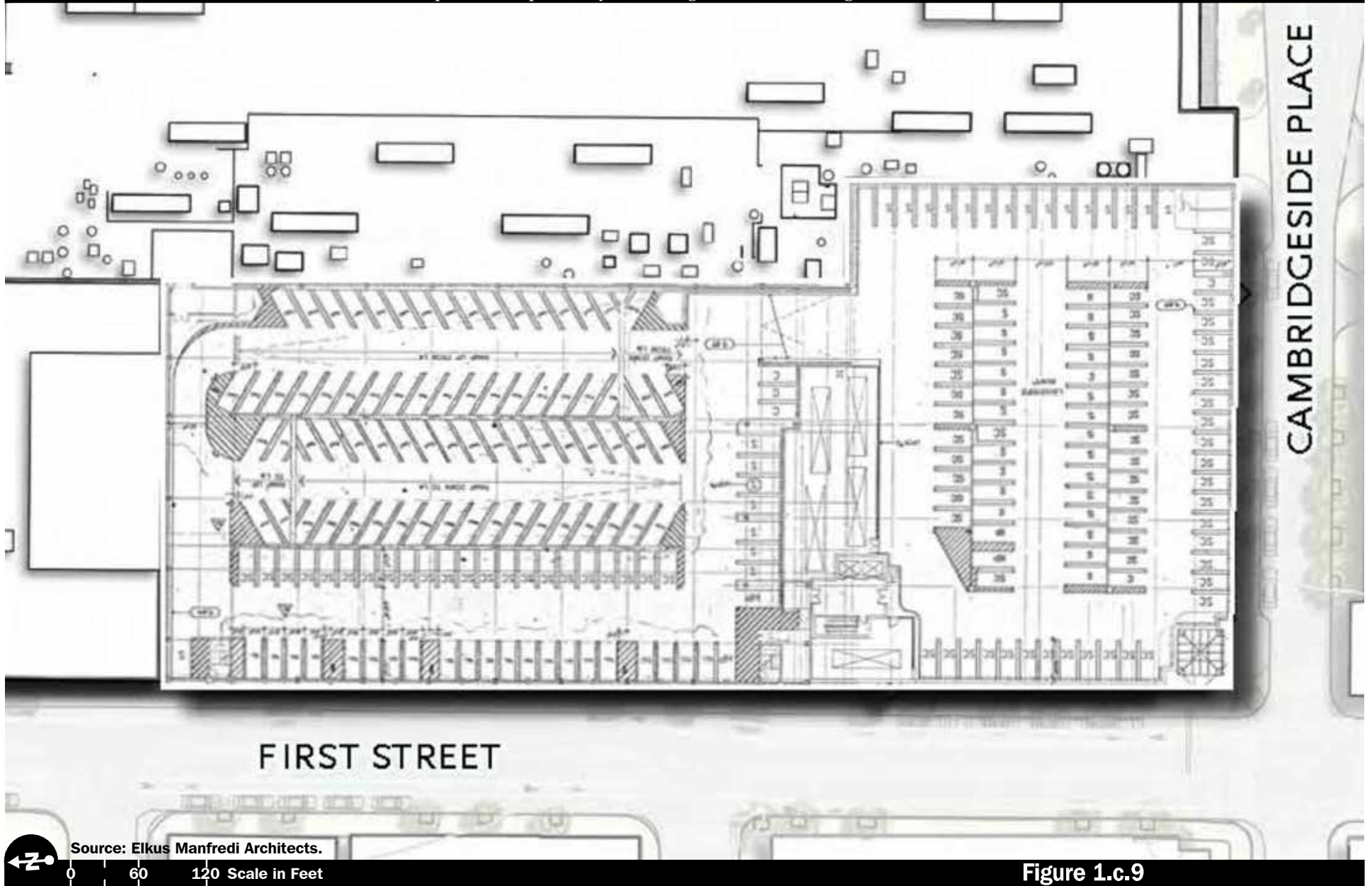


Figure 1.c.8

Upper Garage Level 4
Floor Plan





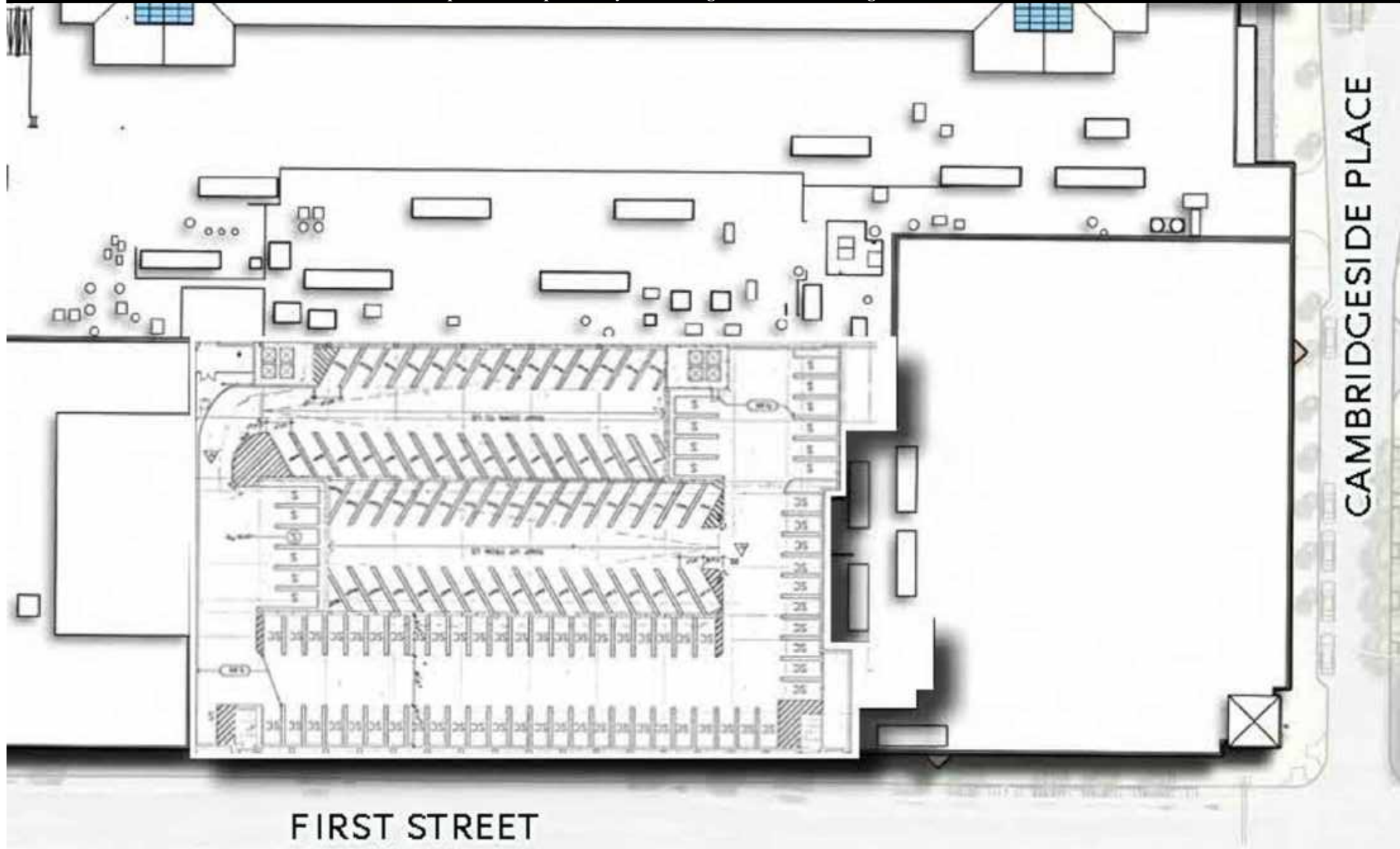
Source: Elkus Manfredi Architects.

0 60 120 Scale in Feet

Figure 1.c.9

Upper Garage Level 5
Floor Plan





FIRST STREET

CAMBRIDGESIDE PLACE

Source: Elkus Manfredi Architects.
0 60 120 Scale in Feet

Figure 1.c.10

Upper Garage Level 6
Floor Plan



R:\7810\Cambridgeside 2.0\7810site.dwg, 4/21/2020 9:15:14 AM

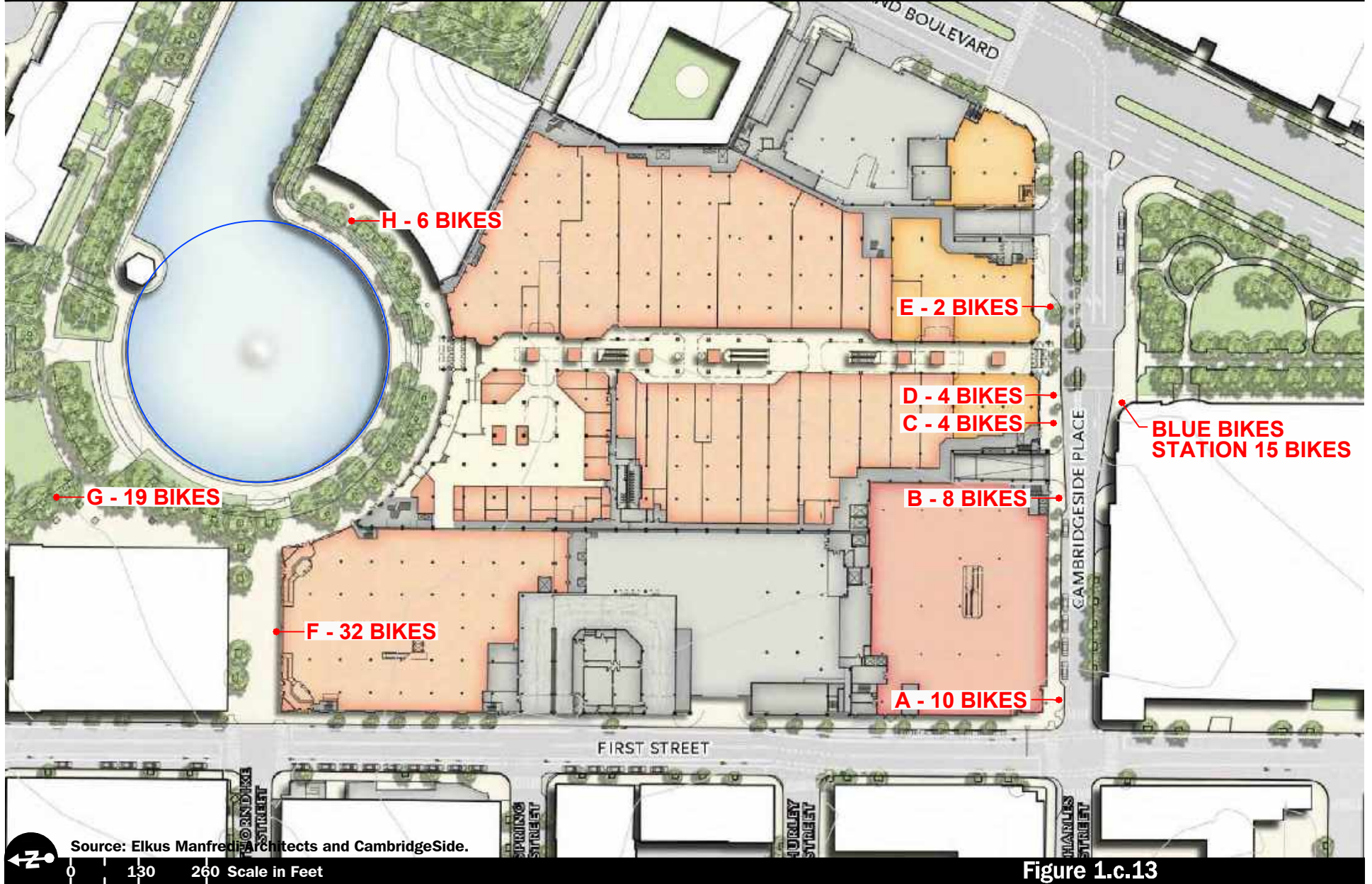
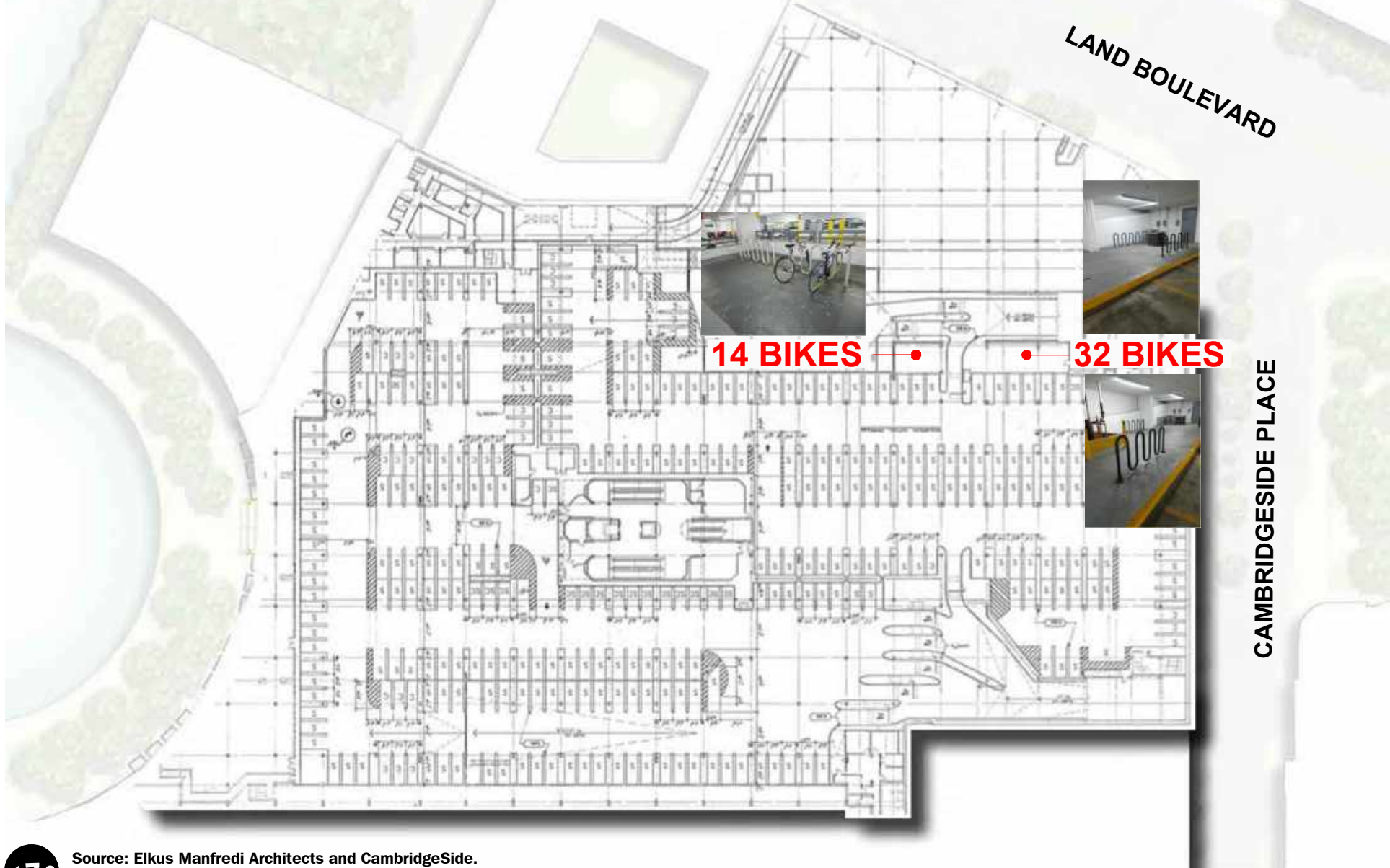


Figure 1.c.13

Existing Short-Term
Bicycle Parking Locations





Source: Elkus Manfredi Architects and CambridgeSide.
0 85 170 Scale in Feet

Figure 1.c.14

Existing Long-Term
Bicycle Parking



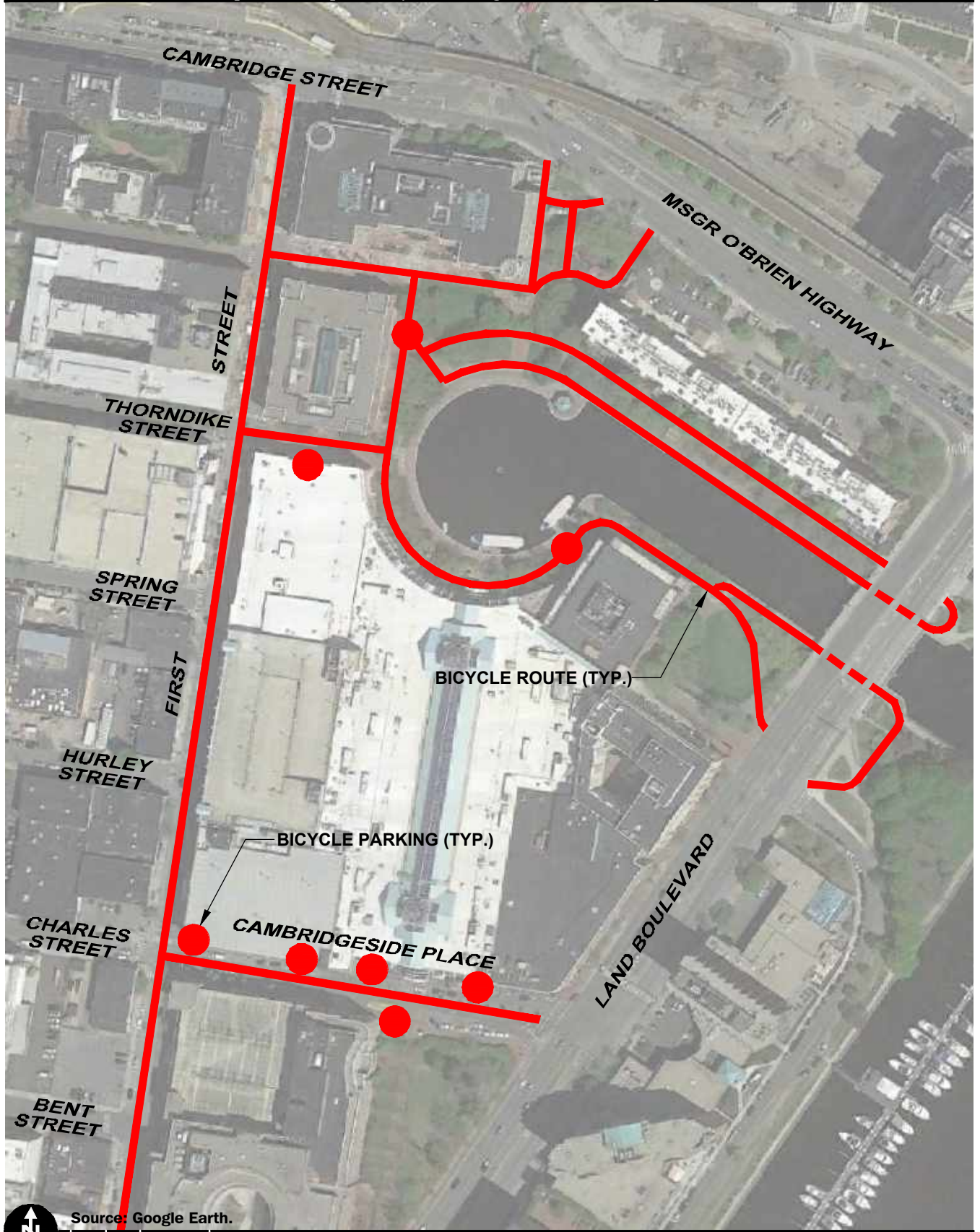


Figure 1.c.15

On-Site Short-Term Bicycle Parking and Access Map



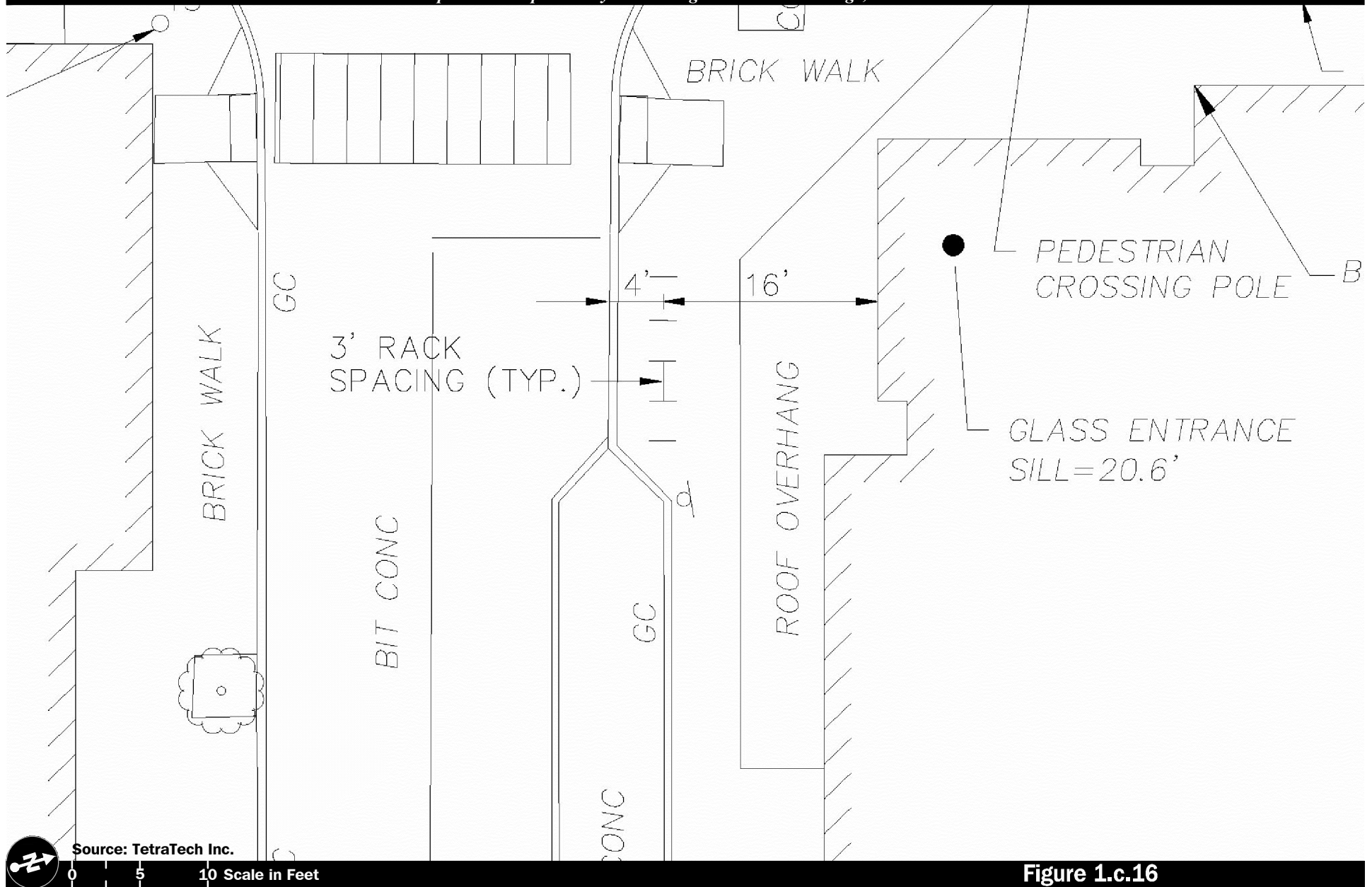


Figure 1.c.16

Location A
Short-Term Bicycle Parking
10 Bicycles



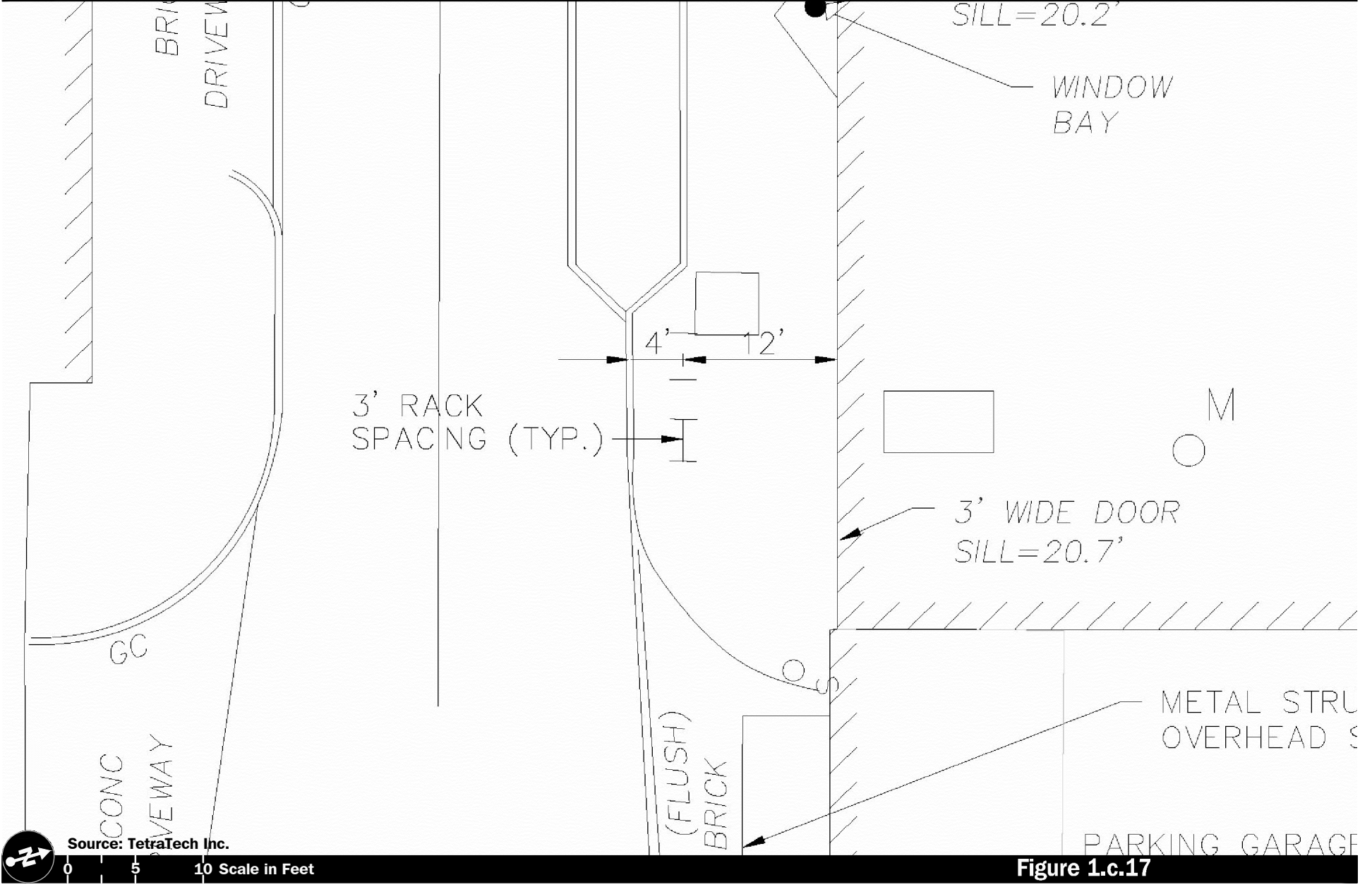


Figure 1.c.17

Location B
Short-Term Bicycle Parking
8 Bicycles



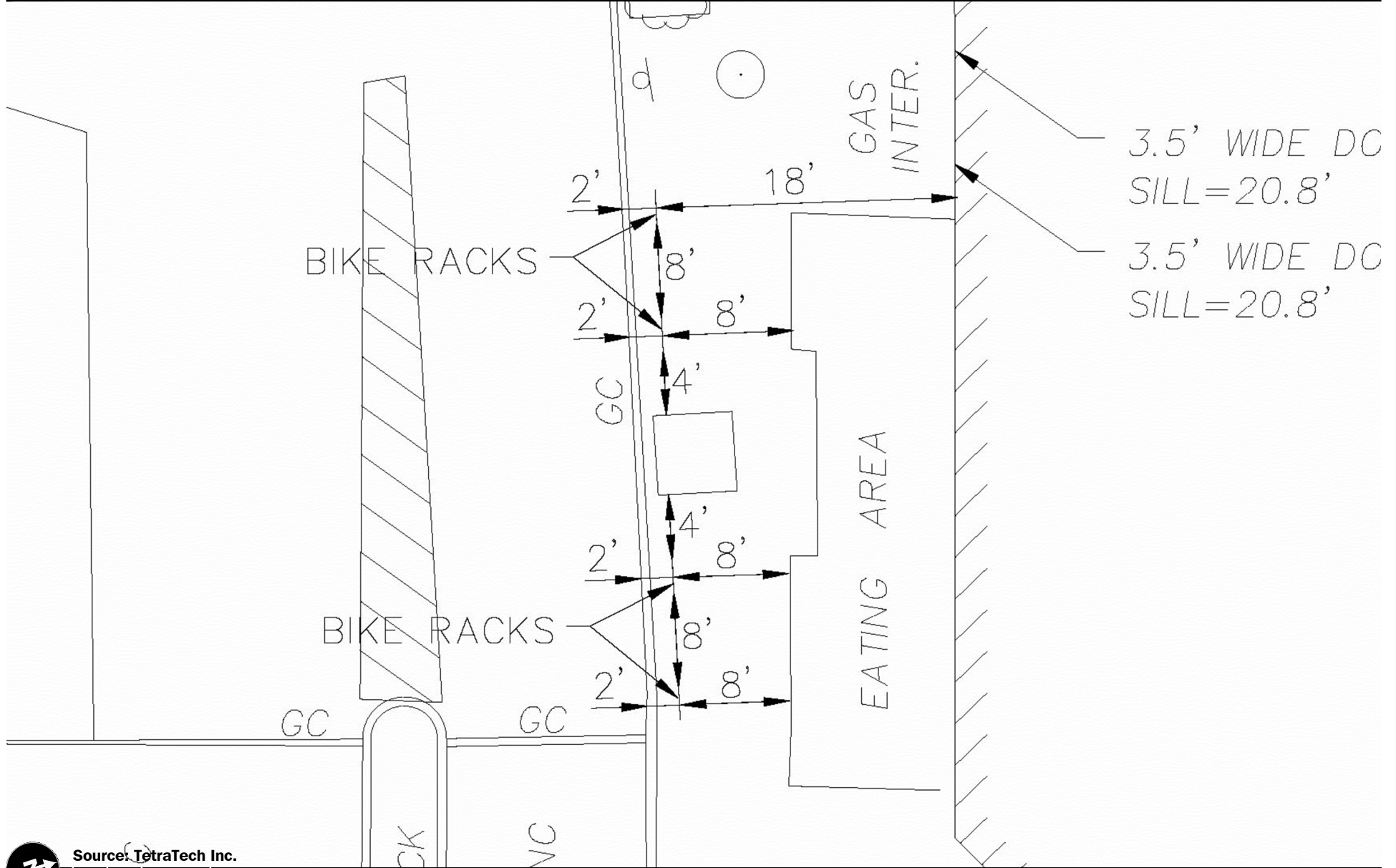
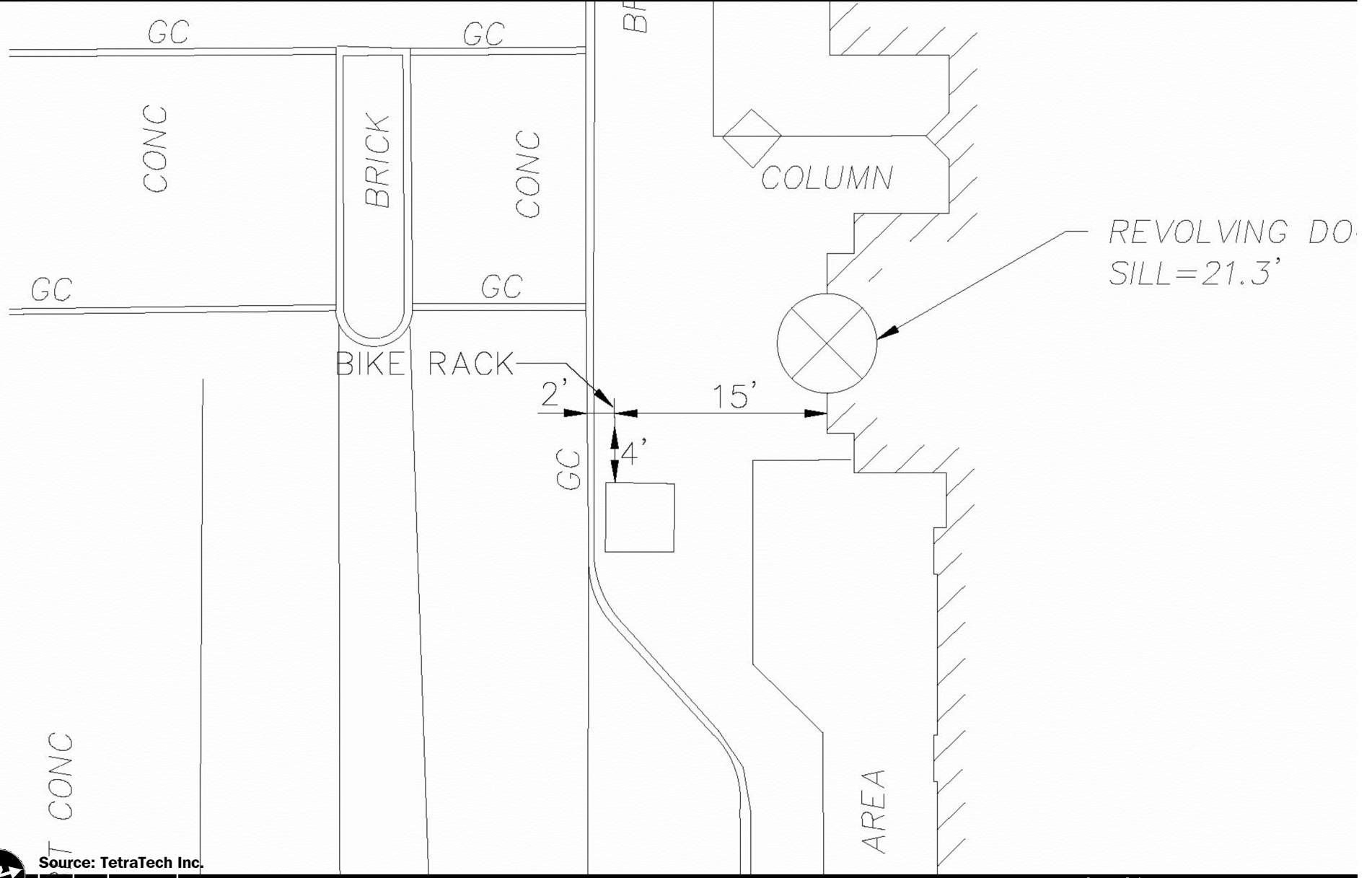


Figure 1.c.18

Locations C and D
Short-Term Bicycle Parking
8 Bicycles

Source: TetraTech Inc.

VAI Vanasse & Associates inc



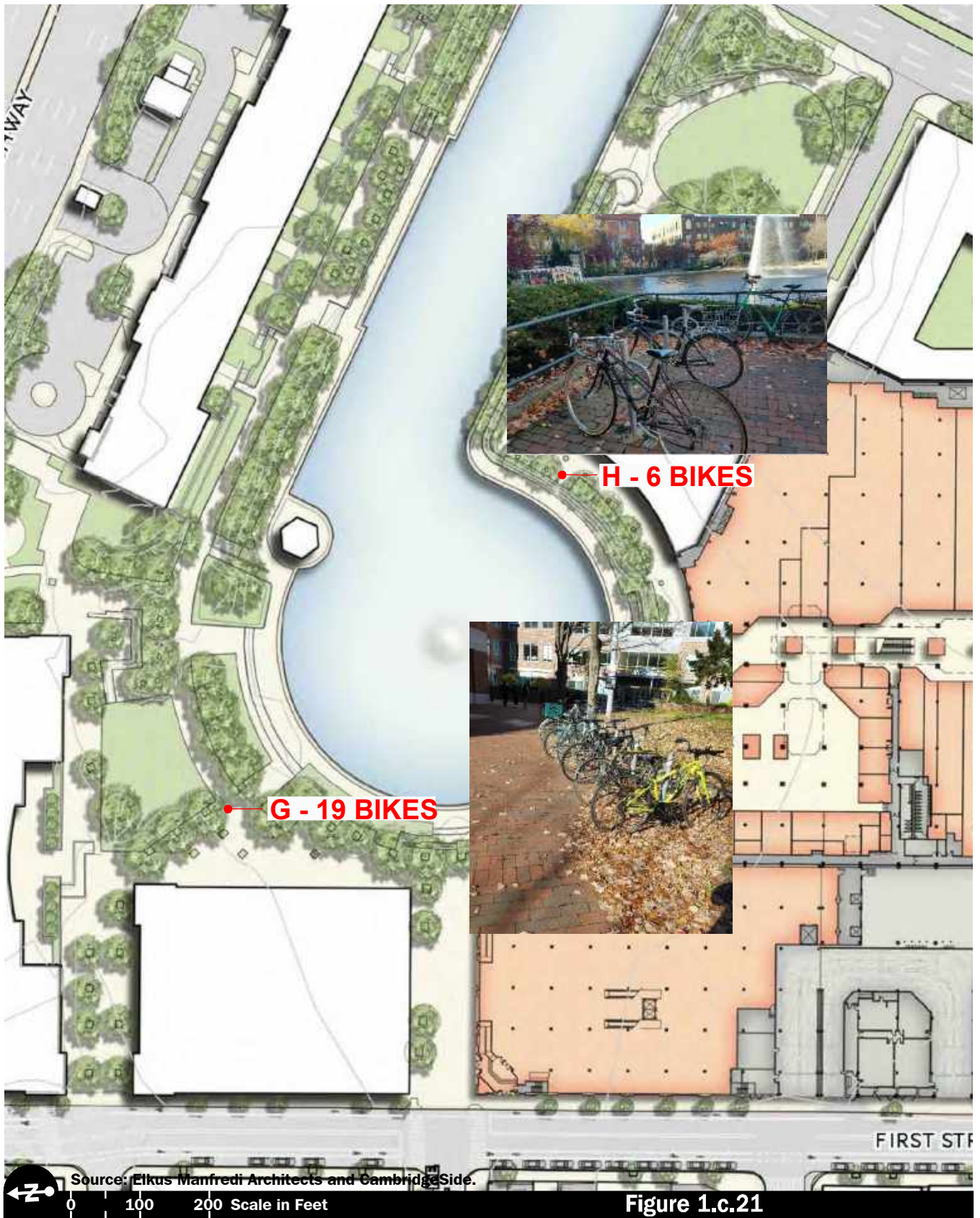
Source: TetraTech Inc.

0 5 10 Scale in Feet



Figure 1.c.19

Location E
Short-Term Bicycle Parking
2 Bicycles



Source: Elkus Manfredi Architects and Cambridge Side.
 0 100 200 Scale in Feet

Figure 1.c.21

**Locations G and H
 Short-Term Bicycle Parking
 25 Bicycles**

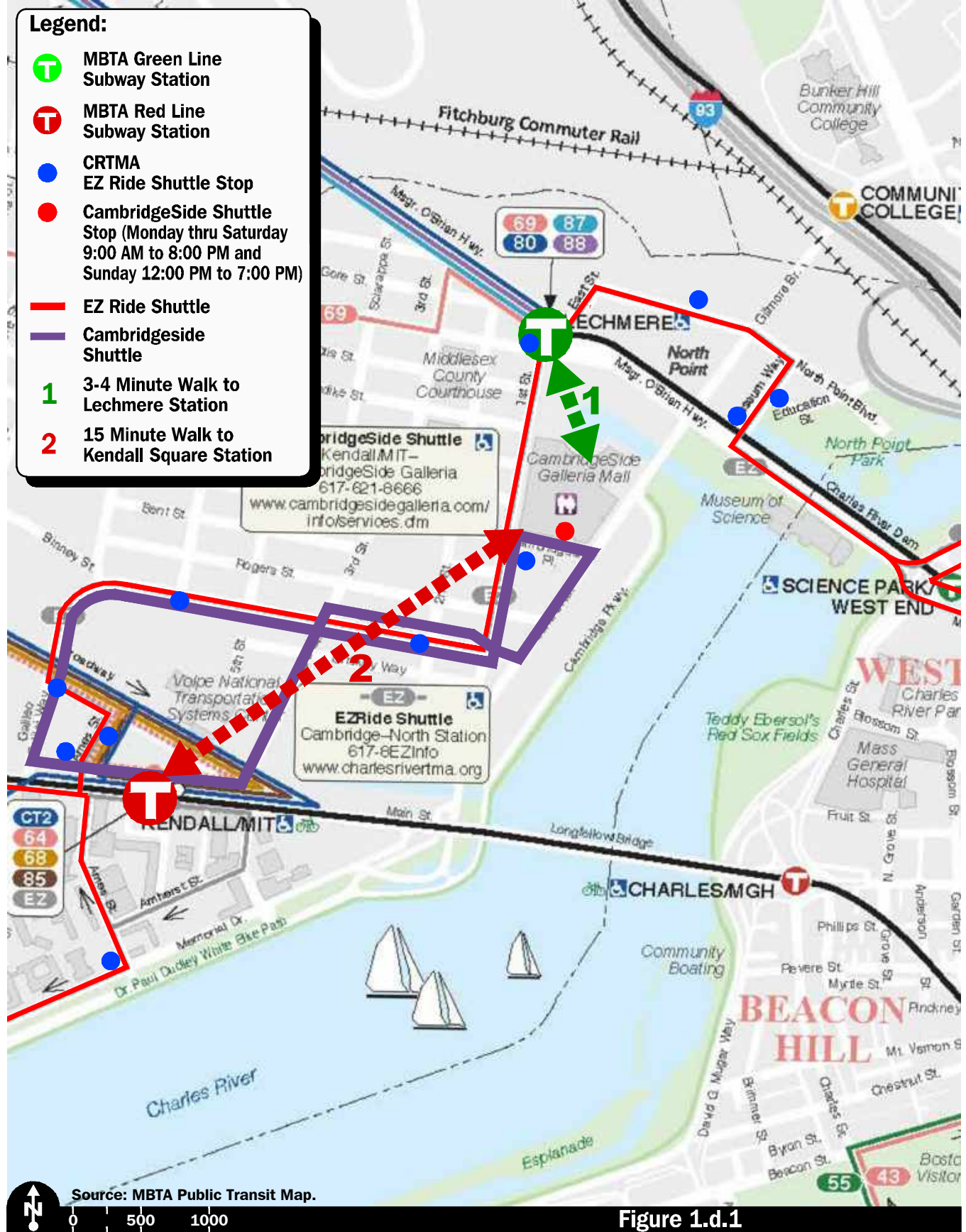
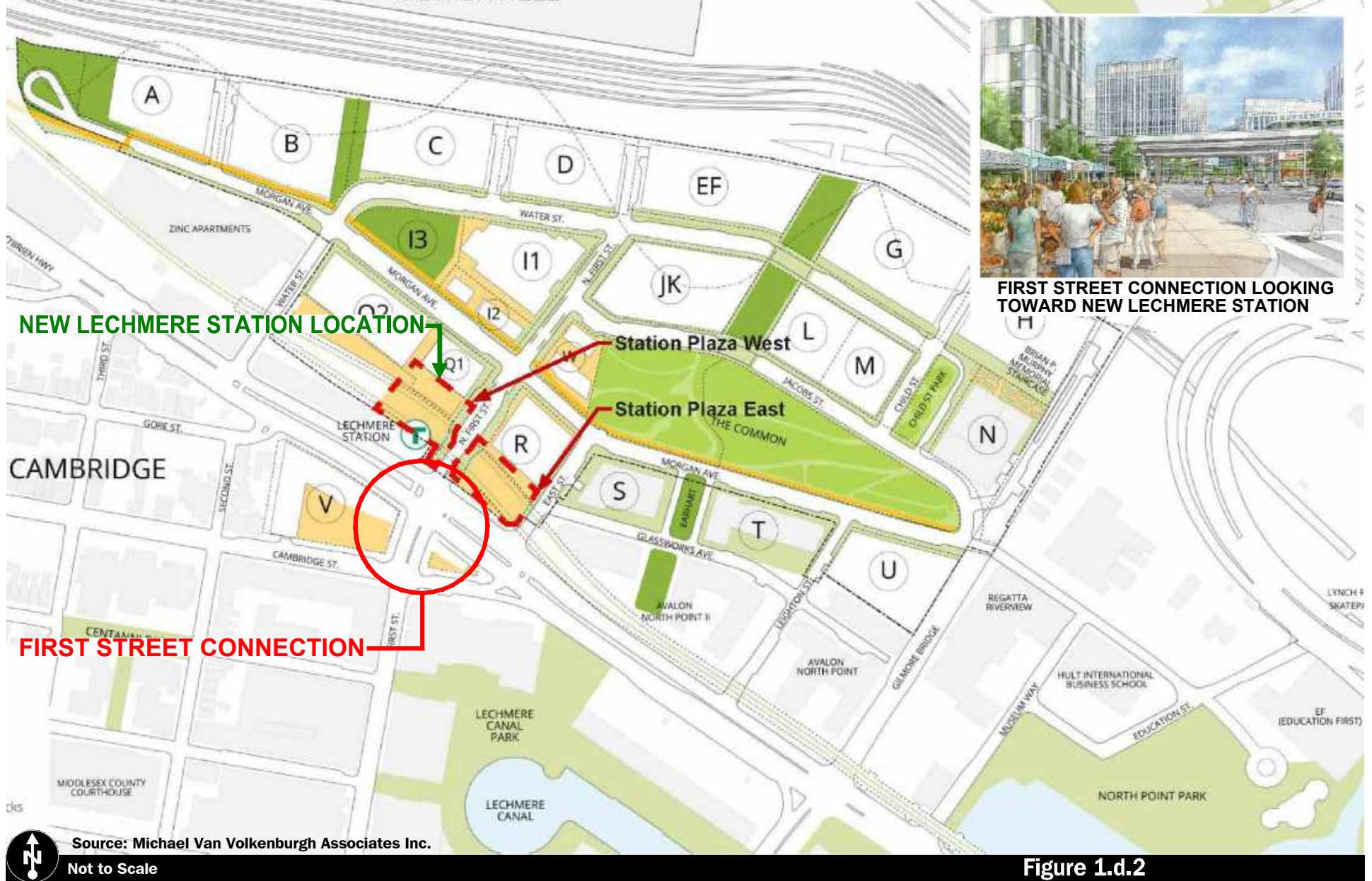


Figure 1.d.1

Transit Map





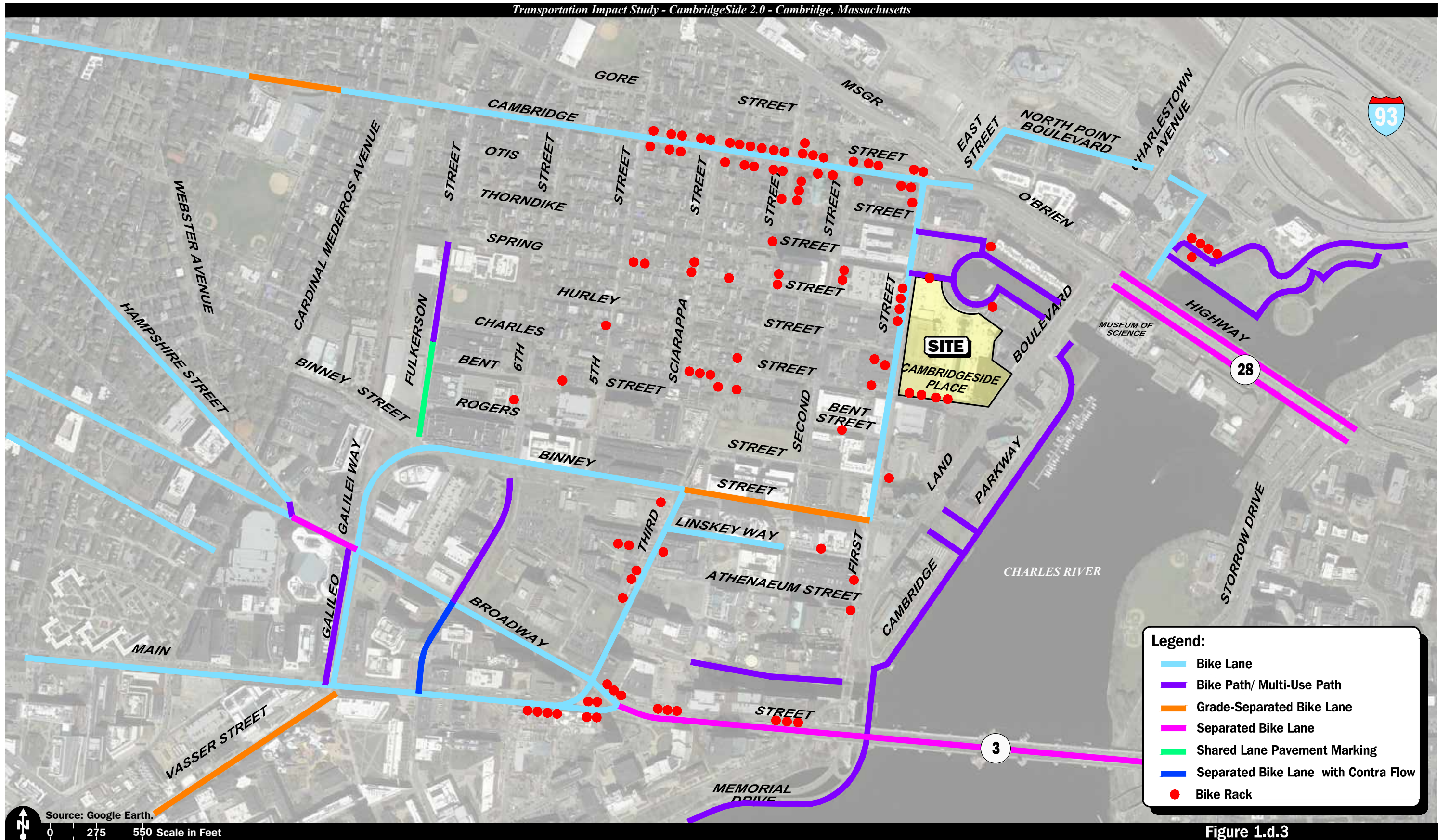
FIRST STREET CONNECTION LOOKING TOWARD NEW LECHMERE STATION

Source: Michael Van Volkenburgh Associates Inc.
Not to Scale

Figure 1.d.2

Proposed First Street Connection and Proposed Lechmere Station Location





Legend:

- Bike Lane
- Bike Path/ Multi-Use Path
- Grade-Separated Bike Lane
- Separated Bike Lane
- Shared Lane Pavement Marking
- Separated Bike Lane with Contra Flow
- Bike Rack

Source: Google Earth.
 0 275 550 Scale in Feet

Figure 1.d.3
 Bicycle Parking and
 Route Access Map

R:\7810\Cambridgeside 2.0\7810bike.dwg, 4/21/2020 1:43:46 PM

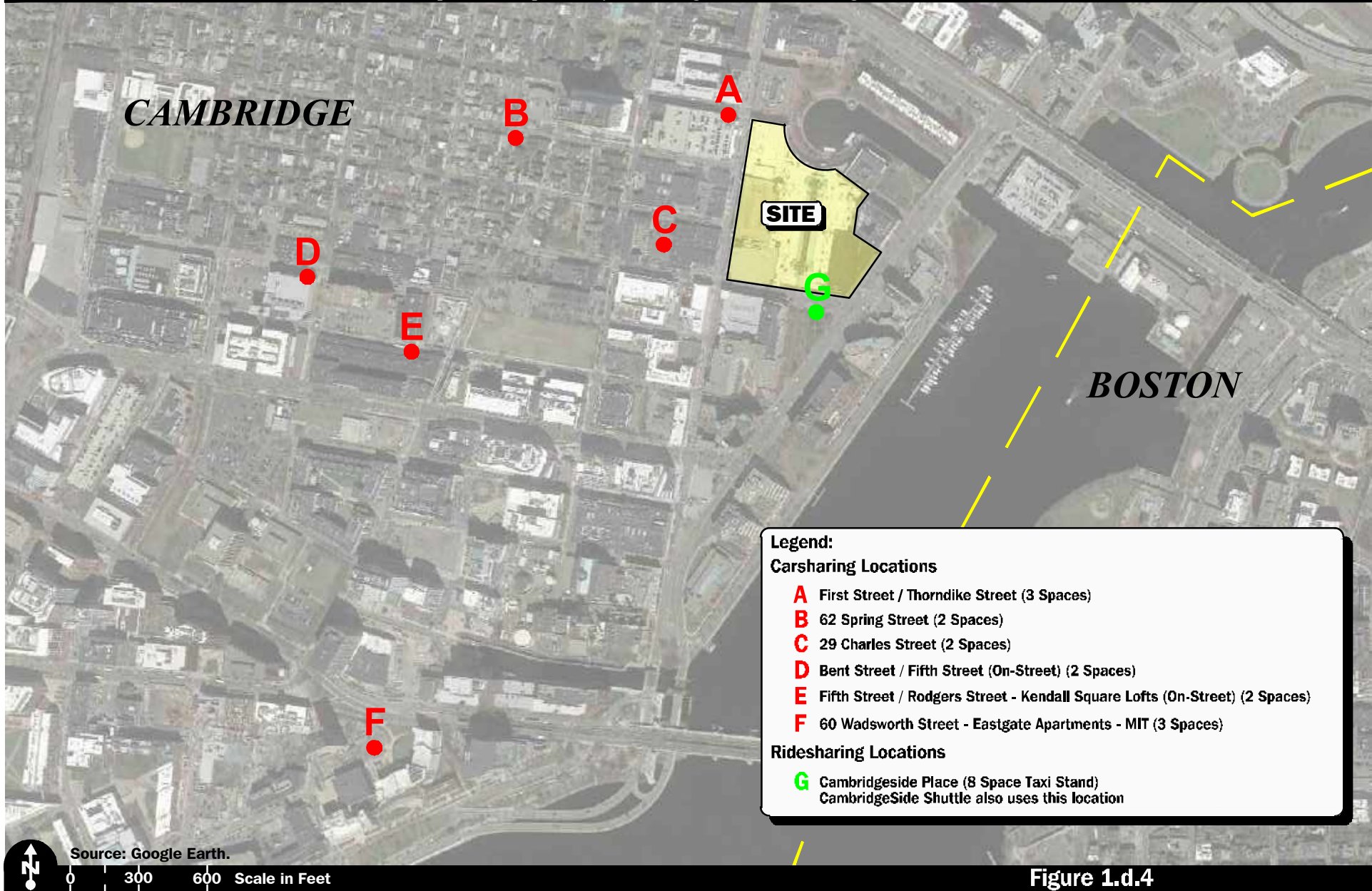


Figure 1.d.4
Carsharing and Ridesharing Services Map



Figure 1.d.5
Bikesharing Stations Map



R:\7810\Cambridgeside 2.0\7810ridessharing2.dwg, 5/22/2020 7:53:35 AM

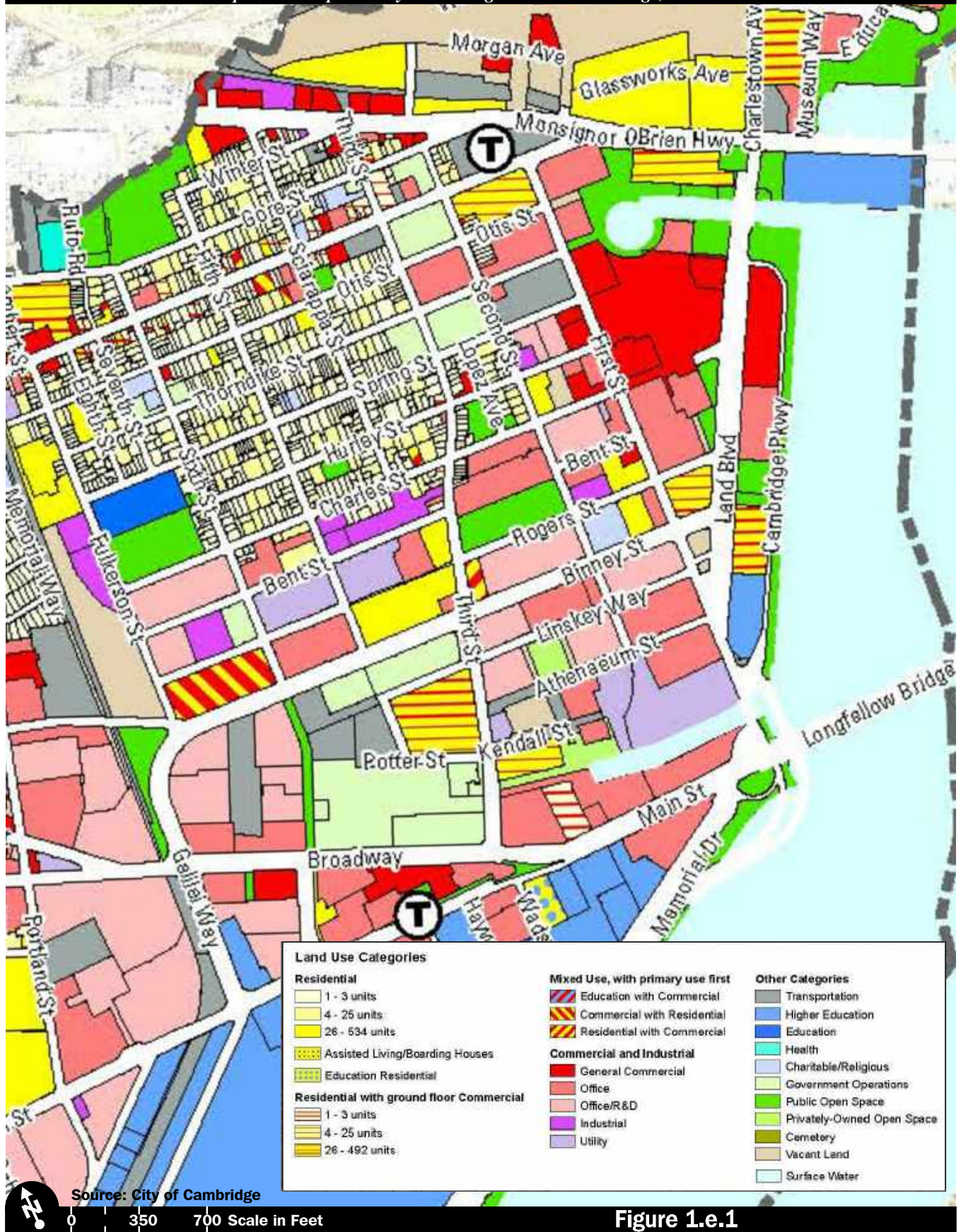


Figure 1.e.1

Land Use Map



Transportation Impact Study Supporting Graphics Volume II of II Section 2.0 through Section 14.0

CambridgeSide 2.0 Redevelopment
Cambridge, Massachusetts

Prepared for:

New England Development, On Behalf Of:

Cambridgeside Galleria Associates Trust,
Cambridgeside Partners LLC, And
NW Cambridge Property Owner LLC

Cambridge, Massachusetts

July 2020

Prepared by:



35 New England Business Center Drive
Suite 140
Andover, MA 01810

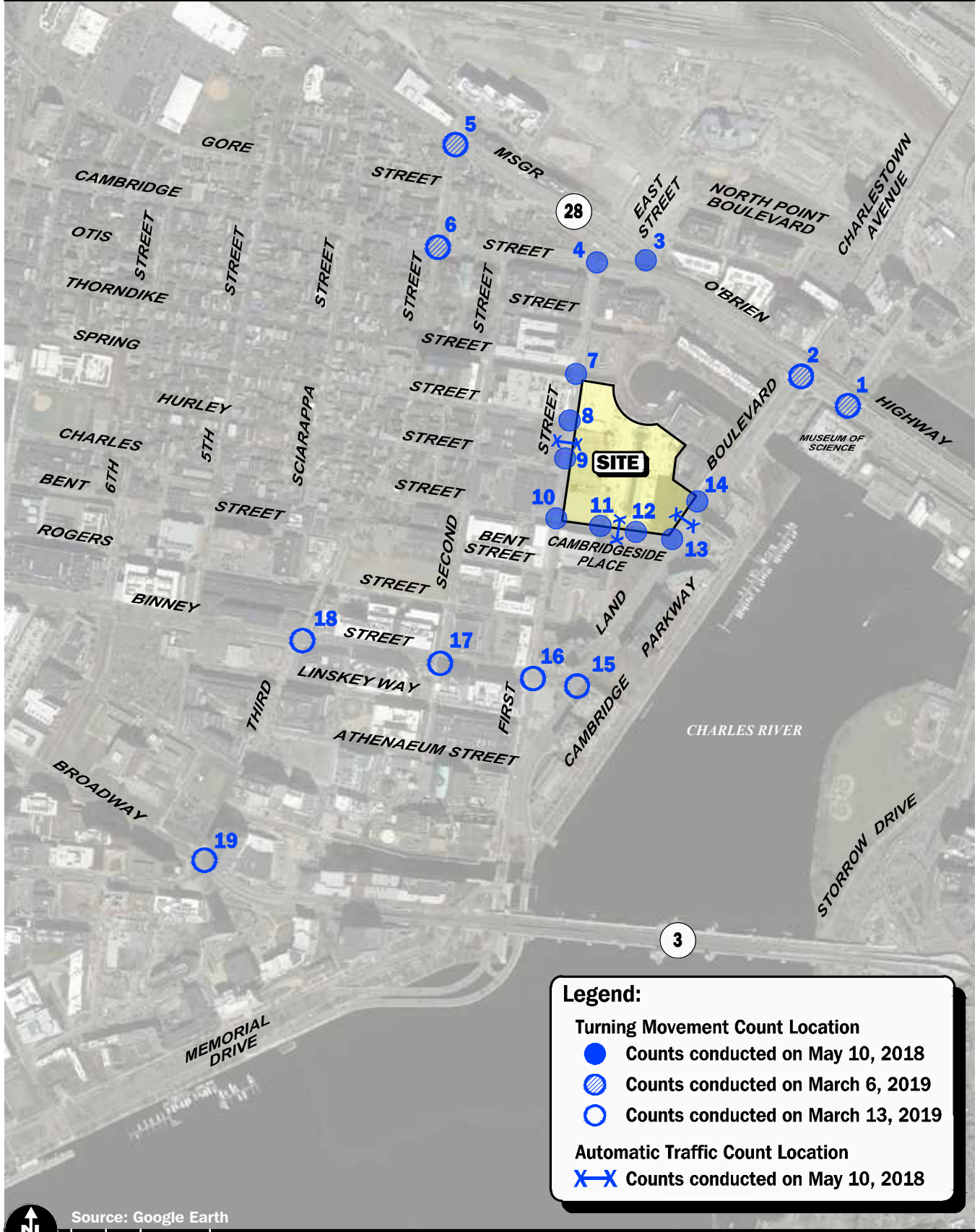


Figure 2.a.1

Count Location Map



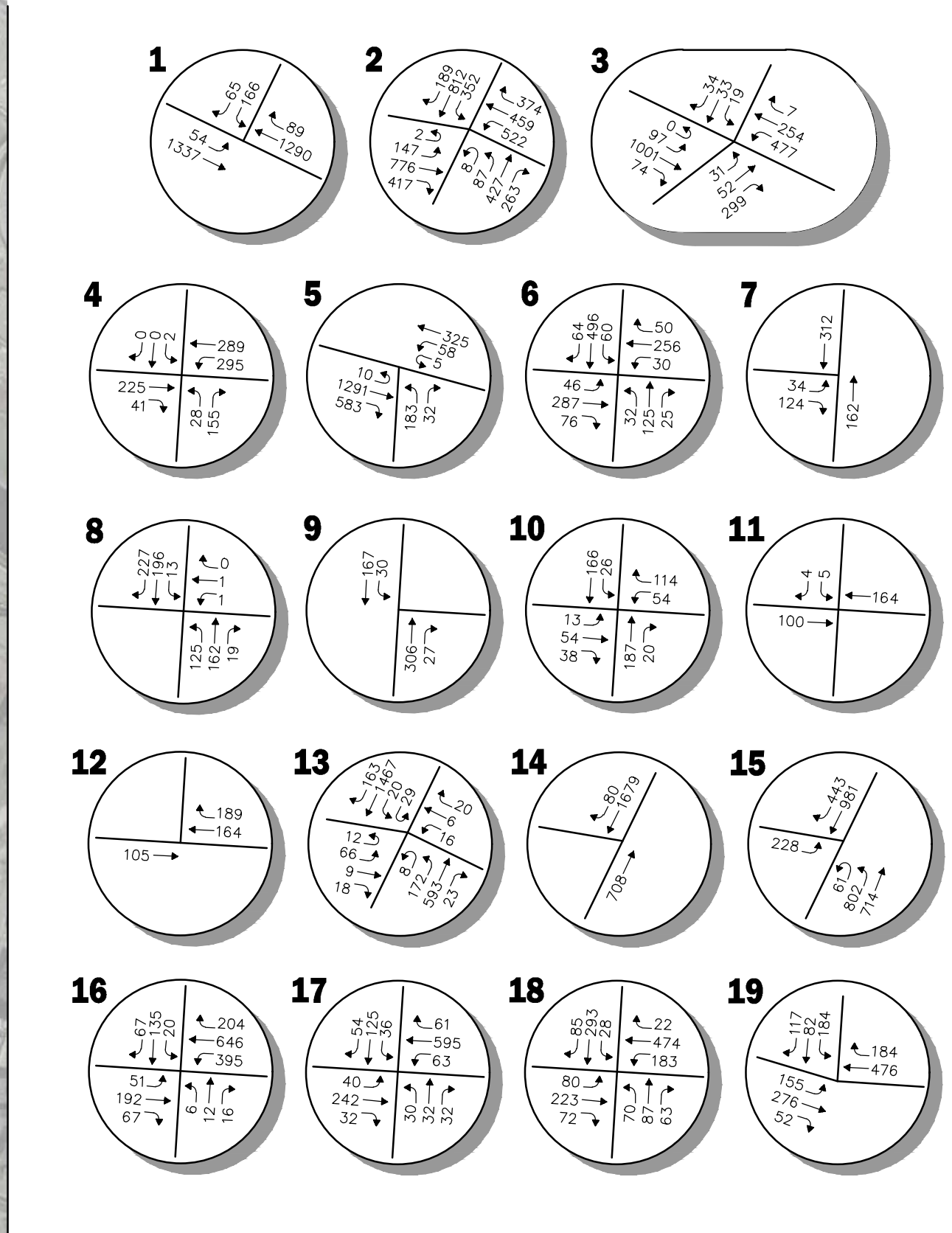
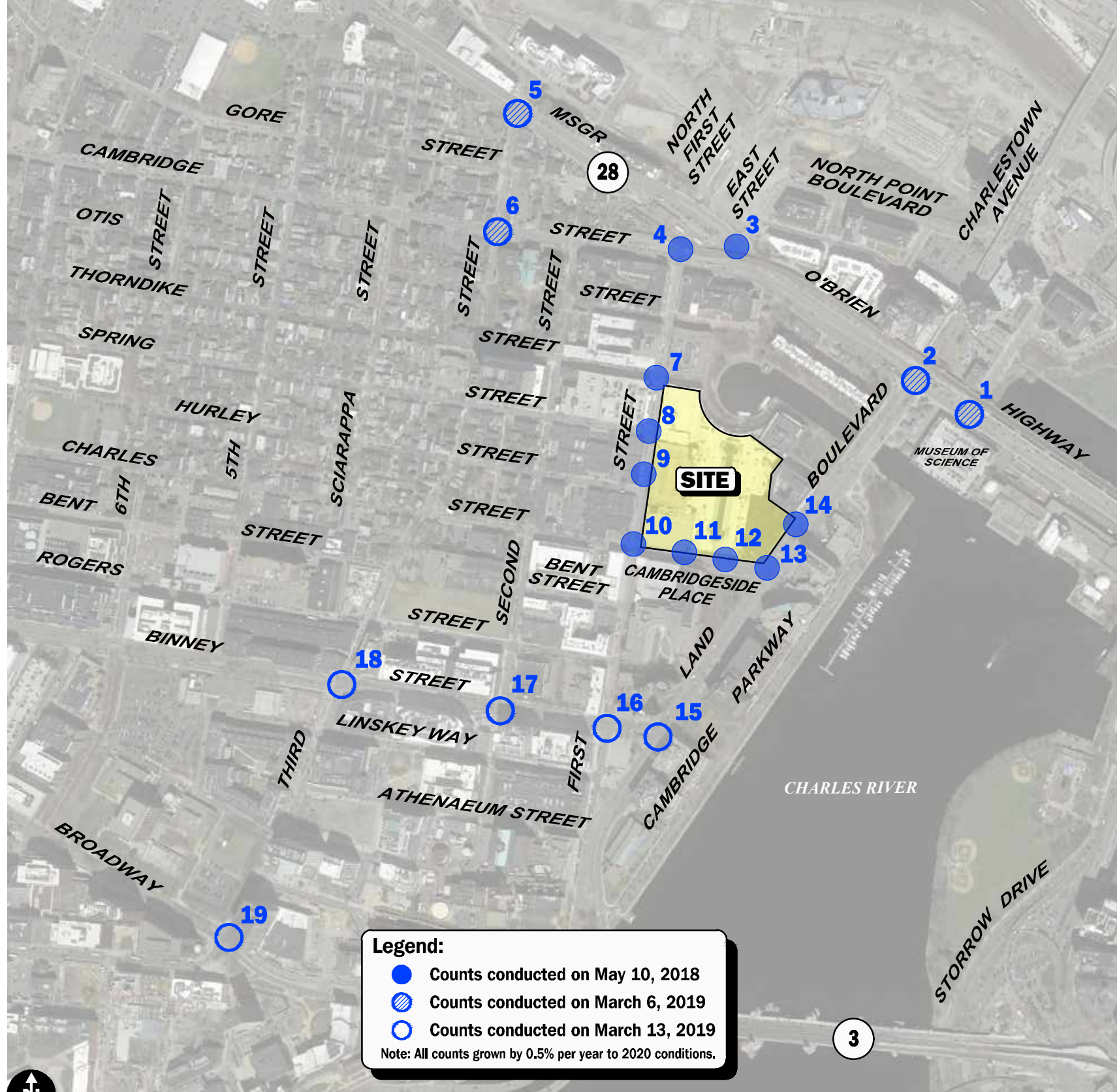


Figure 2.c.1
 2020 Existing
 Weekday Morning
 Peak Hour Traffic Volumes

R:\7810\Cambridgeside 2.0\7810\NT1.dwg, 7/9/2020 12:21:08 PM

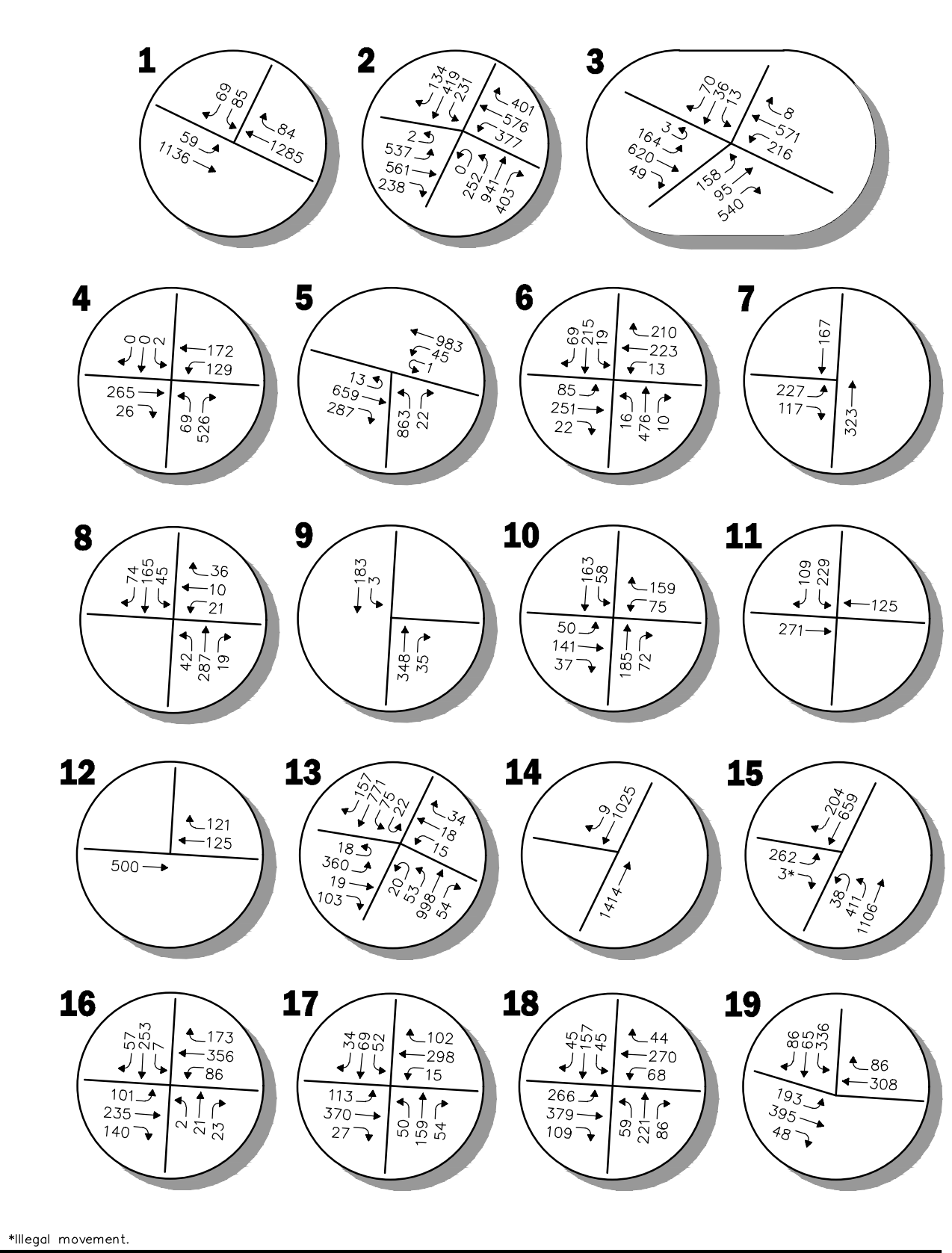
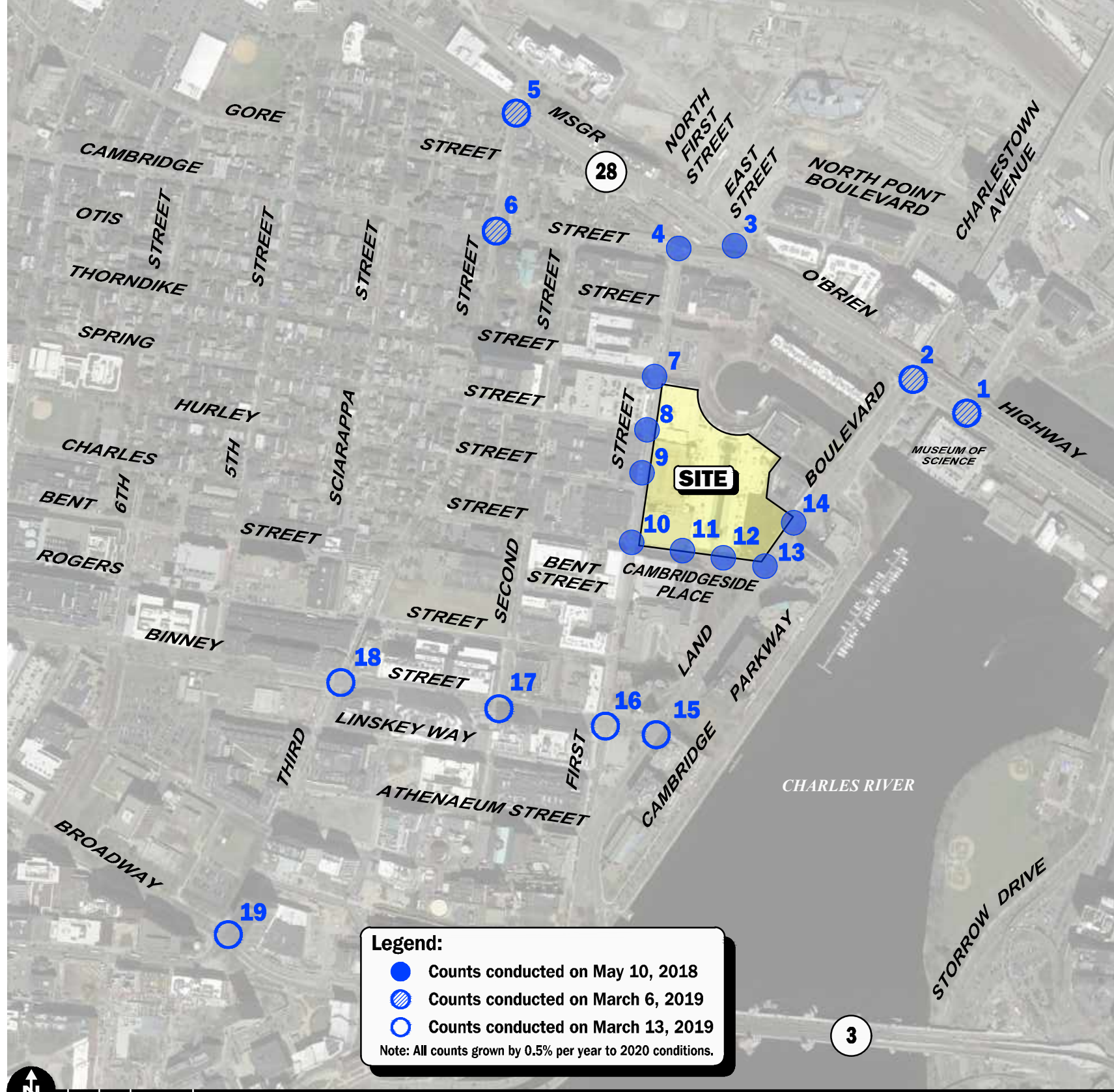


Figure 2.c.2
 2020 Existing
 Weekday Evening
 Peak Hour Traffic Volumes

R:\17810\Cambridgeside 2.0\17810\NT1.dwg, 7/19/2020 12:22:13 PM

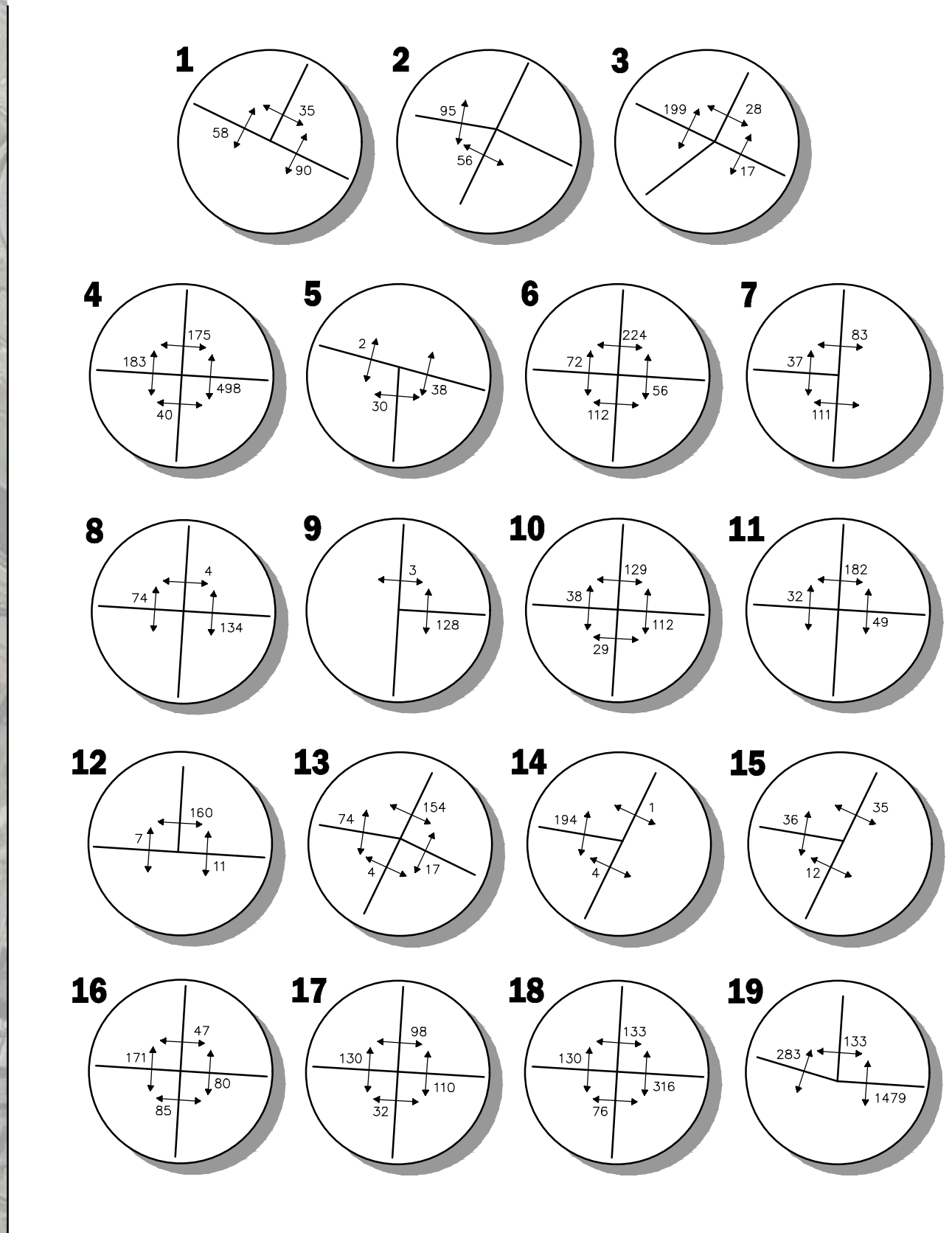
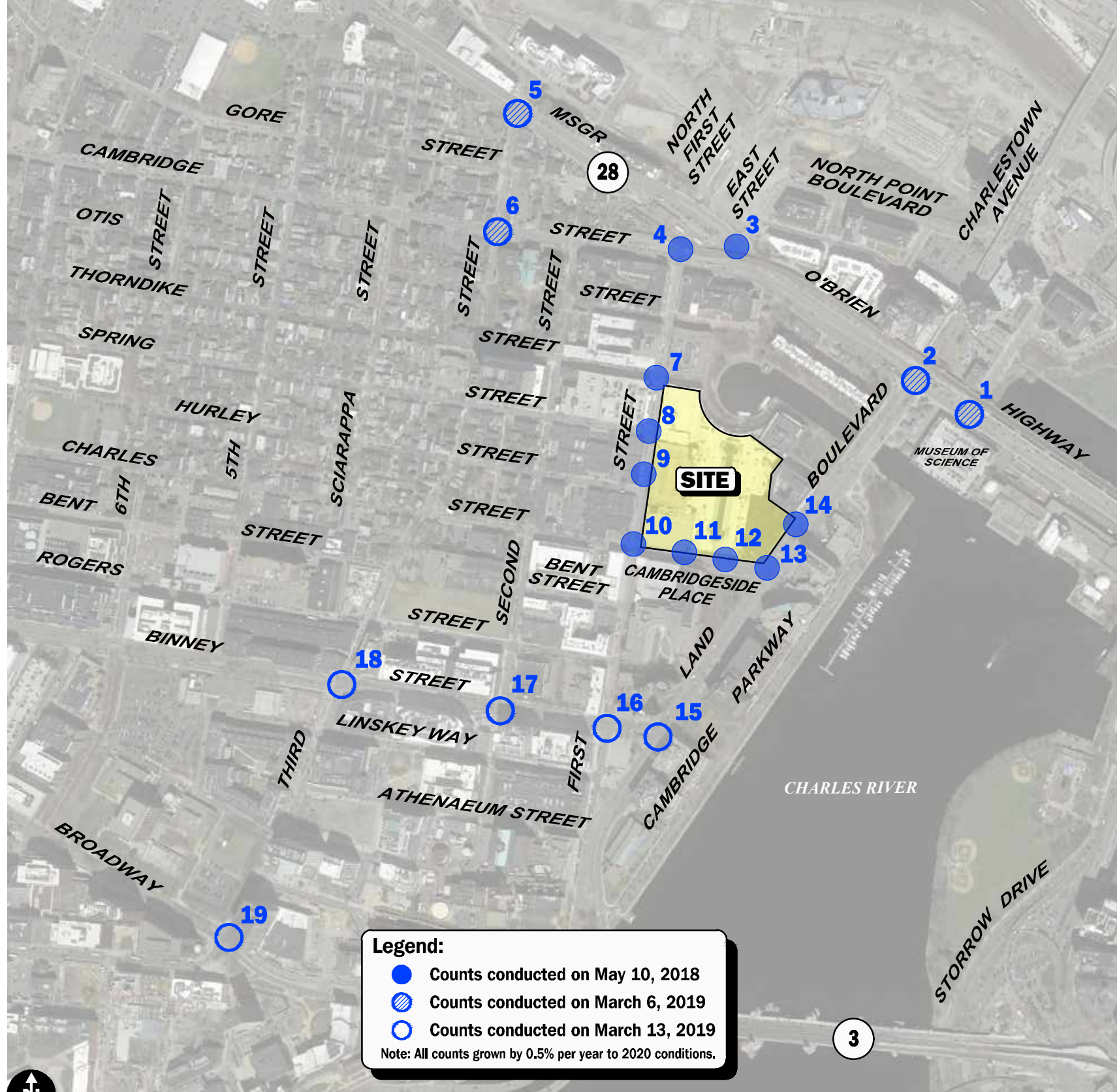
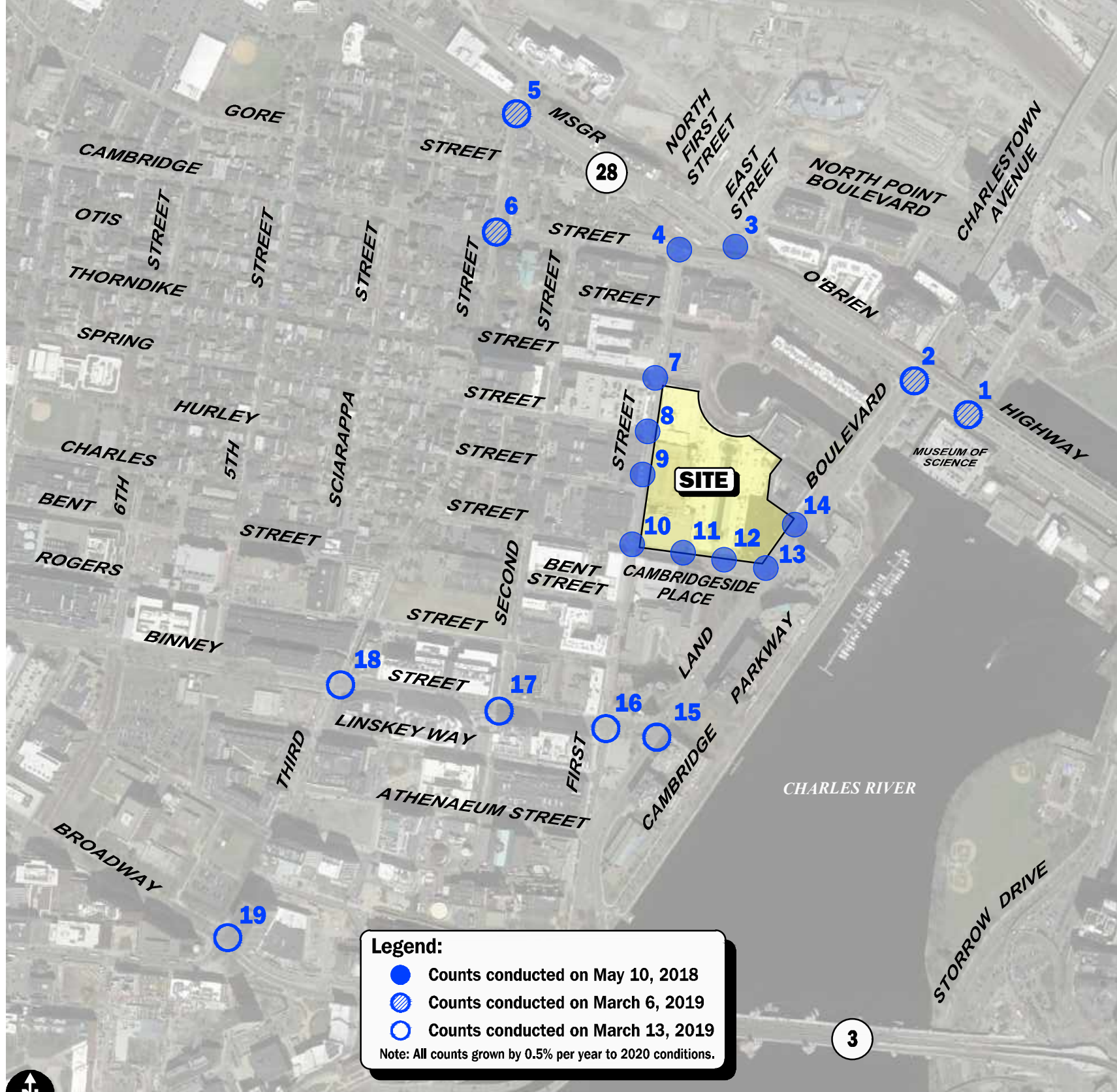


Figure 2.c.3
 2020 Existing
 Weekday Morning
 Peak Hour Pedestrian Volumes



Legend:

- Counts conducted on May 10, 2018
- ◐ Counts conducted on March 6, 2019
- Counts conducted on March 13, 2019

Note: All counts grown by 0.5% per year to 2020 conditions.

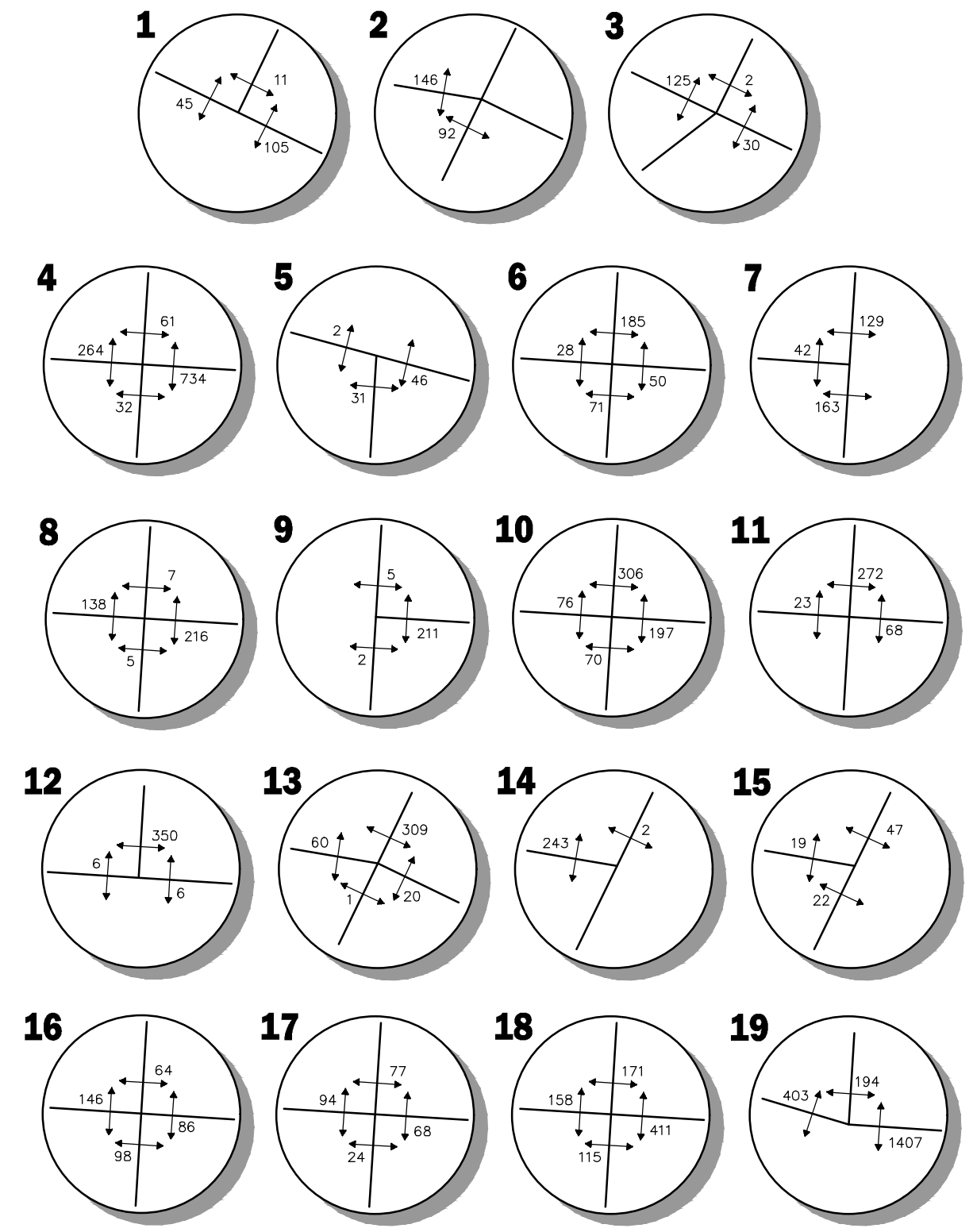
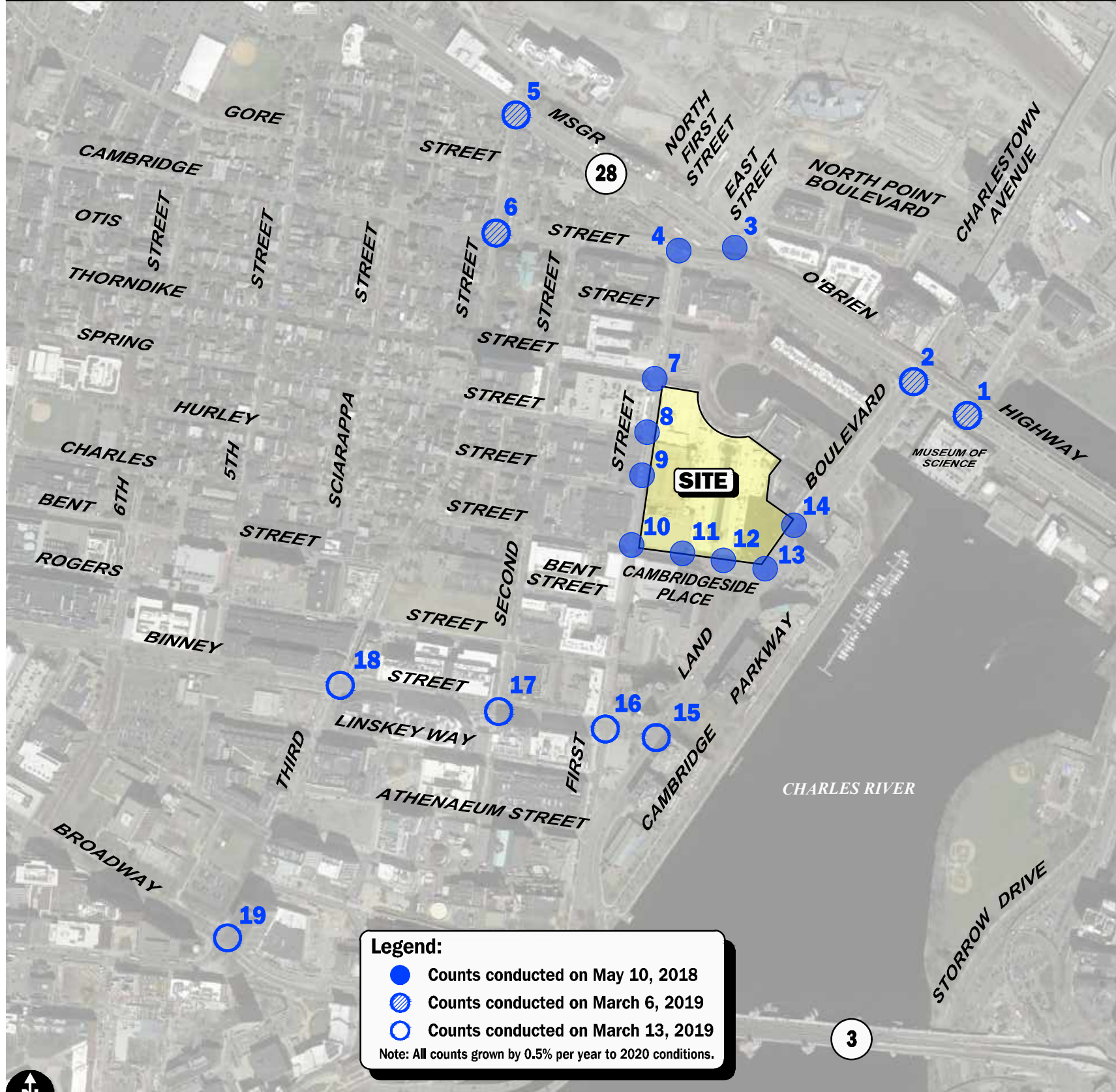


Figure 2.c.4
 2020 Existing
 Weekday Evening
 Peak Hour Pedestrian Volumes

R:\7810\Cambridgeside 2.0\7810NT1.dwg, 7/9/2020 12:24:45 PM



Legend:

- Counts conducted on May 10, 2018
- ◐ Counts conducted on March 6, 2019
- Counts conducted on March 13, 2019

Note: All counts grown by 0.5% per year to 2020 conditions.

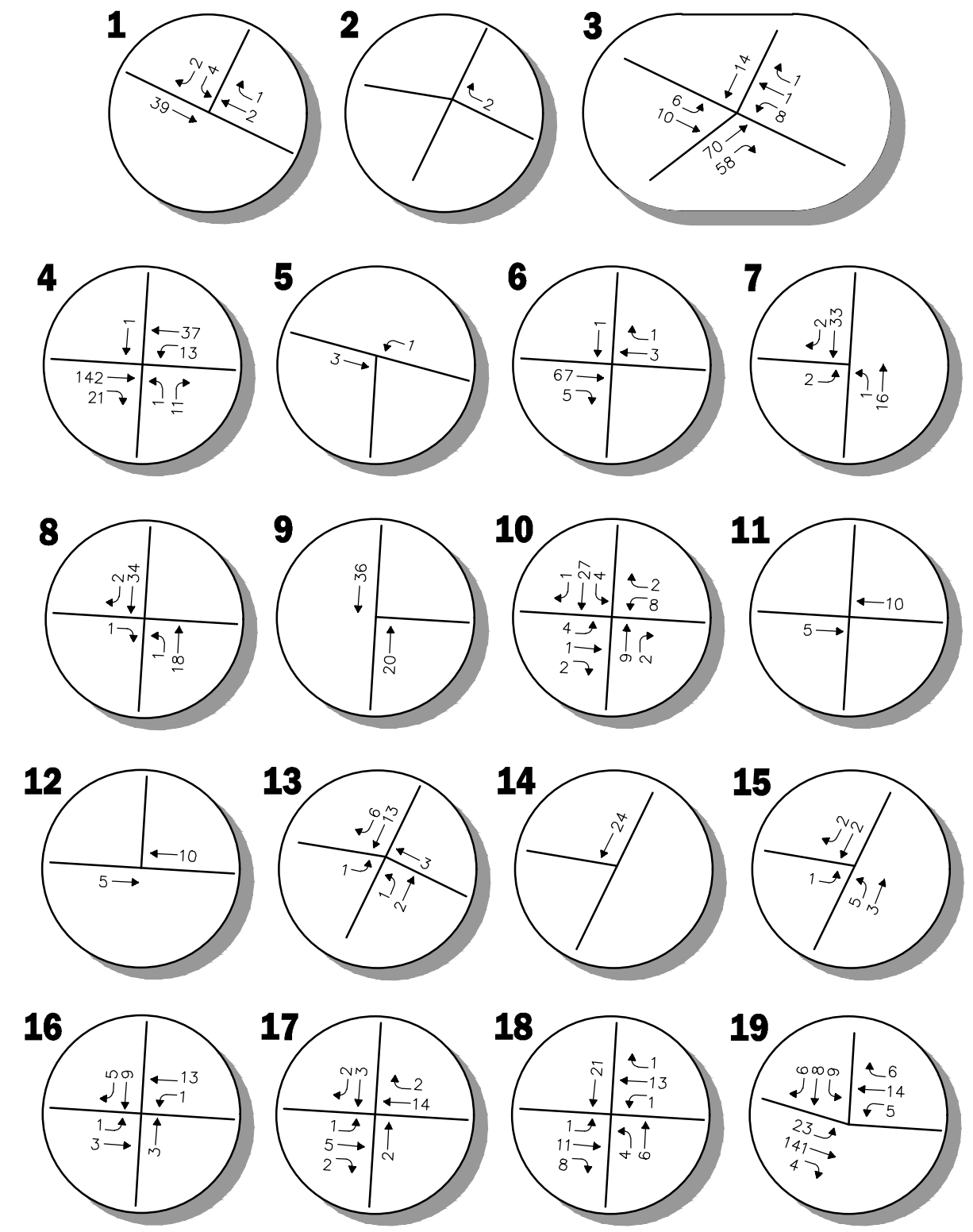


Figure 2.c.5
 2020 Existing
 Weekday Morning
 Peak Hour Bicycle Volumes

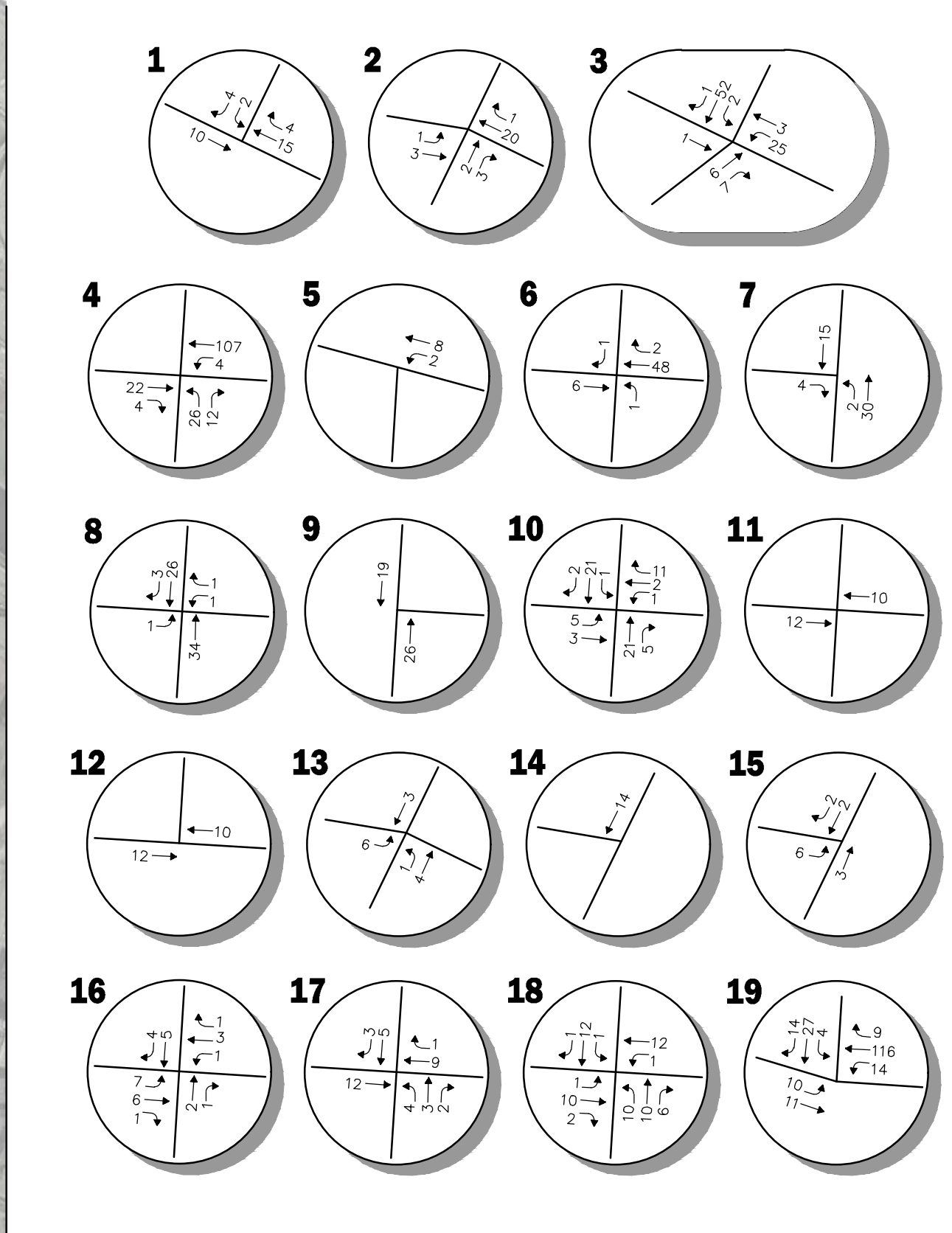
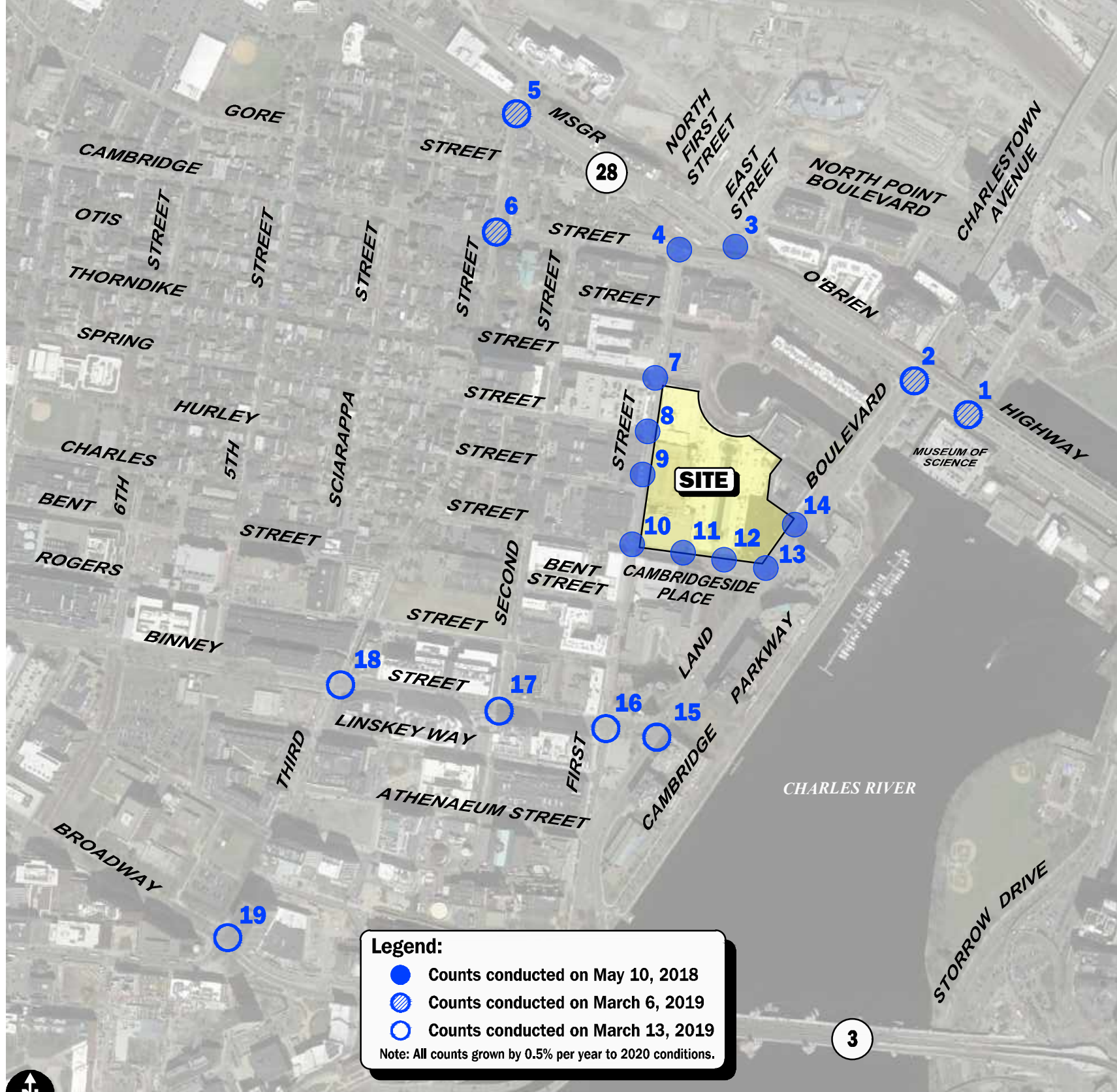


Figure 2.c.6
 2020 Existing
 Weekday Evening
 Peak Hour Bicycle Volumes

R:\7810\Cambridgeside 2.0\7810NT1.dwg, 7/9/2020 12:26:54 PM

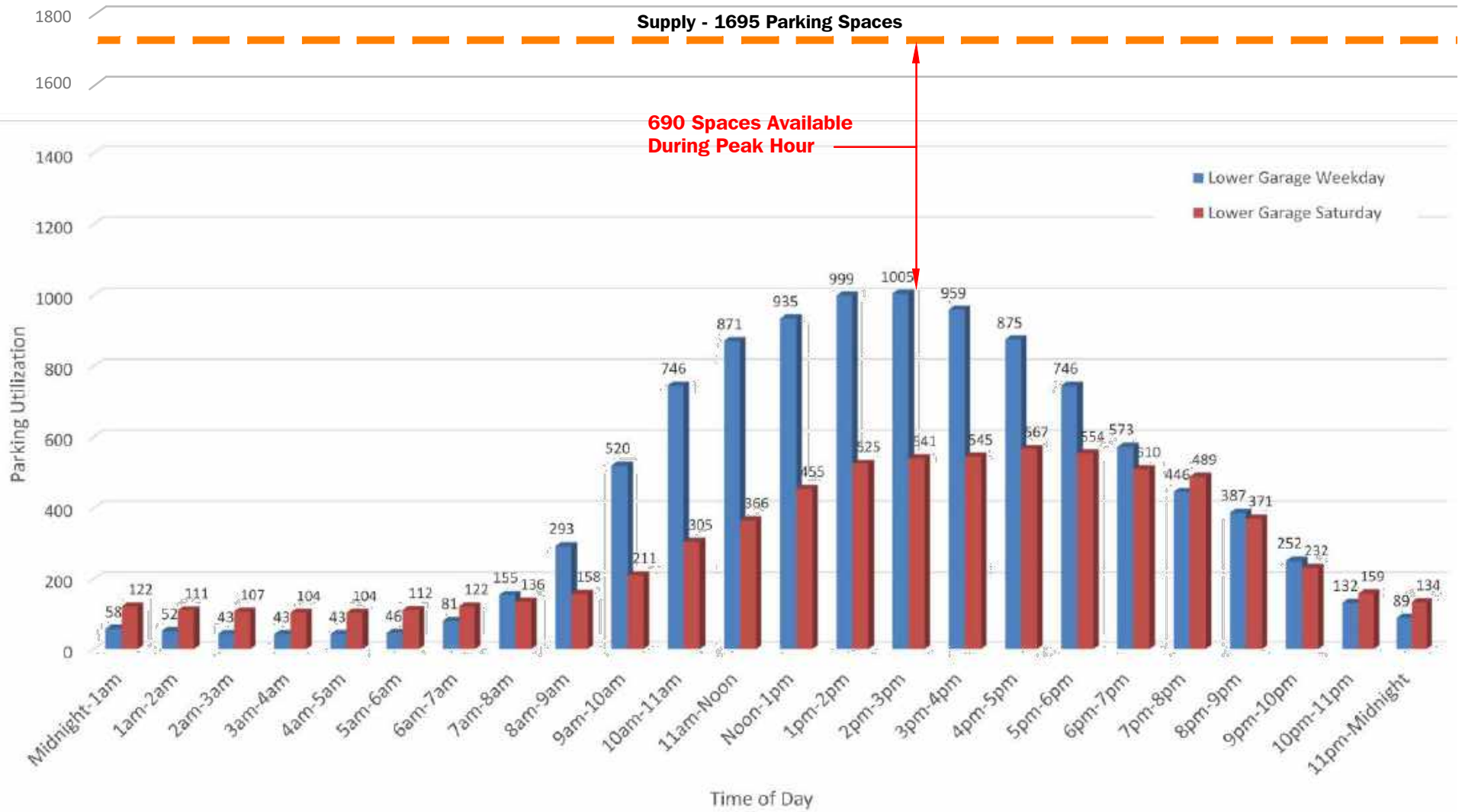


Figure 2.f.1

Parking Utilization Chart
Lower Garage



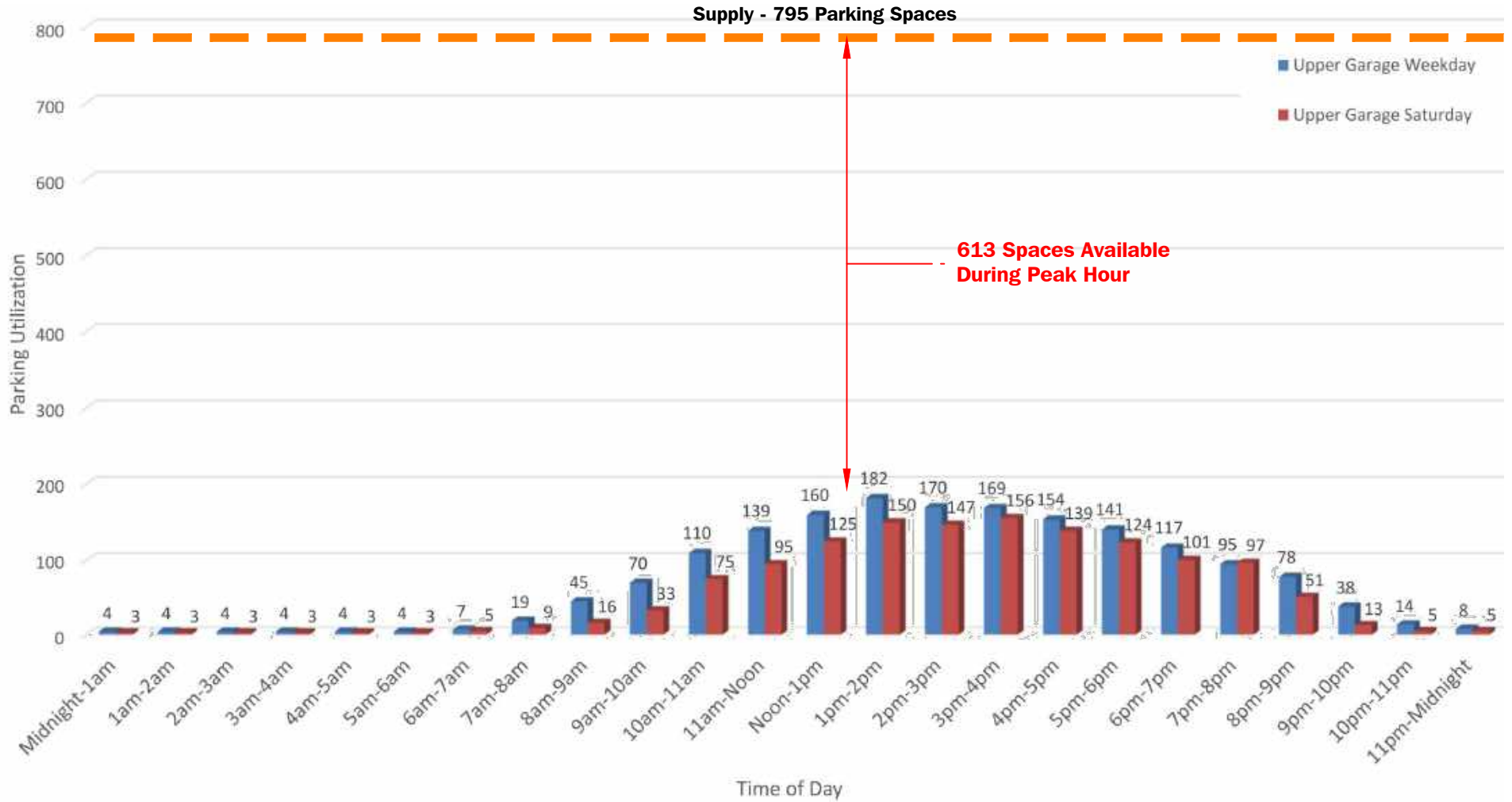


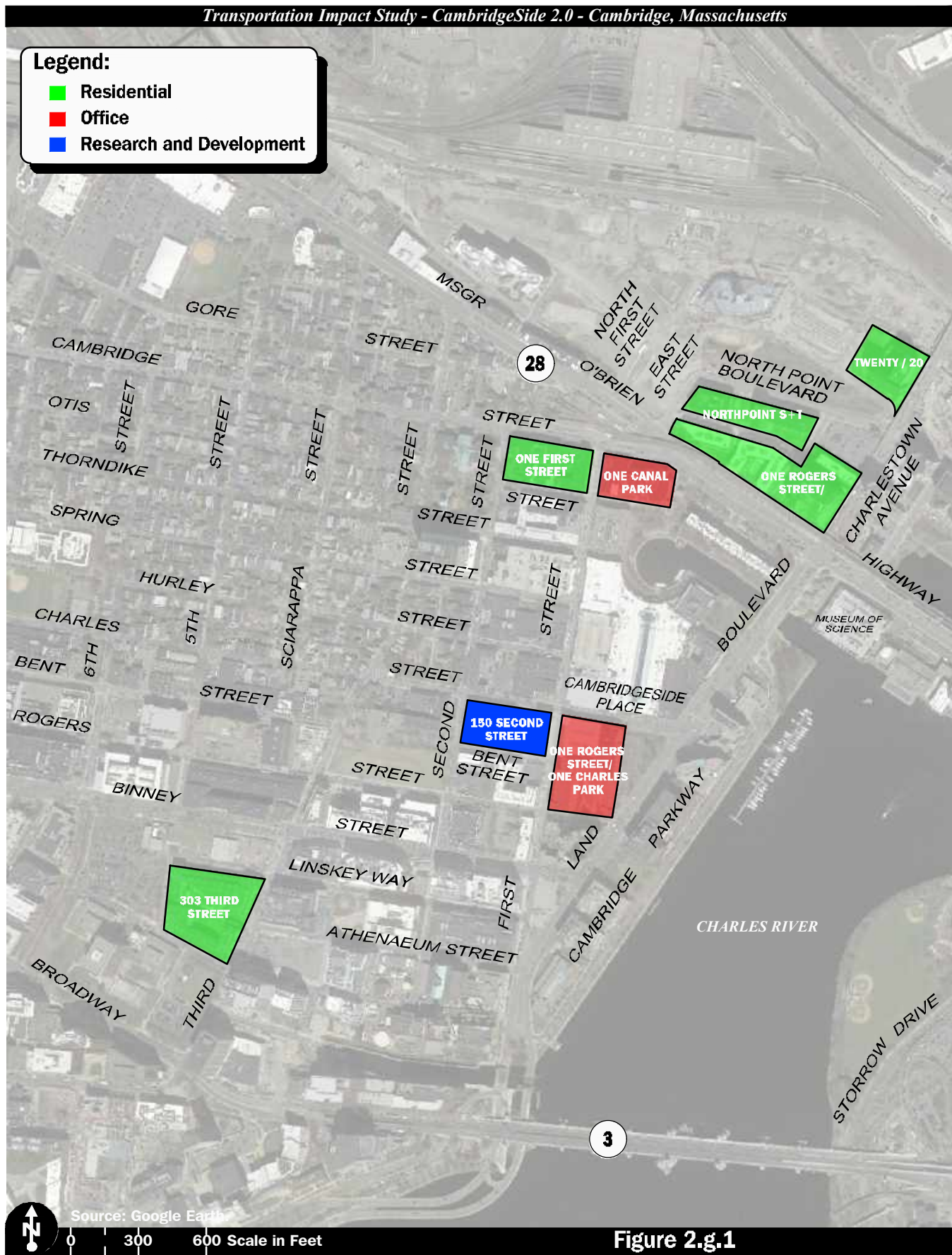
Figure 2.f.2

Parking Utilization Chart
Upper Garage



Legend:

- Residential
- Office
- Research and Development



Source: Google Earth
 0 300 600 Scale in Feet

Figure 2.g.1

**East Cambridge Area
 Comparable Office Sites**



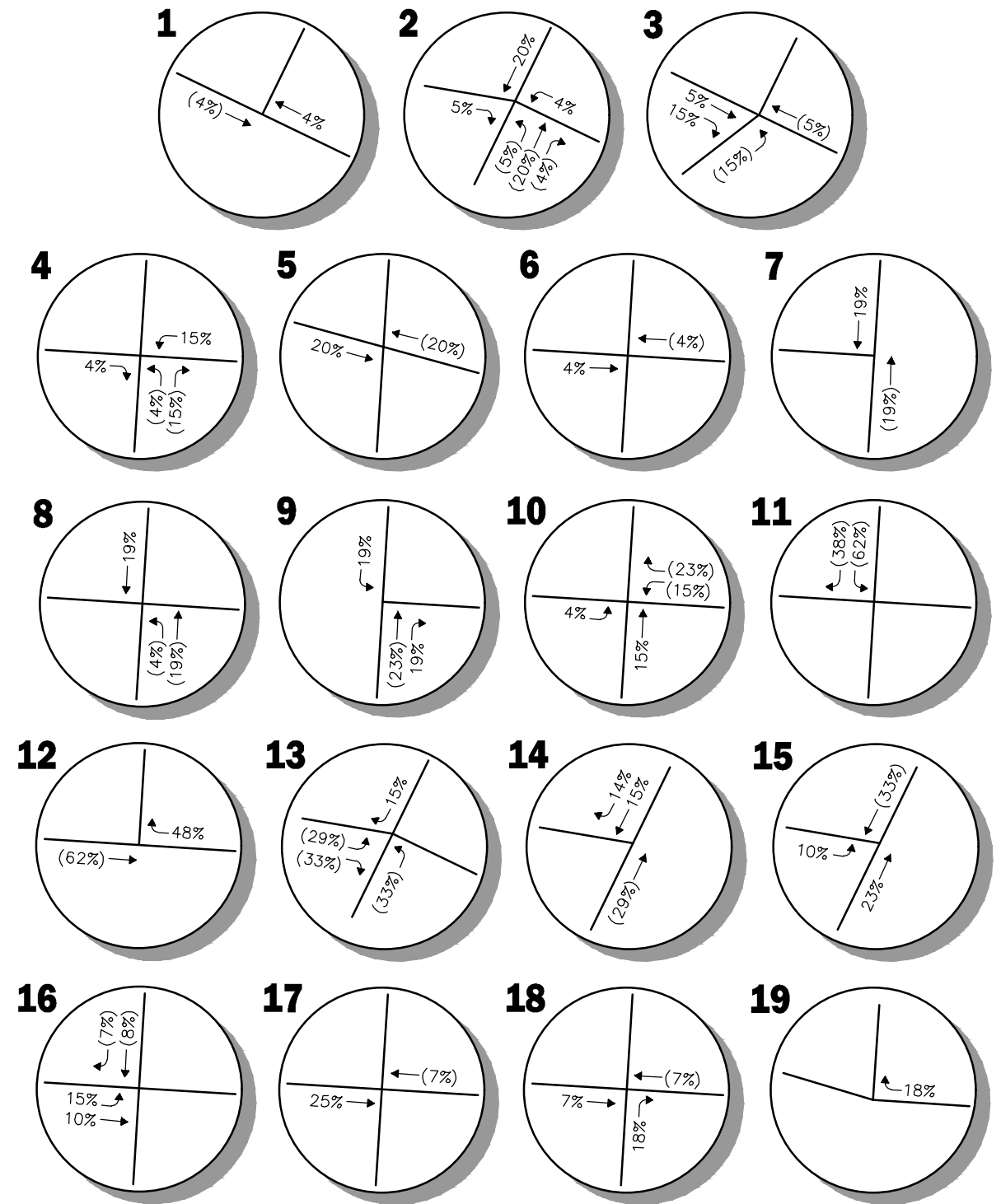
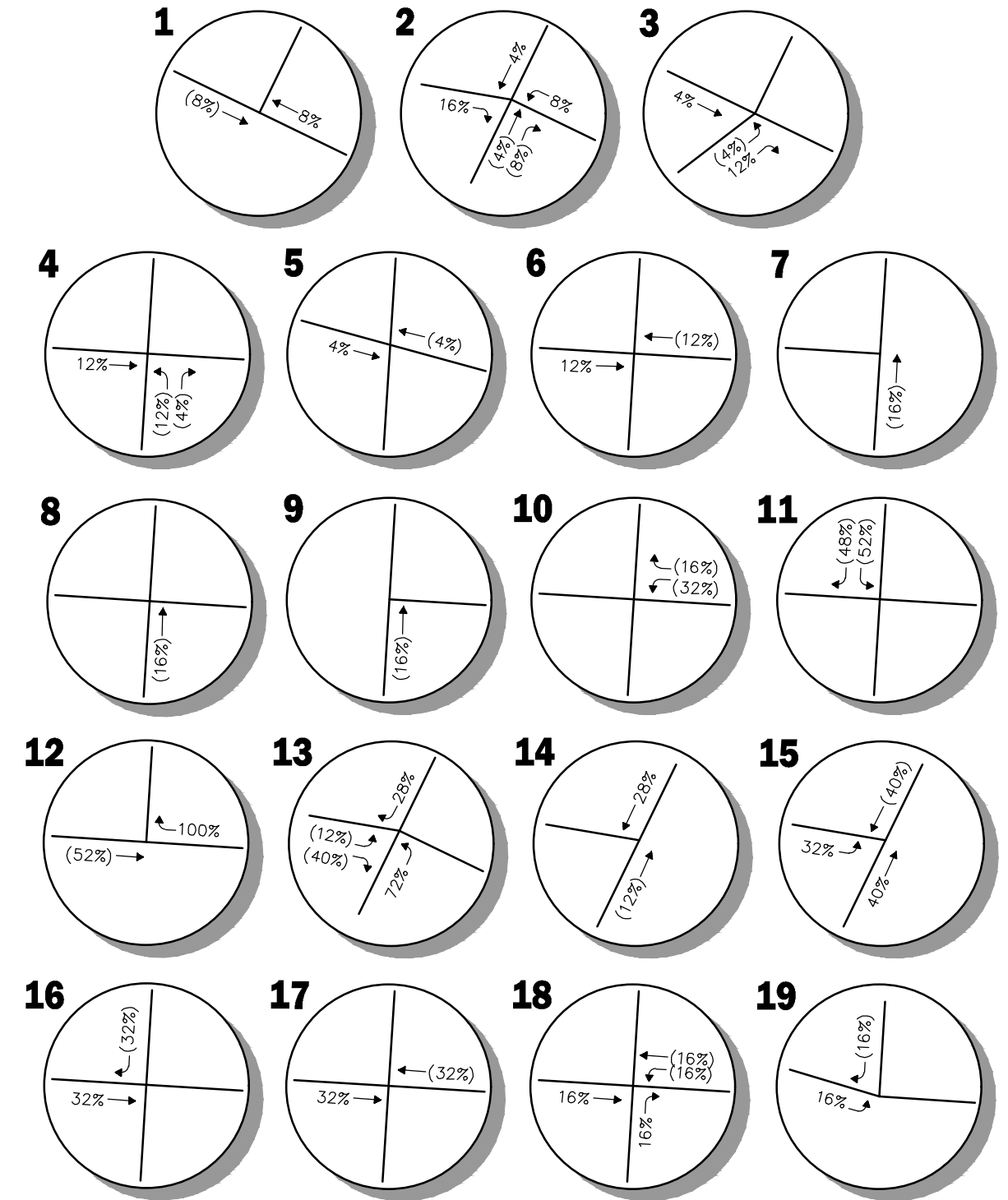
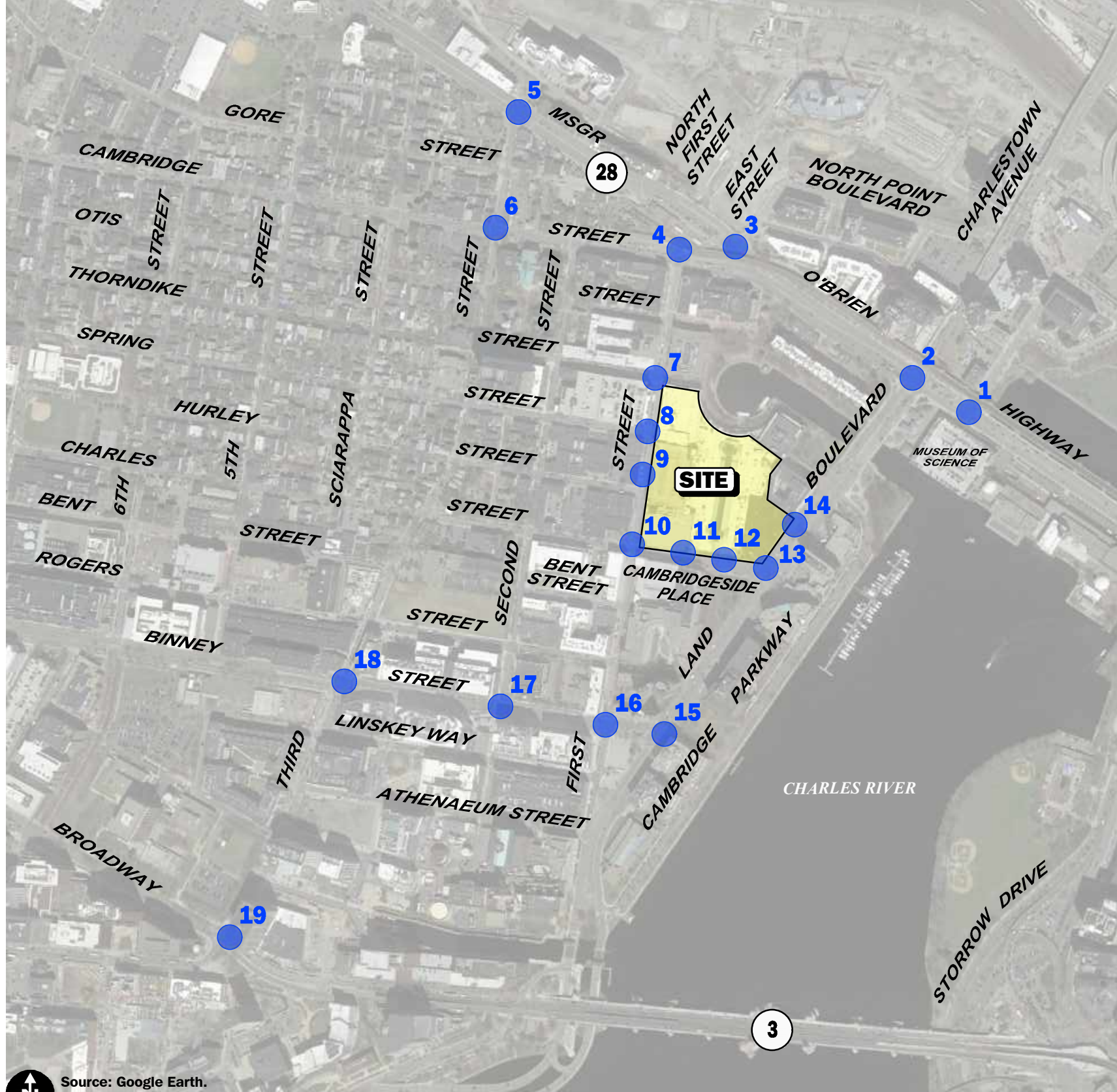


Figure 3.b.1

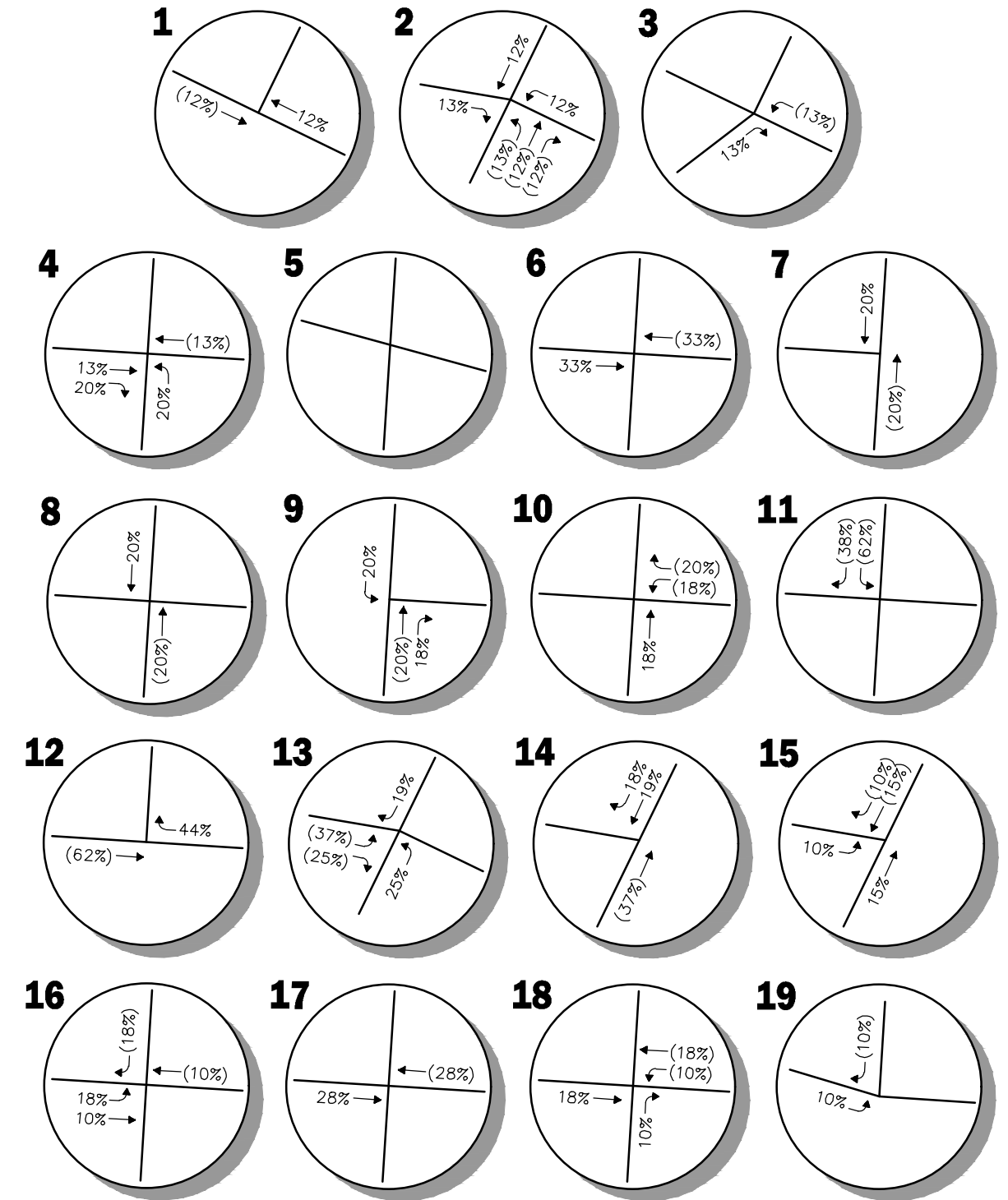
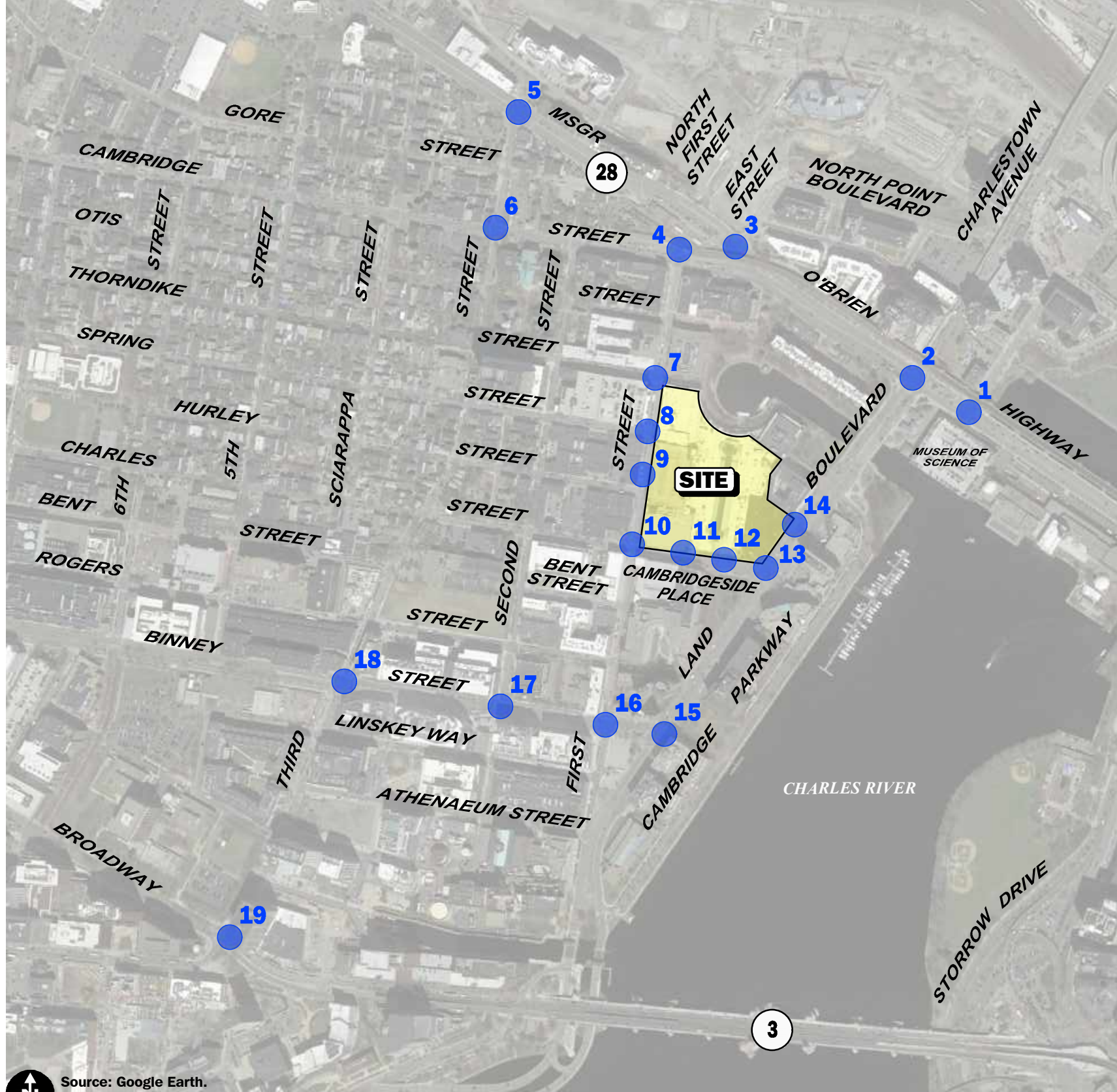
Office / R&D
Trip Distribution



Legend:
 XX Entering Trips
 (XX) Exiting Trips

Figure 3.b.2
 Residential
 Trip Distribution

R:\7810\Cambridgeside 2.0\7810NT2.dwg, 7/9/2020 12:29:20 PM



Legend:
 XX Entering Trips
 (XX) Exiting Trips

Figure 3.b.3

Retail Trip Distribution

R:\7810\Cambridgeside 2.0\7810NT2.dwg, 7/9/2020 12:30:22 PM

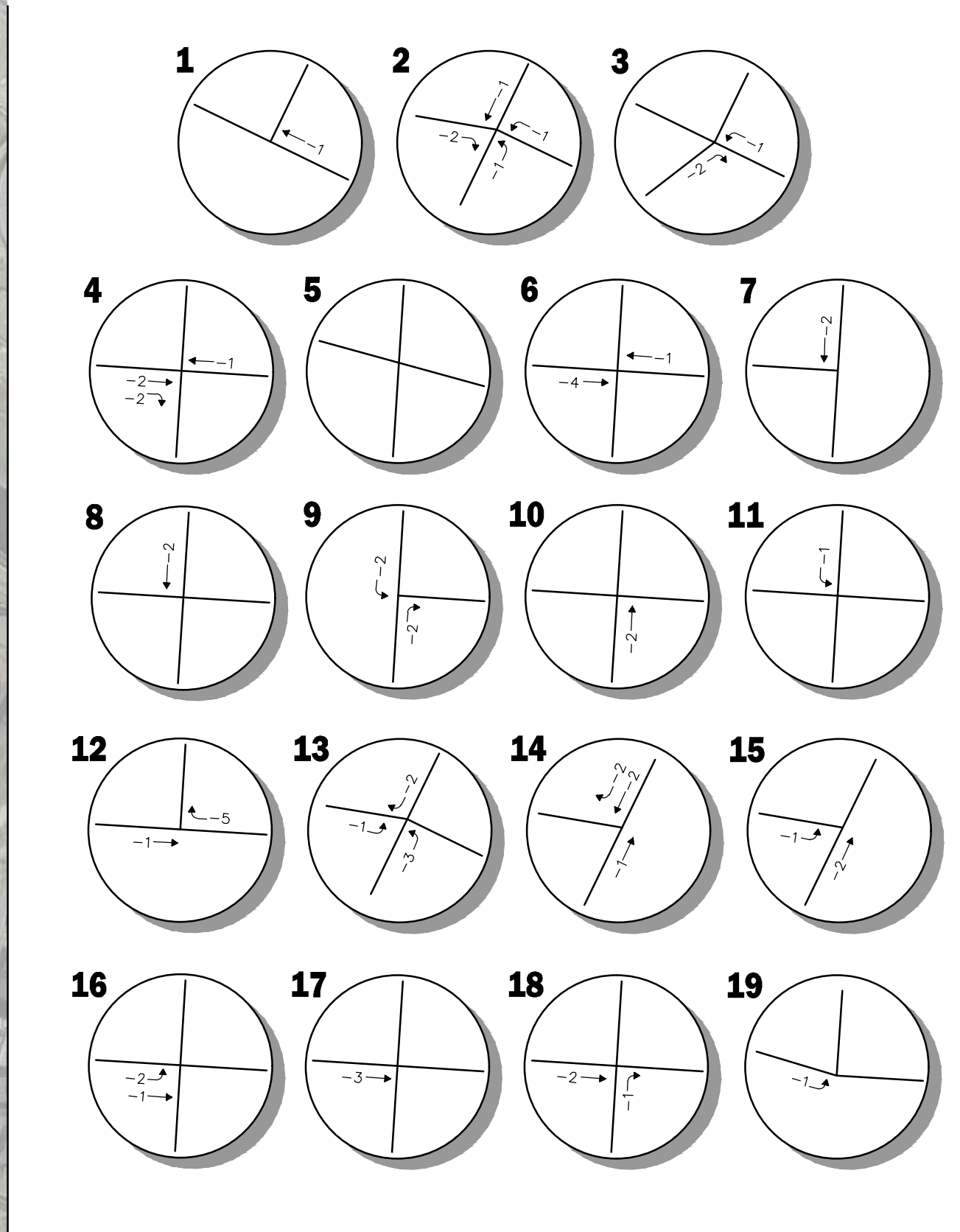
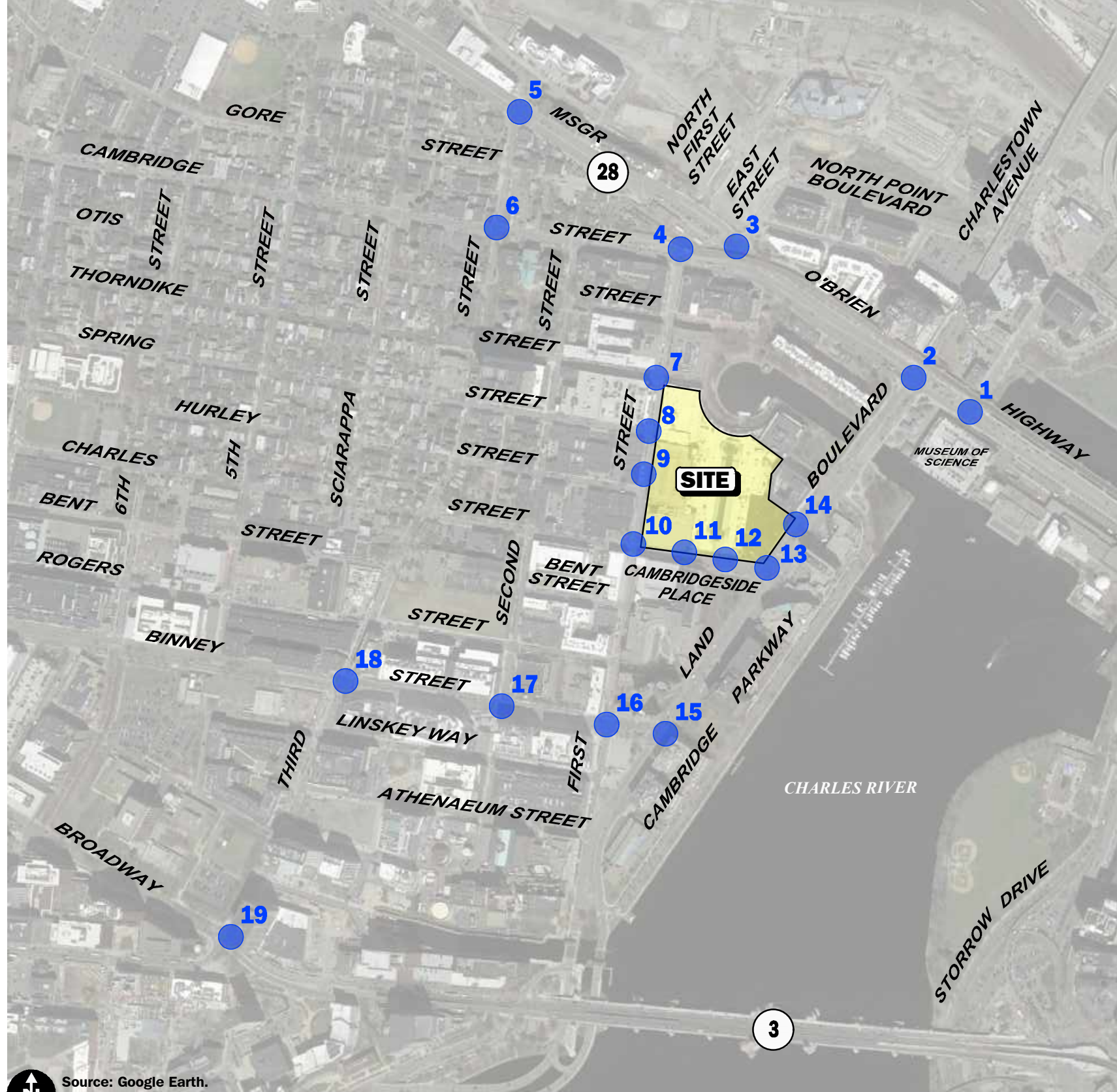


Figure 3.c.1
3rd Floor Retail Trips Removed
Weekday Morning
Peak Hour Traffic Volumes

Source: Google Earth.
 0 275 550 Scale in Feet



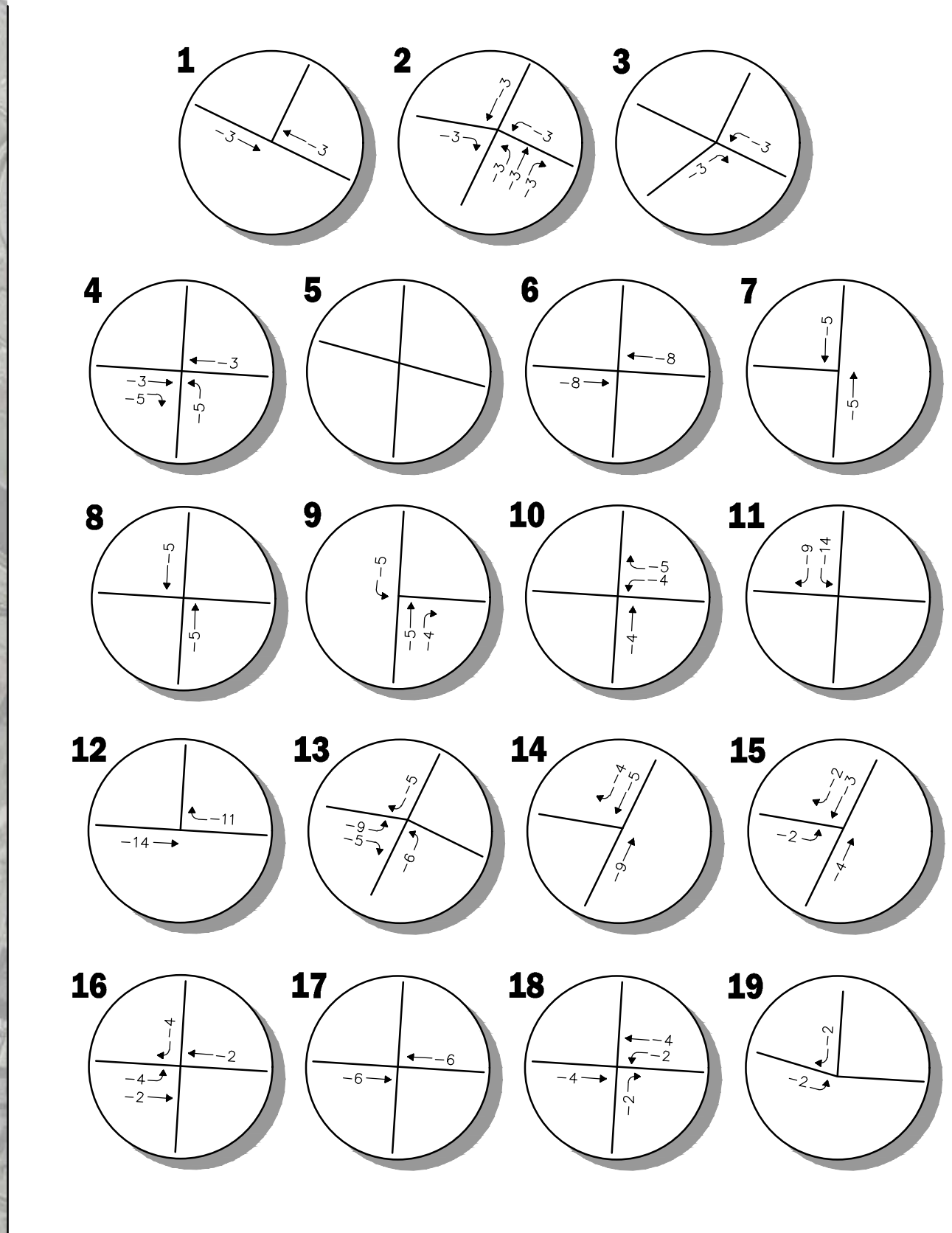
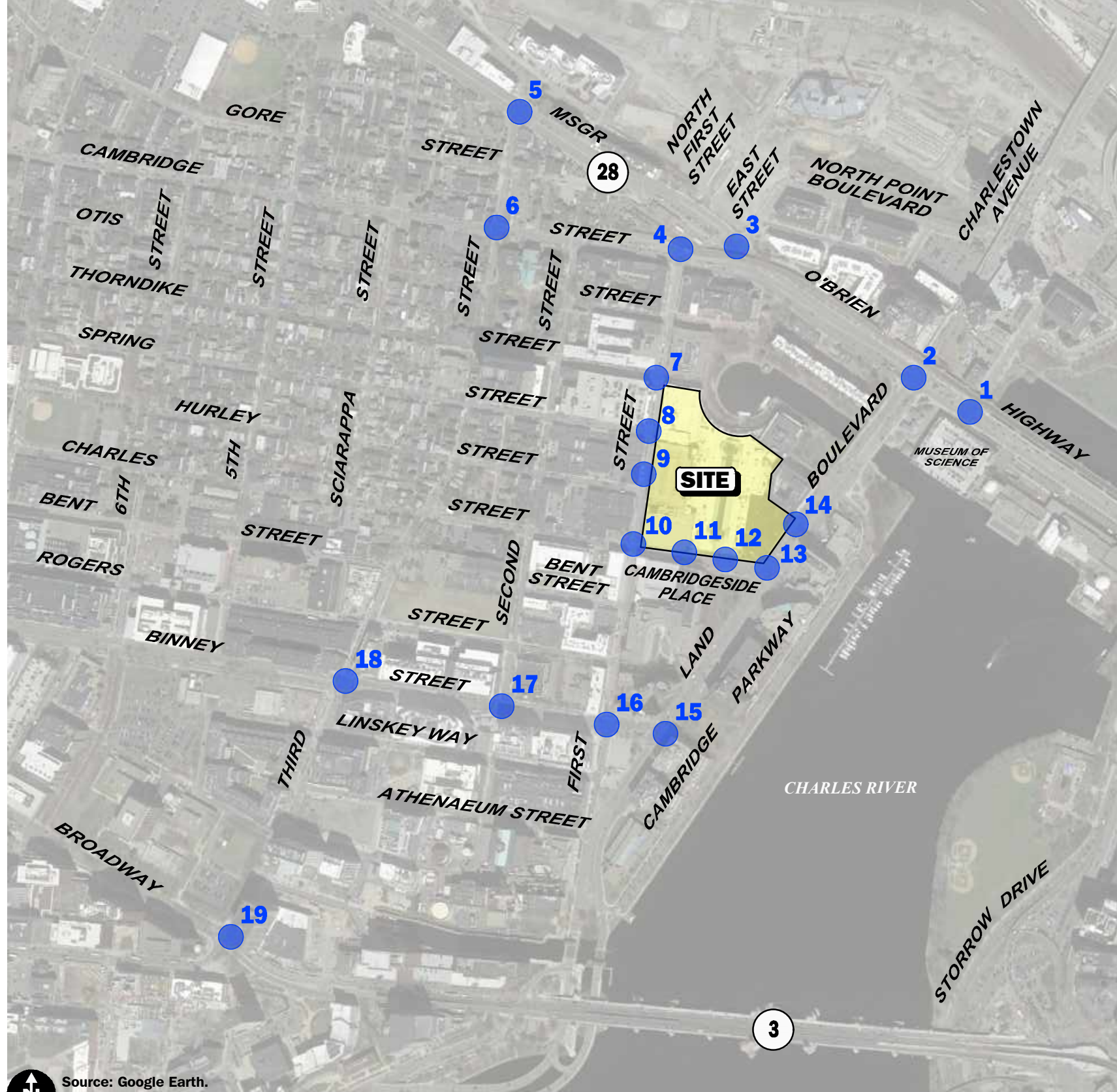


Figure 3.c.2
3rd Floor Retail Trips Removed
Weekday Evening
Peak Hour Traffic Volumes

Source: Google Earth.
 0 275 550 Scale in Feet



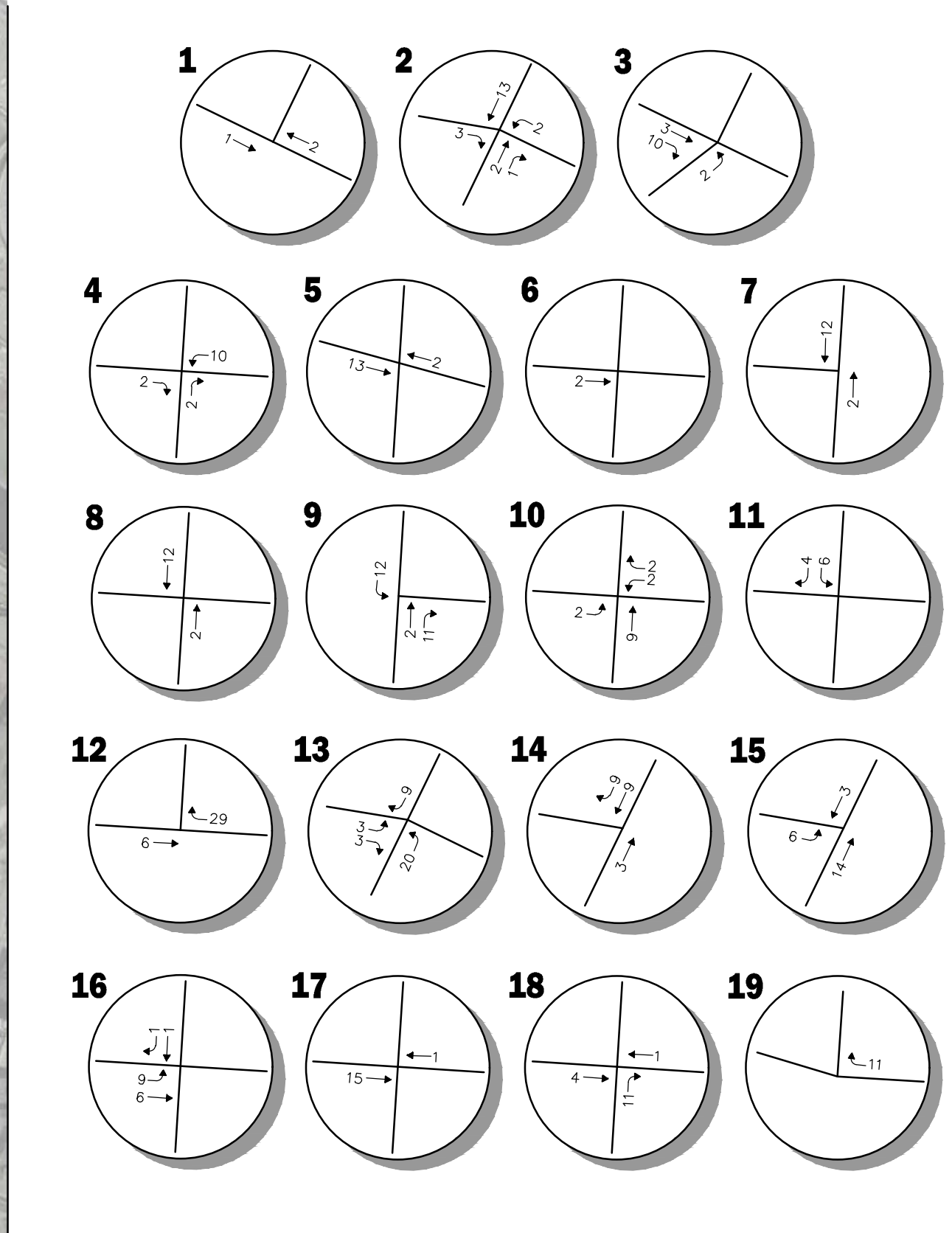
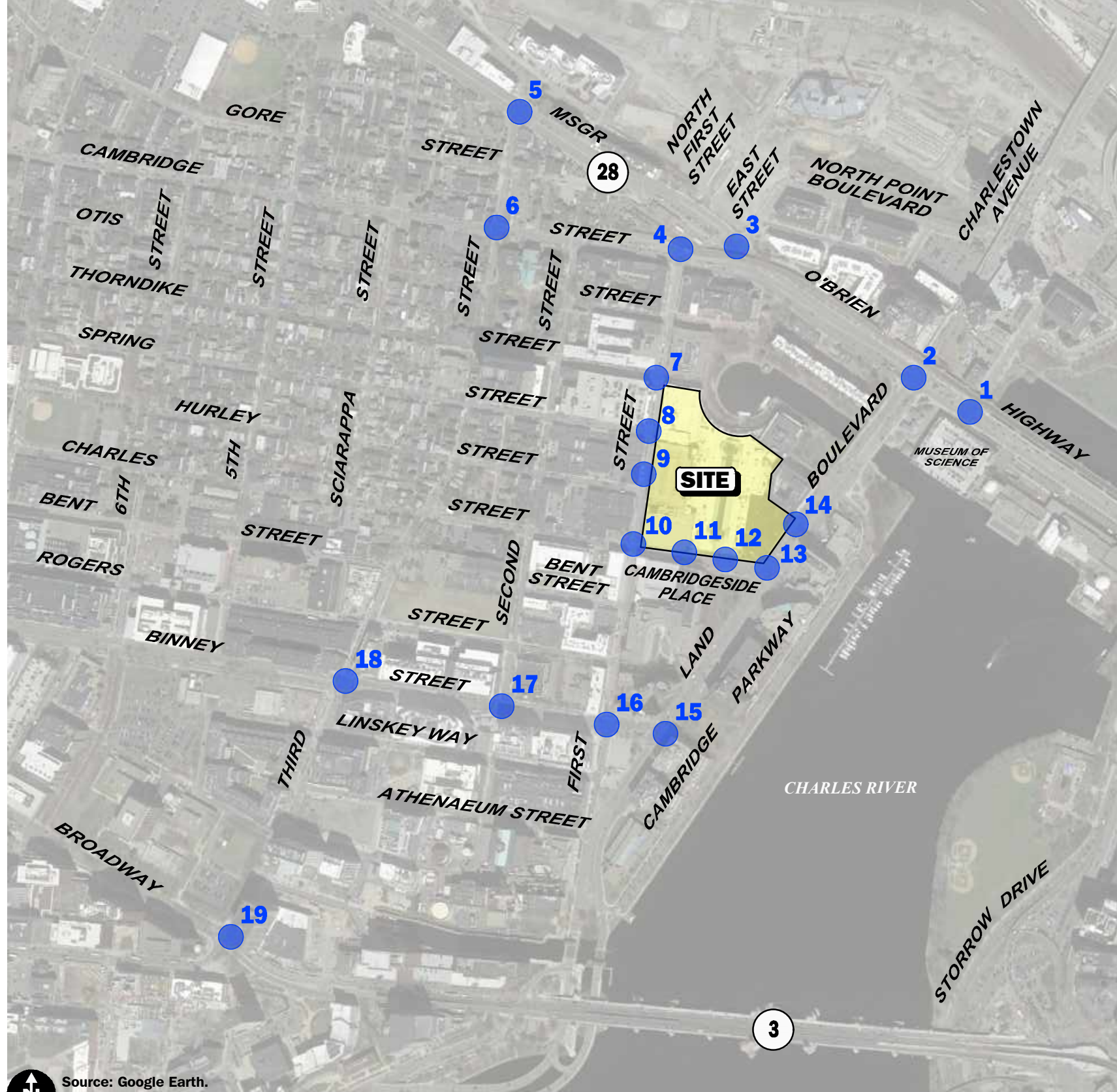


Figure 3.c.3
3rd Floor Office Trips
Weekday Morning
Peak Hour Traffic Volumes

Source: Google Earth.
 0 275 550 Scale in Feet



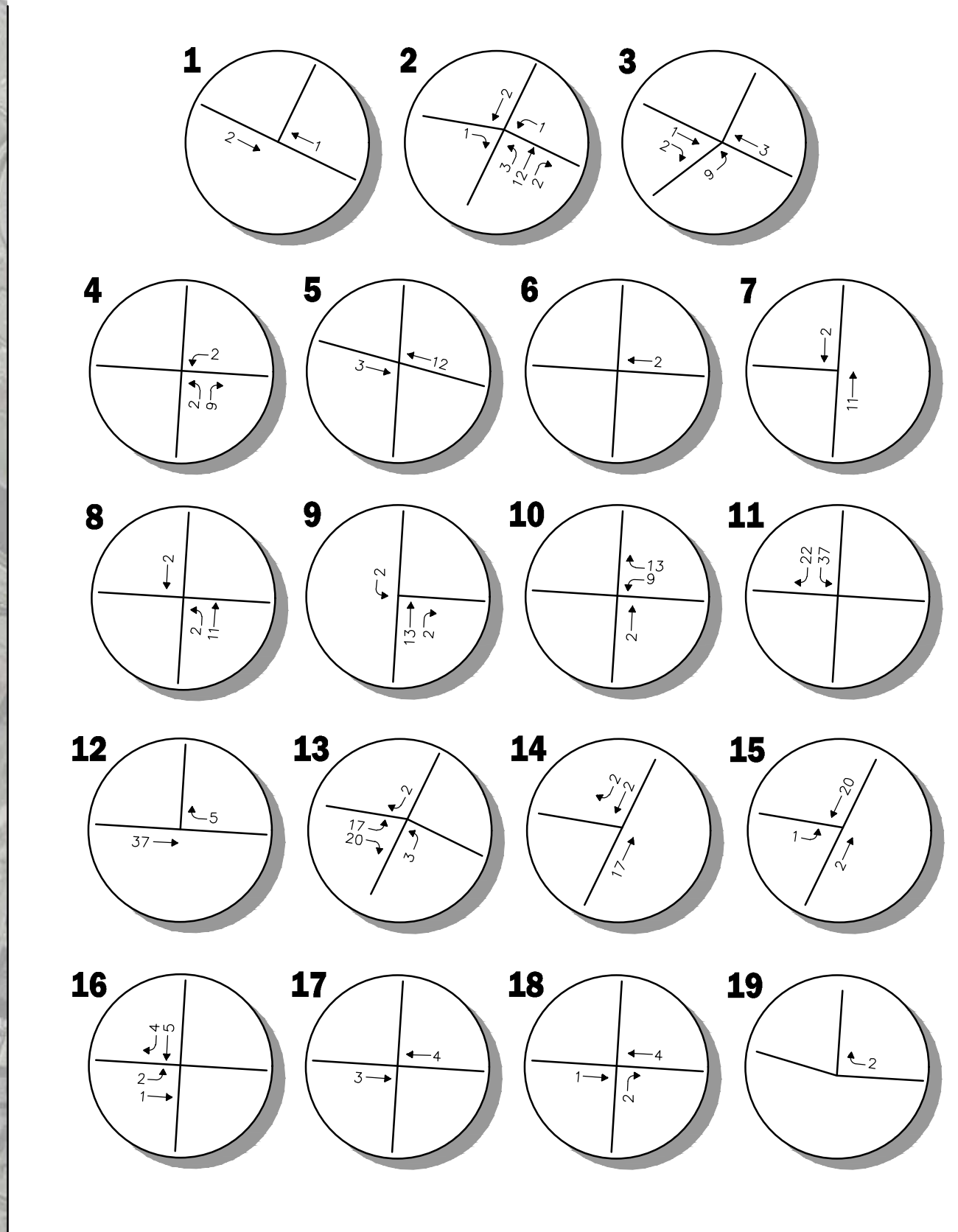
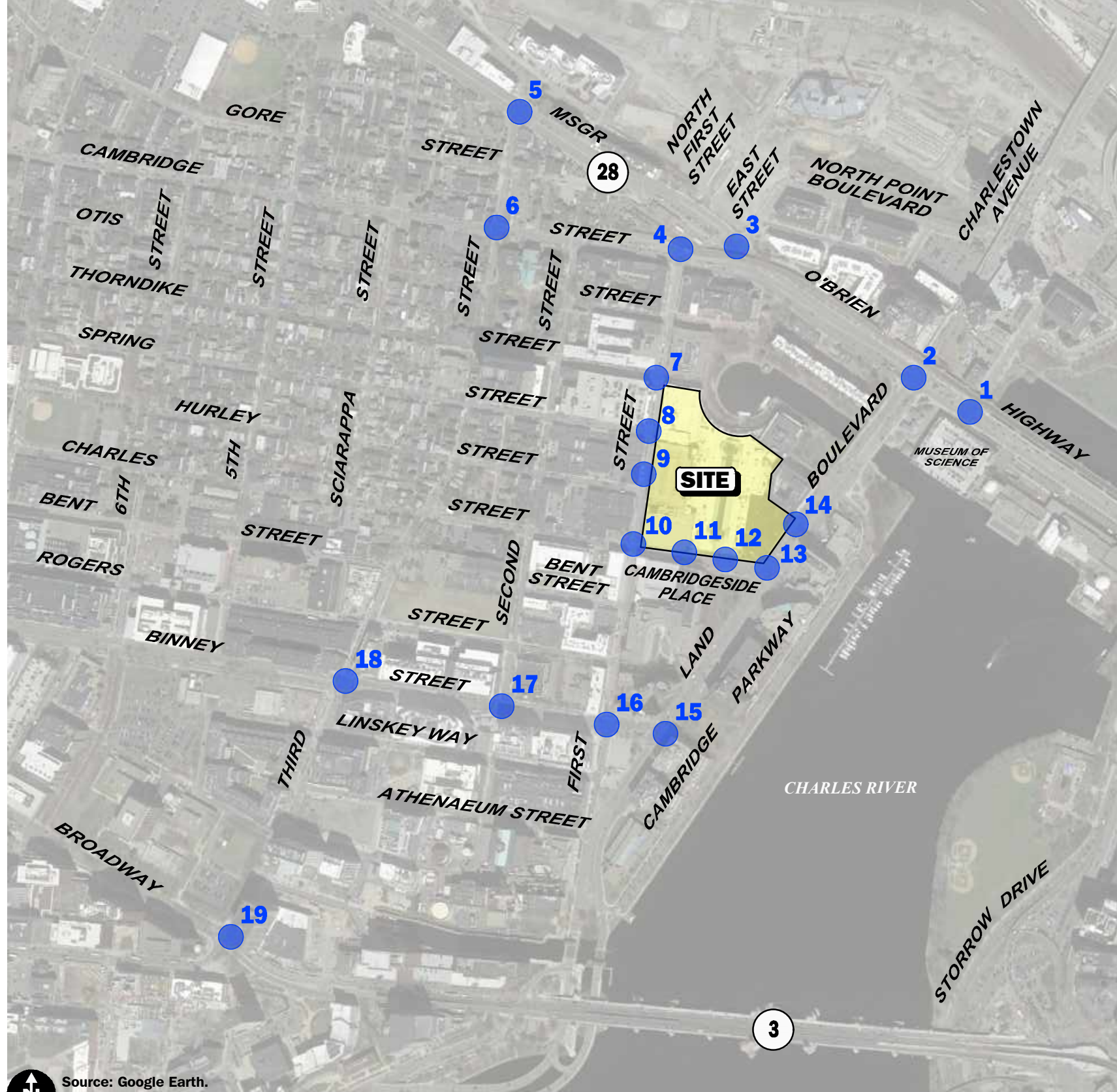
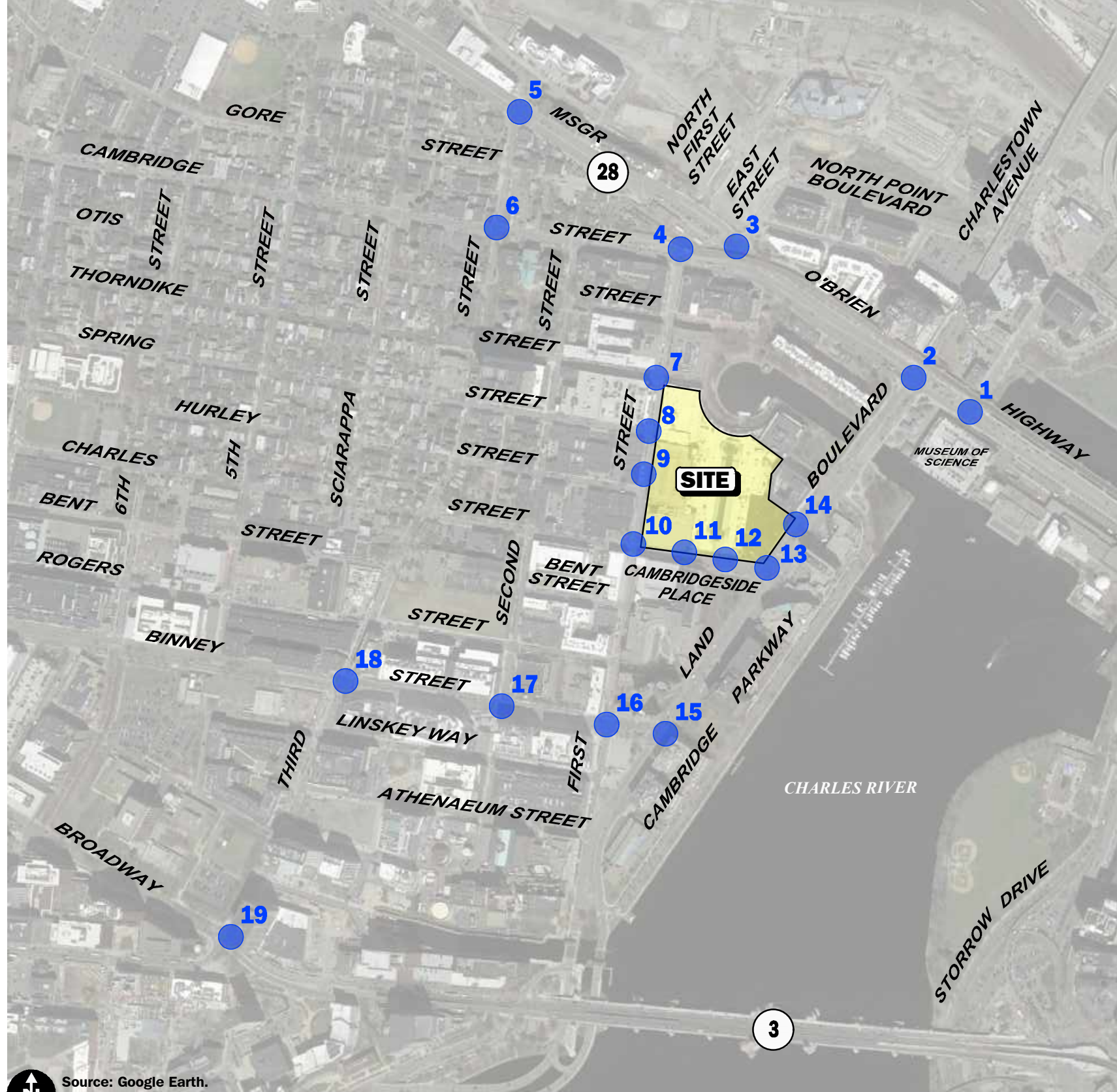


Figure 3.c.4
3rd Floor Office Trips
Weekday Evening
Peak Hour Traffic Volumes



Source: Google Earth.
 0 275 550 Scale in Feet

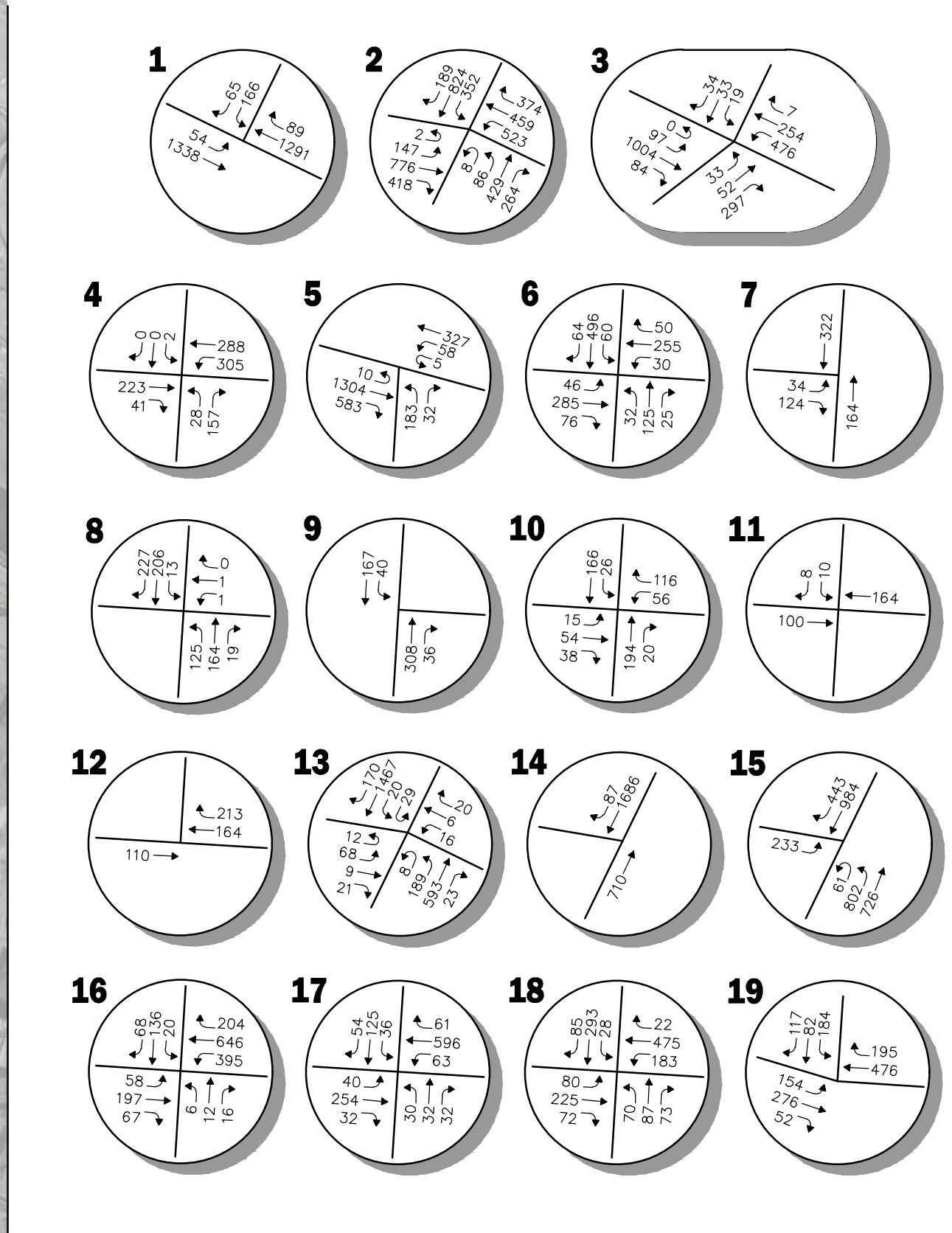
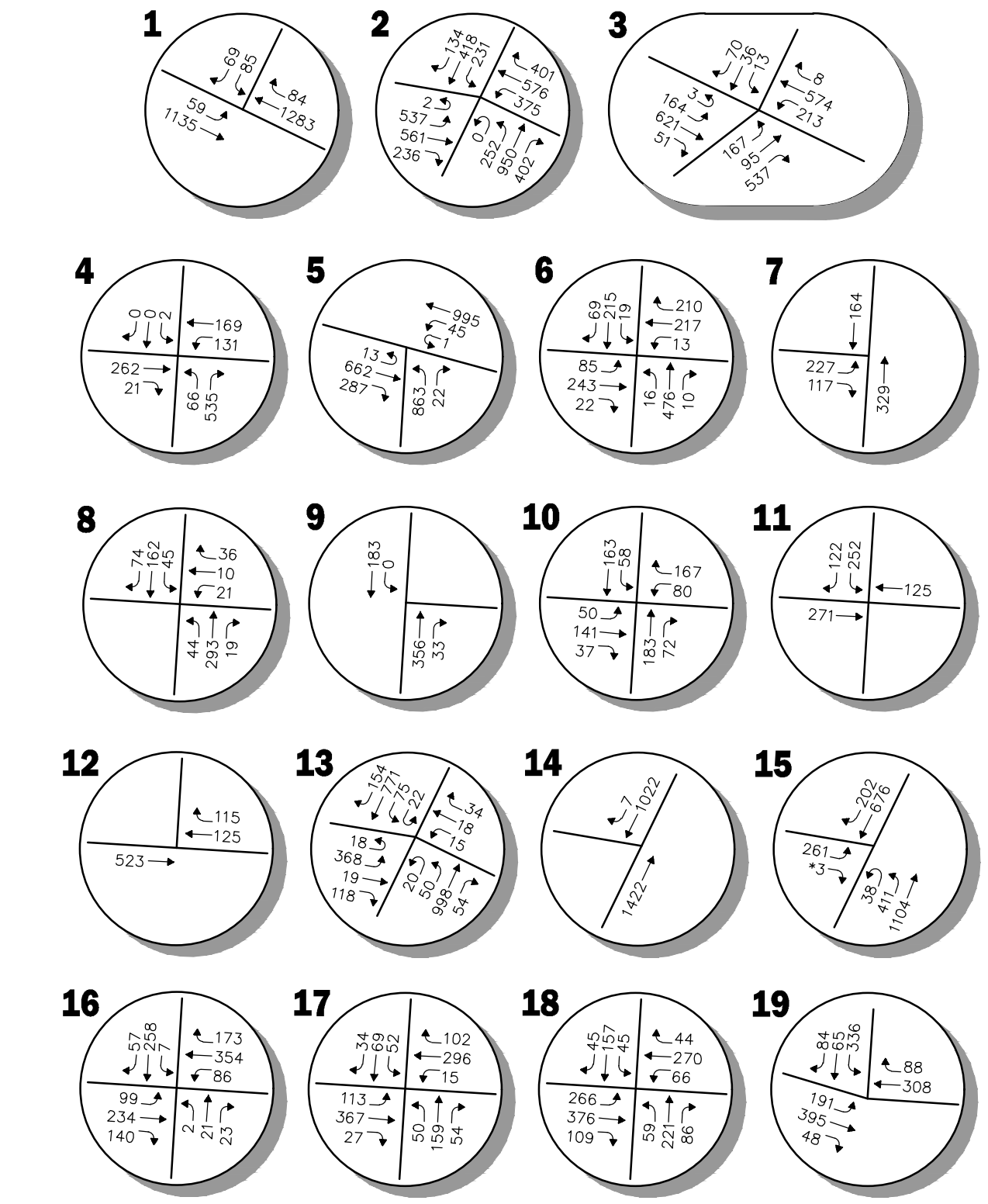


Figure 3.c.5
 2020 Modified Baseline
 Weekday Morning
 Peak Hour Traffic Volumes



*Illegal movement.

Figure 3.c.6
 2020 Modified Baseline
 Weekday Evening
 Peak Hour Traffic Volumes

R:\17810\Cambridgeside 2.0\17810\10NT2.dwg, 7/19/2020 12:36:05 PM

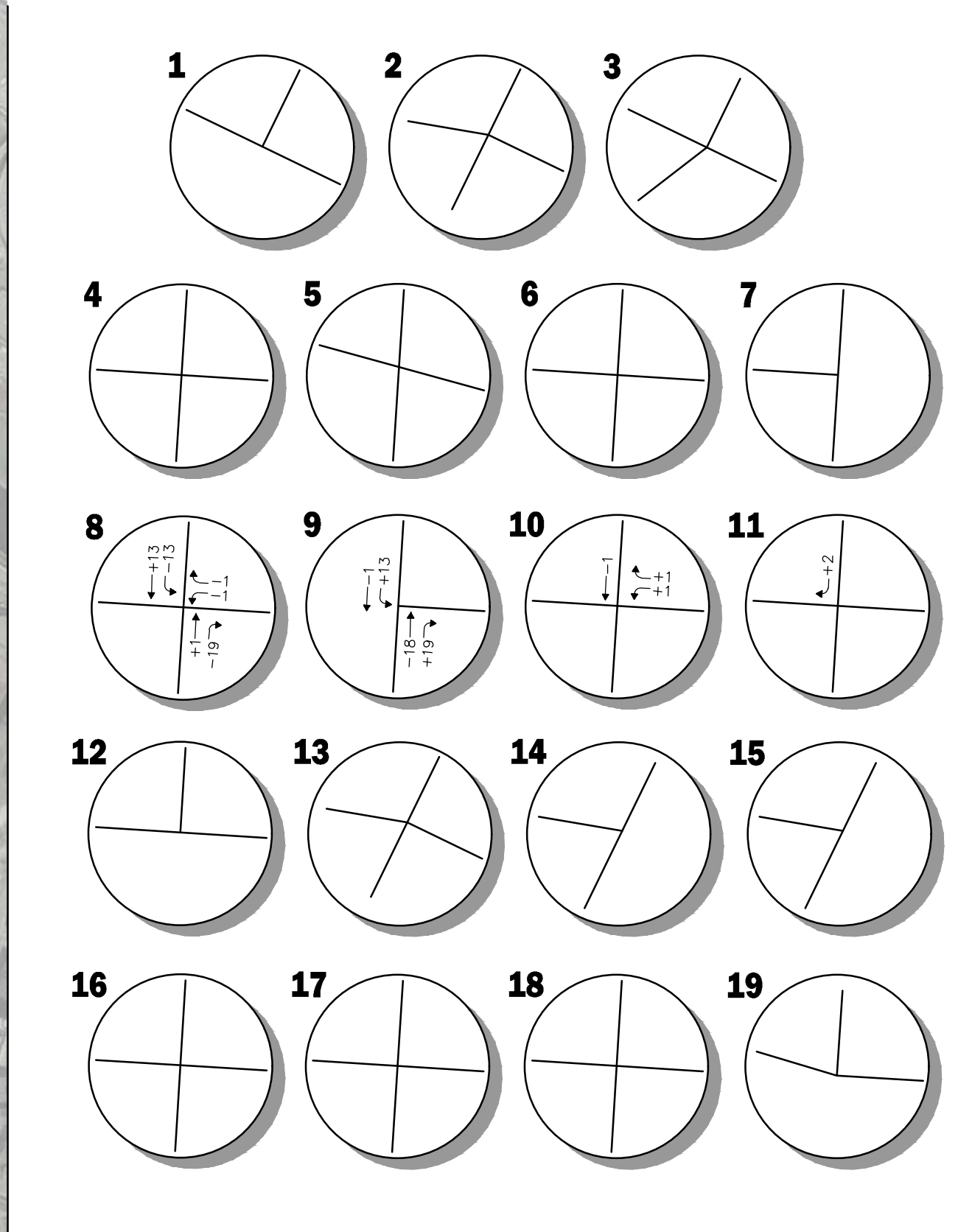
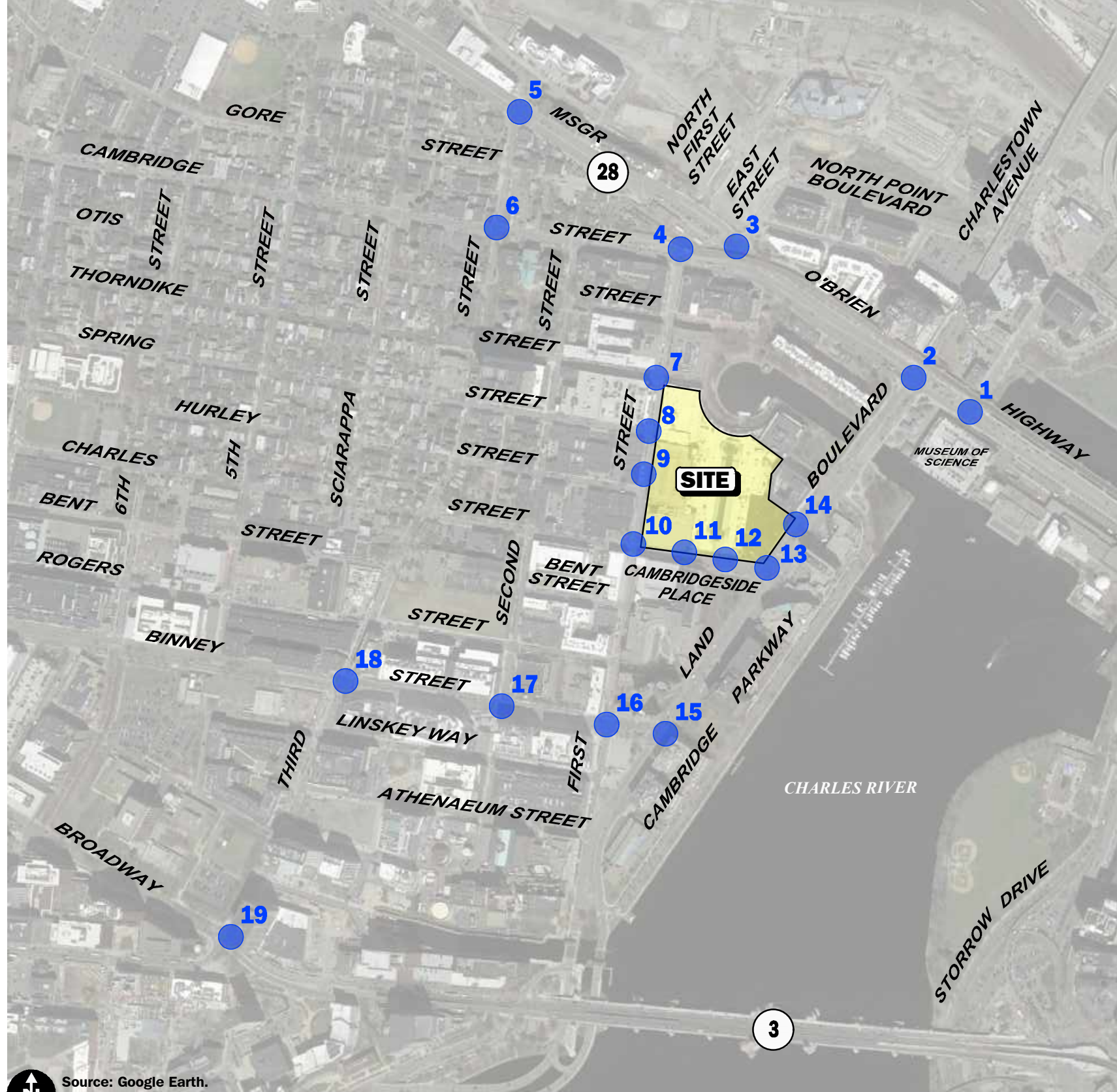


Figure 3.d.1

Upper Garage
Weekday Morning
Relocated Trips

Source: Google Earth.
0 275 550 Scale in Feet



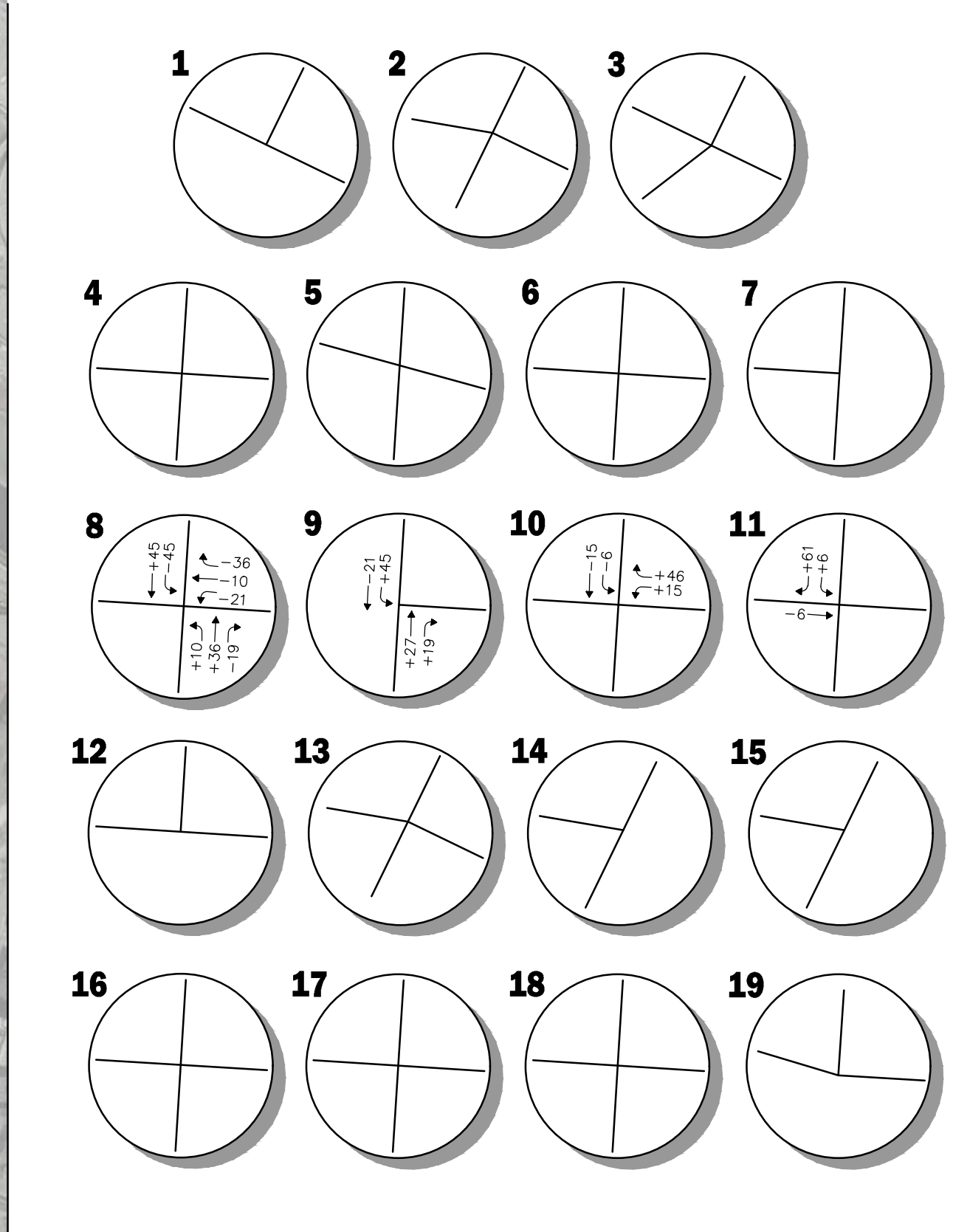
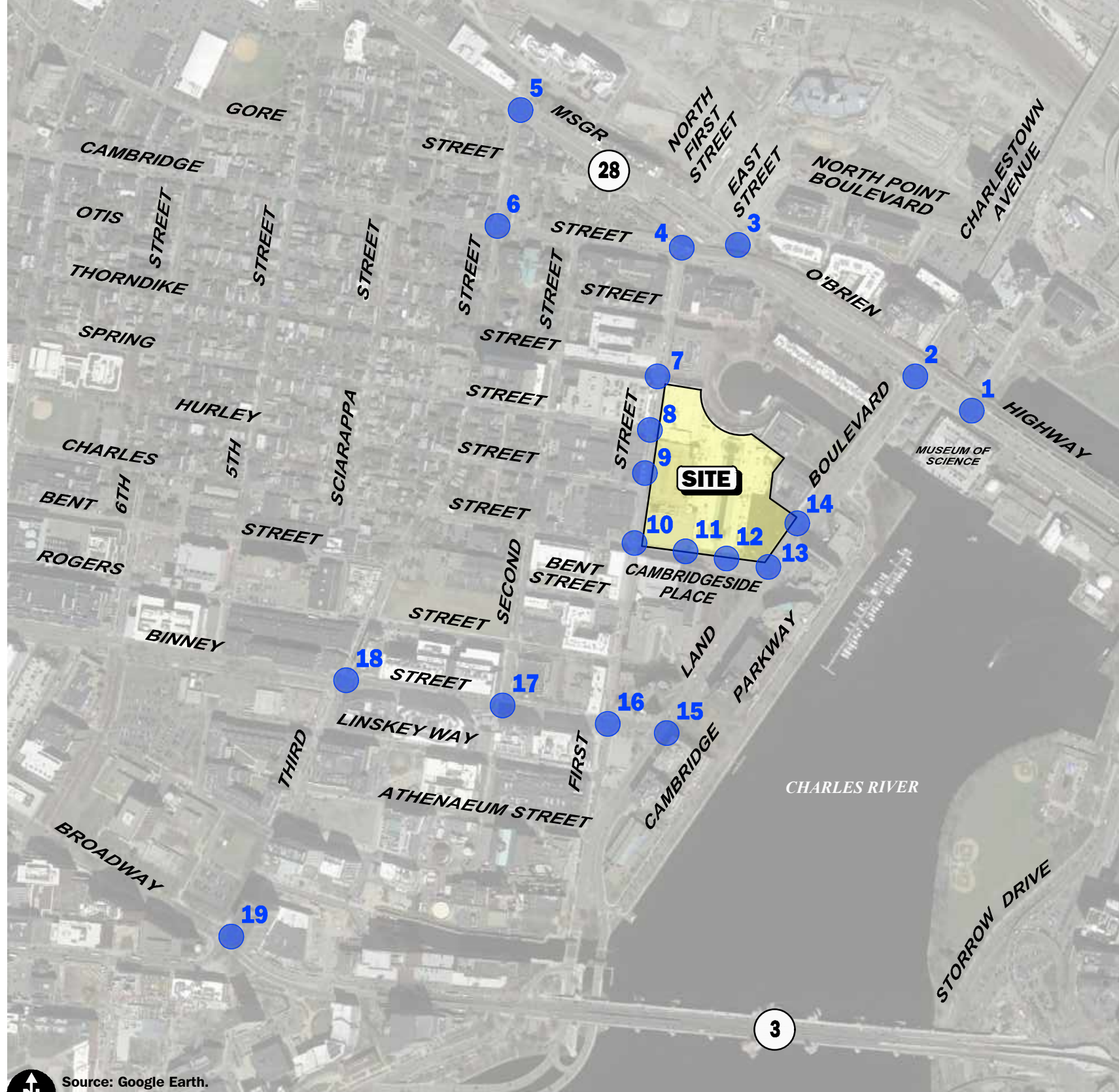
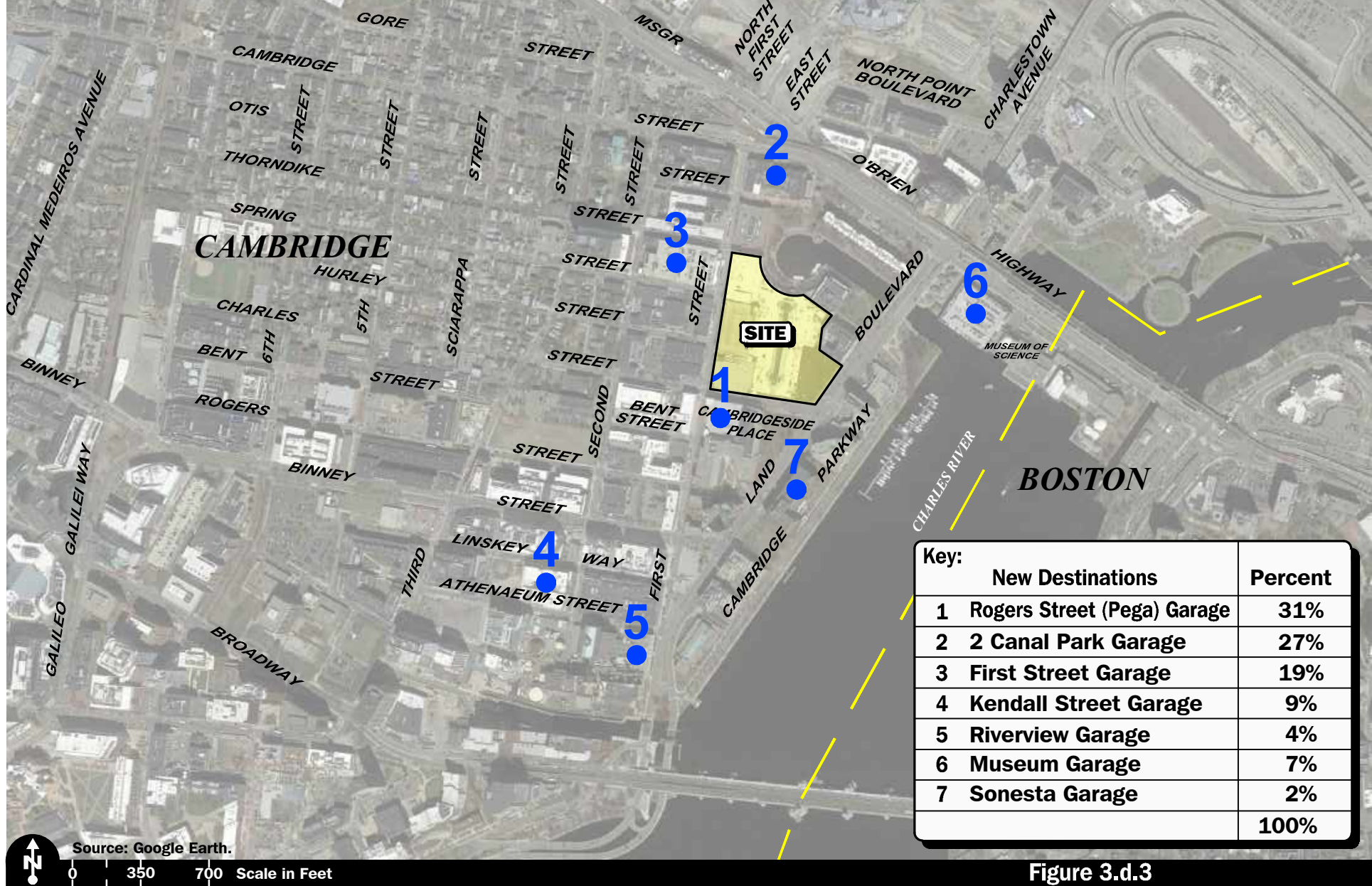


Figure 3.d.2
Upper Garage
Weekday Evening
Relocated Trips



Key:		New Destinations	Percent
1	Rogers Street (Pega) Garage		31%
2	2 Canal Park Garage		27%
3	First Street Garage		19%
4	Kendall Street Garage		9%
5	Riverview Garage		4%
6	Museum Garage		7%
7	Sonesta Garage		2%
			100%

Figure 3.d.3

New Destinations for Monthly Parkers



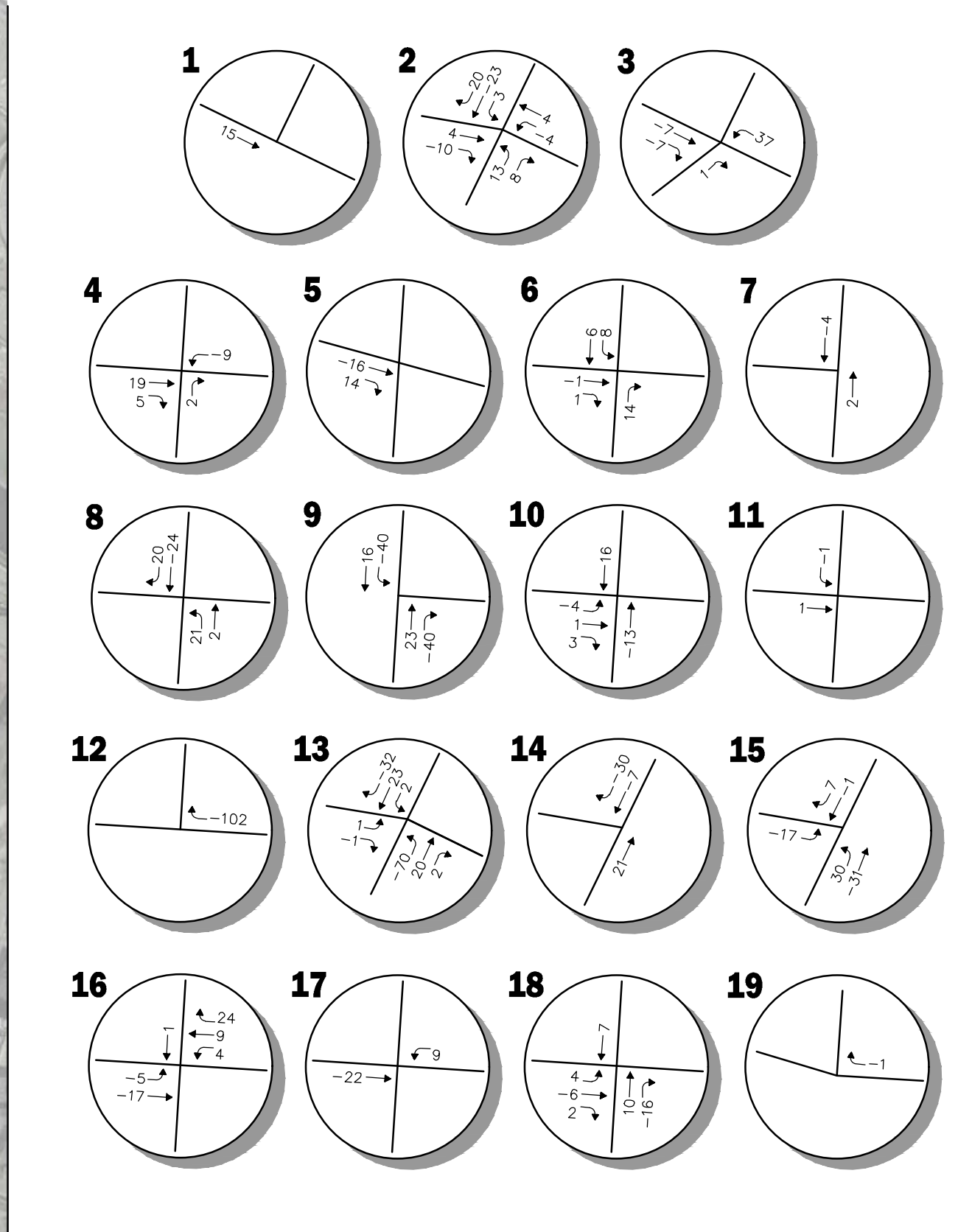
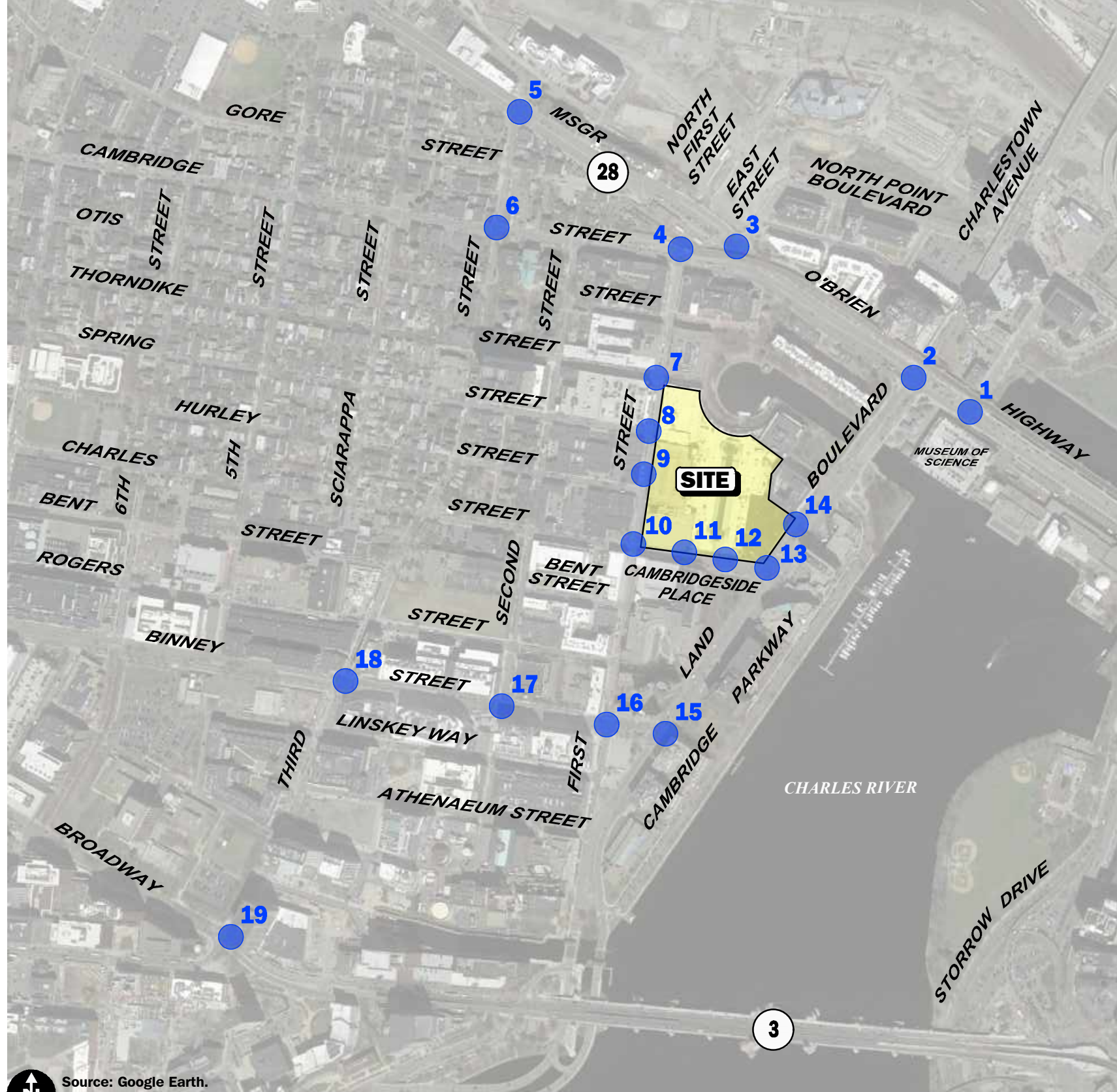


Figure 3.d.4a
 Net Non-Tenant Monthly Parkers
 Redistributed
 Weekday Morning
 Peak Hour Traffic Volumes

R:\7810\Cambridgeside 2.0\7810\NT4.dwg, 7/22/2020 9:05:19 AM

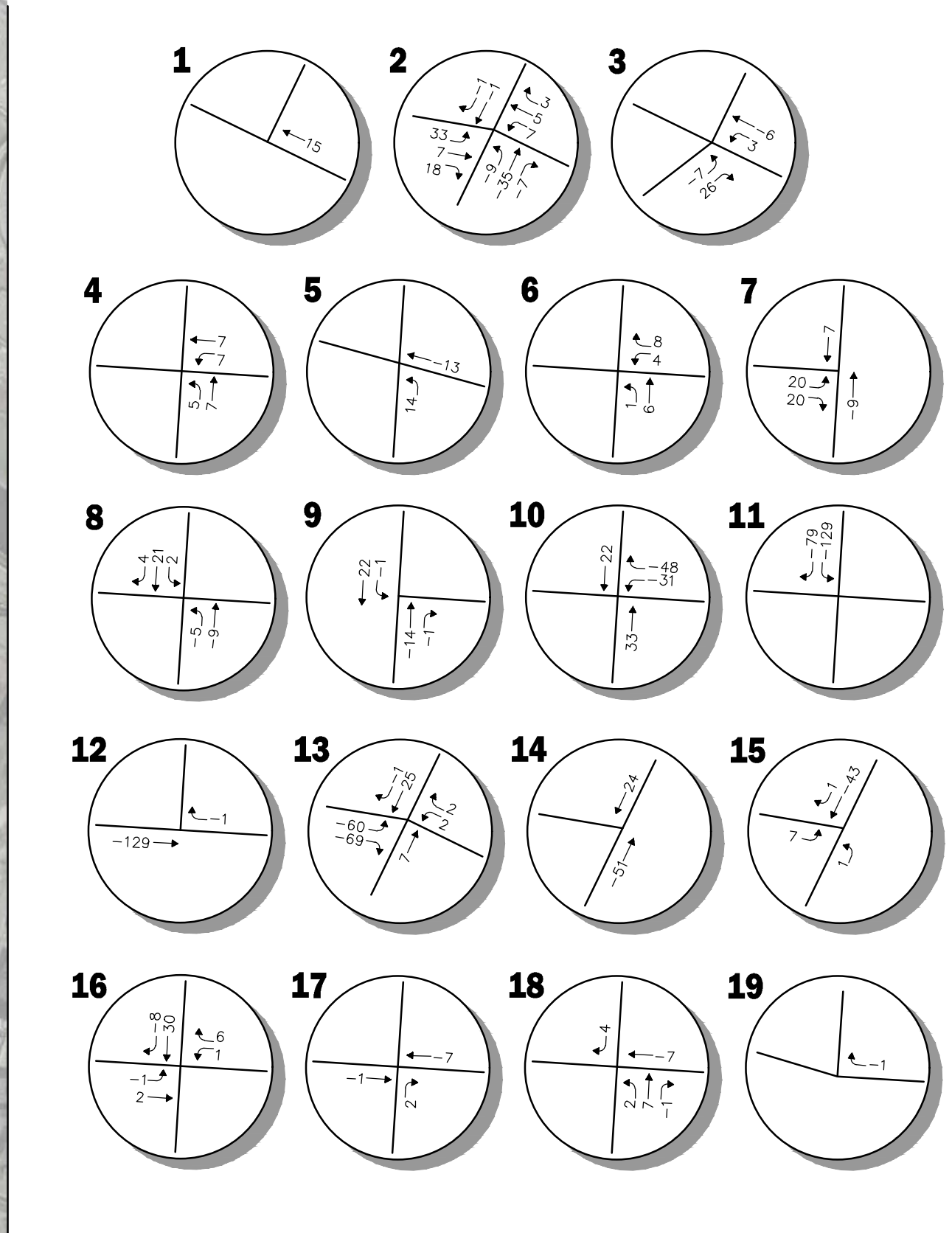
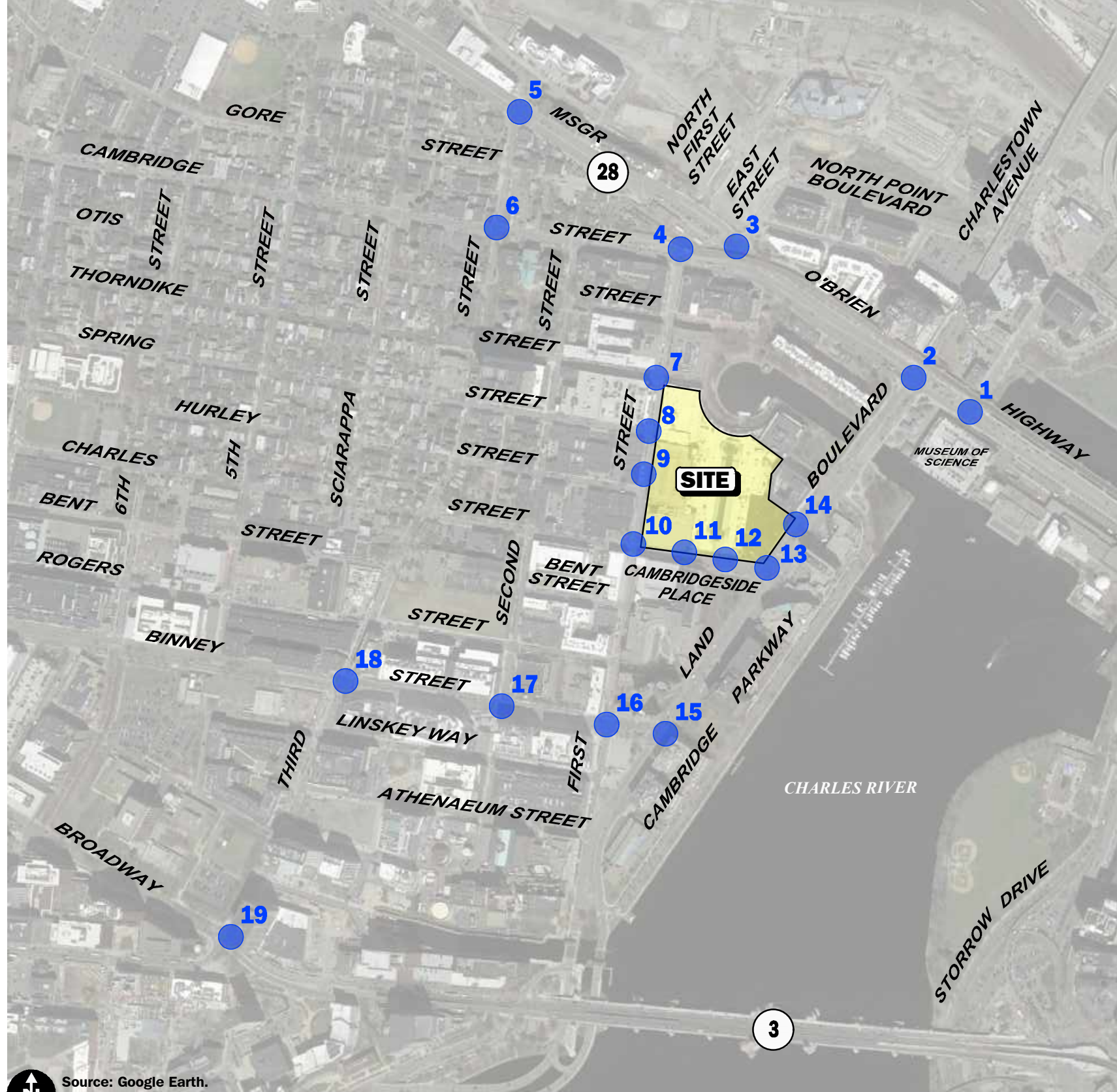


Figure 3.d.4b
 Net Non-Tenant Monthly Parkers
 Redistributed
 Weekday Evening
 Peak Hour Traffic Volumes

R:\7810\Cambridgeside 2.0\7810\NT4.dwg, 7/22/2020 9:06:07 AM

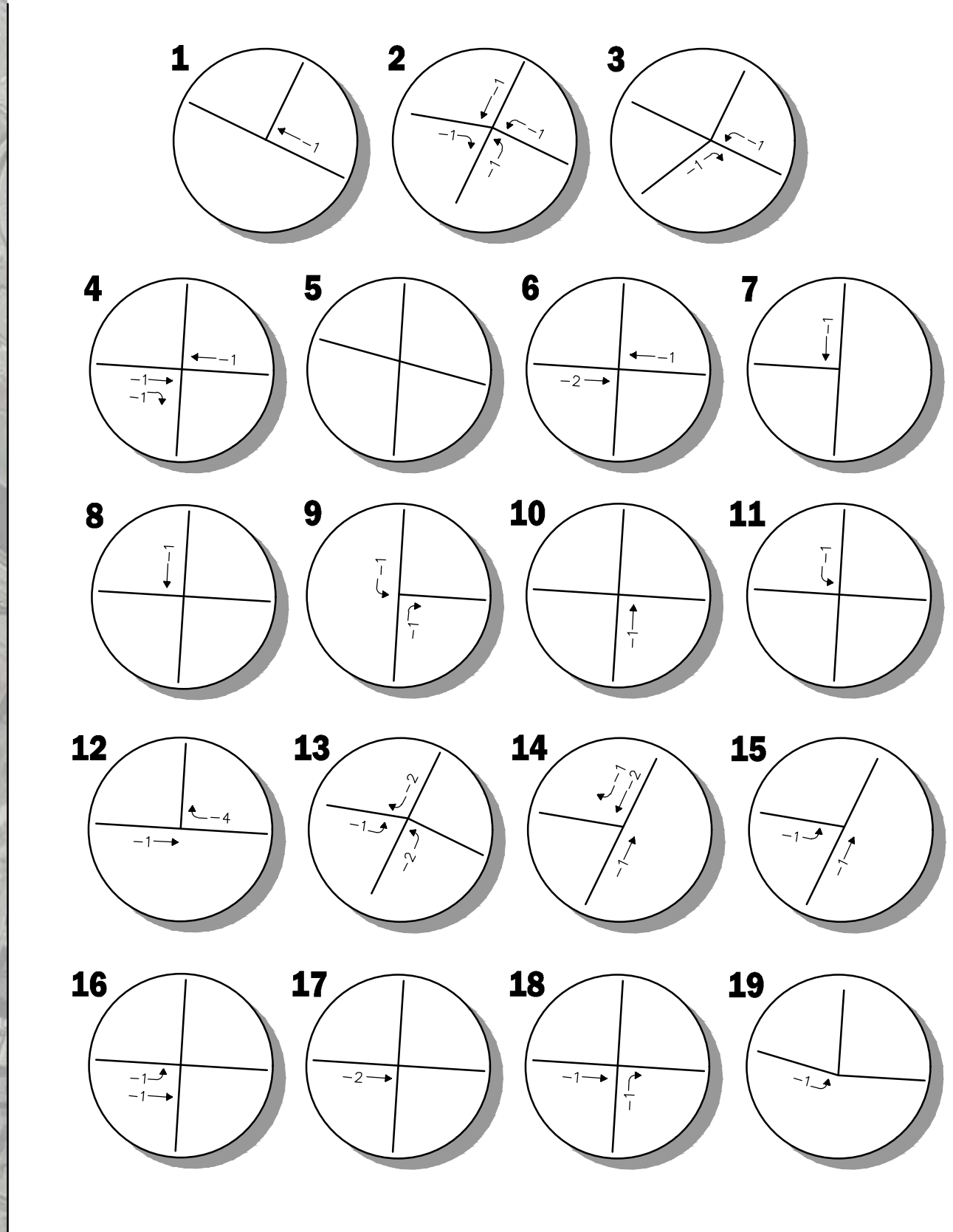
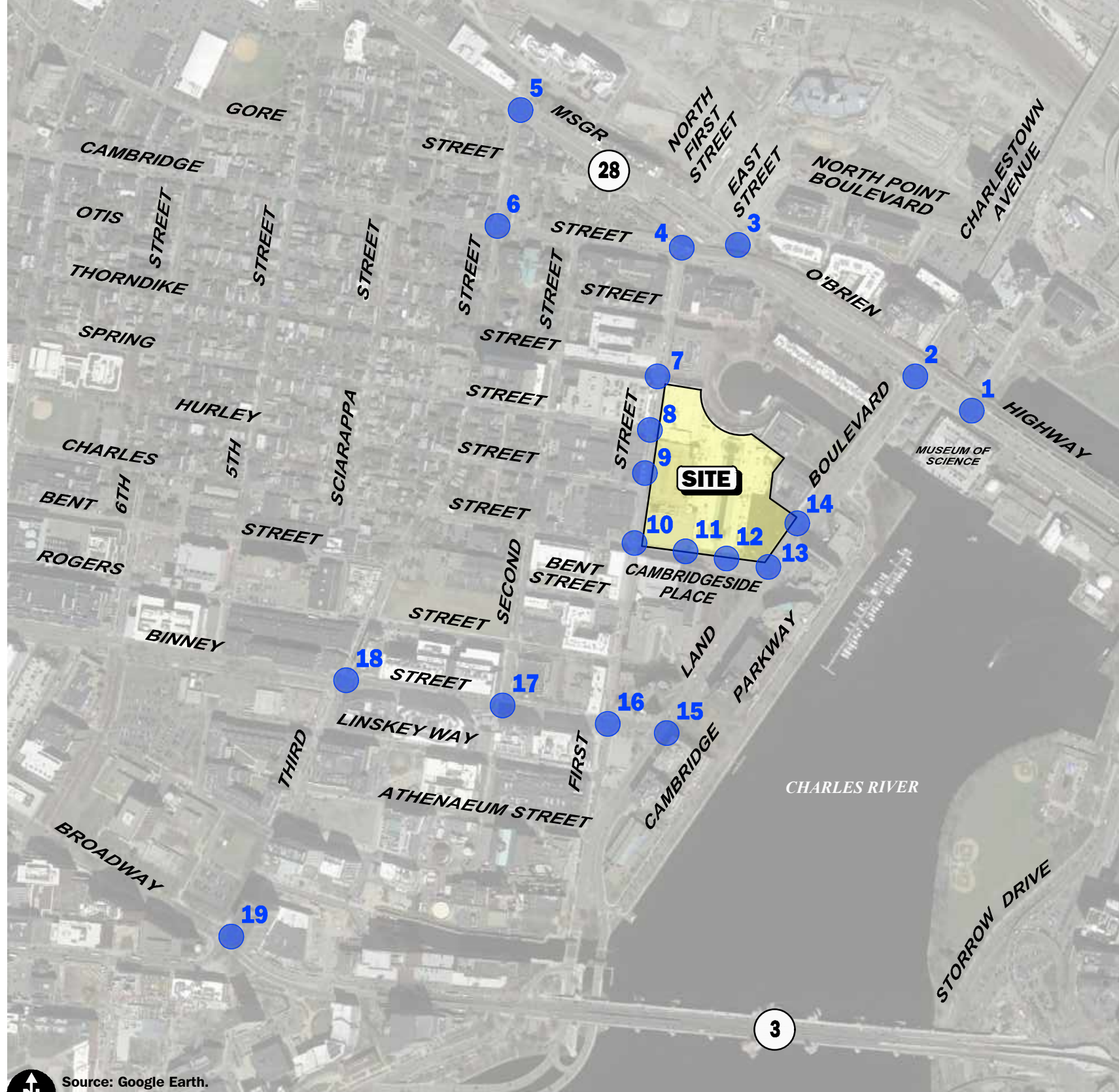


Figure 3.d.5
Core Retail Trips Removed
Weekday Morning
Peak Hour Traffic Volumes

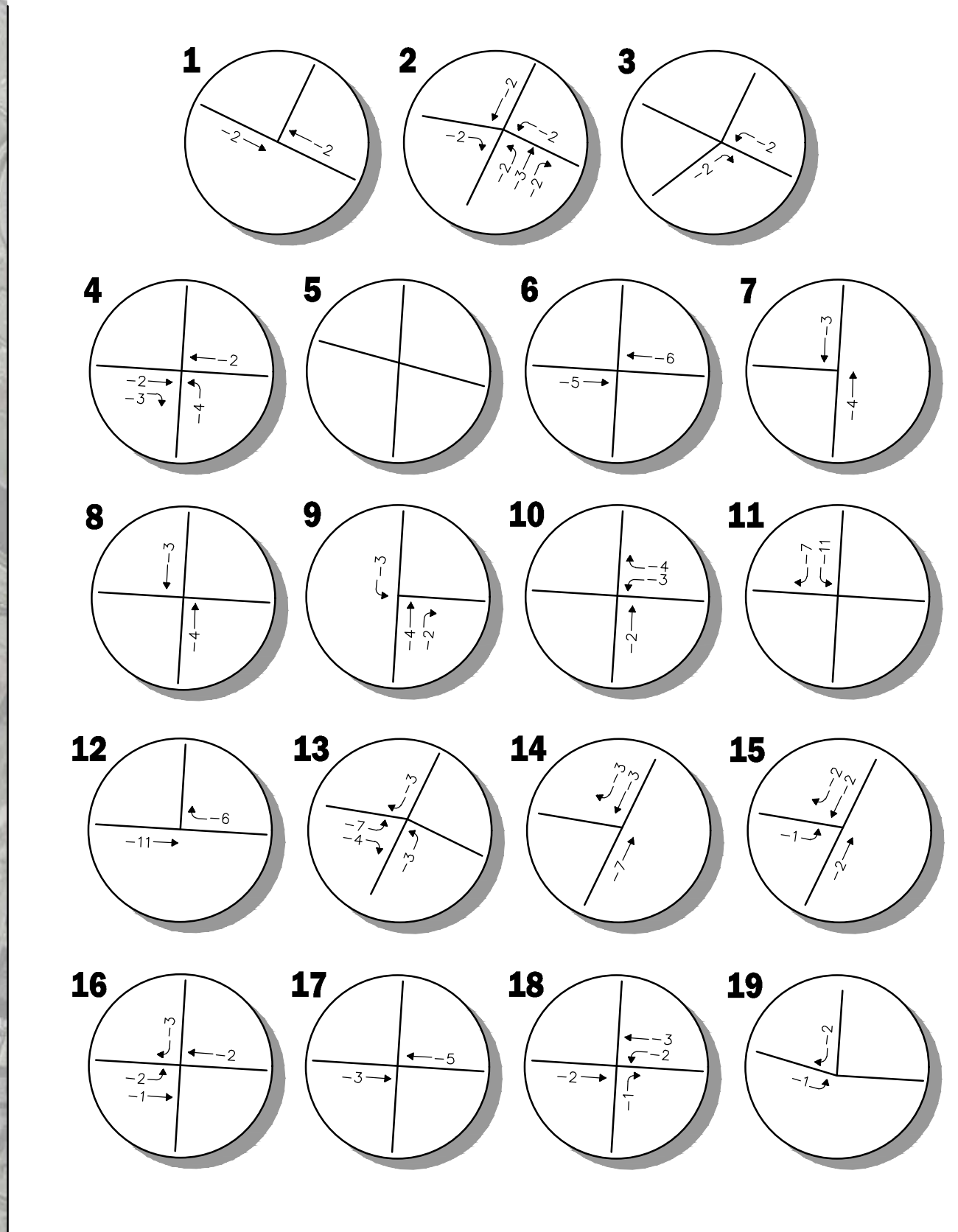
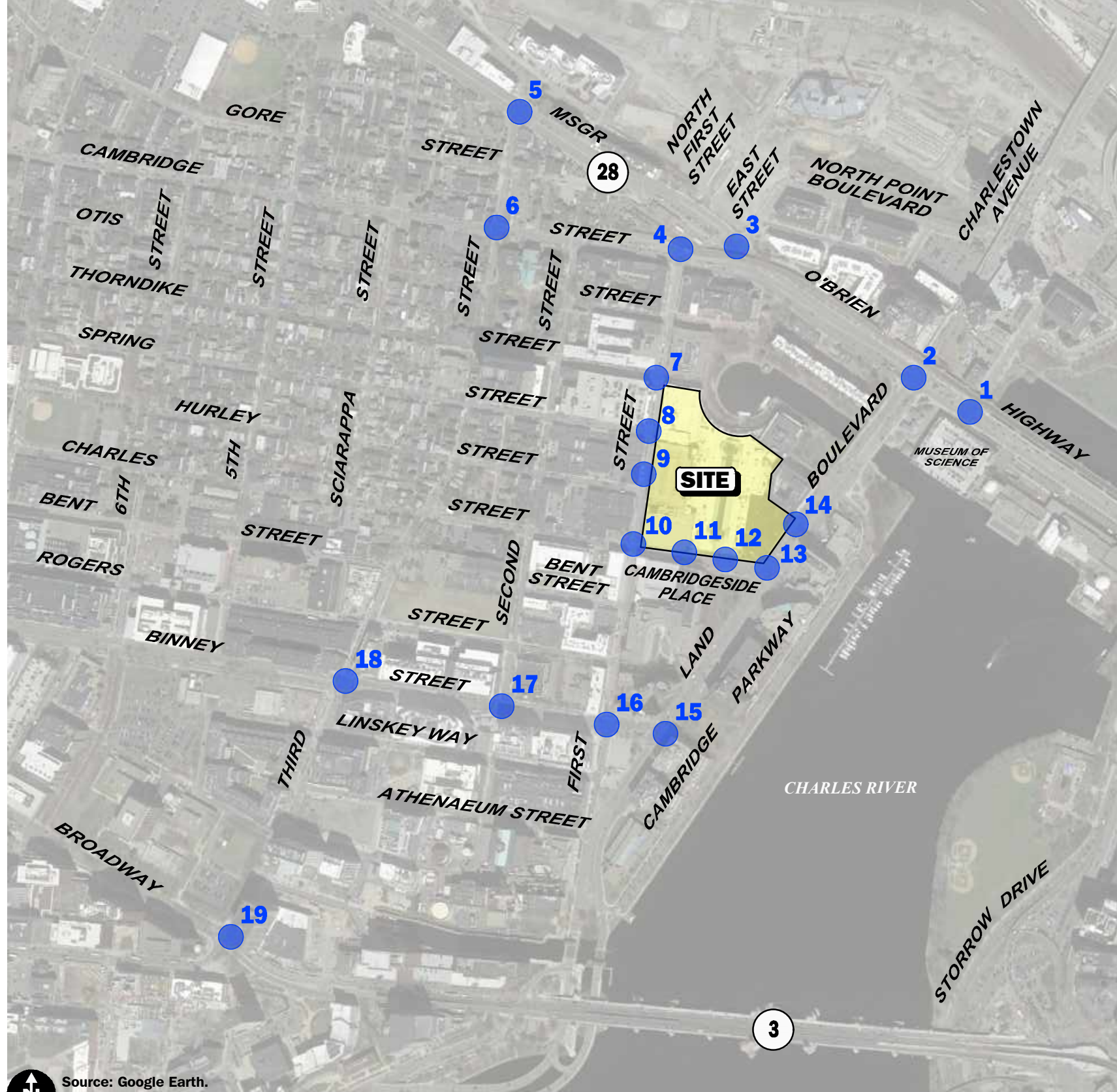


Figure 3.d.6
Core Retail Trips Removed
Weekday Evening
Peak Hour Traffic Volumes

R:\7810\Cambridgeside 2.0\7810\NT4.dwg, 7/9/2020 12:41:23 PM

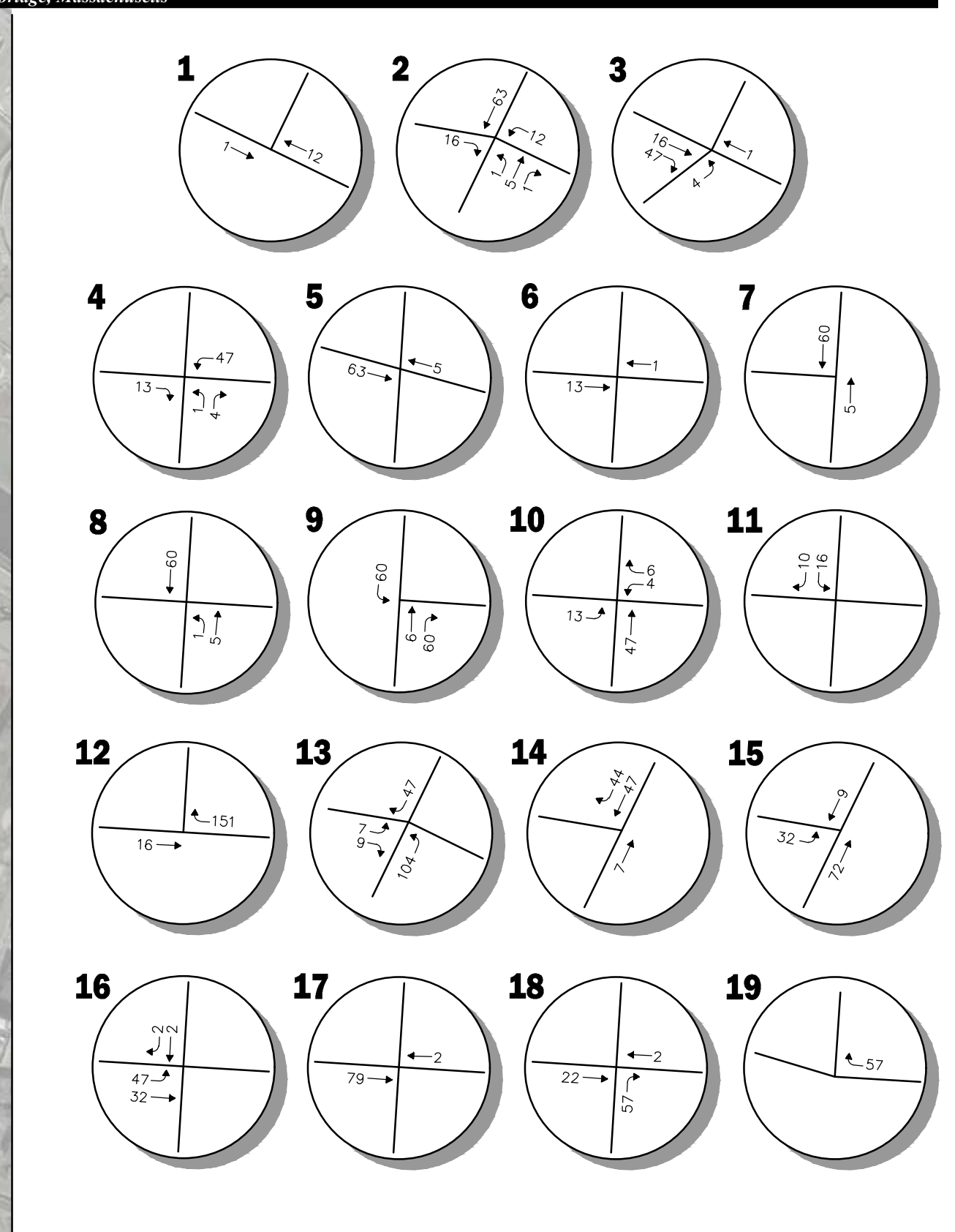


Figure 3.d.7
Office / R&D Trips
Weekday Morning
Peak Hour Traffic Volumes

R:\7810\Cambridgeside 2.0\7810\NT4.dwg, 7/19/2020 12:42:08 PM

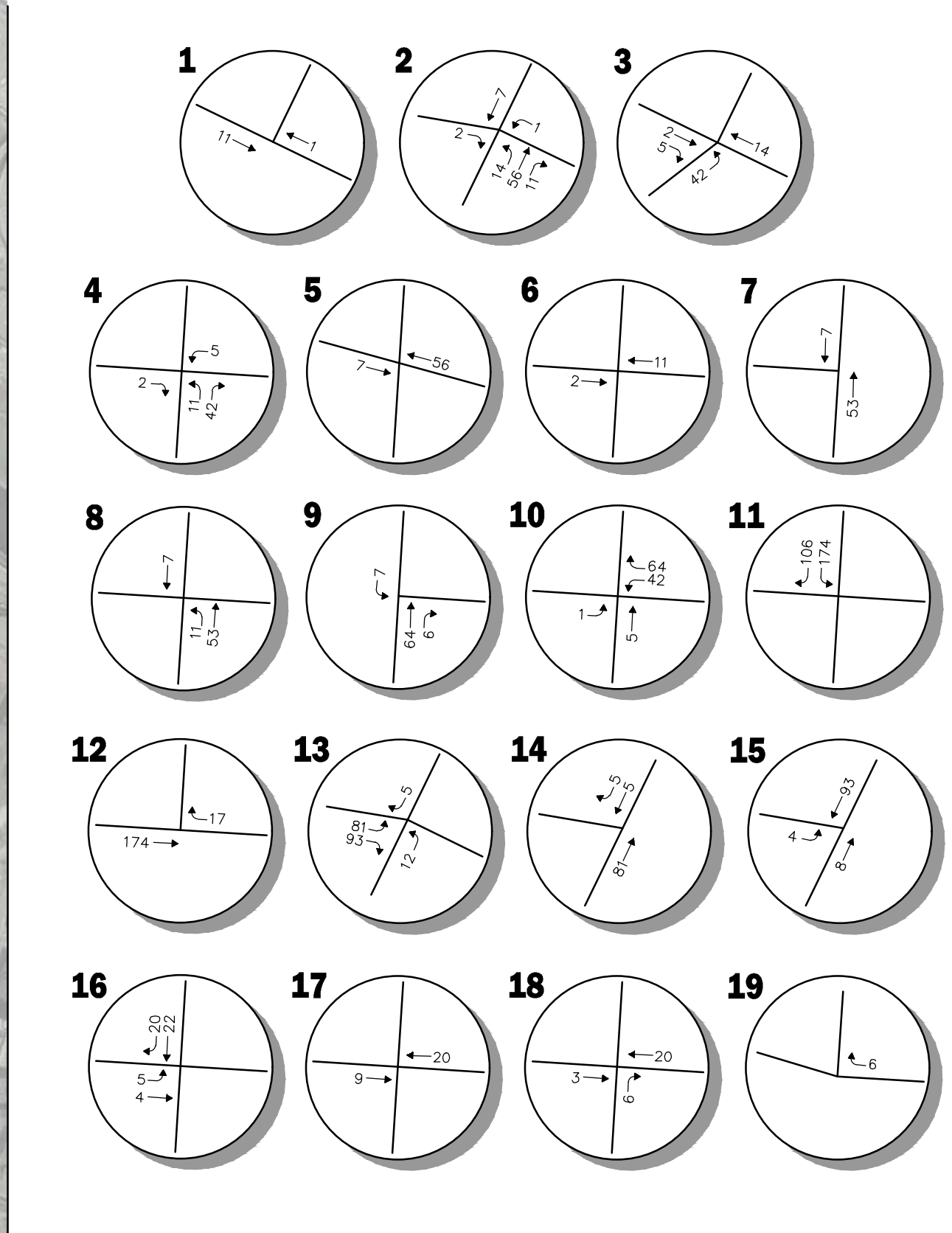
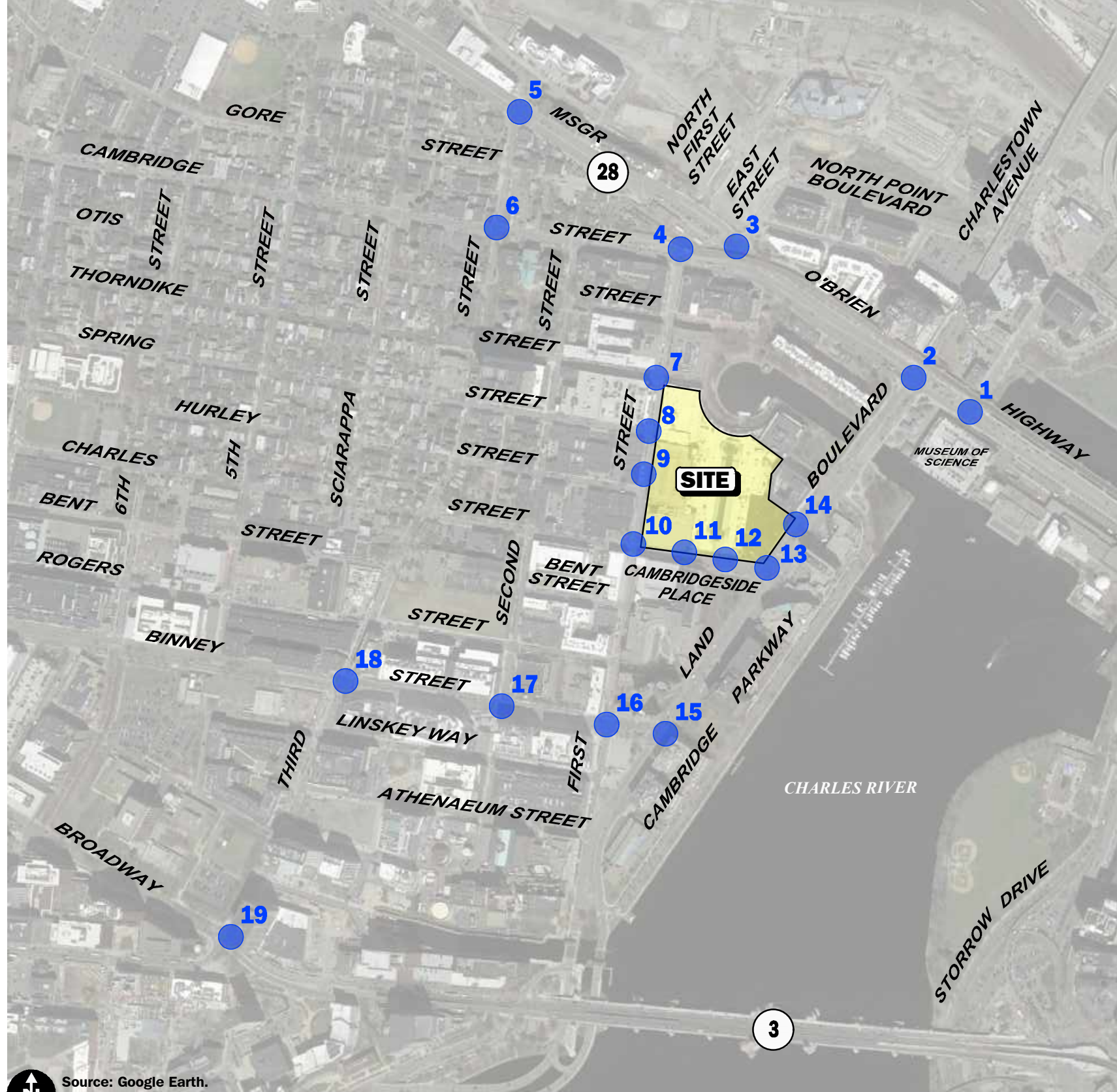


Figure 3.d.8
Office / R&D Trips
Weekday Evening
Peak Hour Traffic Volumes

R:\7810\Cambridgeside 2.0\7810\NT4.dwg, 7/9/2020 12:42:46 PM

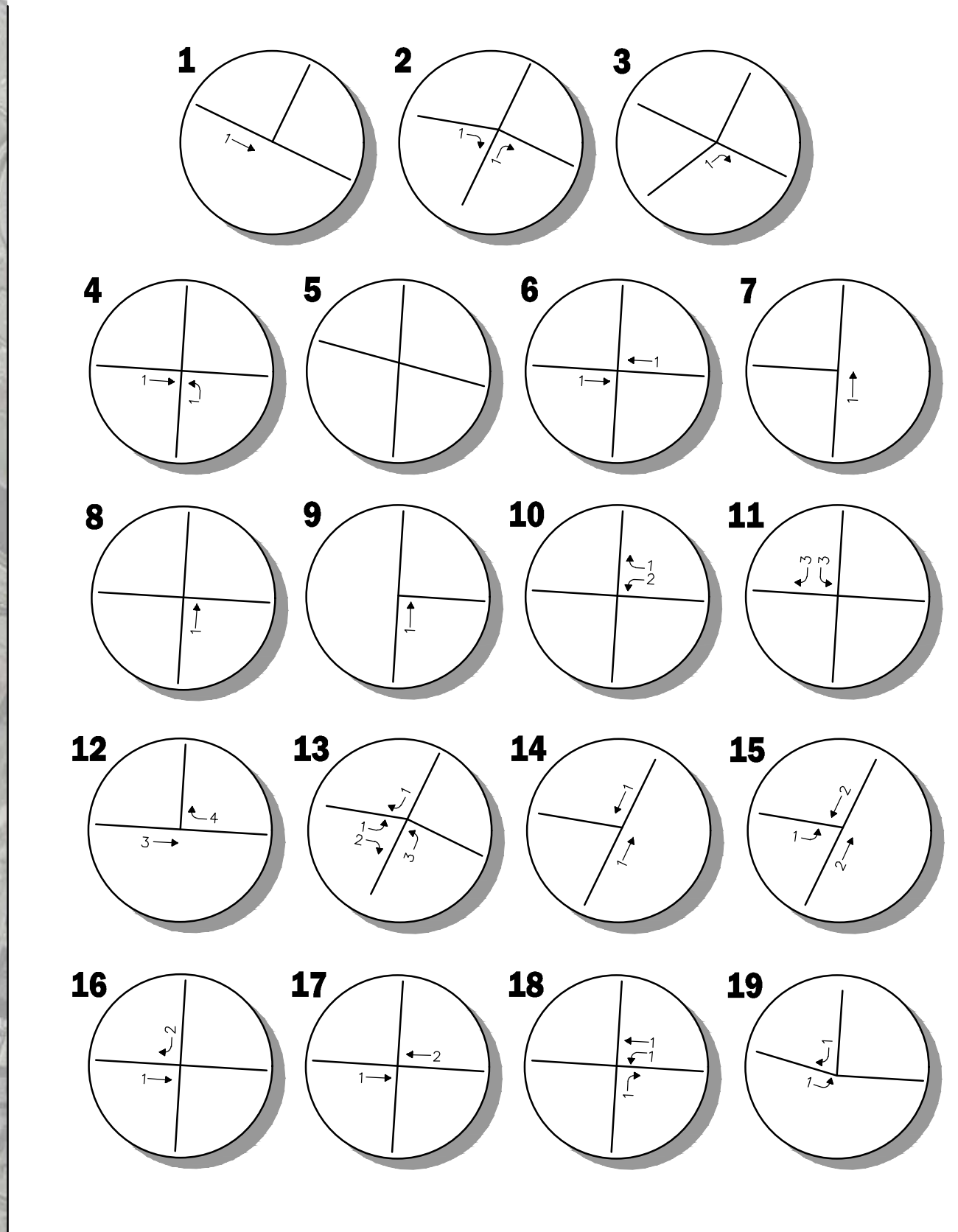
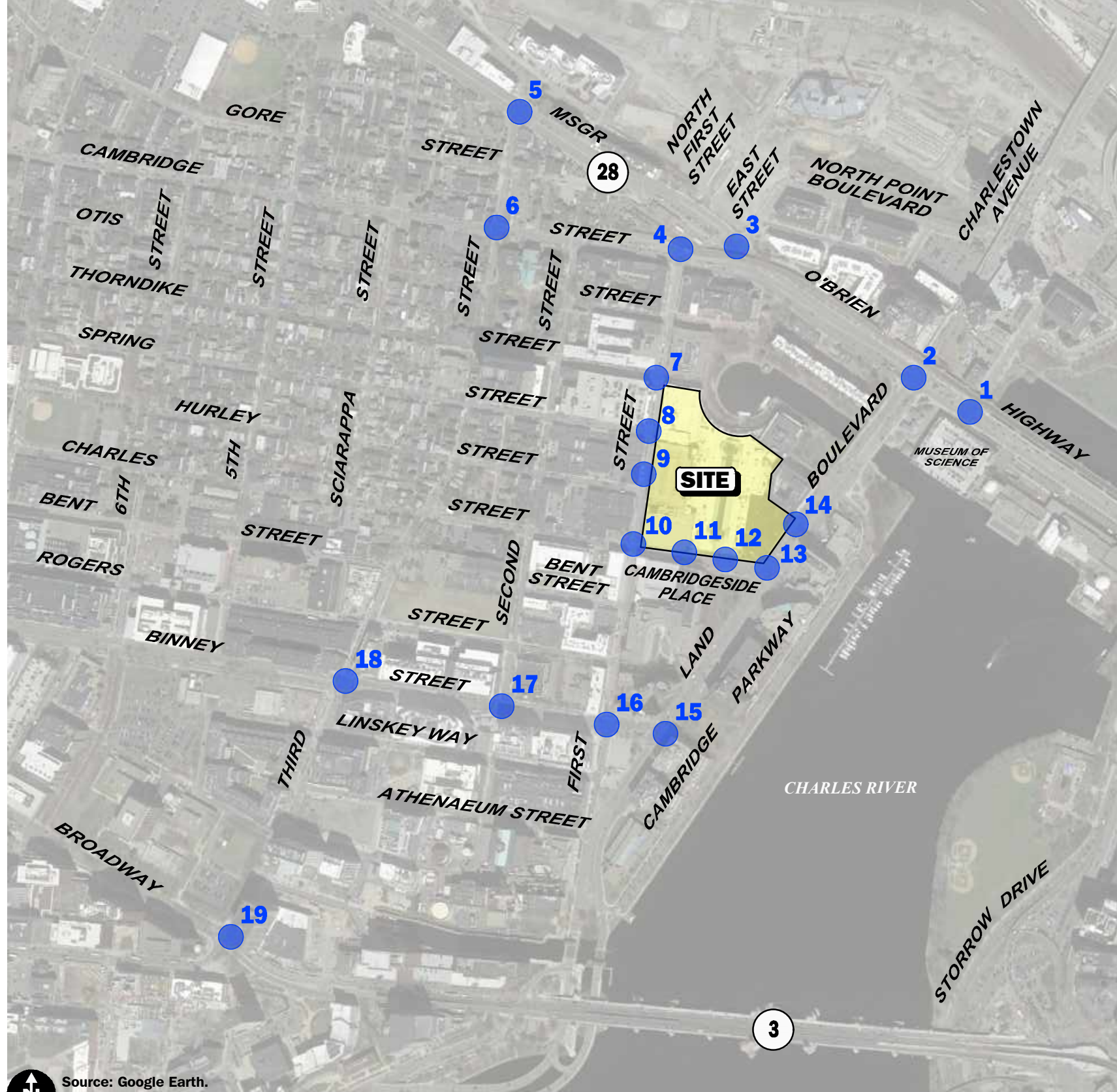


Figure 3.d.9
 Residential Trips
 Weekday Morning
 Peak Hour Traffic Volumes

R:\7810\Cambridgeside 2.0\7810\NT4.dwg, 7/9/2020 12:43:39 PM

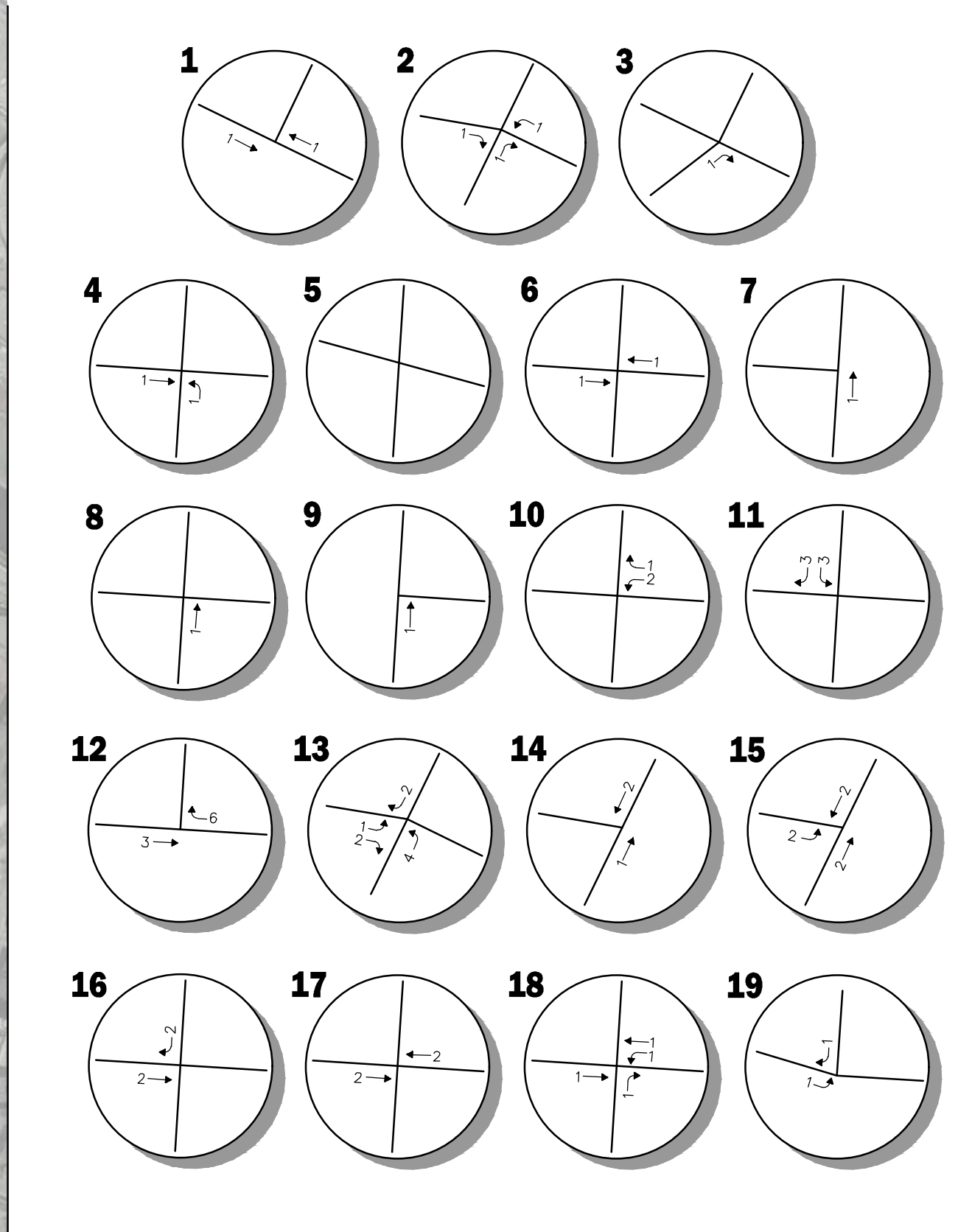
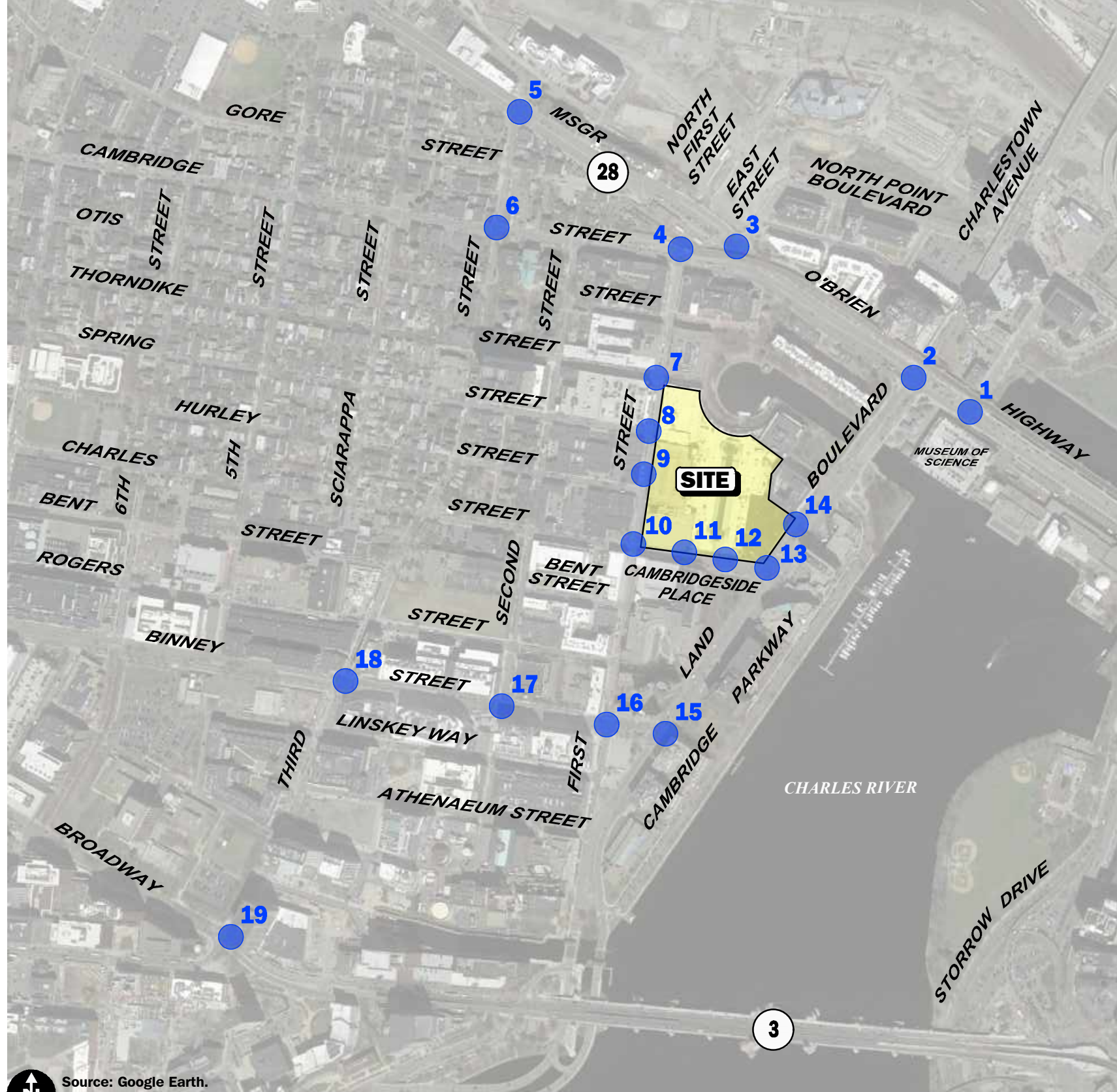


Figure 3.d.10
Residential Trips
Weekday Evening
Peak Hour Traffic Volumes

R:\17810\CambridgeSide 2.0\17810\NT4.dwg, 7/9/2020 12:45:59 PM

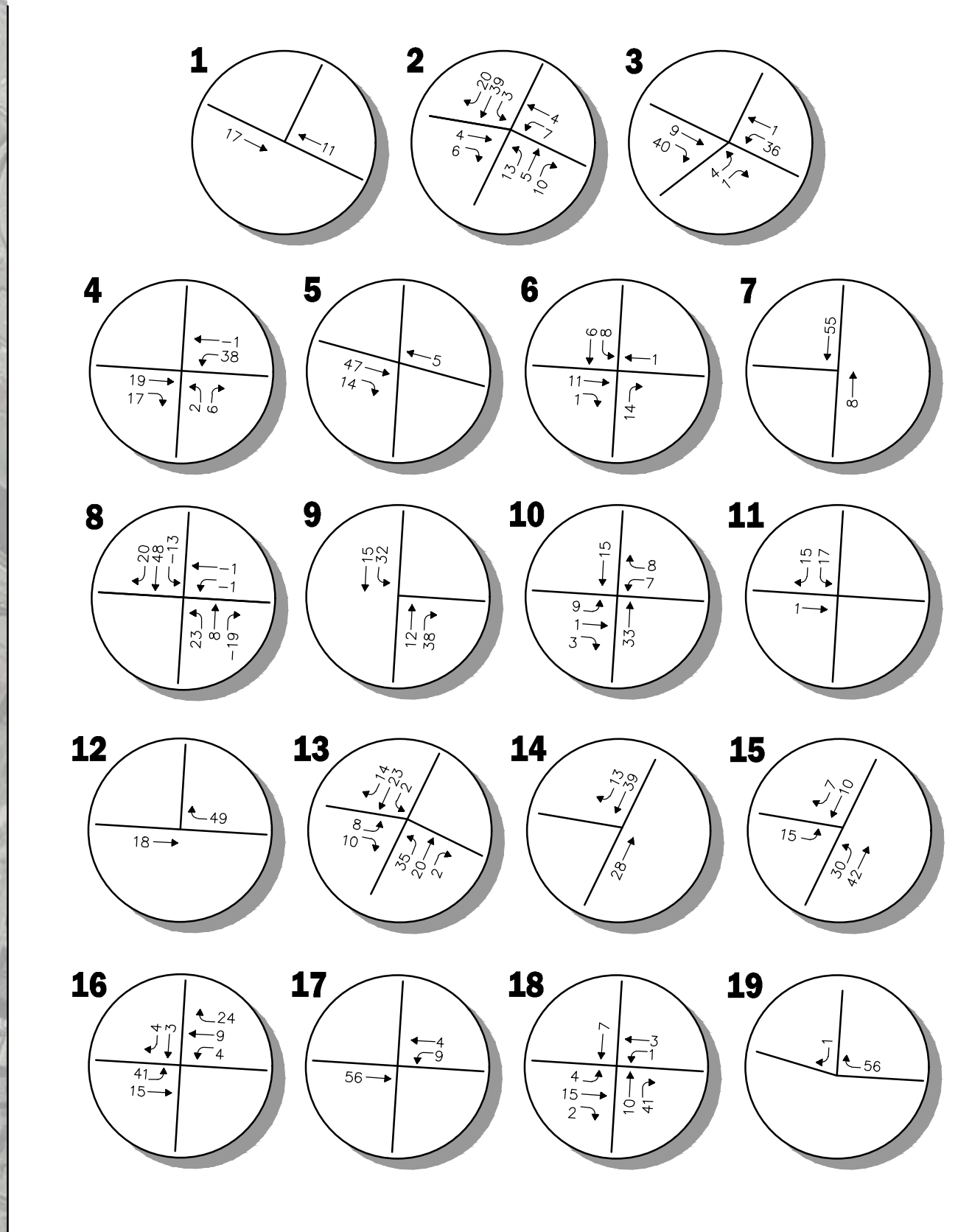
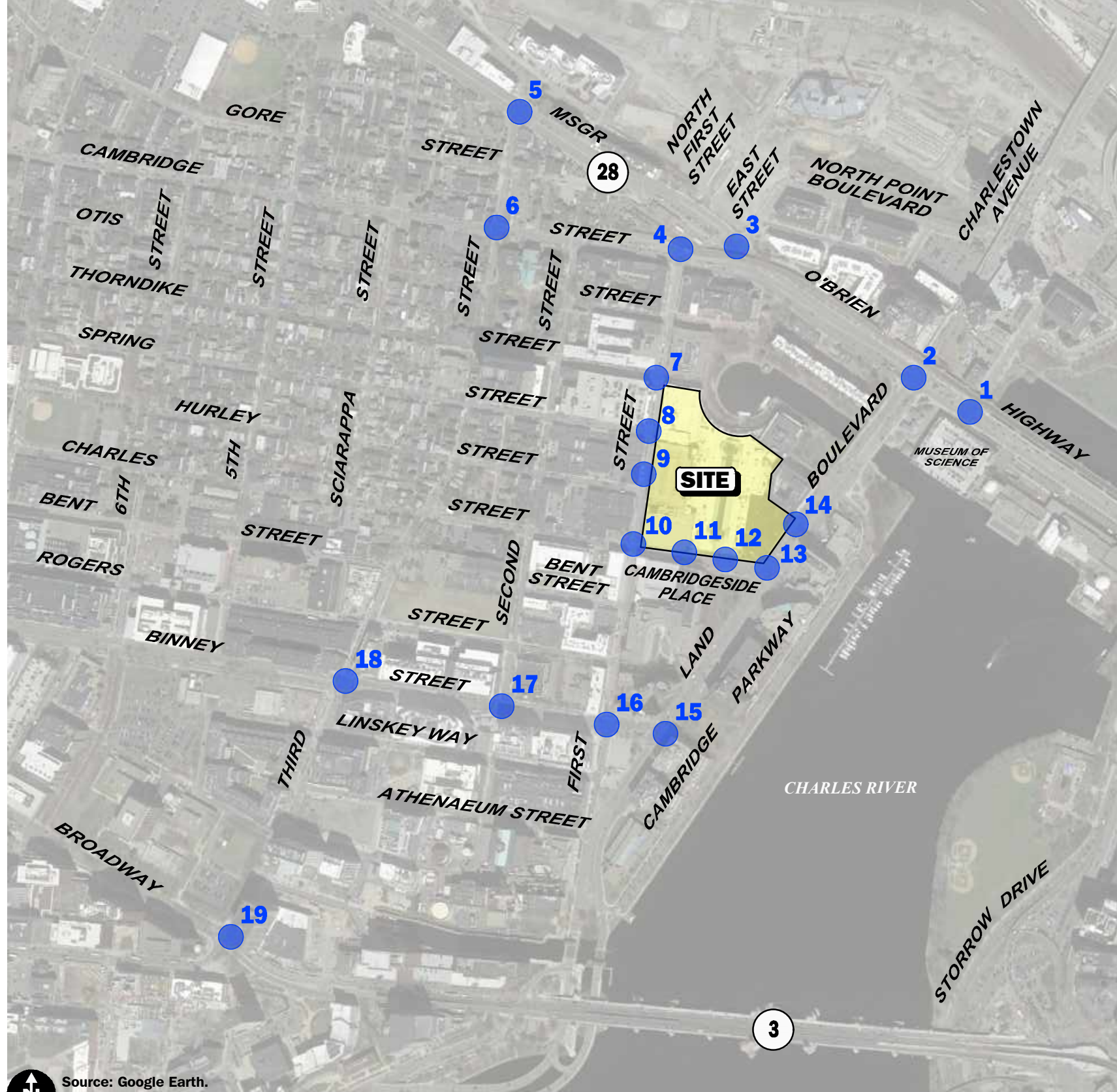


Figure 3.d.11
Net New Trips
Weekday Morning
Peak Hour Traffic Volumes

R:\7810\Cambridgeside 2.0\7810\NT4.dwg, 7/9/2020 12:46:50 PM

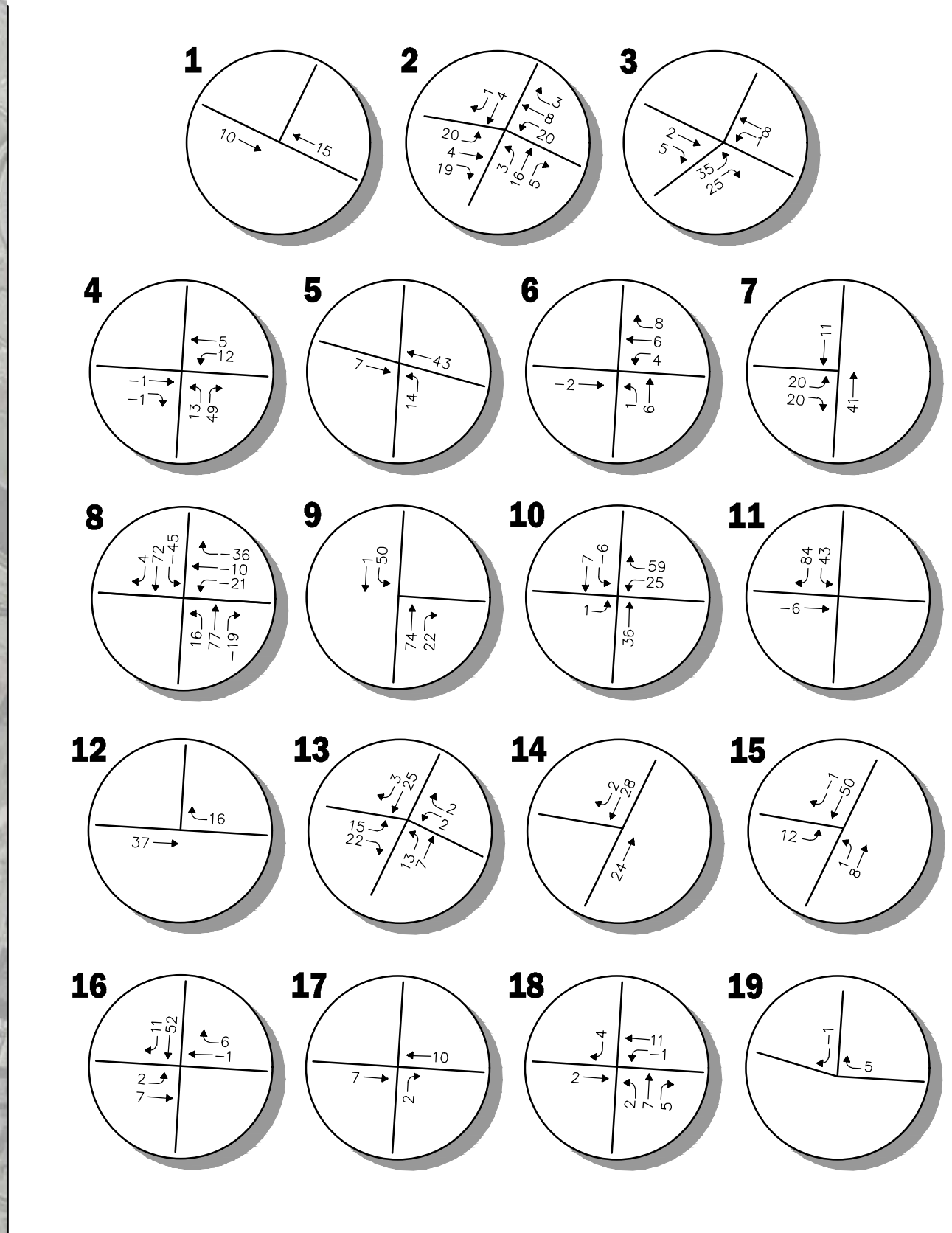
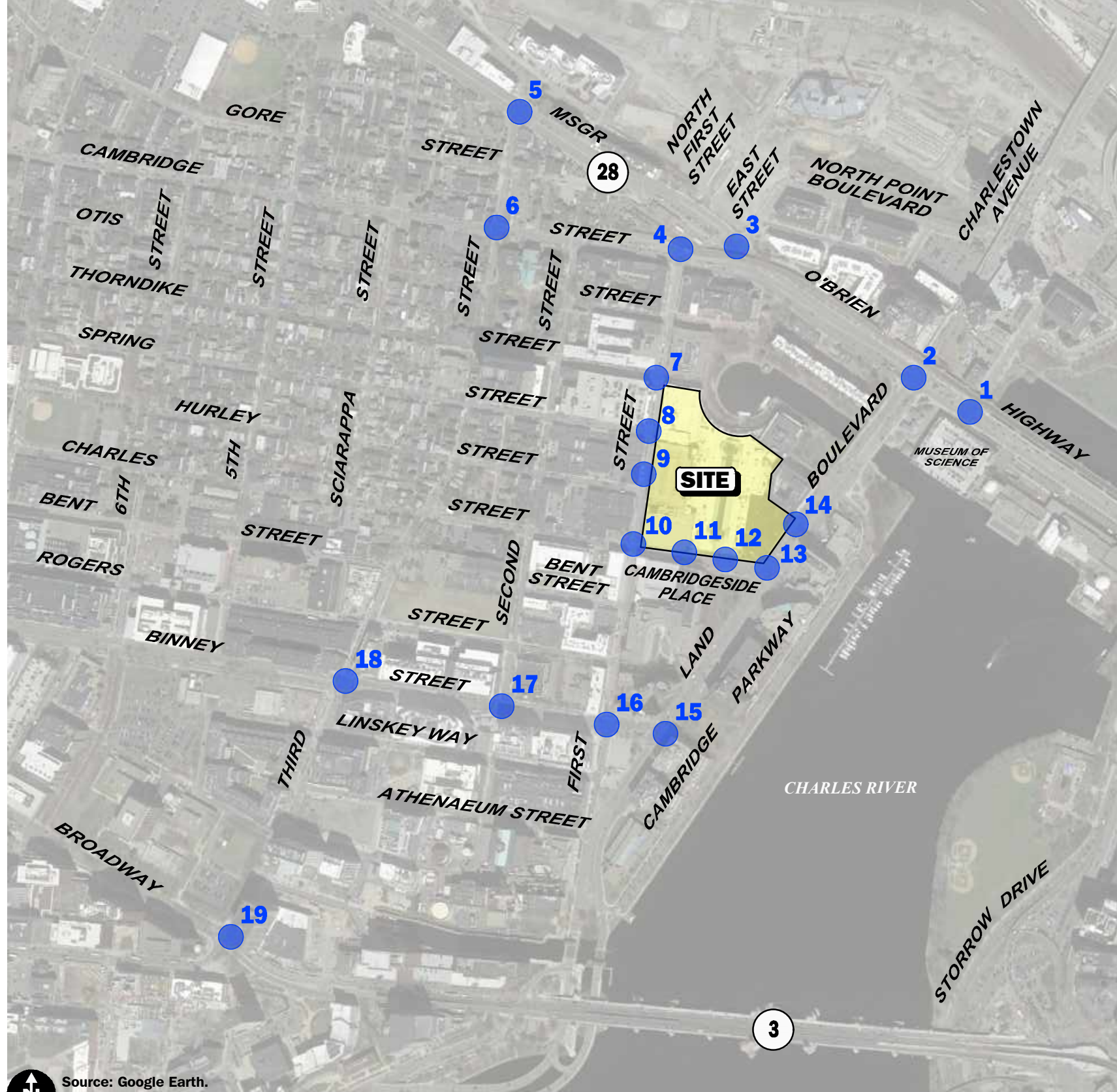


Figure 3.d.12
Net New Trips
Weekday Evening
Peak Hour Traffic Volumes

Source: Google Earth.
 0 275 550 Scale in Feet



CAMBRIDGESIDE PLACE

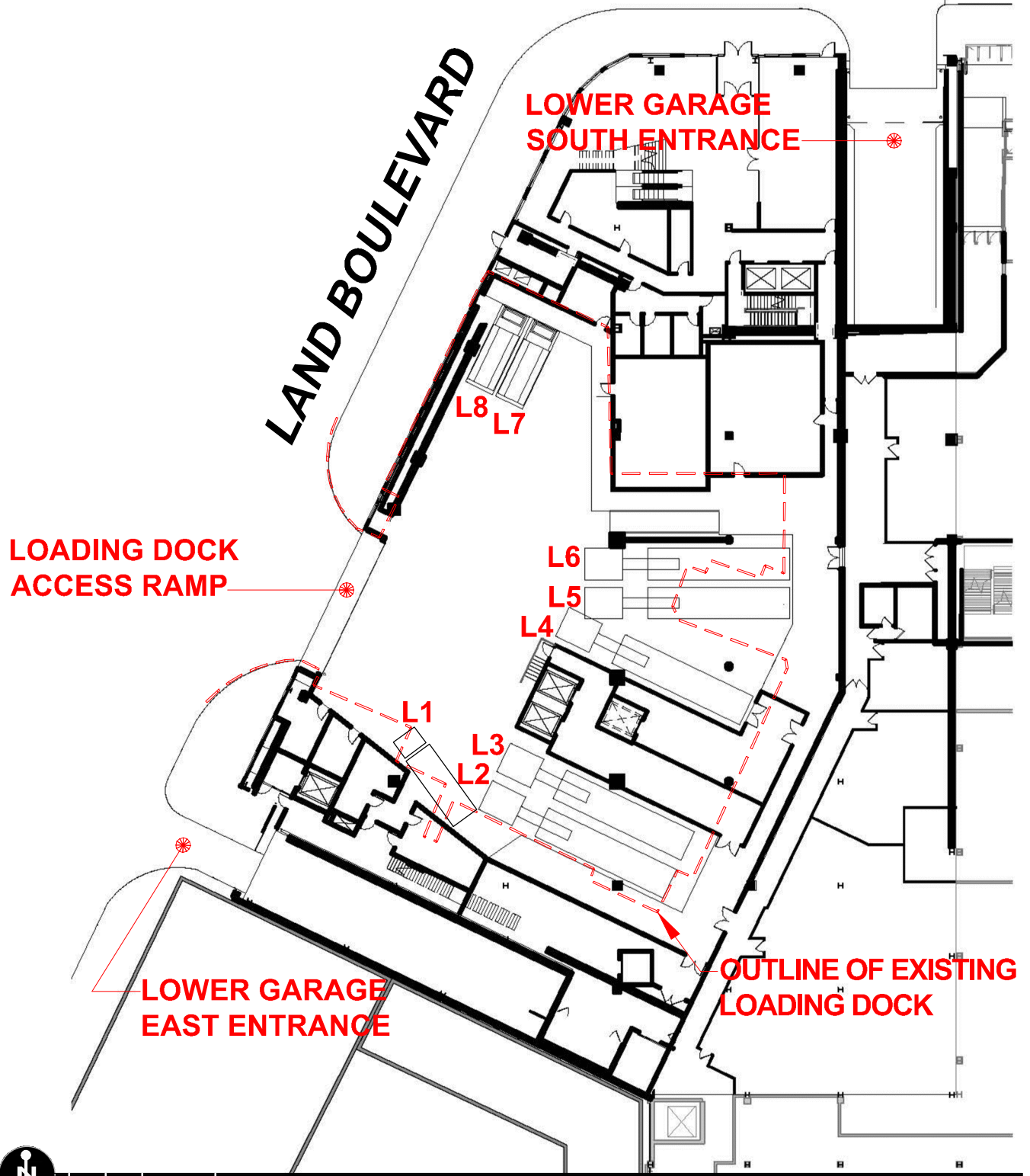
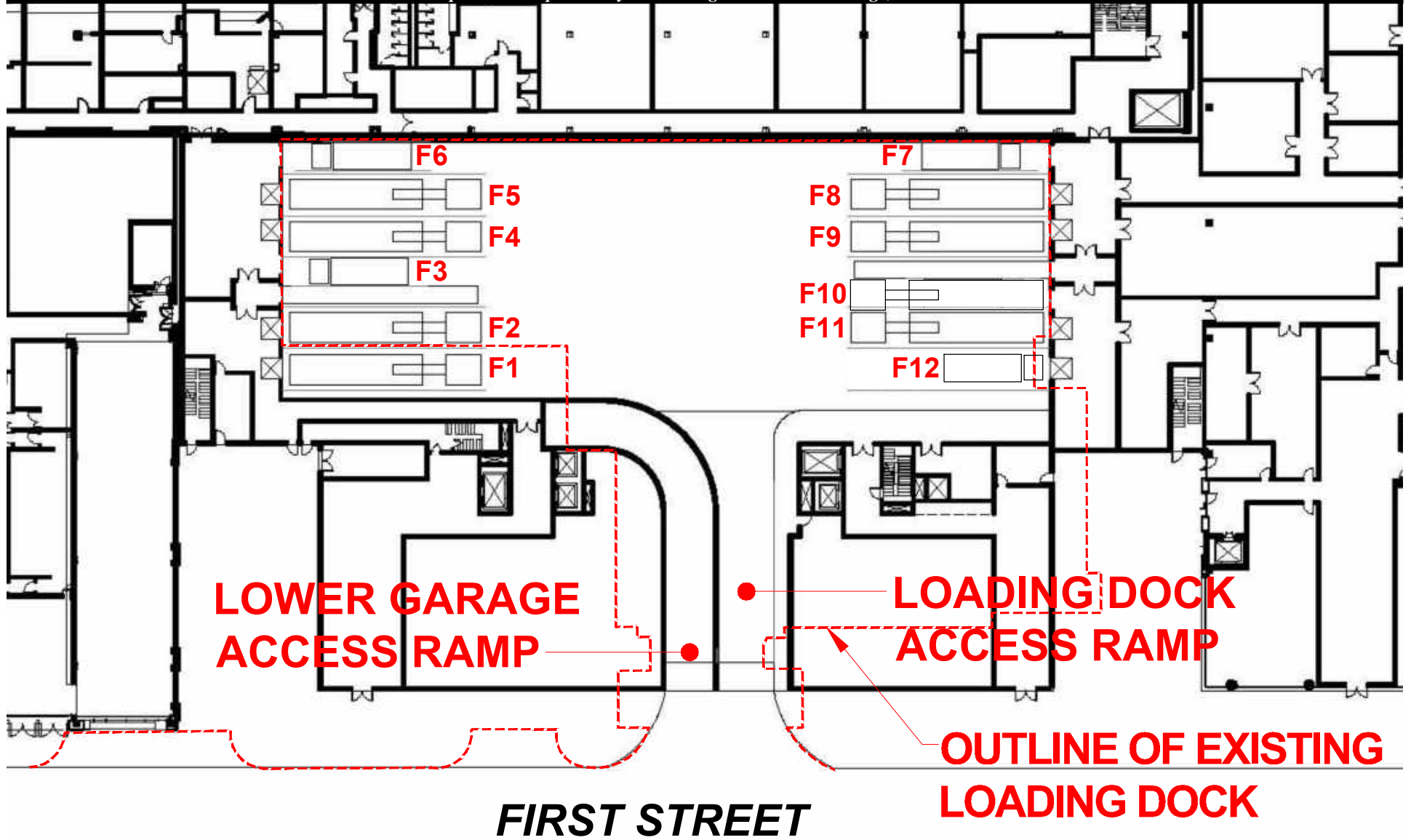


Figure 3.e.1

Revisions to Land Boulevard Loading Dock



R:\7810\Cambridgeside 2.0\7810loading.dwg, 7/21/2020 8:01:47 AM

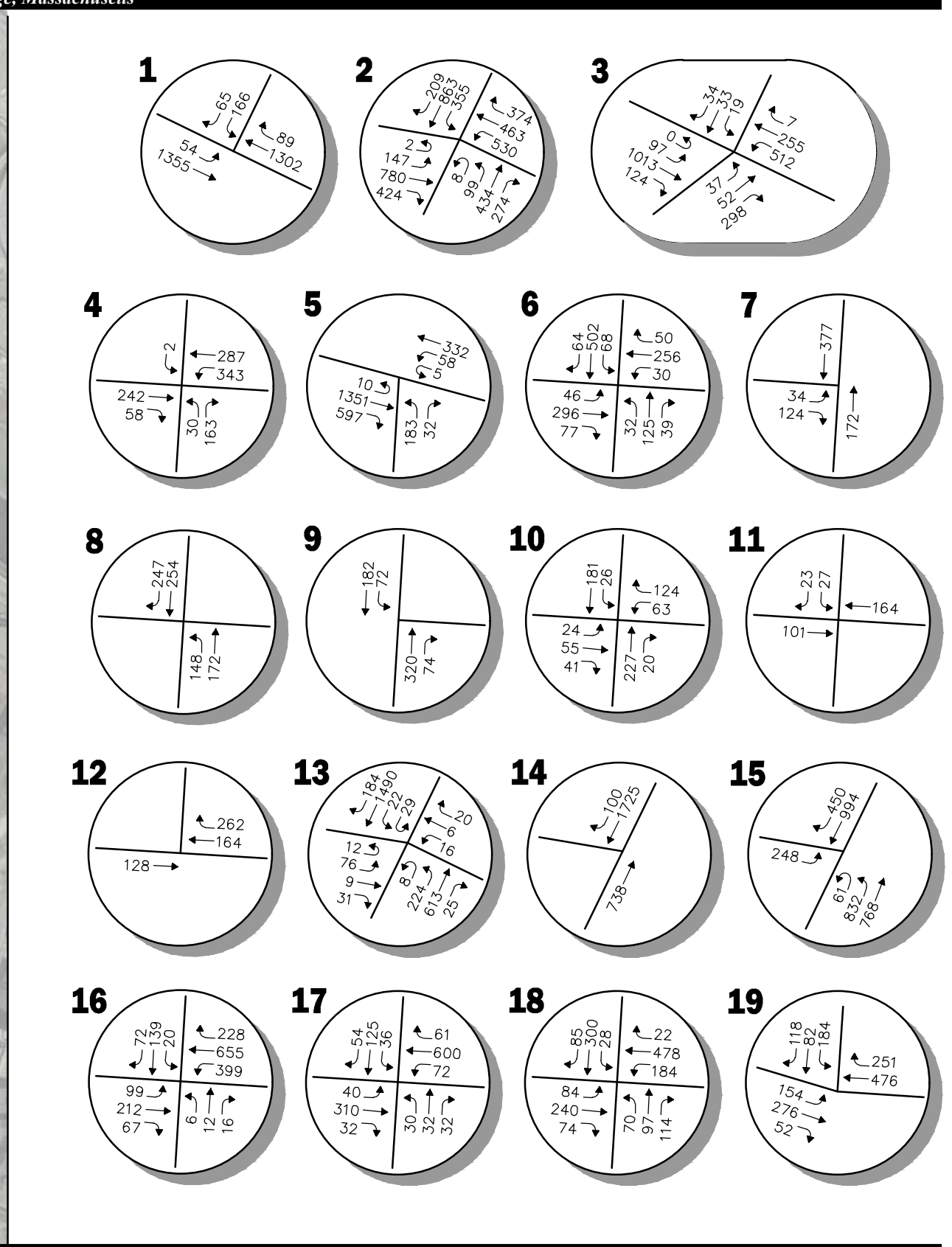


Source: Elkus Manfredi Architects.
0 20 40 Scale in Feet



Figure 3.e.2

Revisions to First Street Loading Dock

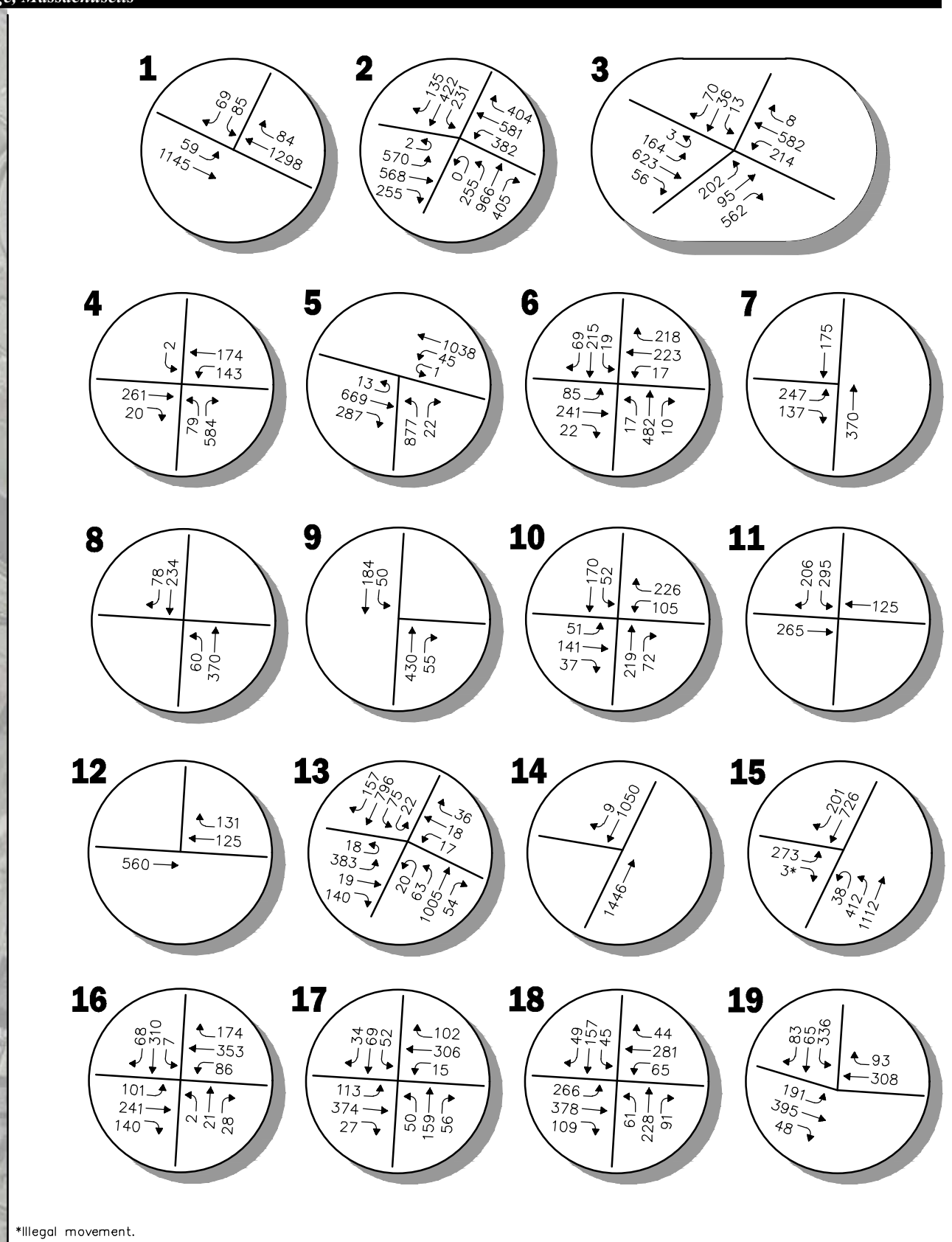


Source: Google Earth.
 0 275 550 Scale in Feet



Figure 5.b.1
 2020 Build
 Weekday Morning
 Peak Hour Traffic Volumes

R:\7810\Cambridgeside 2.0\7810\T3.dwg, 7/15/2020 12:55:48 PM



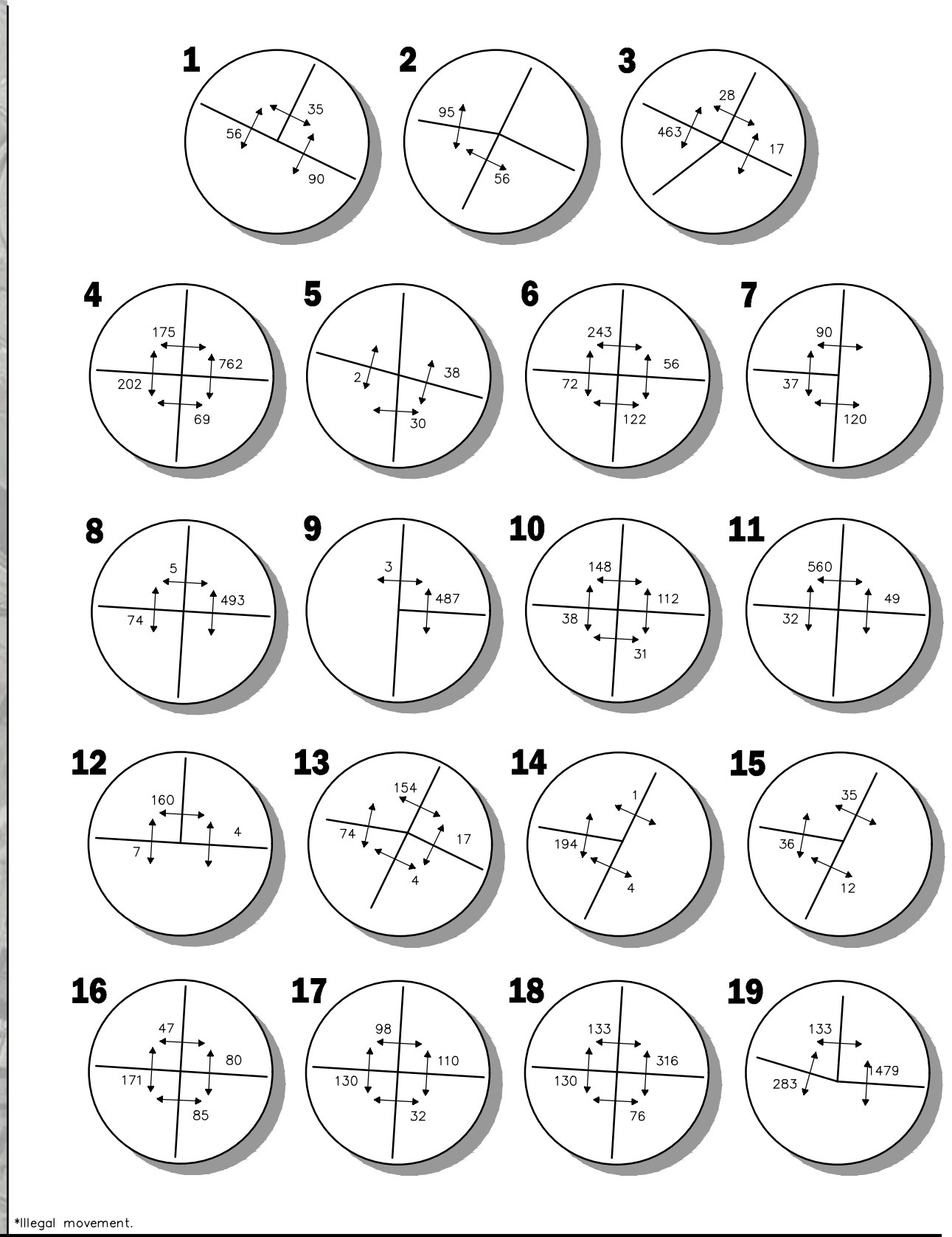
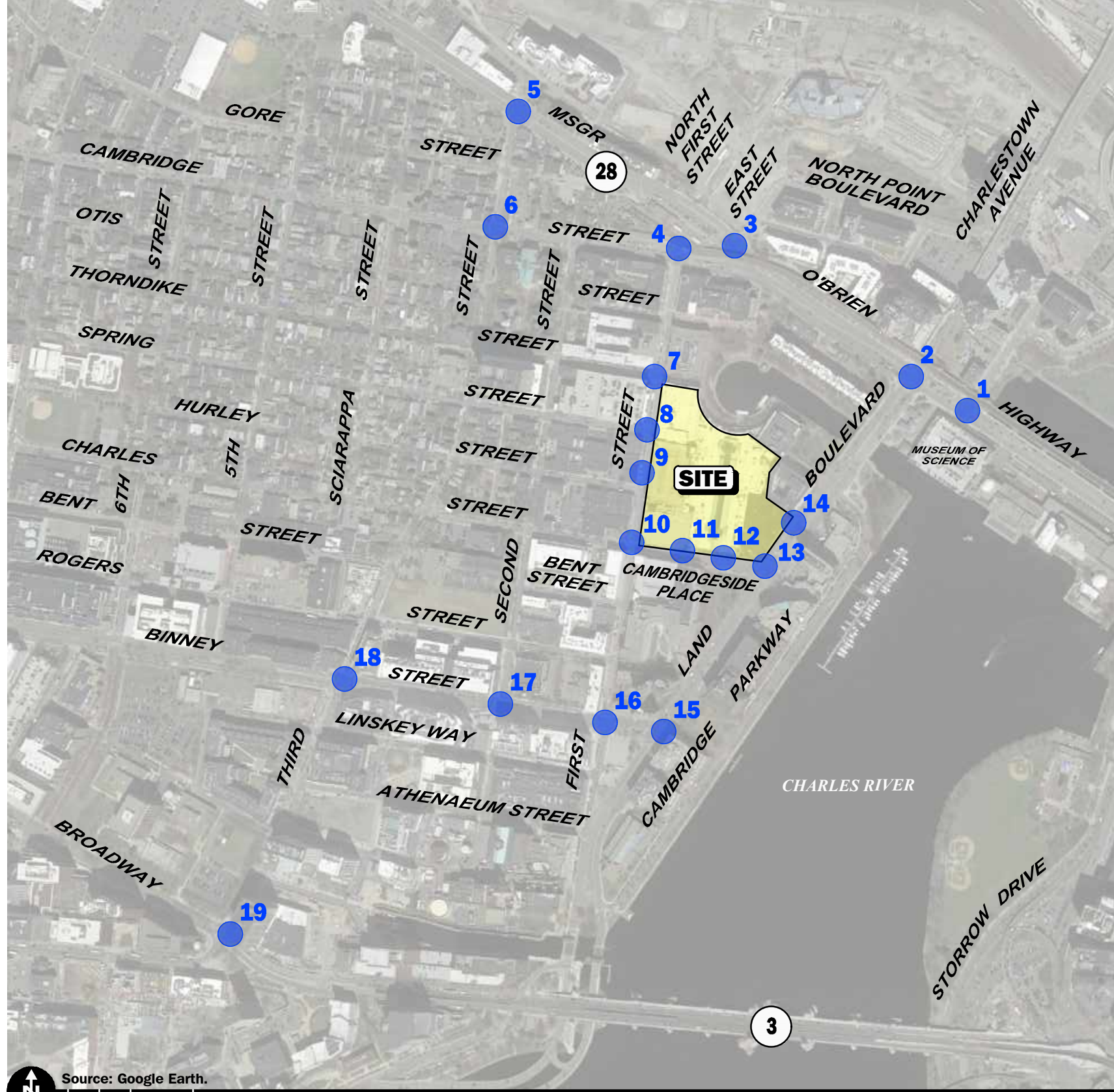
*Illegal movement.

Figure 5.b.2

2020 Build
Weekday Evening
Peak Hour Traffic Volumes

Source: Google Earth.
0 275 550 Scale in Feet





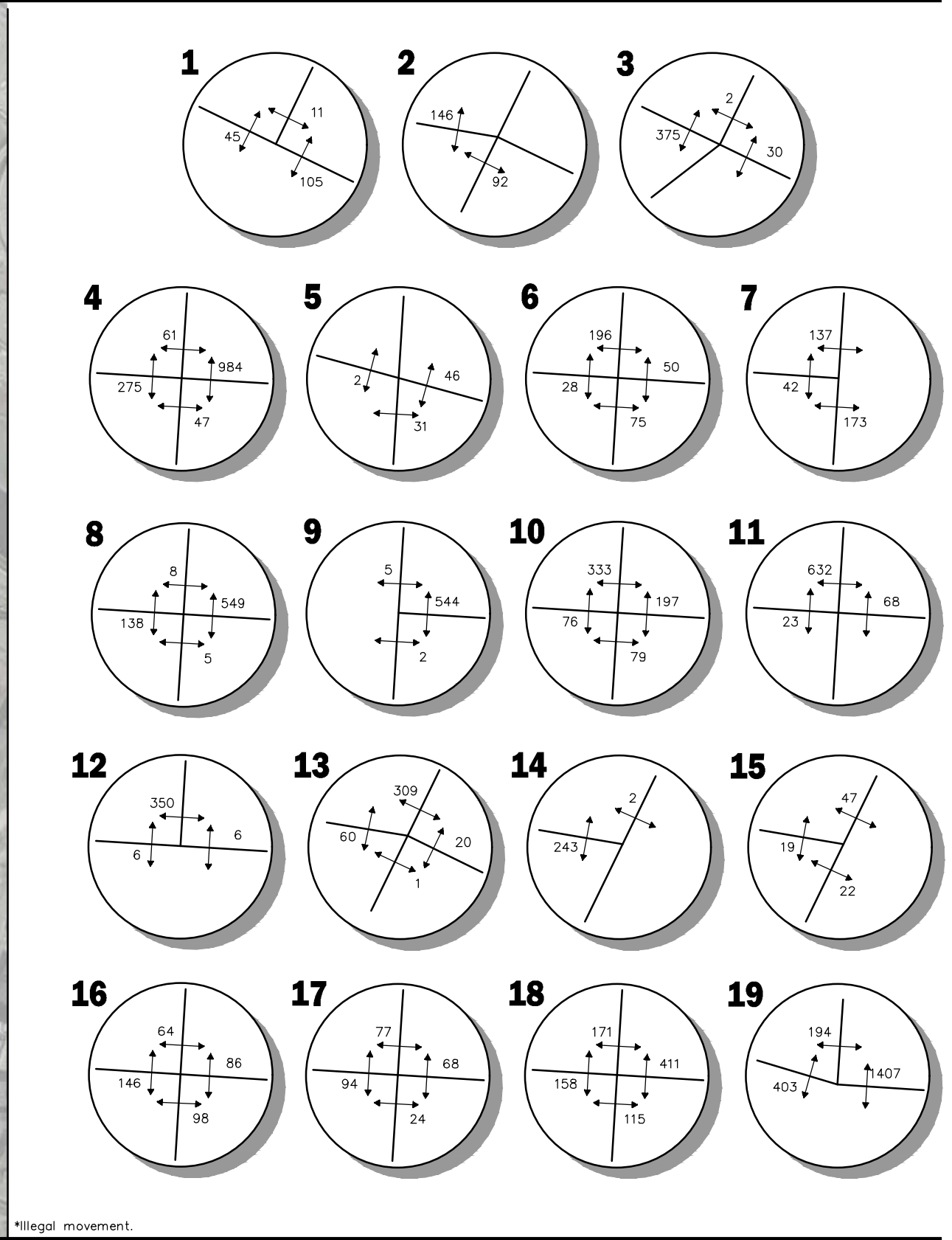
*Illegal movement.

Figure 5.b.3
 2020 Build
 Weekday Morning
 Peak Hour Pedestrian Volumes

R:\7810\Cambridgeside 2.0\7810\NT6.dwg, 7/9/2020 3:25:26 PM

Source: Google Earth.
 0 275 550 Scale in Feet





*Illegal movement.

Figure 5.b.4
 2020 Build
 Weekday Evening
 Peak Hour Pedestrian Volumes

R:\7810\Cambridgeside 2.0\7810\NT6.dwg, 7/19/2020 3:27:36 PM

Source: Google Earth.
 0 275 550 Scale in Feet



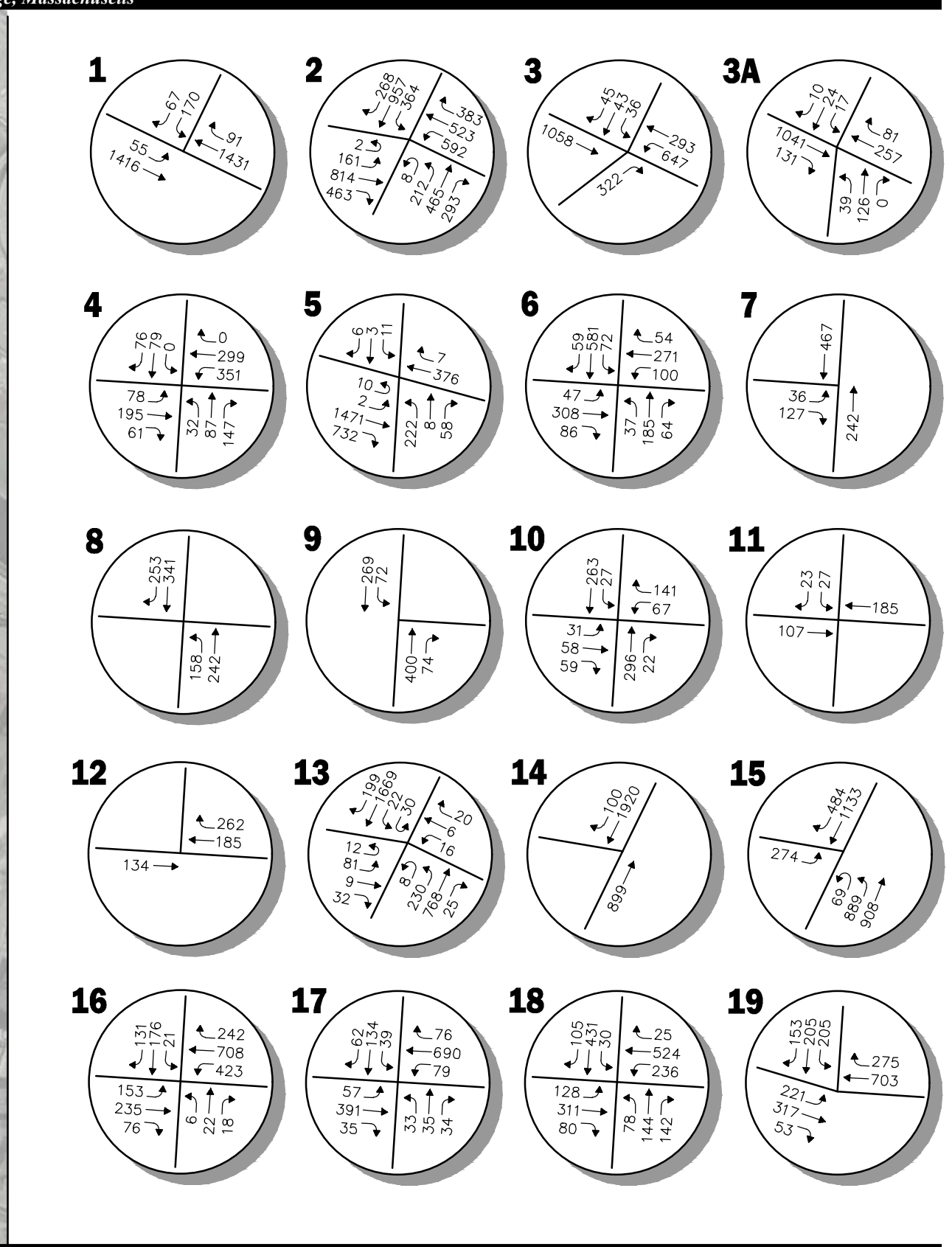


Figure 5.d.1
 2025 Future
 Weekday Morning
 Peak Hour Traffic Volumes

R:\7810\Cambridgeside 2.0\7810\T5.dwg, 7/19/2020 12:49:06 PM

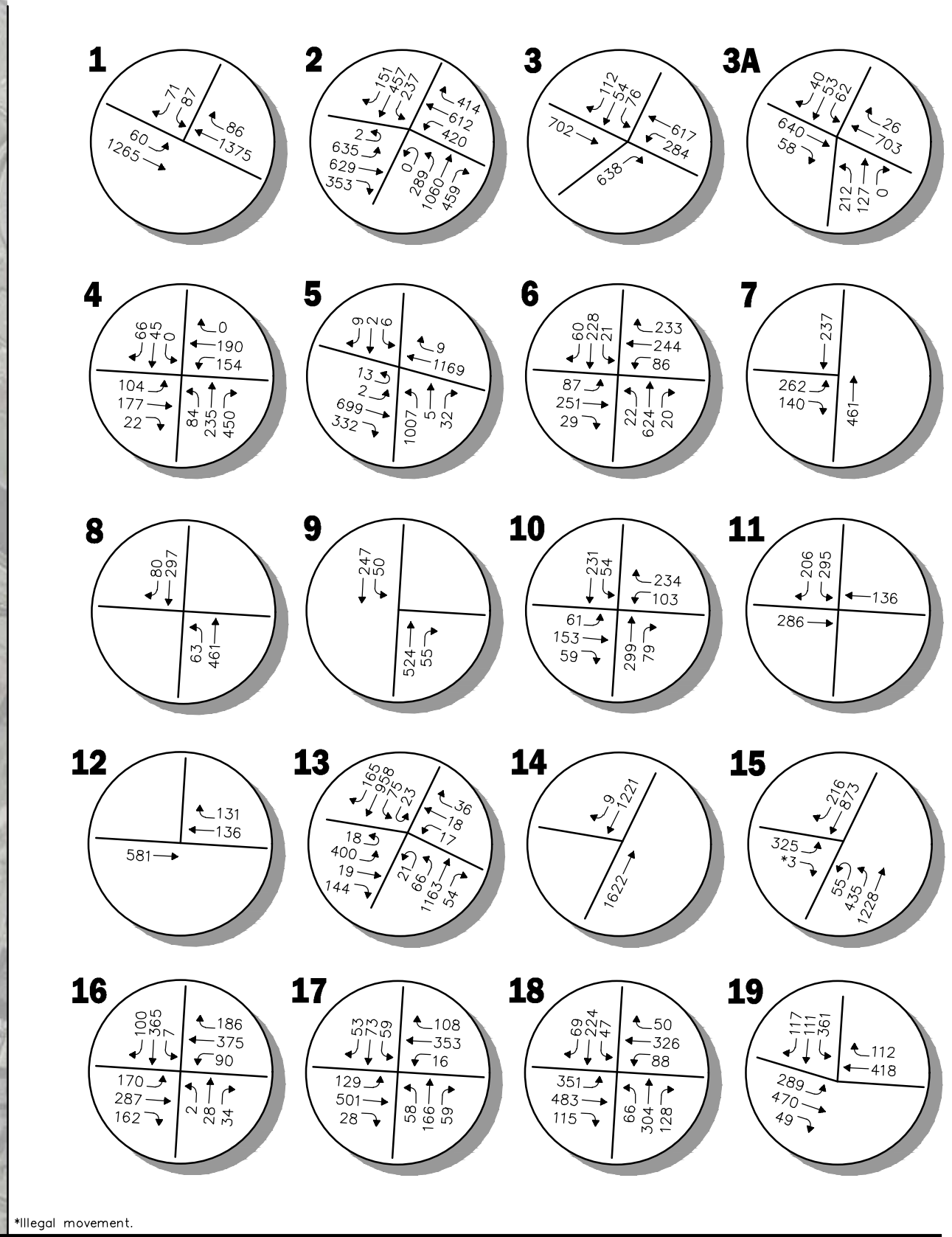
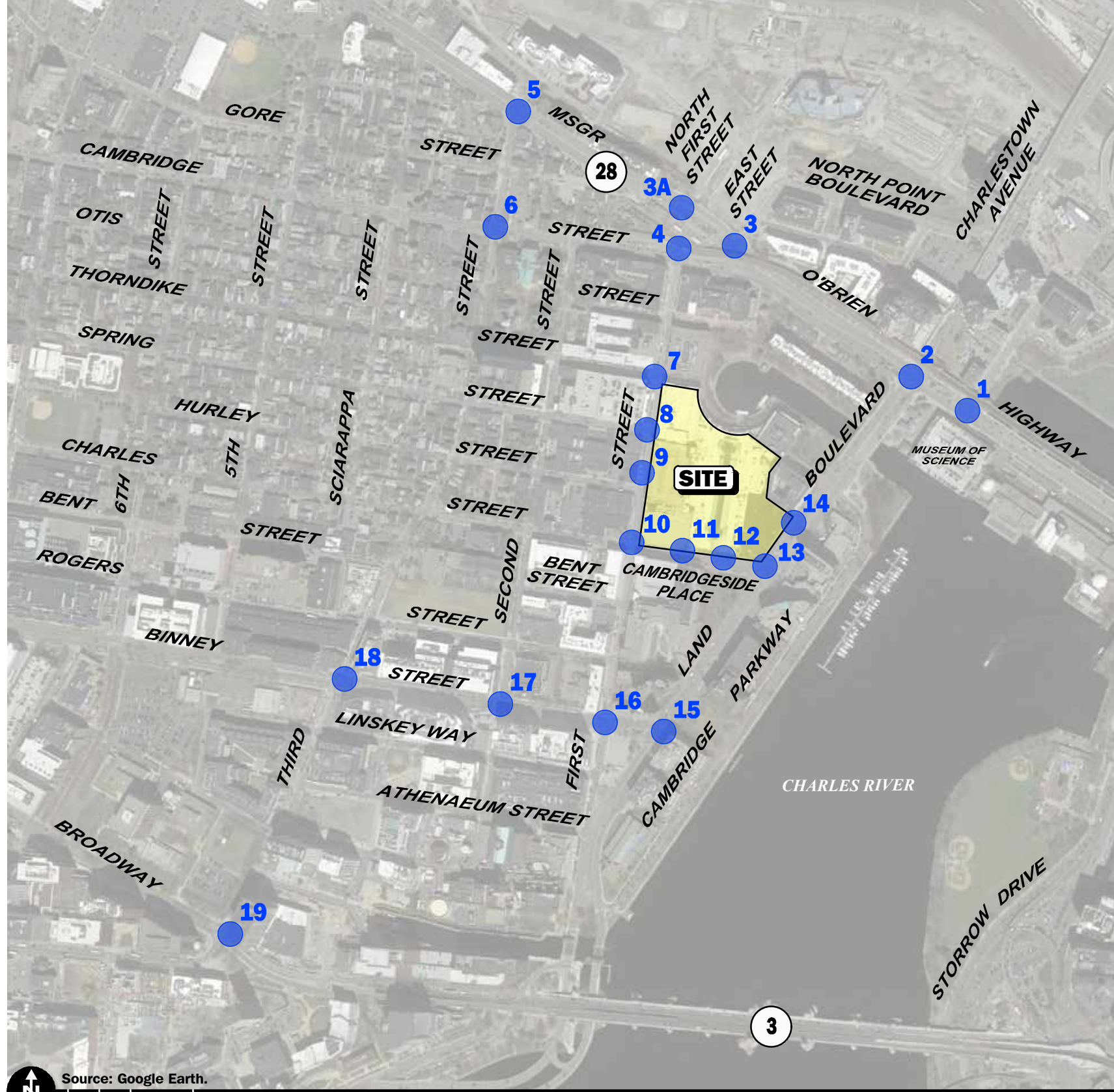


Figure 5.d.2
 2025 Future
 Weekday Evening
 Peak Hour Traffic Volumes

R:\7810\Cambridgeside 2.0\7810\NT5.dwg, 7/9/2020 12:51:12 PM

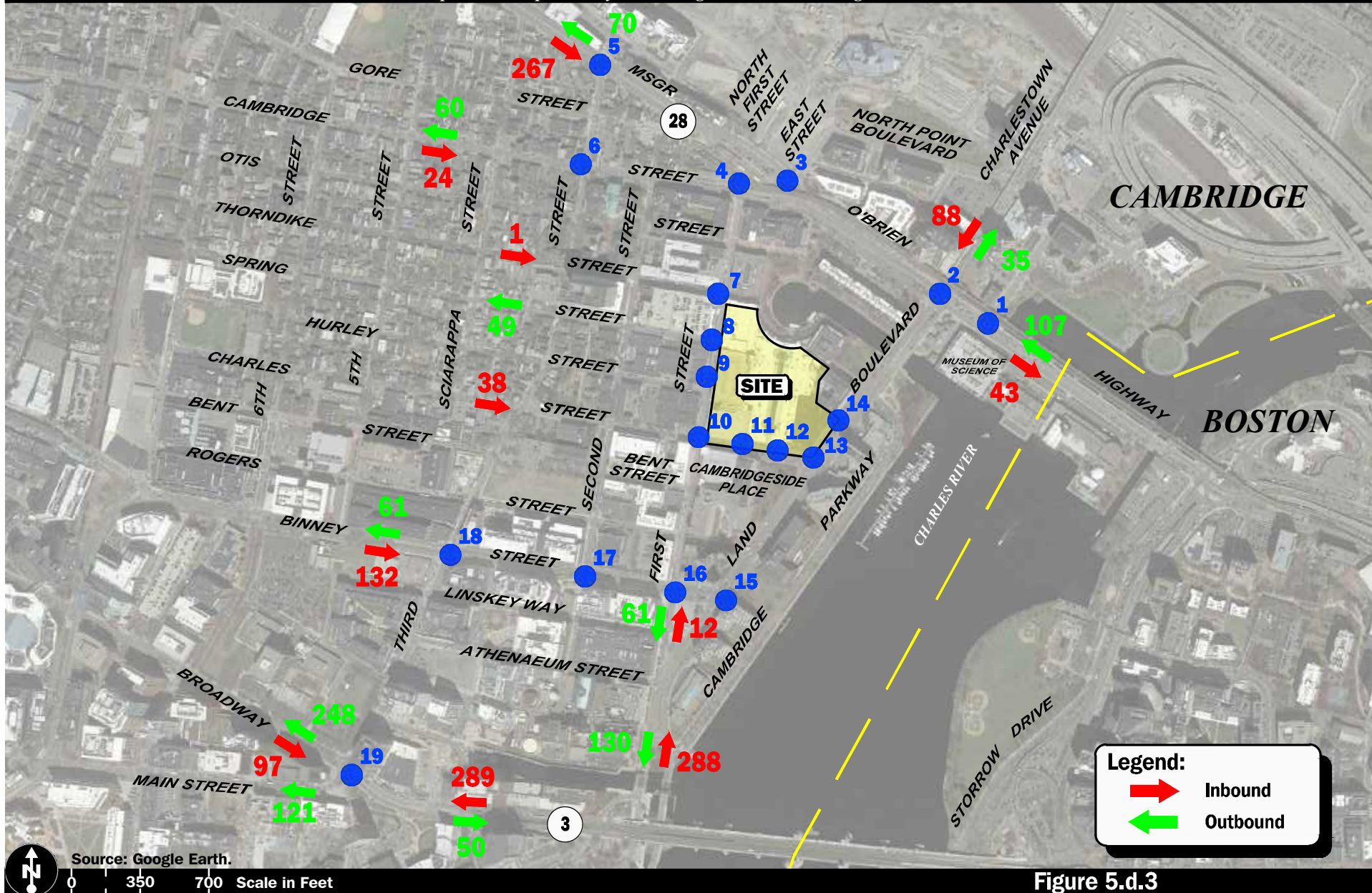


Figure 5.d.3
 Cumulative Area Developments Impact
 Weekday Morning
 Peak Hour Traffic Volumes

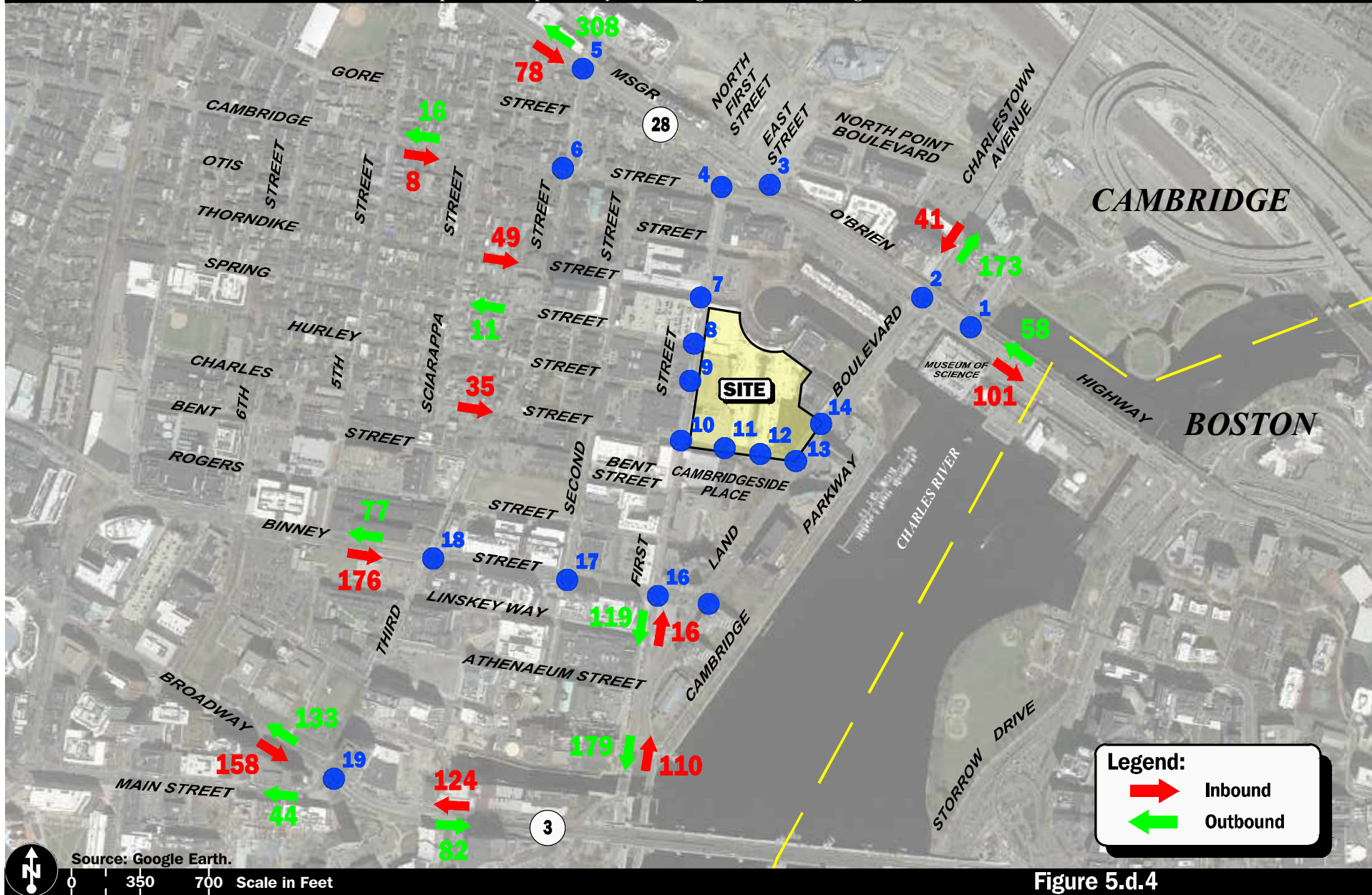
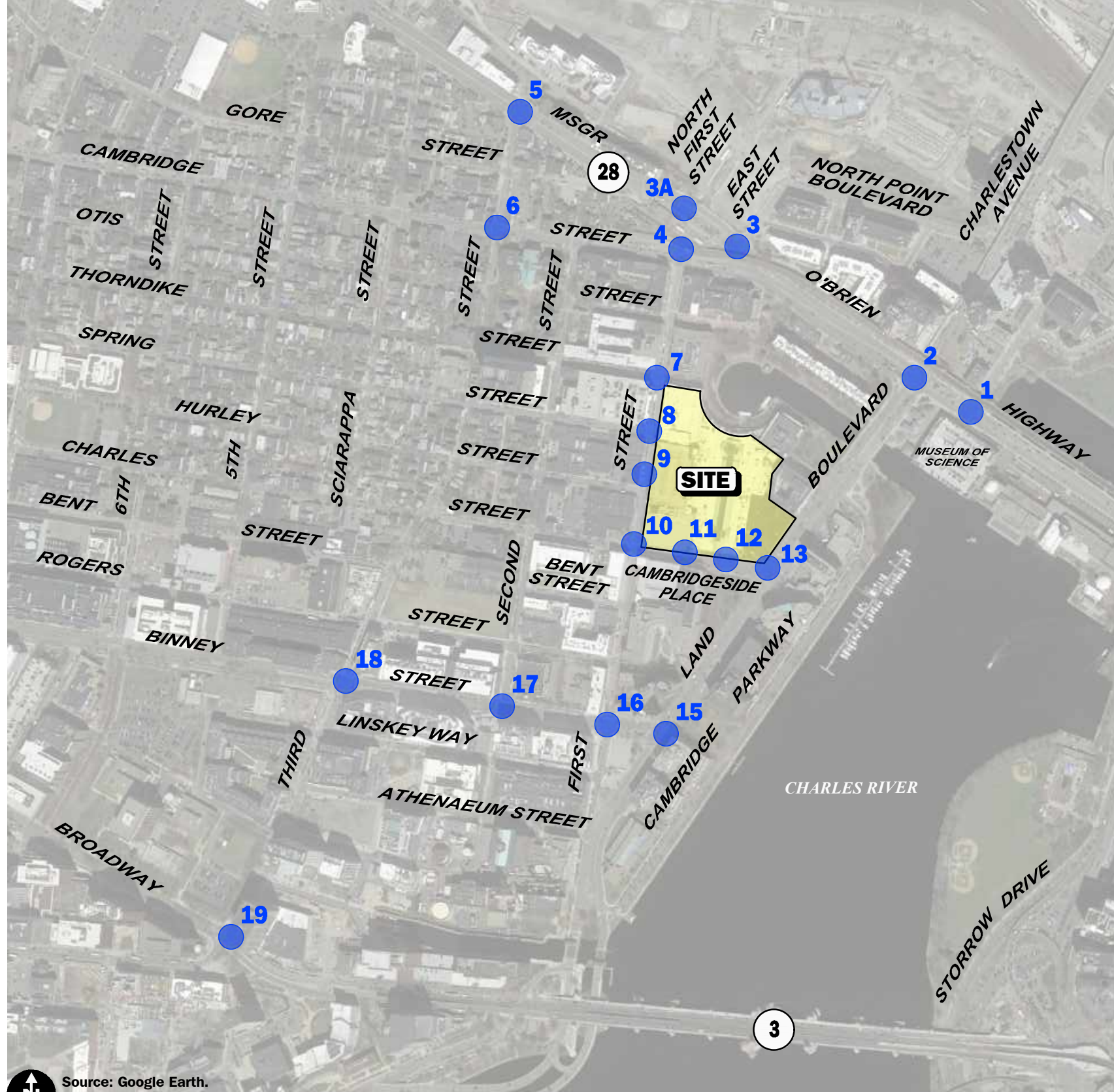


Figure 5.d.4
 Cumulative Area Developments Impact
 Weekday Evening
 Peak Hour Traffic Volumes



1 C C C C	2 F F F F	3 E F E C	3A - - - F	4 B B B C
5 E E E D	6 D C C E	7 A A A A	8* B B - -	9** A/A A/A A/A A/A
10 A B B B	11*** A/A A/A A/A A/A	12**** A/A A/A A/A A/A	13 B B D D	15 D D D E
16 B B B B	17 C C C C	18 C C C F	19 C C C E	

* Westbound Left / Through / Right Turn Movement
 ** Northbound Through / Right Turn Movement / Southbound Left Turn / Through Movement
 *** Southbound Left / Southbound Right Turn Movement
 **** Eastbound Through Movements / Westbound Through and Right Turn Movements
 All other intersections present Overall Level-of-Service

Legend:

X	2020 Existing
X	2020 Modified Existing
X	2020 Build
X	2025 Future

Figure 6.a.1
 Vehicle Level-of-Service Map
 Weekday Morning Peak Hour

Source: Google Earth.
 0 275 550 Scale in Feet



R:\7810\Cambridgeside 2.0\7810NT7.dwg, 7/15/2020 1:17:05 PM

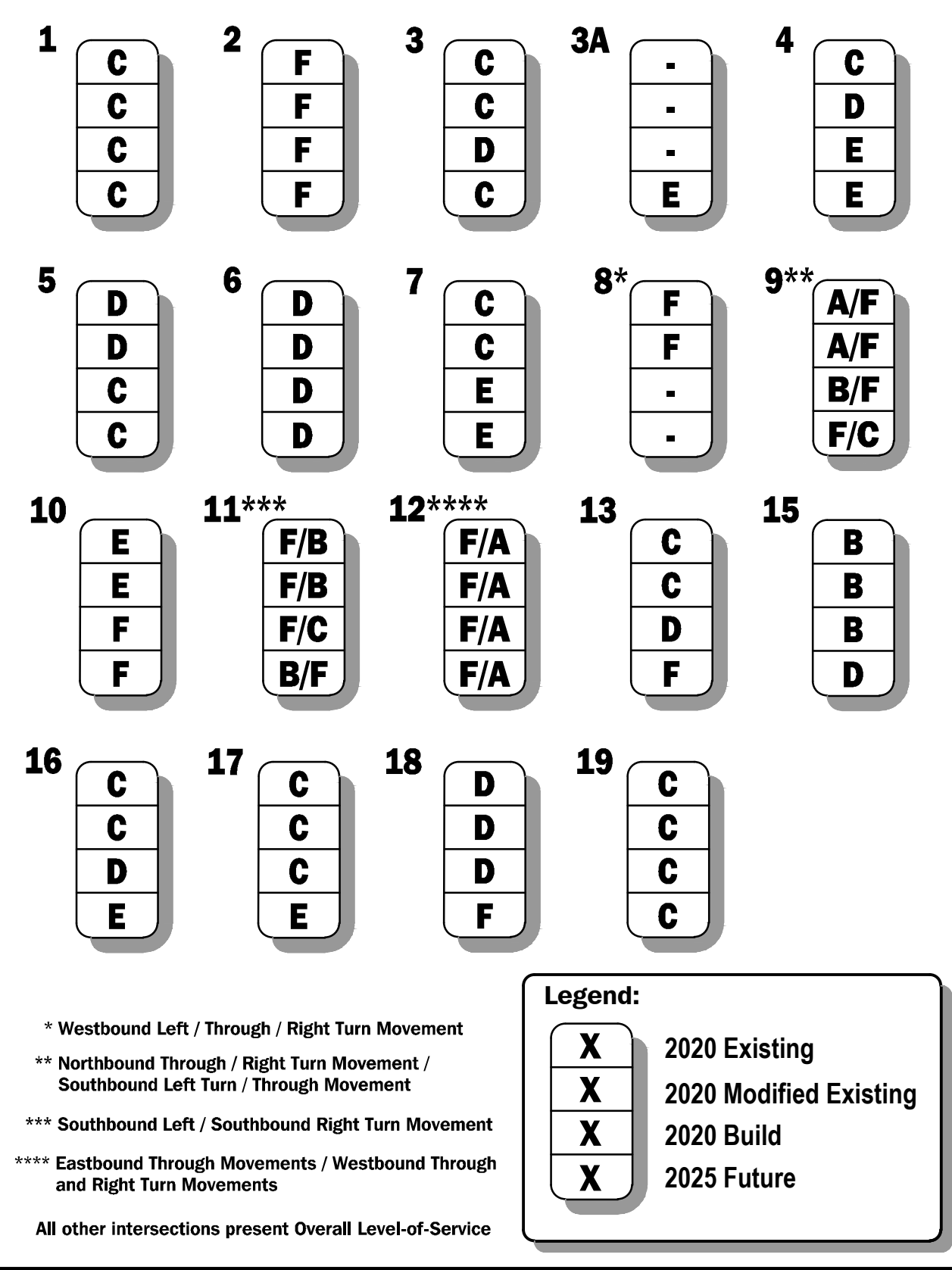
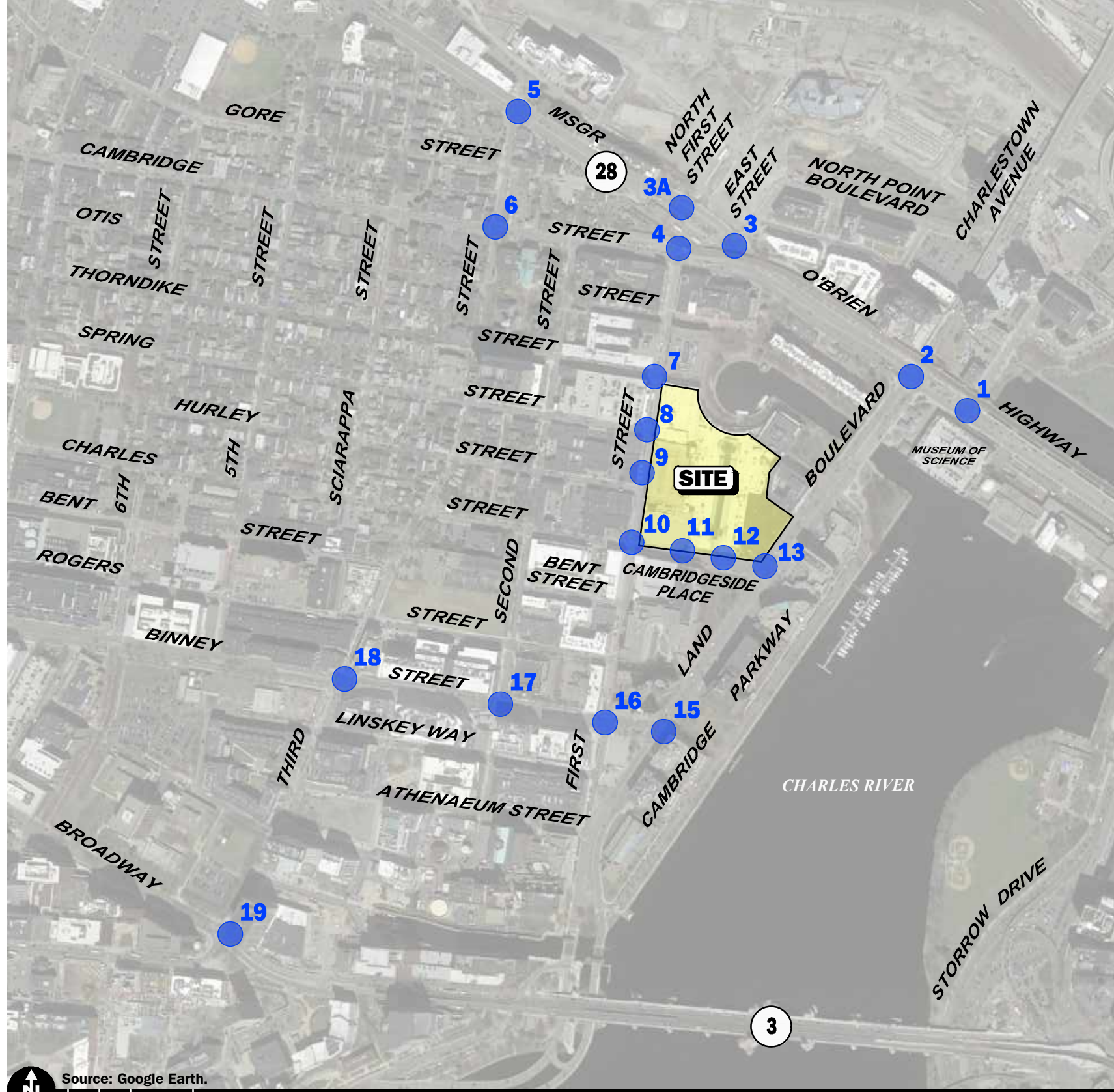
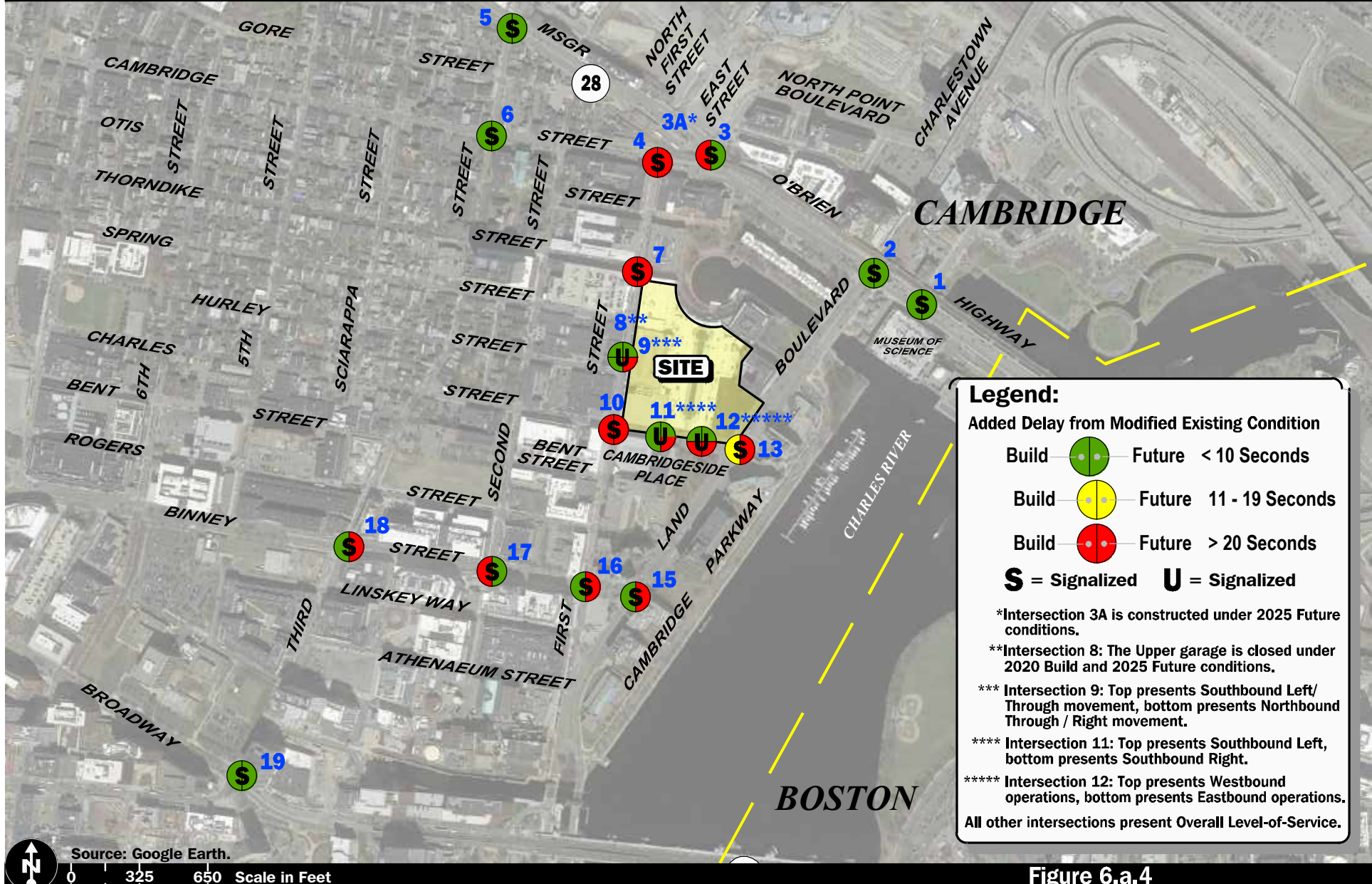


Figure 6.a.2

Vehicle Level-of-Service Map
Weekday Evening Peak Hour

Source: Google Earth.
0 275 550 Scale in Feet





Legend:

Added Delay from Modified Existing Condition

Build Future < 10 Seconds

Build Future 11 - 19 Seconds

Build Future > 20 Seconds

S = Signalized **U** = Signalized

*Intersection 3A is constructed under 2025 Future conditions.

**Intersection 8: The Upper garage is closed under 2020 Build and 2025 Future conditions.

*** Intersection 9: Top presents Southbound Left/Through movement, bottom presents Northbound Through / Right movement.

**** Intersection 11: Top presents Southbound Left, bottom presents Southbound Right.

***** Intersection 12: Top presents Westbound operations, bottom presents Eastbound operations.

All other intersections present Overall Level-of-Service.

Figure 6.a.4
Vehicle Delay Change Map
Weekday Evening Peak Hour

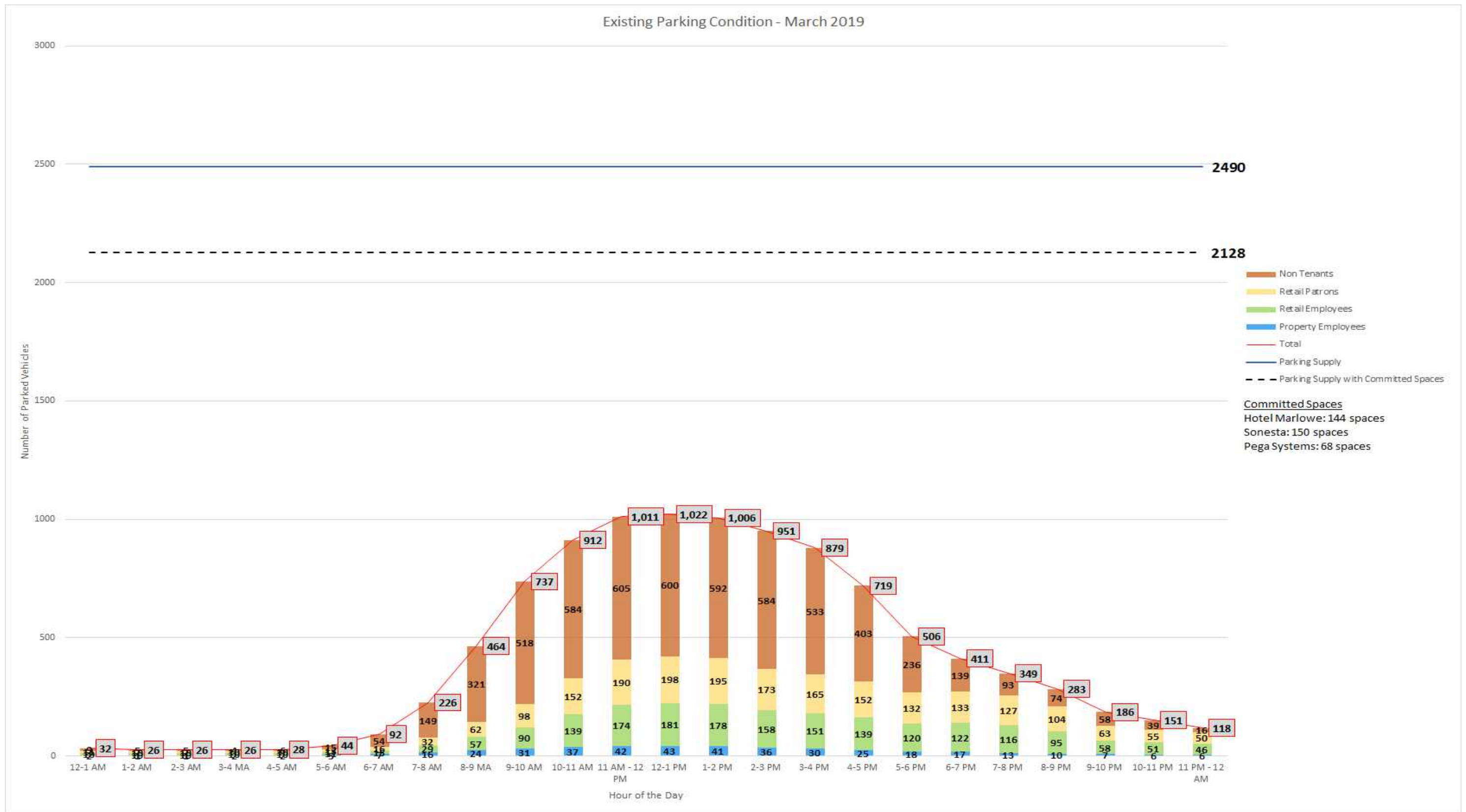


Figure 9.a.1
 Existing CambridgeSide
 Parking Condition - March



R:\7810\Cambridgeside 2.0\7810CHRT.dwg, 5/13/2020 12:48:49 PM

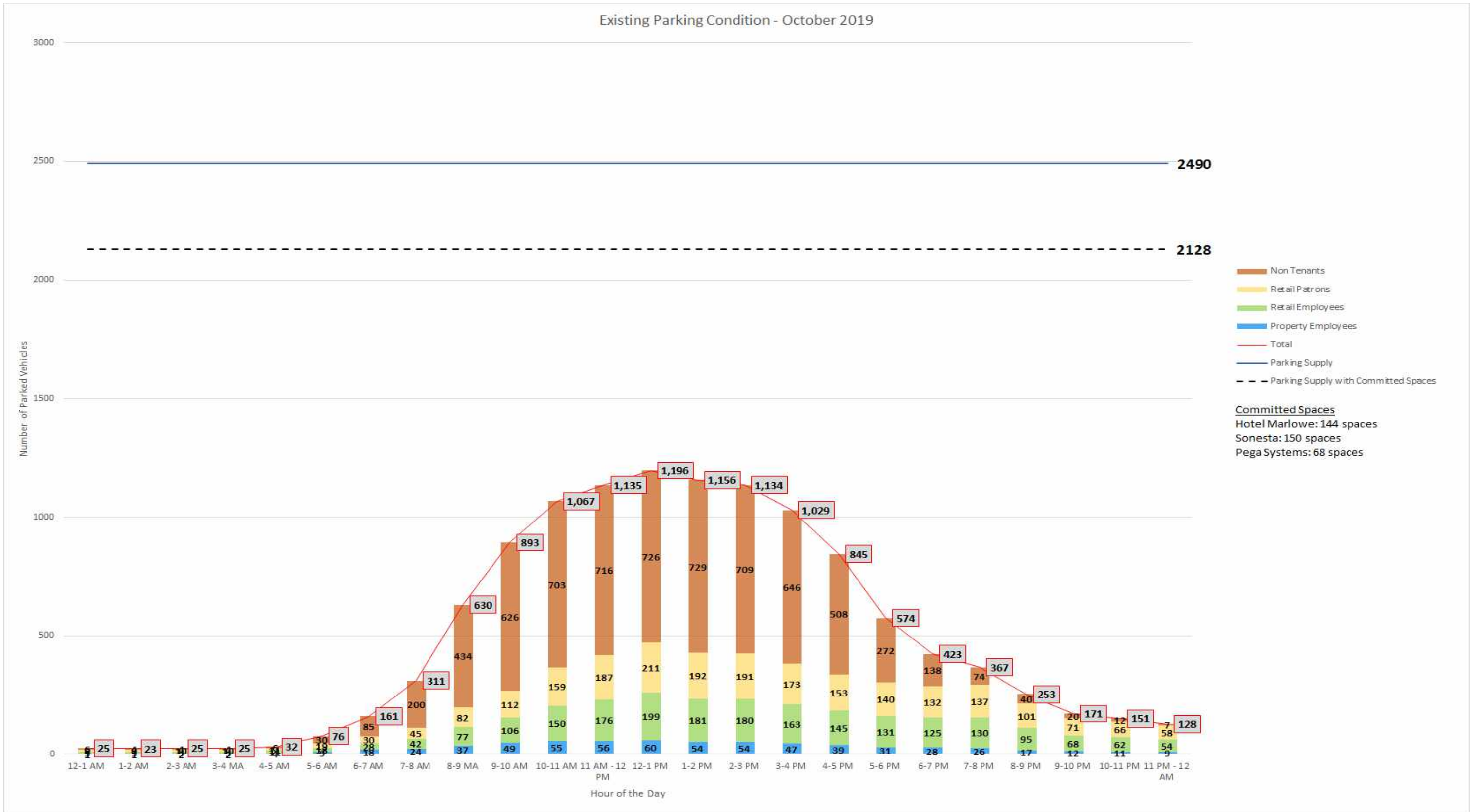


Figure 9.a.2

Existing CambridgeSide
 Parking Condition - October

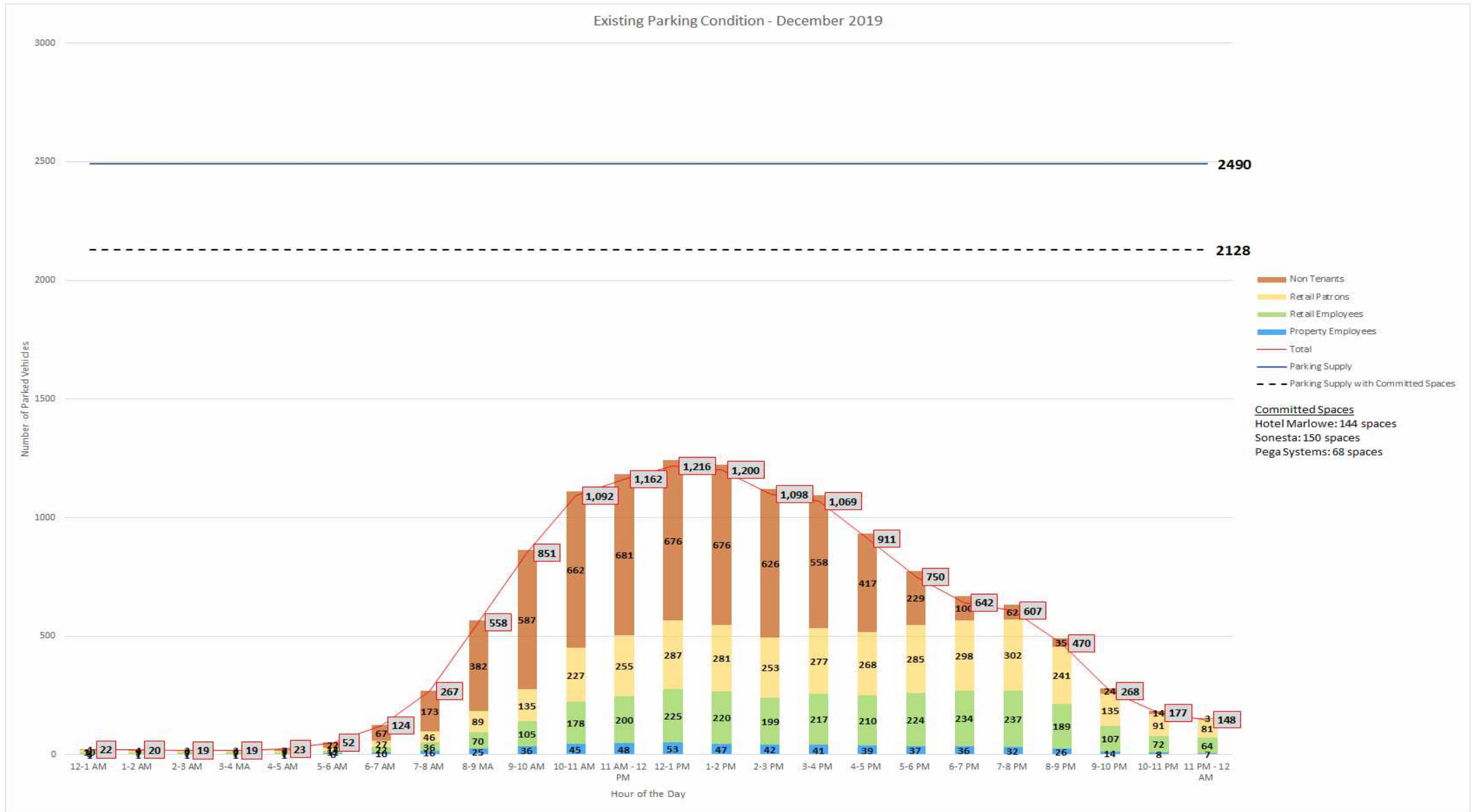


Figure 9.a.3
 Existing CambridgeSide
 Parking Condition - December



R:\7810\Cambridgeside 2.0\7810CHRT.dwg, 5/13/2020 12:11:21 PM

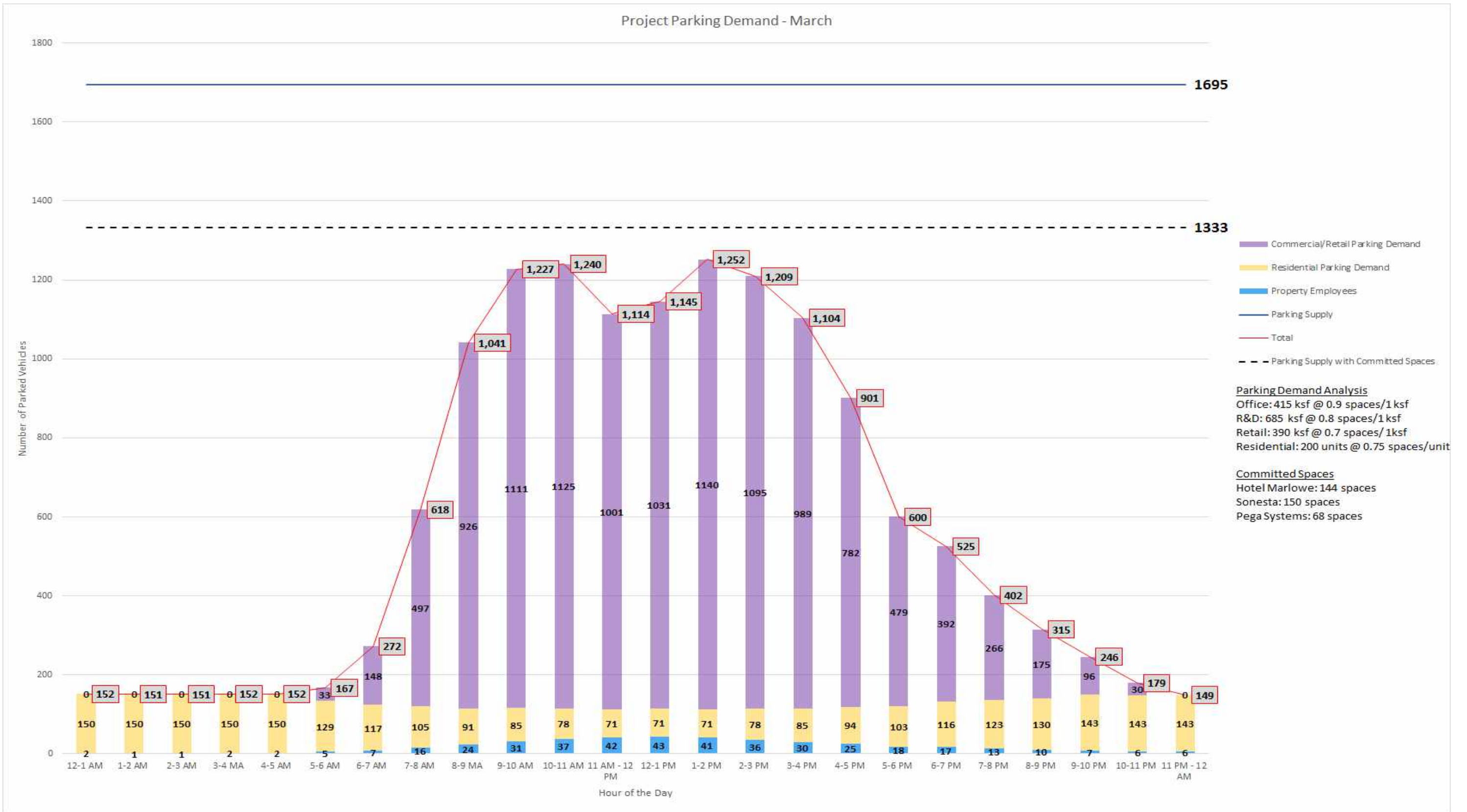


Figure 9.c.1
 Future Project
 Parking Condition - March



R:\7810\Cambridgeside 2.0\7810CHRT.dwg, 5/13/2020 12:1:46 PM

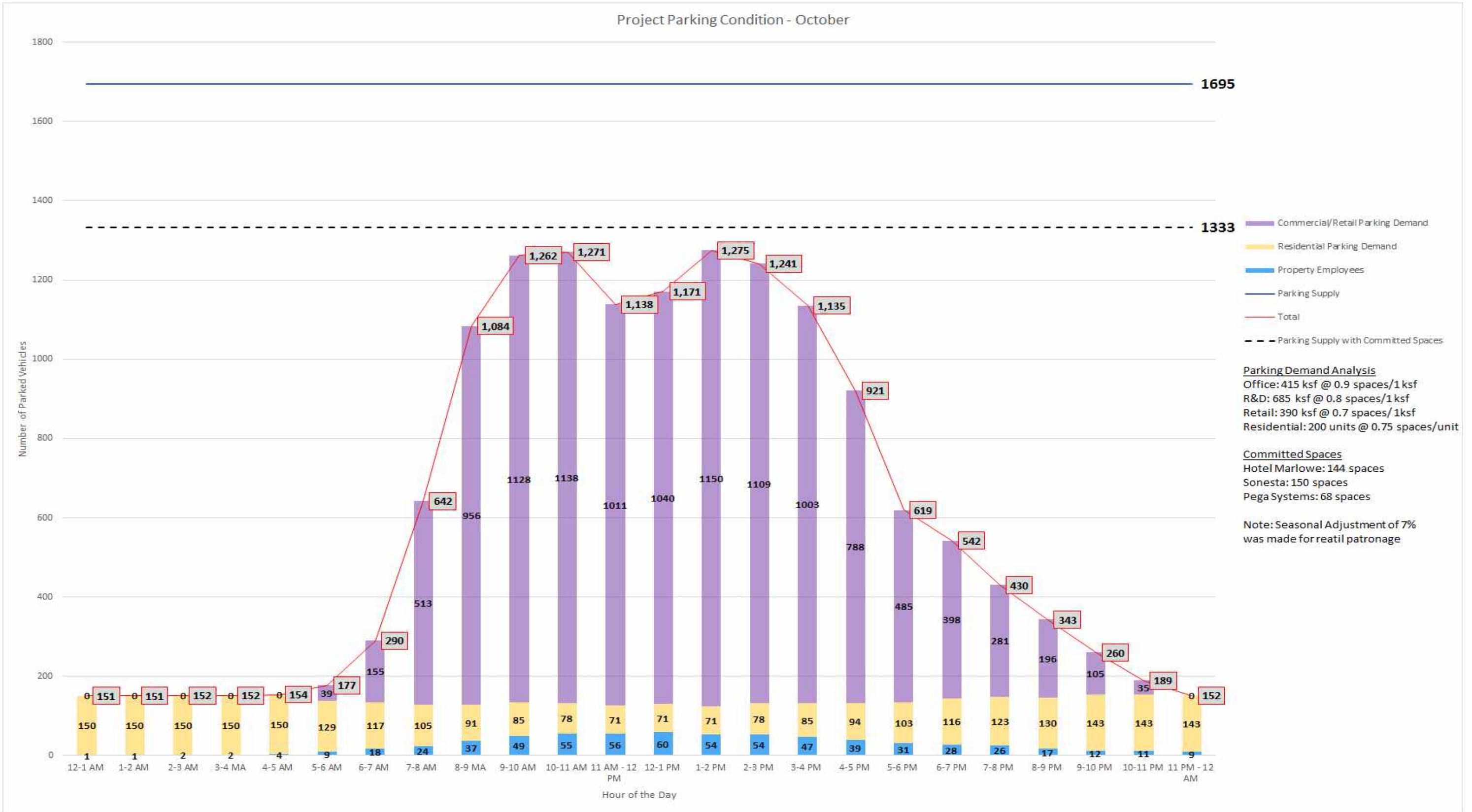


Figure 9.c.2
 Future Project
 Parking Condition - October



R:\7810\Cambridgeside 2.0\7810CHRT.dwg, 5/13/2020 1:22:11 PM

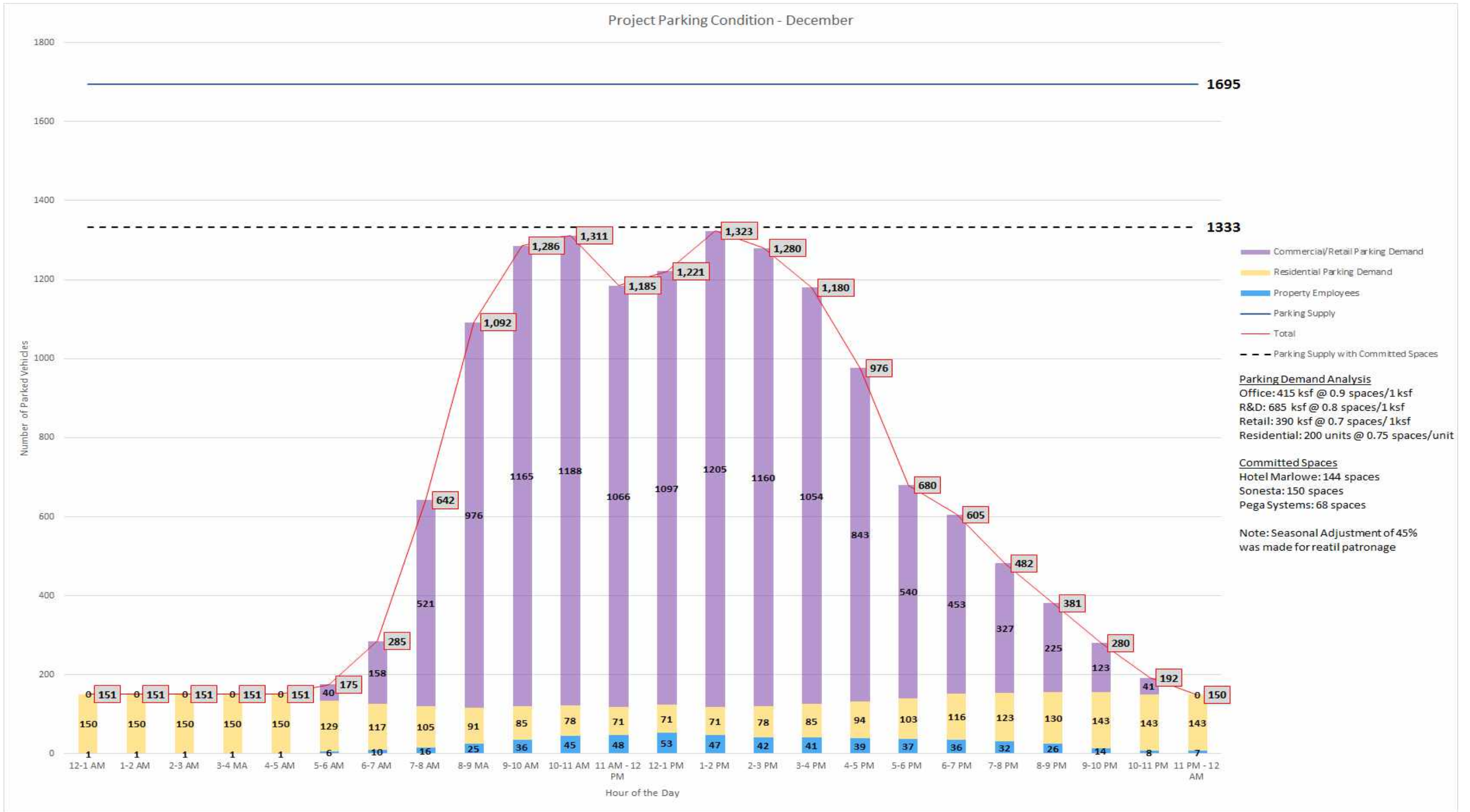


Figure 9.c.3

Future Project
 Parking Condition - December



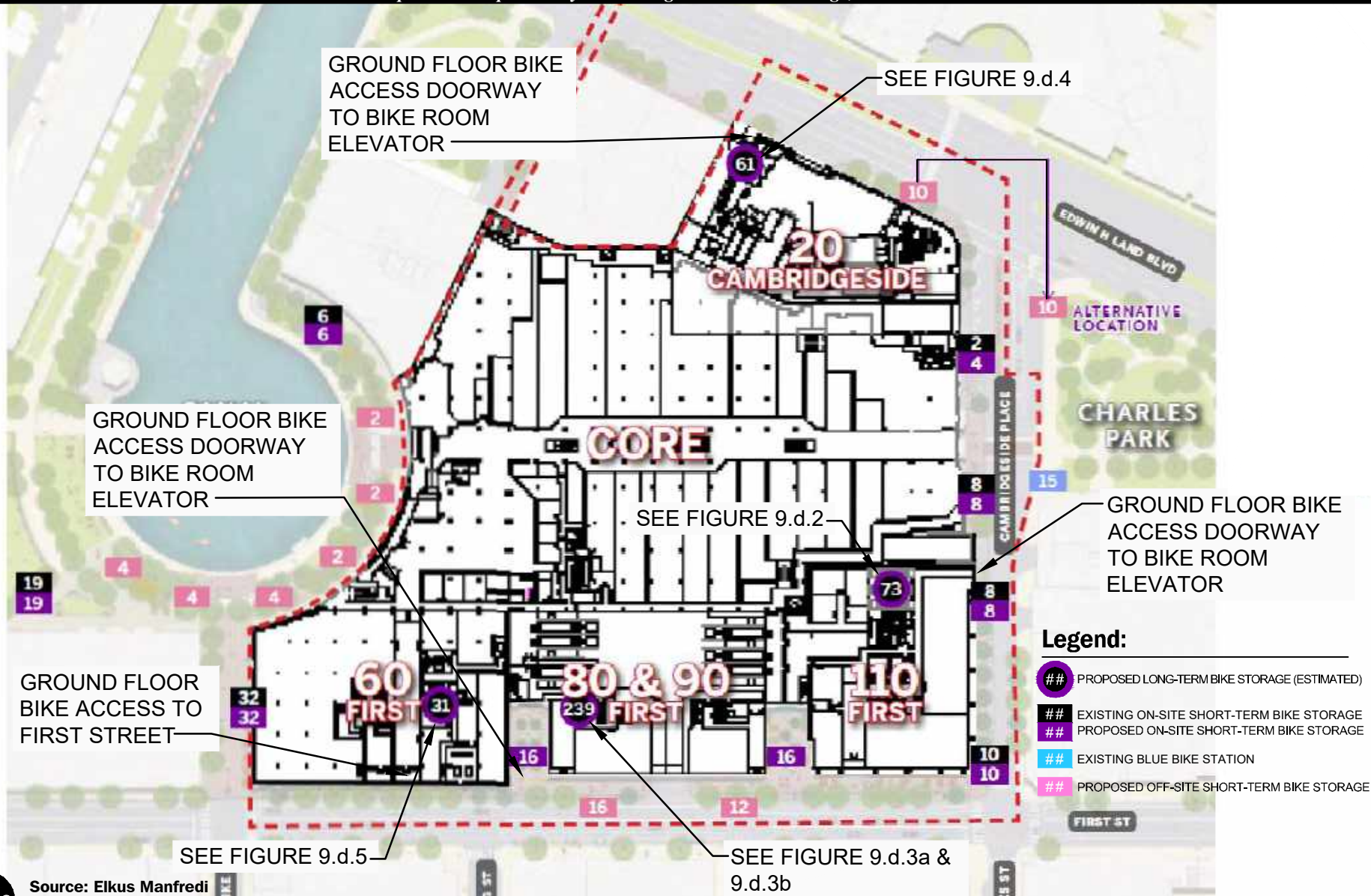
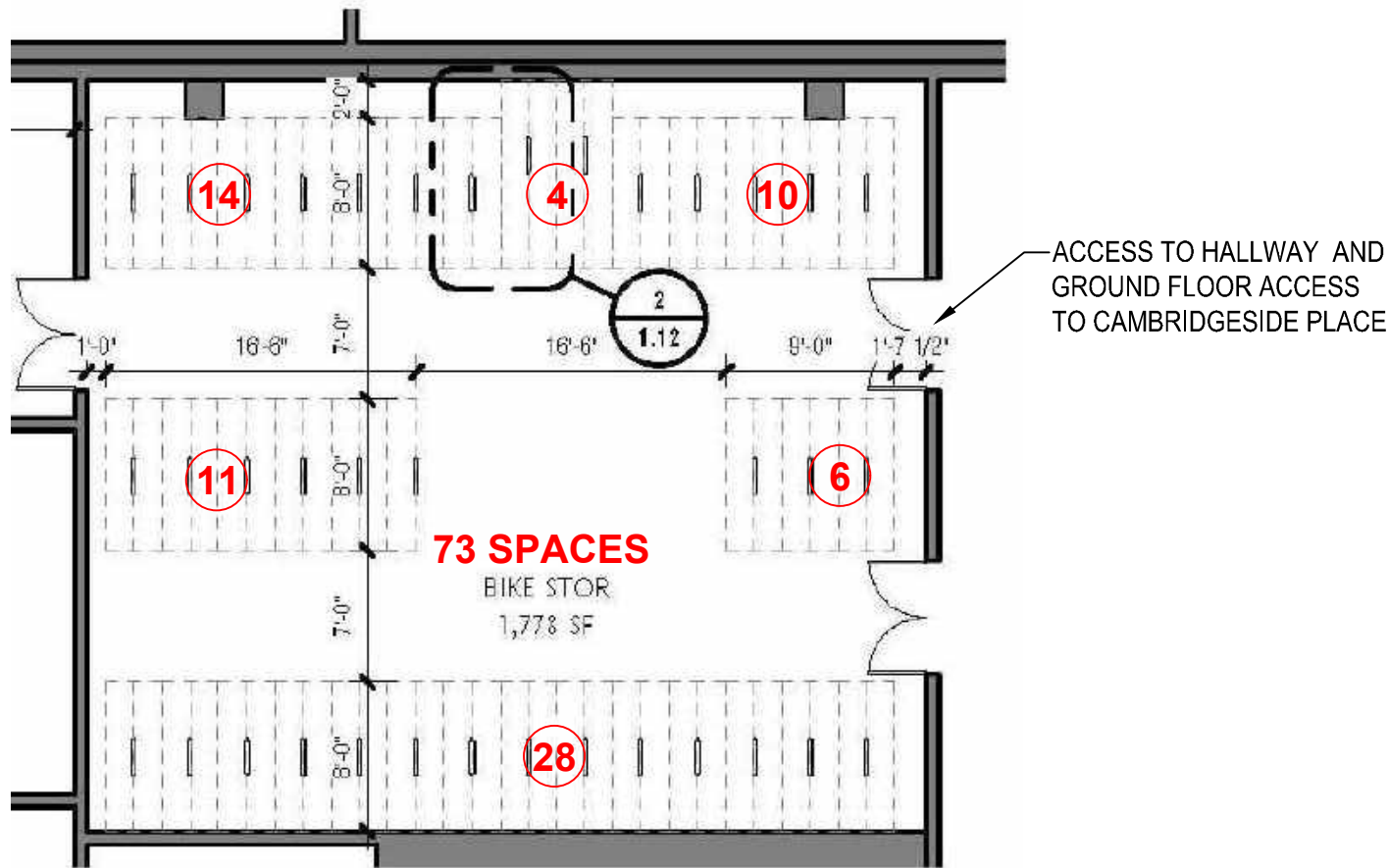


Figure 9.d.1
Proposed Bicycle Access and Storage



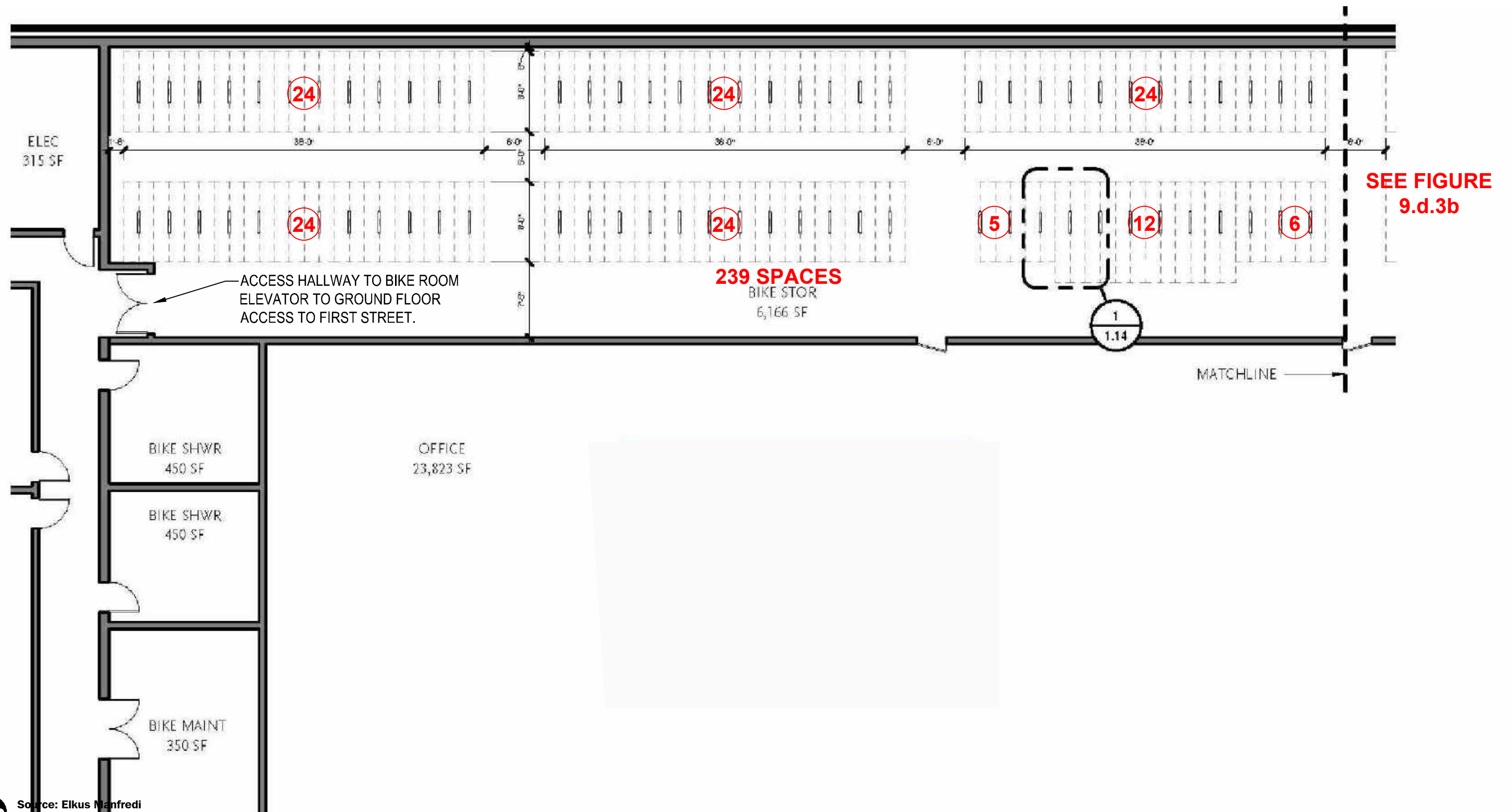
Source: Elkus Manfredi
0 5 10 Scale in Feet



Figure 9.d.5

110 First Street Bicycle Parking Plan

R:\7810\Cambridgeside 2.0\7810bikeracks.dwg, 7/16/2020 4:30:01 PM



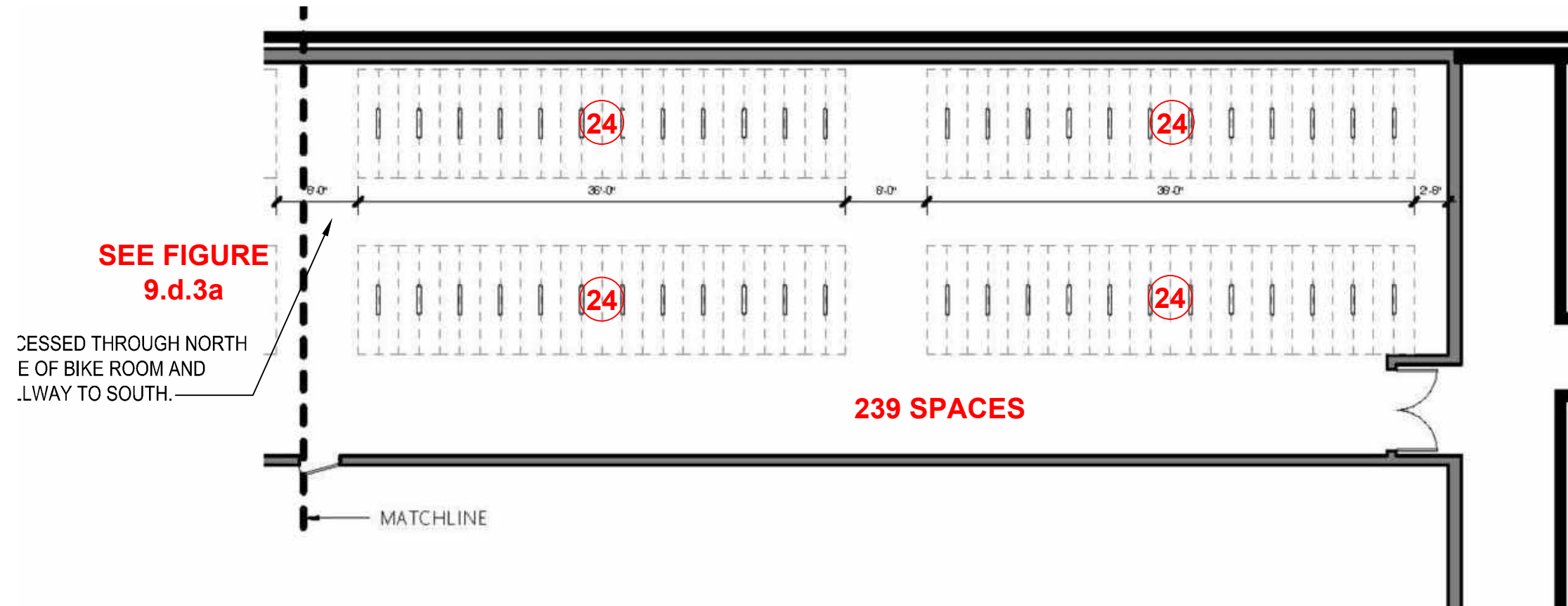
Source: Elkus Manfredi

0 5 10 Scale in Feet



Figure 9.d.3a

80 & 90 First Street
Bicycle Parking Plan - North

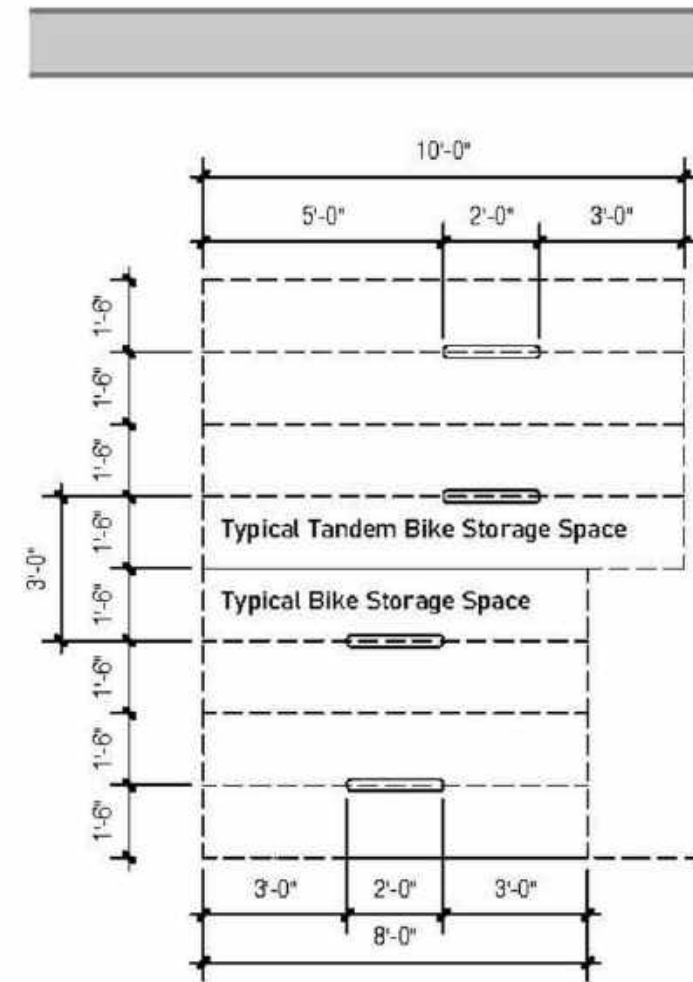
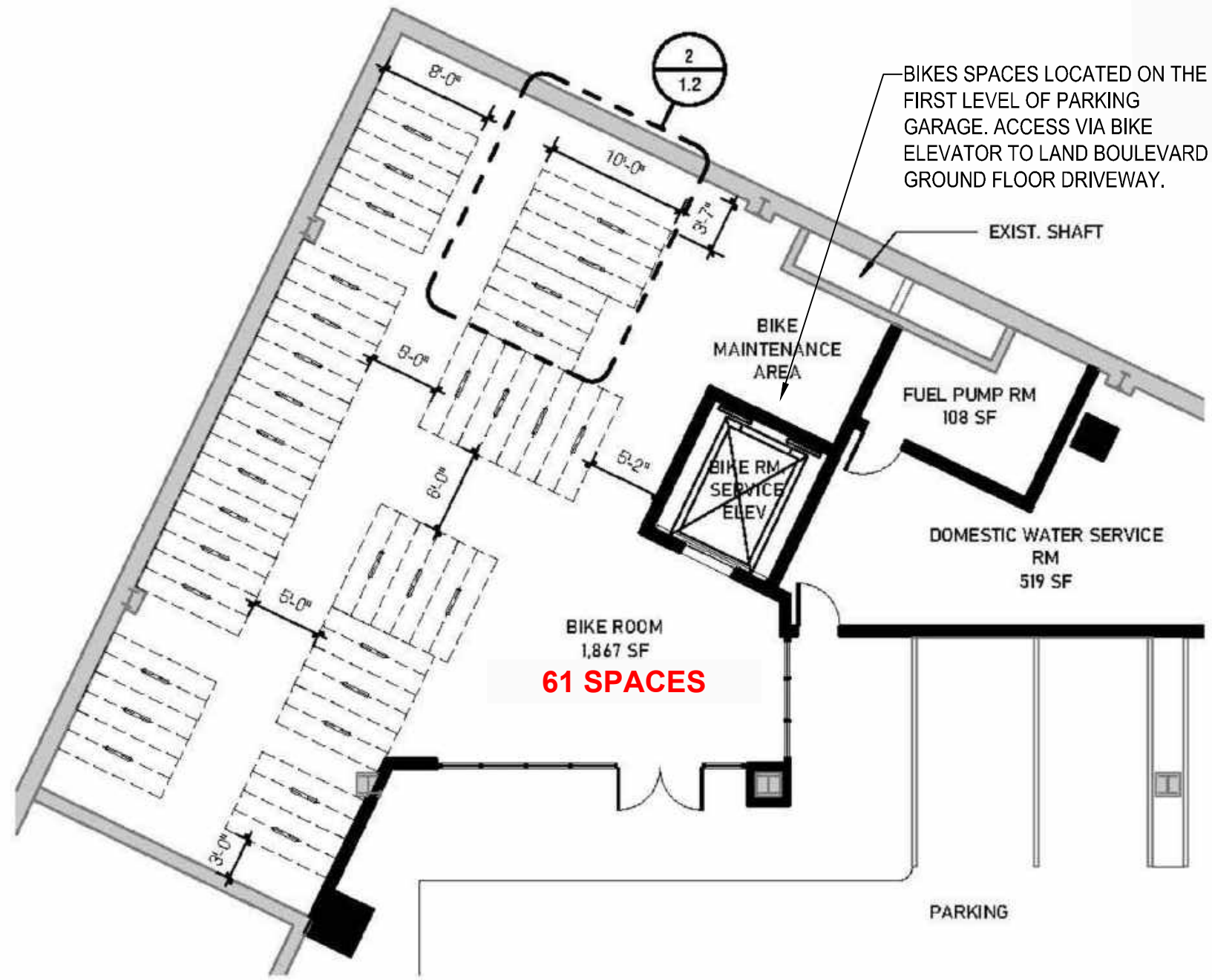


Source: Elkus Manfredi
0 5 10 Scale in Feet



Figure 9.d.3b

80 & 90 First Street
Bicycle Parking Plan - South

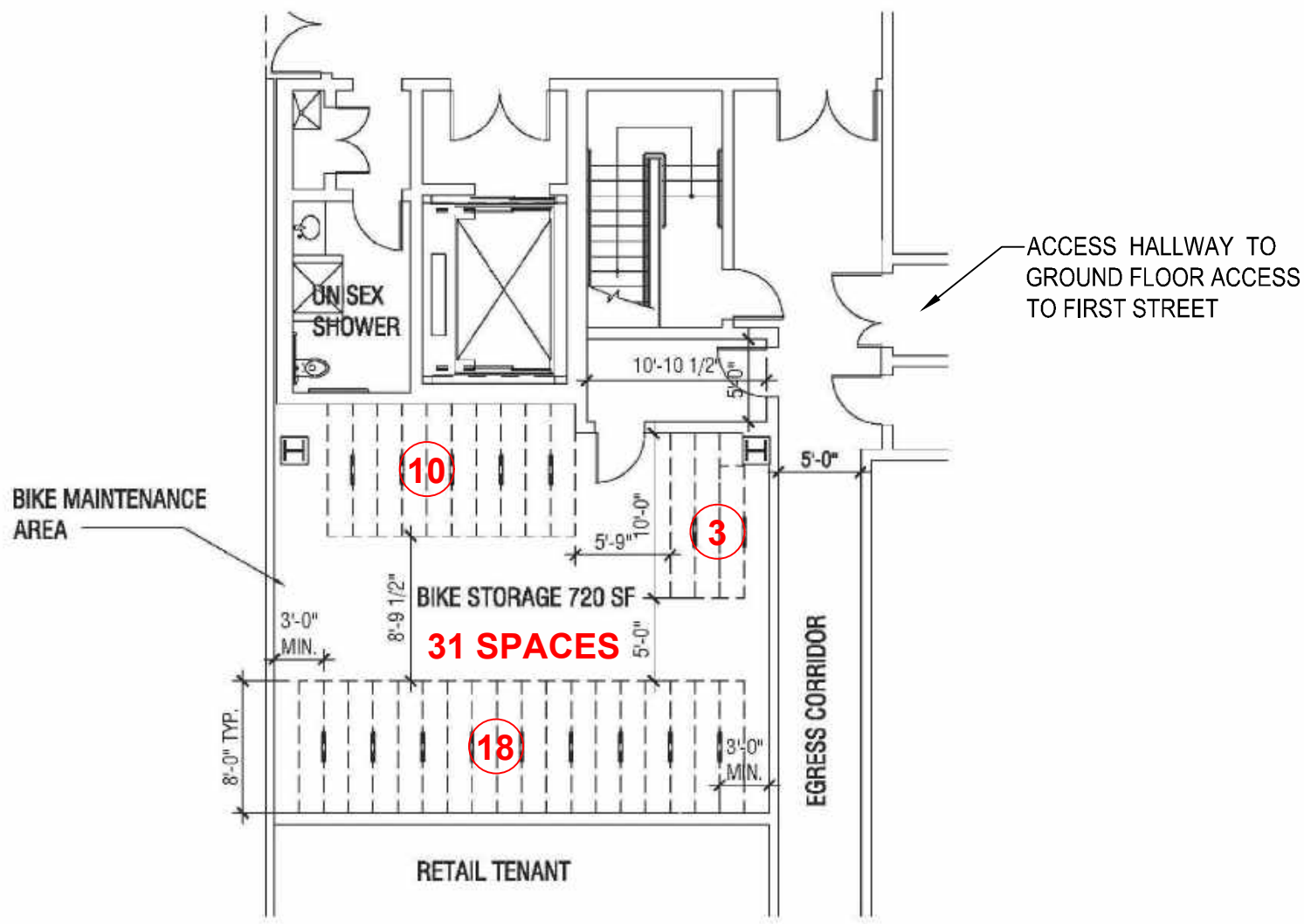


Source: Elkus Manfredi
0 5 10 Scale in Feet



Figure 9.d.4
20 CambridgeSide
Bicycle Parking Plan

R:\7810\Cambridgeside 2.0\7810bikeracks.dwg, 7/16/2020 4:31:20 PM



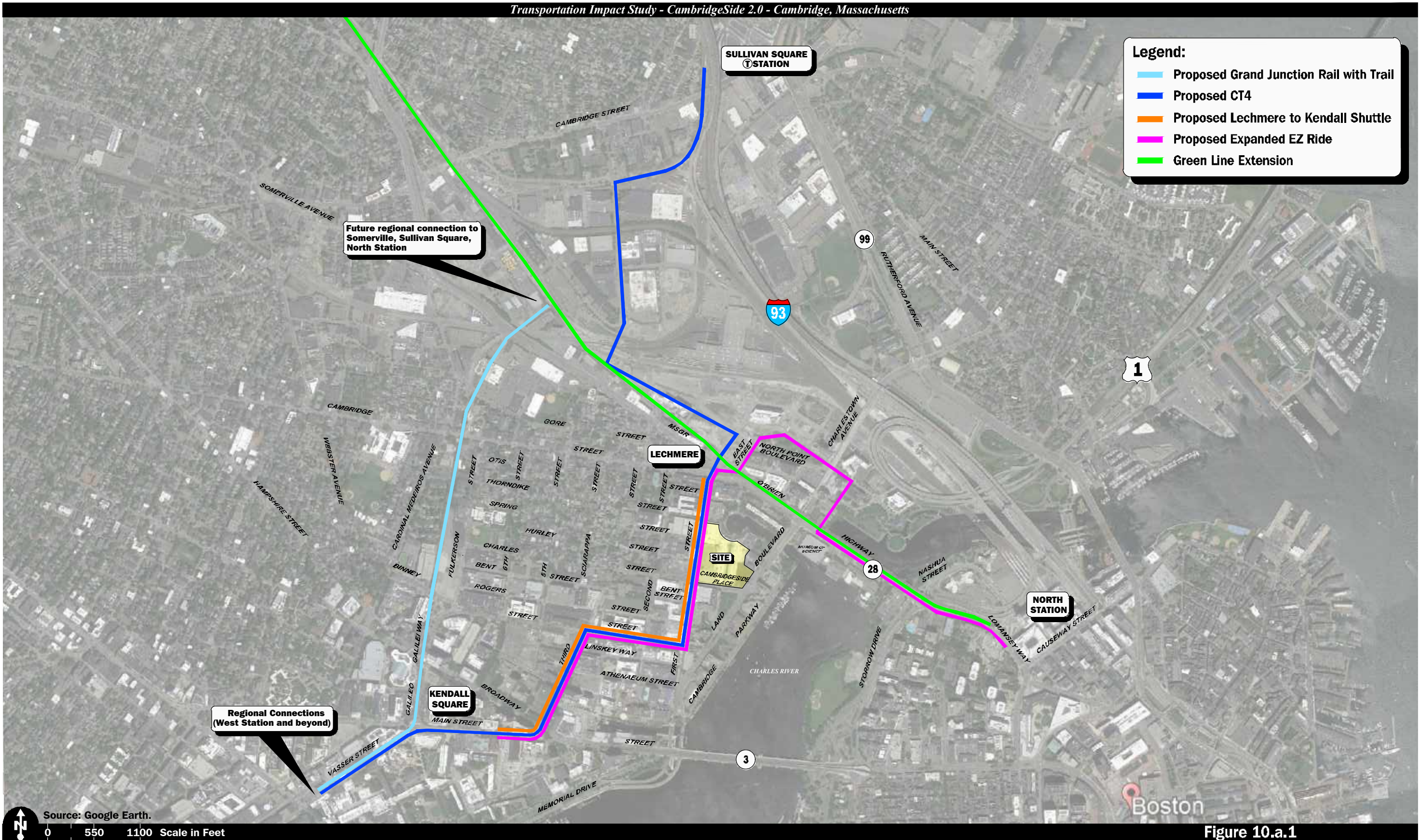
Source: Elkus Manfredi
0 5 10 Scale in Feet



Figure 9.d.5

60 First Street Bicycle Parking Plan

R:\7810\Cambridgeside 2.0\7810bikeracks.dwg, 7/16/2020 4:31:44 PM



Legend:

- Proposed Grand Junction Rail with Trail
- Proposed CT4
- Proposed Lechmere to Kendall Shuttle
- Proposed Expanded EZ Ride
- Green Line Extension

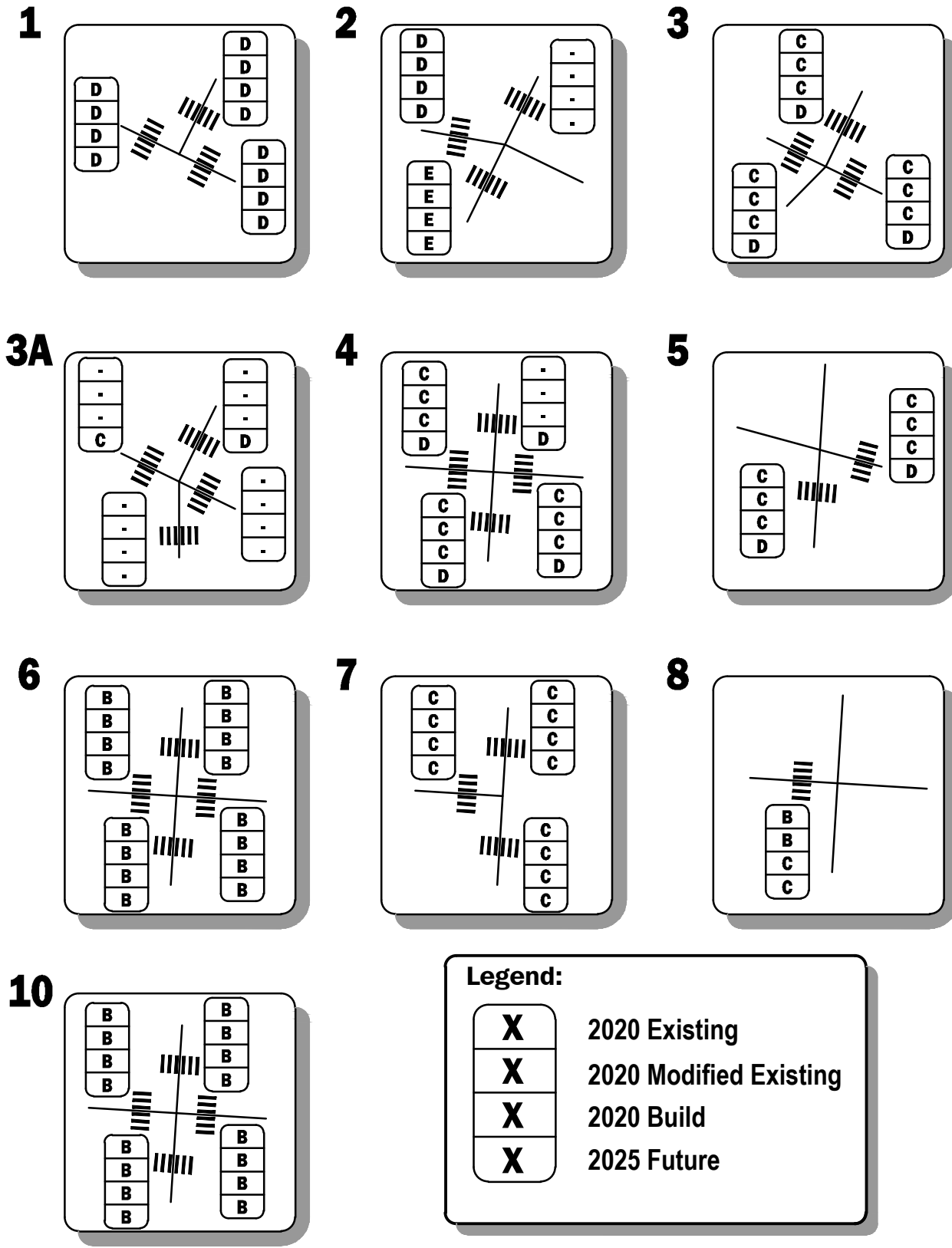
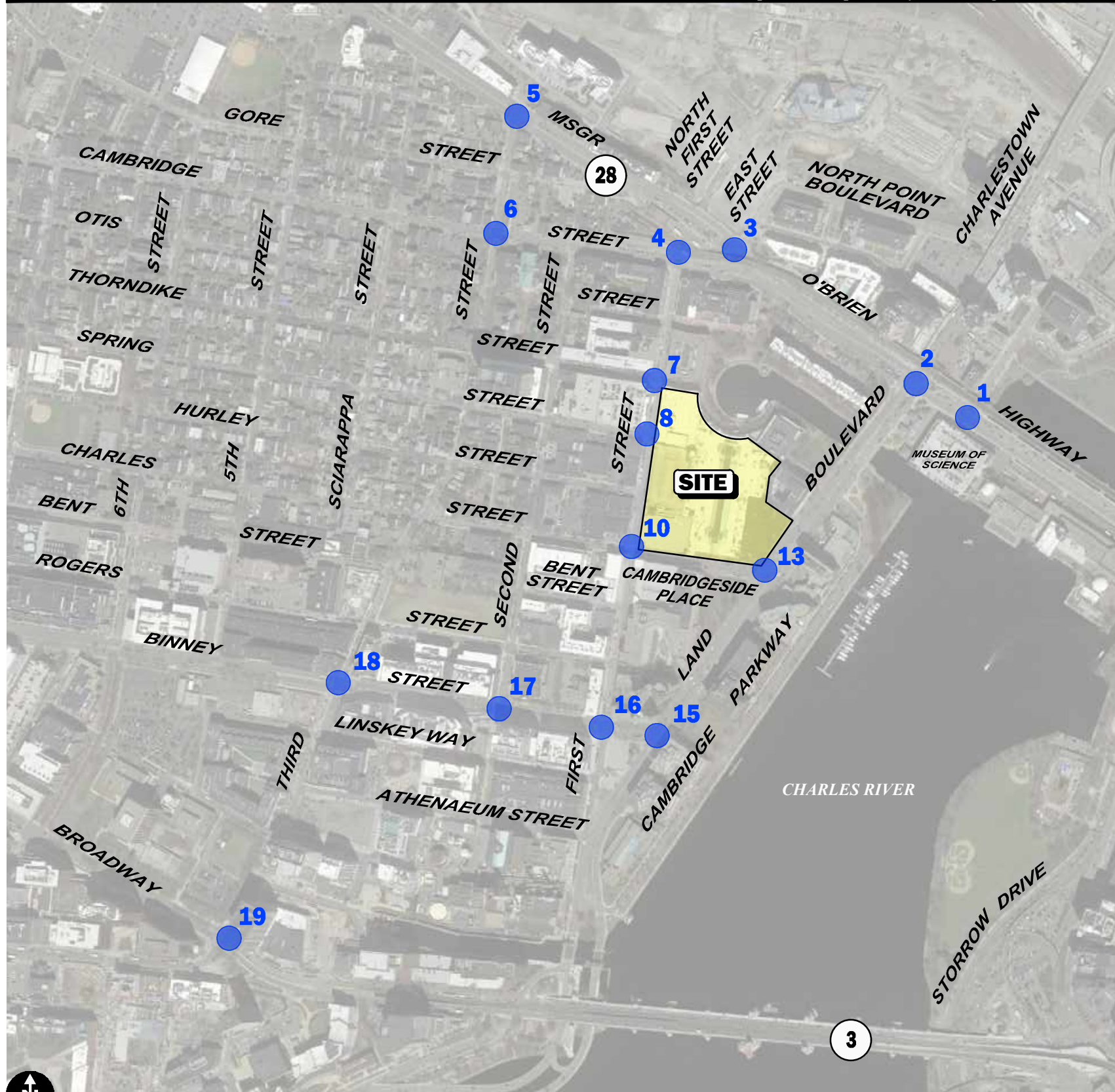
Future regional connection to Somerville, Sullivan Square, North Station

Regional Connections (West Station and beyond)

Figure 10.a.1

Future Transit and Pedestrian / Bicycle Facilities



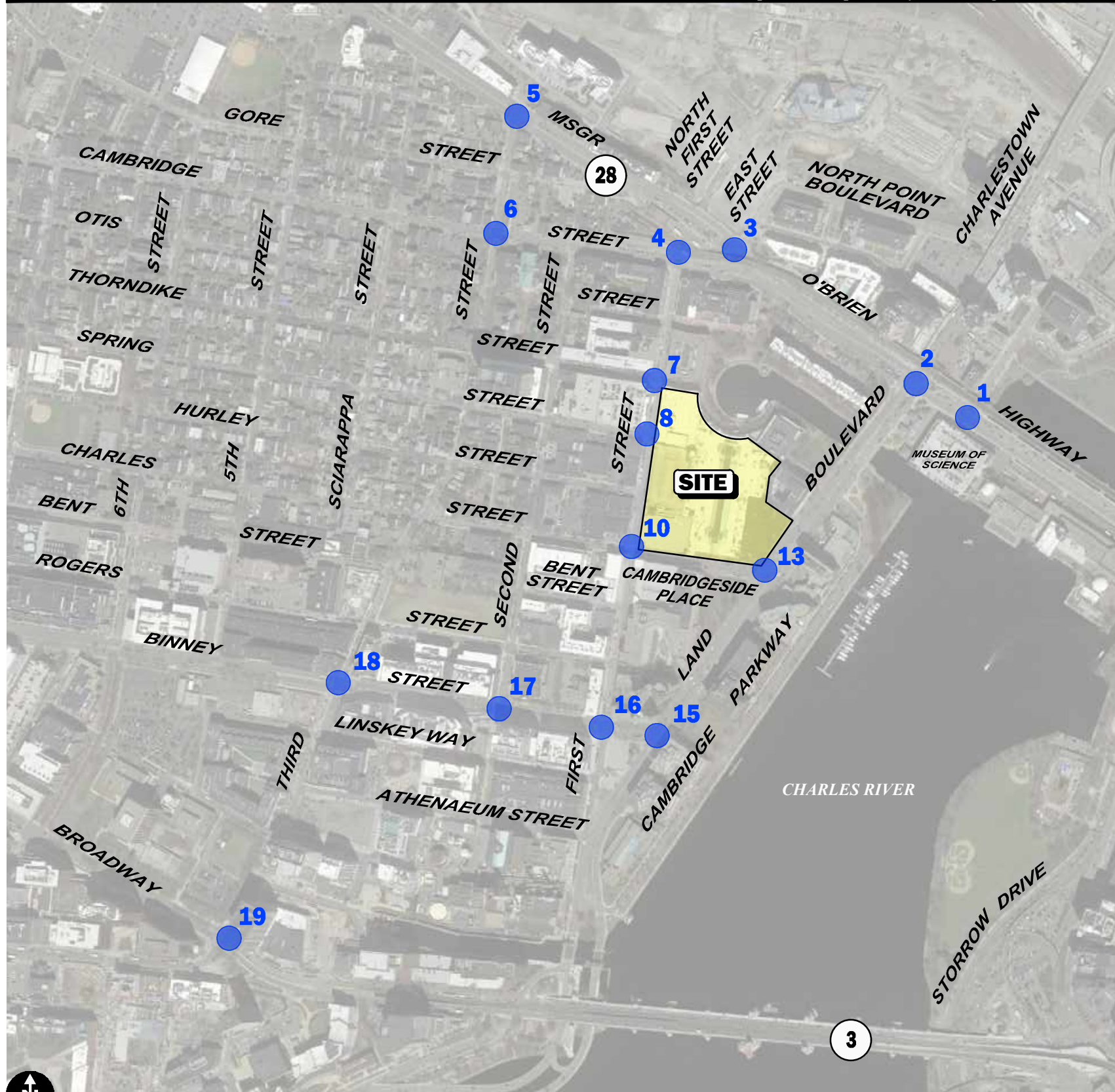


0 275 550 Scale in Feet

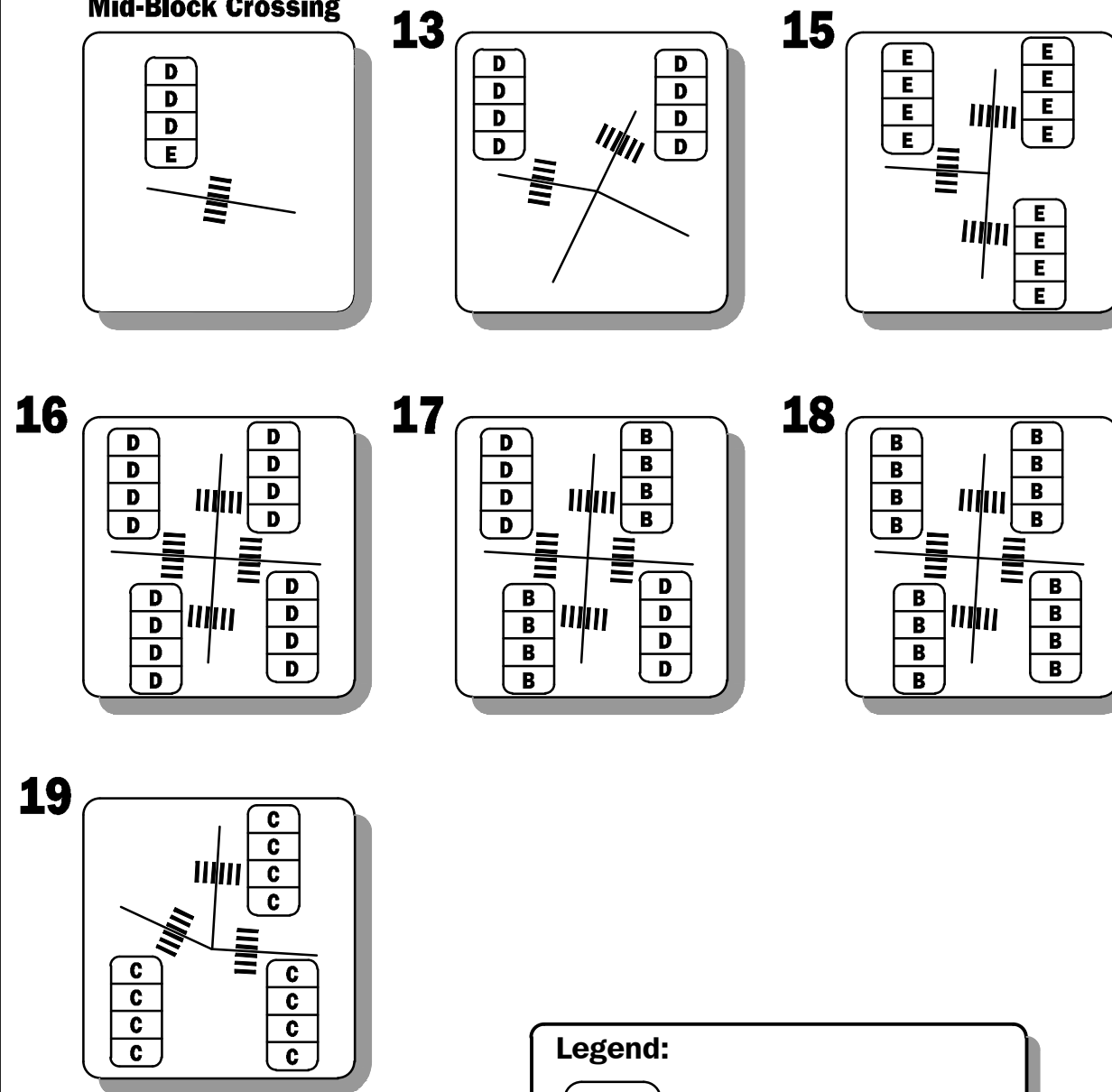


Figure 11.a.1
Pedestrian LOS Map
Weekday Morning Peak Hour
Sheet 1 of 2

R:\7810\Cambridgeside 2.0\7810NT8.dwg, 7/10/2020 12:06:47 PM



CambridgeSide Place at Mid-Block Crossing

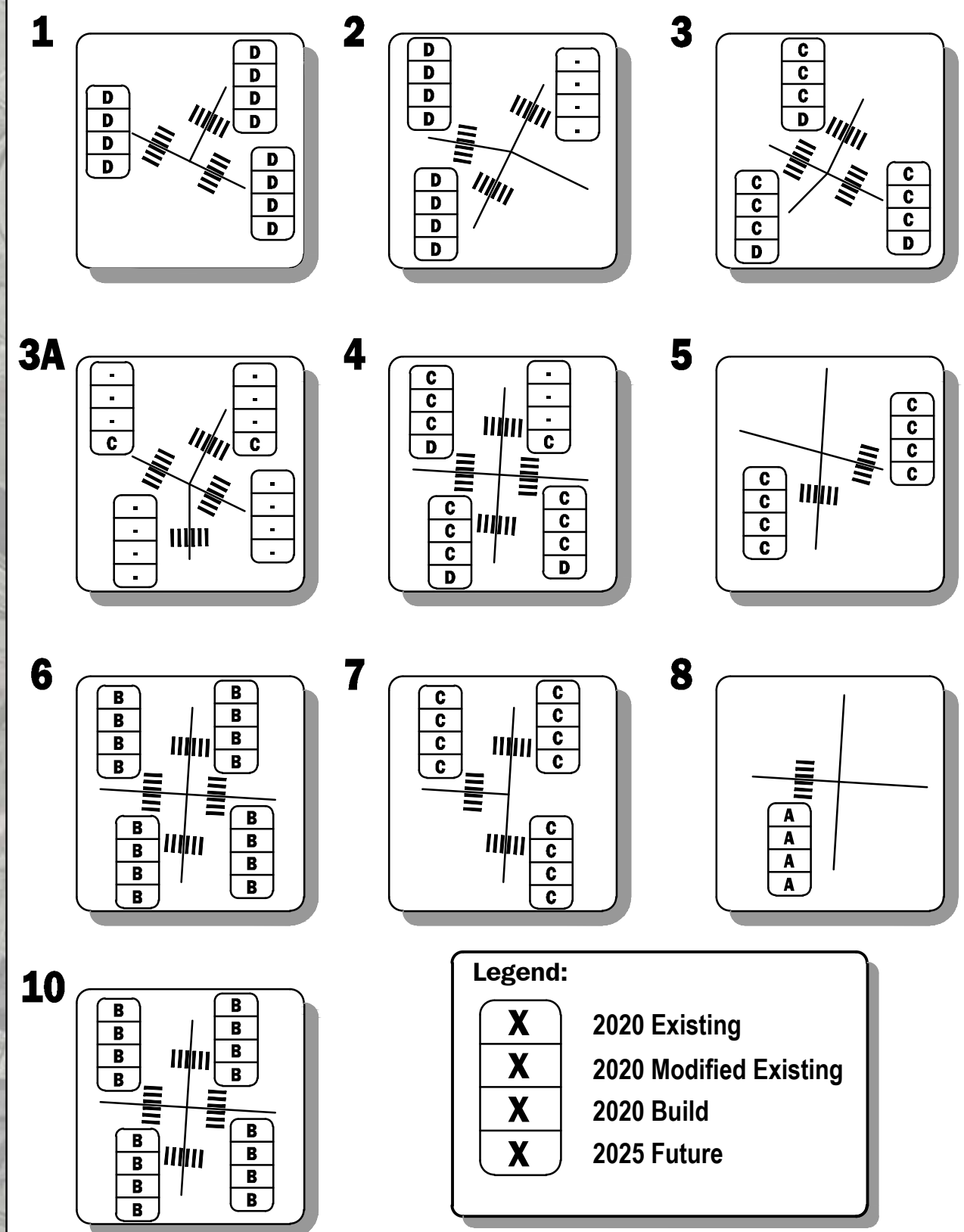
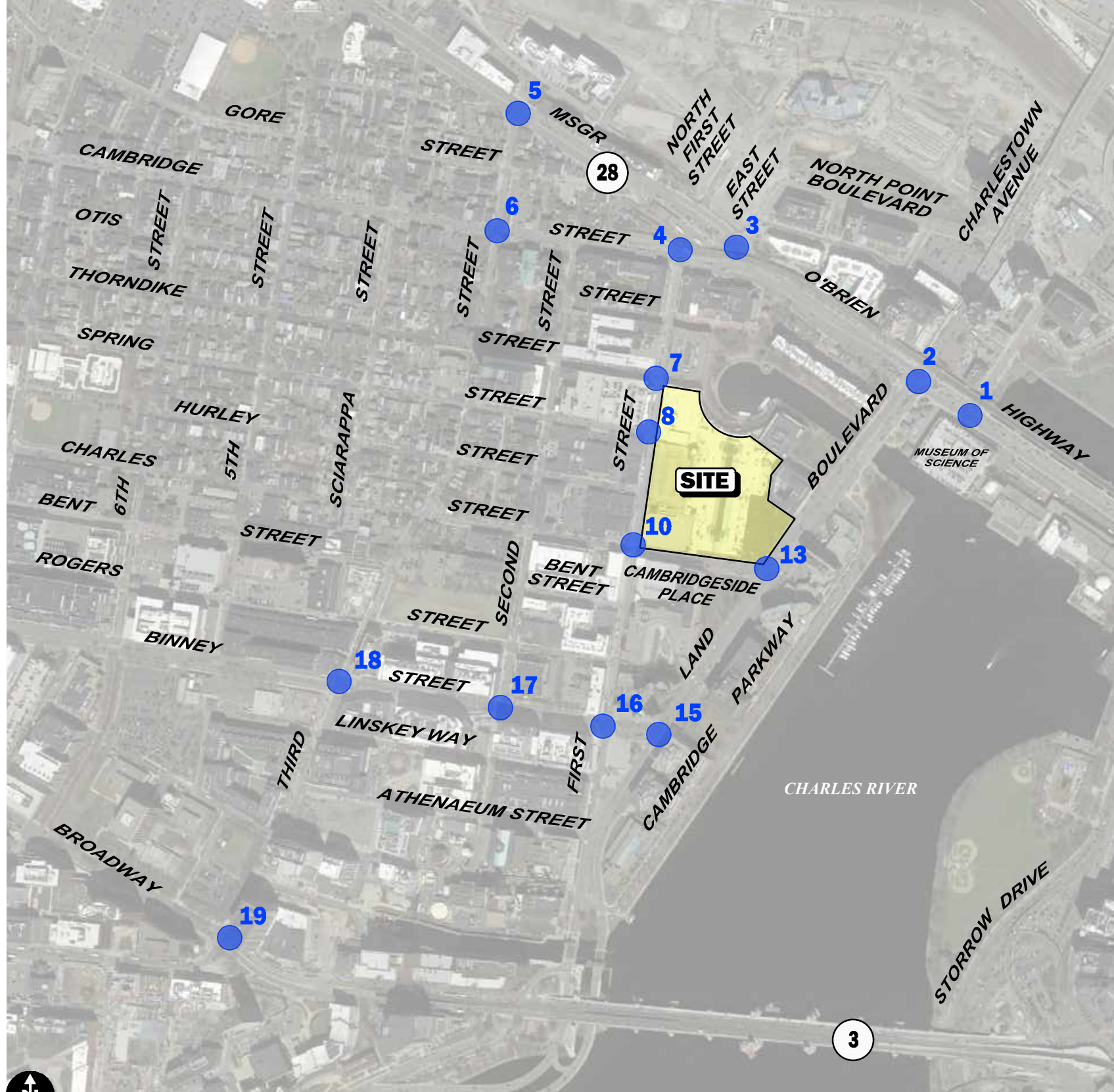


Legend:

X	2020 Existing
X	2020 Modified Existing
X	2020 Build
X	2025 Future

Figure 11.a.2

Pedestrian LOS Map
Weekday Morning Peak Hour
Sheet 2 of 2

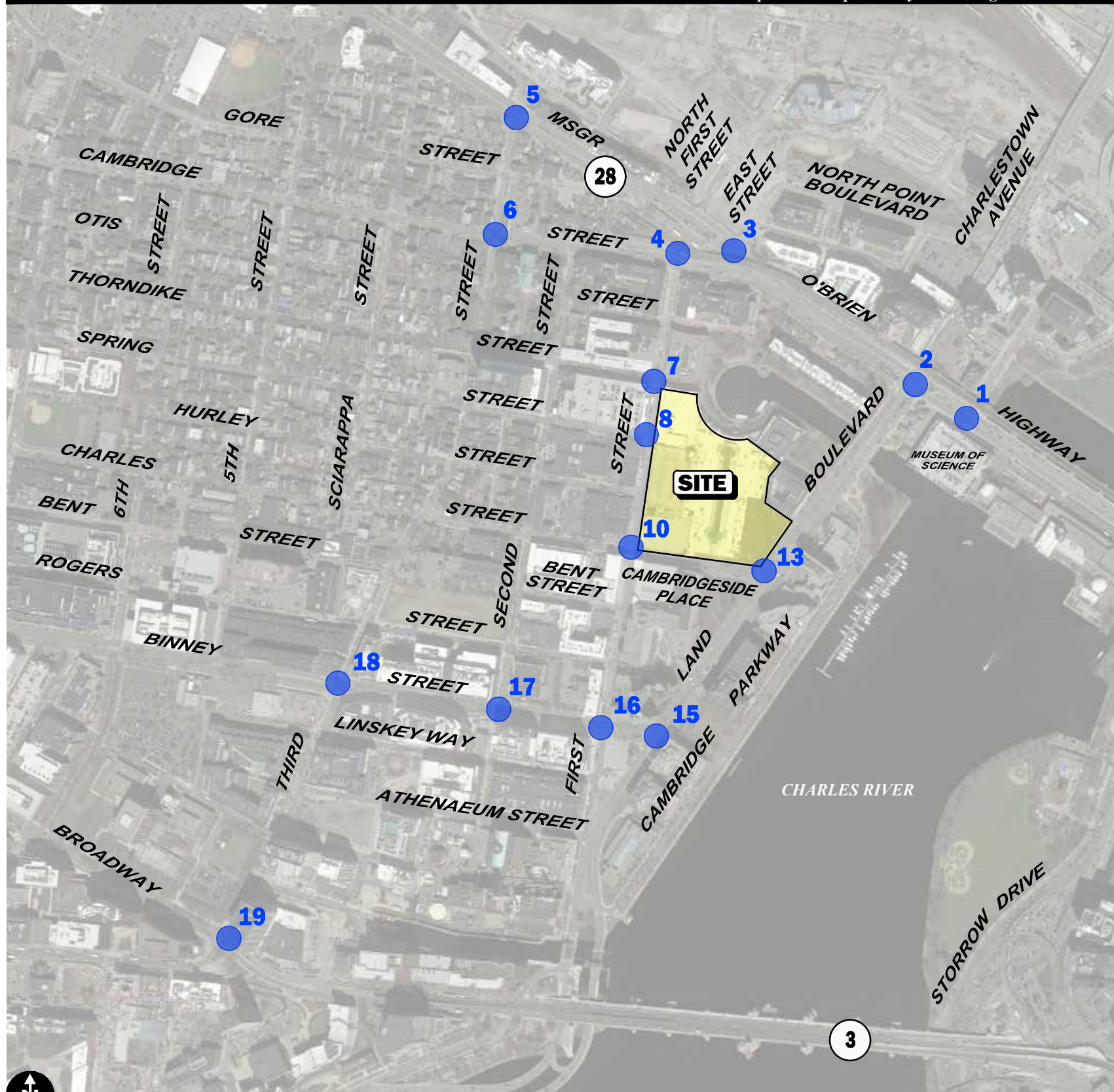


0 275 550 Scale in Feet

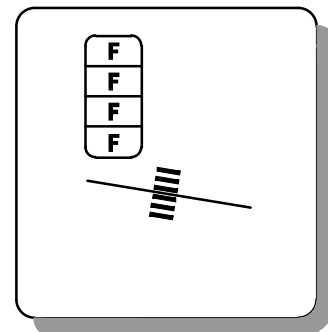


Figure 11.a.3
Pedestrian LOS Map
Weekday Evening Peak Hour
Sheet 1 of 2

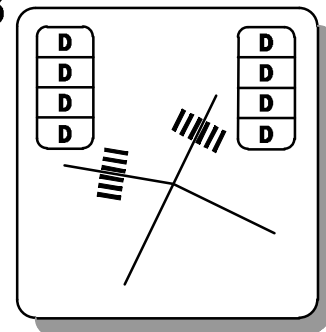
R:\7810\Cambridgeside 2.0\7810NT8.dwg, 7/10/2020 12:07:40 PM



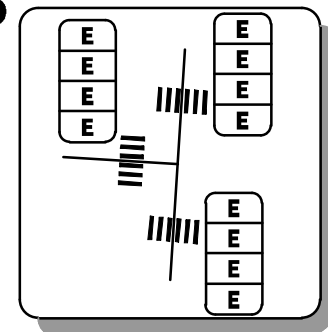
CambridgeSide Place at Mid-Block Crossing



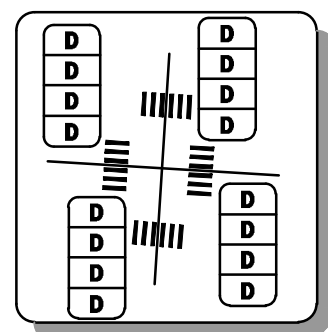
13



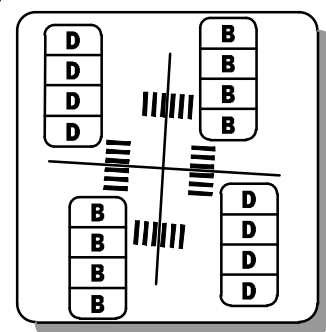
15



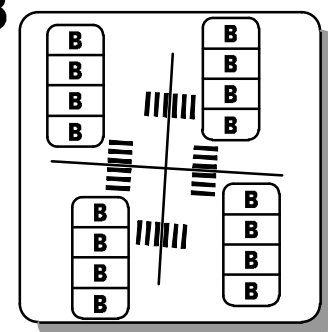
16



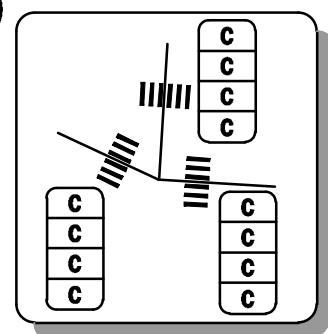
17



18



19

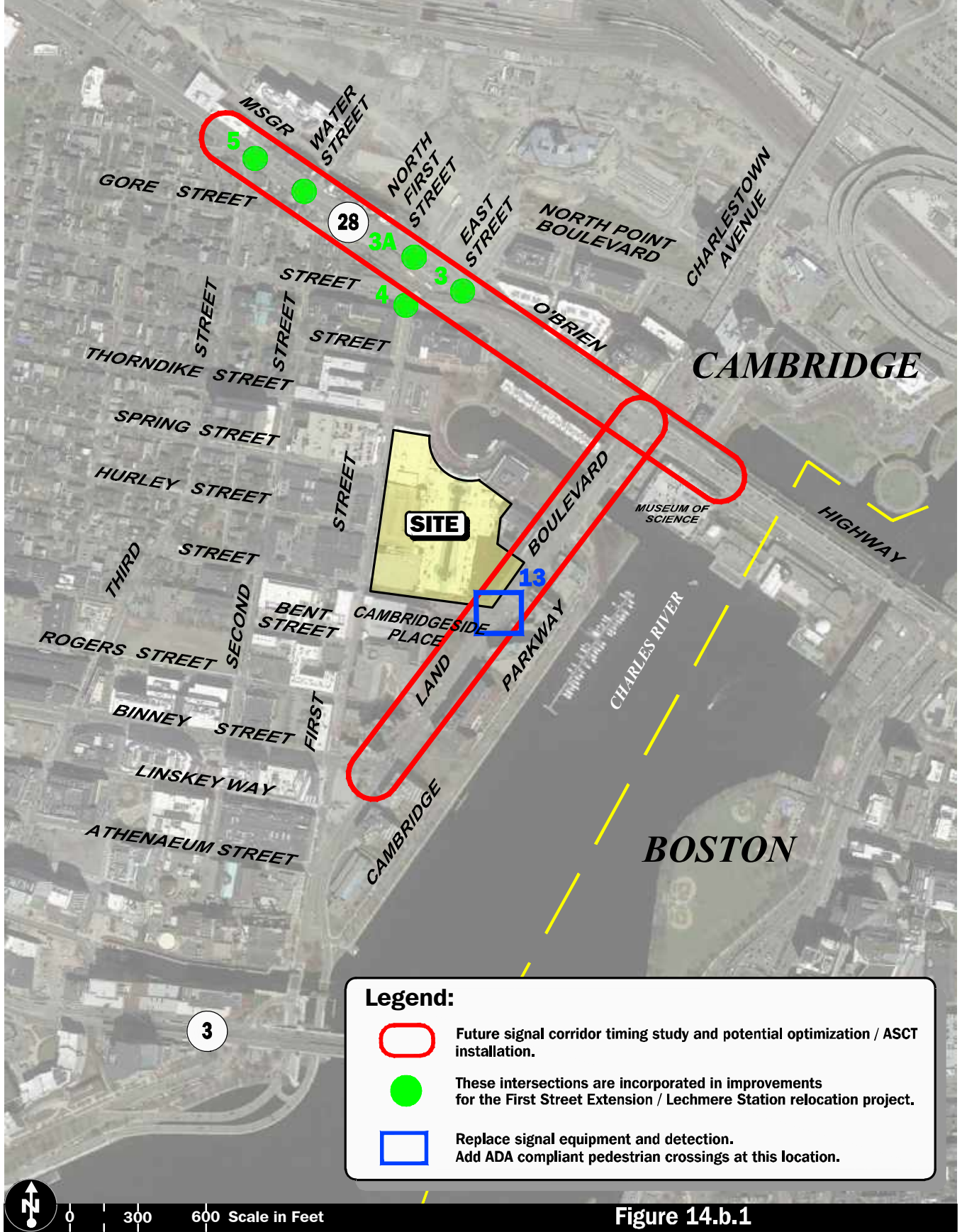


Legend:

X	2020 Existing
X	2020 Modified Existing
X	2020 Build
X	2025 Future

Figure 11.a.4

Pedestrian LOS Map
Weekday Evening Peak Hour
Sheet 2 of 2



Legend:

- Future signal corridor timing study and potential optimization / ASCT installation.
- These intersections are incorporated in improvements for the First Street Extension / Lechmere Station relocation project.
- Replace signal equipment and detection. Add ADA compliant pedestrian crossings at this location.

Figure 14.b.1

Proposed Roadway Mitigation



Planning Board Permit Number: _____

Project Name: CambridgeSide 2.0 Redevelopment

Total Data Entries = 379

Total Number of Criteria Exceedances = 20

1. Project Vehicle Trip Generation

Weekday = 860 AM Peak Hour = 132 PM Peak Hour = 92 Exceeds Criteria? [Y/N] | N/N/N



2. Level of Service (LOS)

Intersection	Weekday Morning Peak Hour			Weekday Evening Peak Hour		
	Modified Baseline	With Project	Exceeds Criteria?	Modified Baseline	With Project	Exceeds Criteria?
O'Brien Highway at Museum Way	C	C	N	C	C	N
O'Brien Highway at Land Boulevard/Charlestown Avenue	F	F	N	F	F	N
O'Brien Highway at Cambridge Street/East Street	F	E	N	C	D	N
Cambridge Street at First Street	B	B	N	D	E	Y
O'Brien Highway at Third Street	E	E	N	D	C	N
Cambridge Street at Third Street	C	C	N	D	D	N
First Street at Thorndike Street	A	A	N	C	E	Y
First Street at Charles Street and Cambridgeside Place	B	B	N	E	F	Y
Land Boulevard at Cambridgeside Place and Hotel Driveway	B	D	N	C	D	N
Land Boulevard at Binney Street	D	D	N	B	B	N
Land Boulevard at First Street	B	B	N	C	D	N
Binney Street at Second Street	C	C	N	C	C	N
Binney Street at Third Street	C	C	N	D	D	N
Broadway at Third Street	C	C	N	C	C	N
Cambridgeside Place at Garage South Exit						
SB LT	A	A	N	F	F	Y
SB RT	A	A	N	B	C	N
First Street at Garage West Entrance						
NB TH/RT	A	A	N	A	B	N
SB LT/TH	A	A	N	F	F	Y
Cambridgeside Place at Garage South Entrance						
EB TH	A	A	N	F	F	N
WB TH	A	A	N	A	A	N
WB RT	A	A	N	A	A	N



3. Traffic on Residential Streets

Street Segment	Weekday Morning Peak Hour			Weekday Evening Peak Hour		
	Modified Baseline Volume	With Project	Exceeds Criteria?	Modified Baseline Volume	With Project	Exceeds Criteria?
Charles Street, Second Street to First Street (Amount of residential = <1/3)	107	120	N	228	229	N
Third Street, O'Brien Highway to Cambridge Street (Amount of residential = >1/3 but <1/2)	856	870	N	1,217	1,231	N



4. Lane Queue (for Signalized Intersections Critical Lane)

Intersection	No. of	Weekday Morning Peak Hour			Weekday Evening Peak Hour		
	Lanes Analyzed	Modified Baseline	With Project	Exceeds Criteria?	Modified Baseline	With Project	Exceeds Criteria?
<i>O'Brien Highway at Museum Way:</i>	7						
O'Brien Highway EB LT		2	2	N	2	2	N
O'Brien Highway EB TH		5	5	N	4	4	N
O'Brien Highway EB TH		5	5	N	5	5	N
O'Brien Highway WB TH		10	10	N	10	10	N
O'Brien Highway WB TH		7	6	N	9	9	N
O'Brien Highway WB TH/RT		2	2	N	5	7	N
Museum Way SB LT/RT	7	7	N	4	5	N	
<i>O'Brien Highway at Land Boulevard /Charlestown Avenue:</i>	16						
O'Brien Highway EB LT		3	3	N	9	9	N
O'Brien Highway EB LT		19	19	N	17	27	Y
O'Brien Highway EB TH		27	28	N	13	20	Y
O'Brien Highway EB TH		27	29	N	10	15	N
O'Brien Highway EB RT		16	16	N	0	0	N
O'Brien Highway WB LT		8	8	N	8	8	N
O'Brien Highway WB TH		3	4	N	6	7	N
O'Brien Highway WB TH		4	4	N	6	6	N
O'Brien Highway WB RT		4	4	N	6	6	N
Land Boulevard NB LT		6	4	N	23	24	N
Land Boulevard NB TH		16	14	N	32	32	N
Land Boulevard NB TH		16	15	N	32	32	N
Land Boulevard NB RT		5	5	N	23	27	N
Charlestown Avenue SB LT/TH		10	10	N	7	6	N
Charlestown Avenue SB LT/TH	16	16	N	14	14	N	
Charlestown Avenue SB TH/RT	16	16	N	16	15	N	
<i>O'Brien Highway at Cambridge Street /East Street:</i>	13						
O'Brien Highway EB LT		3	3	N	4	4	N
O'Brien Highway EB TH		16	10	N	10	8	N
O'Brien Highway EB TH		18	12	N	9	7	N
O'Brien Highway EB TH		19	13	N	7	5	N
O'Brien Highway EB RT		2	3	N	1	1	N
O'Brien Highway WB LT		3	3	N	2	3	N
O'Brien Highway WB LT		2	3	N	3	4	N
O'Brien Highway WB TH		2	2	N	7	7	N
O'Brien Highway WB TH/RT		2	2	N	8	7	N
Cambridge Street NB LT/TH		2	2	N	3	3	N
Cambridge Street NB RT		1	2	N	2	2	N
Cambridge Street NB RT		1	1	N	1	1	N
East Street SB LT/TH/RT	2	2	N	2	2	N	



Intersection	No. of	Weekday Morning Peak Hour			Weekday Evening Peak Hour		
	Lanes Analyzed	Modified Baseline	With Project	Exceeds Criteria?	Modified Baseline	With Project	Exceeds Criteria?
Cambridge Street at First Street:	6						
Cambridge Street EB TH/RT		3	5	N	9	14	N
Cambridge Street WB LT		4	4	N	3	3	N
Cambridge Street WB TH		2	2	N	3	2	N
First Street NB LT		1	2	N	5	5	N
First Street NB RT		3	3	N	8	8	N
Bus Station SB LT/TH/RT		0	0	N	0	0	N
O'Brien Highway at Third Street:	8						
O'Brien Highway EB TH		14	16	N	7	7	N
O'Brien Highway EB TH		14	18	N	6	6	N
O'Brien Highway EB TH/RT		15	19	N	6	6	N
O'Brien Highway WB LT/TH		2	2	N	13	13	N
O'Brien Highway WB TH		2	2	N	14	12	N
O'Brien Highway WB TH		2	2	N	14	13	N
Third Street NB LT		2	2	N	4	3	N
Third Street NB LT/RT	10	4	N	7	6	N	
Cambridge Street at Third Street:	5						
Cambridge Street EB LT/TH/RT		8	9	N	10	10	N
Cambridge Street WB LT/TH/RT		5	6	N	9	8	N
Third Street NB LT/TH/RT		4	4	N	9	9	N
Third Street SB LT		2	2	N	1	1	N
Third Street SB TH/RT	9	9	N	4	4	N	
First Street at Thorndike Street:	4						
Thorndike Street EB LT		1	1	N	2	2	N
Thorndike Street EB RT		2	2	N	2	5	N
First Street NB TH		2	2	N	11	7	N
First Street SB TH	4	4	N	7	10	N	
First Street at Charles Street and Cambridgeside Place:	4						
Charles Street EB LT/TH/RT		2	2	N	6	8	N
Cambridgeside Place WB LT/ RT		3	3	N	5	6	N
First Street NB TH/RT		3	3	N	5	12	N
First Street SB LT/TH	3	3	N	7	7	N	



Intersection	No. of	Weekday Morning Peak Hour			Weekday Evening Peak Hour		
	Lanes Analyzed	Modified Baseline	With Project	Exceeds Criteria?	Modified Baseline	With Project	Exceeds Criteria?
<i>Land Boulevard at Cambridgeside Place and Hotel Driveway:</i>	12						
Cambridgeside Place EB LT		2	2	N	12	11	N
Cambridgeside Place EB LT/TH		2	2	N	12	11	N
Cambridgeside Place EB RT		0	0	N	0	0	N
Hotel Driveway WB LT/TH/RT		2	1	N	2	3	N
Land Boulevard NB LT		4	10	N	7	9	N
Land Boulevard NB TH		3	22	Y	10	14	N
Land Boulevard NB TH		3	16	Y	8	12	N
Land Boulevard NB TH/RT		3	3	N	5	7	N
Land Boulevard SB LT		6	8	N	4	6	N
Land Boulevard SB TH		7	9	N	6	6	N
Land Boulevard SB TH		9	10	N	7	5	N
Land Boulevard SB TH/RT	2	2	N	2	2	N	
<i>Land Boulevard at Binney Street:</i>	10						
Binney Street EB LT		2	3	N	3	3	N
Binney Street EB LT		3	3	N	3	3	N
Land Boulevard NB LT		17	18	N	6	6	N
Land Boulevard NB LT		17	17	N	4	5	N
Land Boulevard NB TH		11	13	N	10	10	N
Land Boulevard NB TH		5	4	N	7	7	N
Land Boulevard NB TH		2	2	N	3	3	N
Land Boulevard SB TH		11	11	N	5	6	N
Land Boulevard SB TH		11	11	N	6	7	N
Land Boulevard SB RT	7	7	N	1	1	N	
<i>Binney Street at First Street:</i>	8						
Binney Street EB LT		2	3	N	1	2	N
Binney Street EB TH		2	2	N	2	2	N
Binney Street EB TH/RT		3	3	N	3	3	N
Binney Street WB LT/TH		5	5	N	2	2	N
Binney Street WB TH/RT		5	5	N	2	2	N
First Street NB LT/TH/RT		3	3	N	2	2	N
First Street SB LT/TH		4	5	N	10	11	N
First Street SB RT	2	2	N	3	3	N	
<i>Binney Street at Second Street:</i>	7						
Binney Street EB LT		1	1	N	2	2	N
Binney Street EB TH/RT		5	6	N	4	5	N
Binney Street WB LT		2	2	N	1	1	N
Binney Street WB TH		6	6	N	4	4	N
Binney Street WB TH/RT		6	6	N	4	4	N
Second Street NB LT/TH/RT		2	2	N	6	7	N
Second Street SB LT/TH/RT	5	5	N	3	3	N	



Intersection	No. of	Weekday Morning Peak Hour			Weekday Evening Peak Hour		
	Lanes Analyzed	Modified Baseline	With Project	Exceeds Criteria?	Modified Baseline	With Project	Exceeds Criteria?
<i>Binney Street at Third Street:</i>	9						
Binney Street EB LT		2	2	N	7	7	N
Binney Street EB TH		4	4	N	6	9	N
Binney Street EB TH/RT		3	3	N	4	7	N
Binney Street WB LT		4	5	N	2	2	N
Binney Street WB TH		5	4	N	3	3	N
Binney Street WB TH/RT		5	5	N	4	4	N
Third Street NB LT/TH		3	4	N	5	5	N
Third Street NB RT		2	2	N	3	3	N
Third Street SB LT/TH/RT	8	8	N	5	5	N	
<i>Broadway at Third Street:</i>	7						
Broadway EB LT		4	4	N	5	5	N
Broadway EB TH		4	3	N	6	6	N
Broadway EB TH/RT		1	1	N	3	3	N
Broadway WB TH		8	8	N	5	5	N
Broadway WB RT		4	5	N	2	2	N
Third Street SB LT/TH		6	6	N	6	5	N
Third Street SB RT	3	3	N	2	1	N	



5. Pedestrian and Bicycle Facilities (for Critical Pedestrian Crossing)

Pedestrian LOS

Intersection	Weekday Morning Peak Hour			Weekday Evening Peak Hour		
	Modified Baseline PLOS	With Project	Exceeds Criteria?	Modified Baseline PLOS	With Project	Exceeds Criteria?
O'Brien Highway at Museum Way: Crossing O'Brien Highway (East) Crossing O'Brien Highway (West) Crossing Museum Way (North)	D D D	D D D	N N N	D D D	D D D	N N N
O'Brien Highway at Land Boulevard/Charlestown Avenue: Crossing O'Brien Highway (West) Crossing Land Boulevard (South)	D E	D E	N Y	D D	D D	N N
O'Brien Highway at Cambridge Street/East Street: Crossing O'Brien Highway (East) Crossing O'Brien Highway (West) Crossing East Street (North)	C C C	C C C	N N N	C C C	C C C	N N N
Cambridge Street at First Street/Bus Station Driveway: Crossing Cambridge Street (East) Crossing Cambridge Street (West) Crossing First Street (South)	C C C	C C C	N N N	C C C	C C C	N N N
O'Brien Highway at Third Street: Crossing O'Brien Highway (East) Crossing Third Street (South)	C C	C C	N N	C C	C C	N N
Cambridge Street at Third Street: Crossing Cambridge Street (East) Crossing Cambridge Street (West) Crossing Third Street (North) Crossing Third Street (South)	B B B B	B B B B	N N N N	B B B B	B B B B	N N N N
First Street at Thorndike Street: Crossing Thorndike Street (West) Crossing First Street (North) Crossing First Street (South)	C C C	C C C	N N N	C C C	C C C	N N N
First Street at Spring Street/Upper Garage: Crossing Spring Street (West)	B	C	Y	A	A	N



Intersection	Weekday Morning Peak Hour			Weekday Evening Peak Hour		
	Modified Baseline PLOS	With Project	Exceeds Criteria?	Modified Baseline PLOS	With Project	Exceeds Criteria?
First Street at Charles Street/Cambridgeside Place: Crossing Cambridgeside Place (East) Crossing Charles Street (West) Crossing First Street (North) Crossing First Street (South)	B B B B	B B B B	N N N N	B B B B	B B B B	N N N N
Cambridgeside Place at Mid-Block Crossing: Crossing Cambridgeside Place	D	D	N	F	F	Y
Land Boulevard at Cambridgeside Place and Hotel Driveway: Crossing Cambridgeside Place (West) Crossing Land Boulevard (North)	D D	D D	N N	D D	D D	N N
Land Boulevard at Binney Street: Crossing Binney Street (West) Crossing Land Boulevard (North) Crossing Land Boulevard (South)	E E E	E E E	Y Y Y	E E E	E E E	Y Y Y
Binney Street at First Street: Crossing Binney Street (East) Crossing Binney Street (West) Crossing First Street (North) Crossing First Street (South)	D D D D	D D D D	N N N N	D D D D	D D D D	N N N N
Binney Street at Second Street: Crossing Binney Street (East) Crossing Binney Street (West) Crossing Second Street (North) Crossing Second Street (South)	D D B B	D D B B	N N N N	D D B B	D D B B	N N N N
Binney Street at Third Street: Crossing Binney Street (East) Crossing Binney Street (West) Crossing Third Street (North) Crossing Third Street (South)	B B B B	B B B B	N N N N	B B B B	B B B B	N N N N
Broadway at Third Street: Crossing Broadway (East) Crossing Broadway (West) Crossing Third Street (North)	C C C	C C C	N N N	C C C	C C C	N N N



Safe Pedestrian and Bicycle Facilities

Adjacent Street or Public Right-of-Way	Sidewalks or Walkways Present?	Exceeds Criteria?	Bicycle Facilities or Right-of-Ways Present?	Exceeds Criteria?
Cambridgeside Place	Y	N	N	Y
Land Boulevard	Y	N	N	Y
First Street	Y	N	Y	N

