

# Alewife District Plan

A report of the Alewife Planning Study  
Fall 2019



## Alewife District Plan

Prepared for the City of Cambridge Community Development Department, 2019. See Acknowledgments on page 166 for a complete list of those who contributed to or otherwise helped craft this document.

## Executive Office

Louis A. DePasquale, City Manager  
Lisa C. Peterson, Deputy City Manager

## City Council

Marc C. McGovern, Mayor  
Jan Devereux, Vice Mayor  
Dennis J. Carlone  
Craig A. Kelley  
Alanna M. Mallon  
Sumbul Siddiqui  
E. Denise Simmons  
Timothy J. Toomey, Jr.  
Quinton Y. Zondervan

## Planning Board

Catherine Preston Connolly, Chair  
H. Theodore Cohen, Vice Chair  
Louis J. Bacci, Jr.  
Nikolas Bowie  
Steven A. Cohen  
Corinne Espinoza  
Mary T. Flynn  
Hugh Russell  
Tom Sieniewicz

**4 Executive Summary**

**12 Introduction**

14 Context

26 Process

**34 Existing Conditions**

34 Urban Form

48 Mobility

60 Climate & Environment

70 Housing

76 Economy

82 Community Wellbeing

**90 Vision and Goals**

**96 Recommendations**

102 Land Use

108 Open Space

114 Urban Form

124 Mobility

134 Climate and Environment

144 Housing

148 Economy

154 Zoning

**166 Acknowledgments**

# Executive Summary

The Alewife District Plan envisions Alewife as a vibrant mixed-use district with a strong sense of place. Development will promote economic opportunity through the creation of good-paying, low barrier-to-entry jobs, and create additional housing, including affordable housing. New open spaces, local retail, and public amenities will promote walkability and increase opportunities for social connection. Alewife will be resilient to future climate change impacts and encourage sustainable modes of transportation.

## Why plan for Alewife?

Alewife is undergoing rapid change and faces unique environmental, mobility, and infrastructure challenges. This plan aims to set a vision for future development to transform the district into a fully functioning urban neighborhood and advance citywide goals, including economic opportunity, climate change resilience, and walkability.

Historically a low-lying marshland between several bodies of water, the Alewife area developed as a commercial and industrial district in the 19th century. Those development patterns are still reflected in Alewife today in its land uses, urban form, and ongoing environmental challenges. In the 20th century, parkways constructed through the area and the extension of the MBTA Red Line turned the district into a prominent part of the regional transportation system. In more recent years, the development of new residential buildings in historically industrial and commercial areas has signaled a shift toward the mixed-use vision for the district.

Alewife holds a unique position in Cambridge's economy as one of the few remaining places with industrial

businesses. These businesses provide crucial support to the broader Cambridge economy as well as opportunities for good jobs at a range of skill levels. While much of Alewife retains its light industrial character today, industrial uses would be replaced by office and residential development if the present development trajectory continues.

Alewife also faces many environmental and infrastructure challenges that necessitate coordinated planning, especially to prepare the district for impacts related to climate change. Like other filled lands in the Boston metropolitan region, Alewife is particularly vulnerable to flooding, both from heavy rainfall and coastal surges. Additionally, the district's historical development pattern has led to a very high proportion of paved area and minimal tree cover. This pattern exacerbates flooding and heat island effect from high temperatures, both of which are predicted to occur more frequently in the future. Redevelopment in the district is key to improving environmental quality and ensuring safety during extreme weather events. This will require careful planning to protect critical infrastructure and private property without negatively impacting the public realm.



## Community Vision

Alewife is a sustainable, resilient, mixed-used district with convenient and safe connections within the neighborhood and to the rest of the city along with amenities that support interaction and social ties among its residents.

- Alewife
- Cambridge City Line
- Study Area

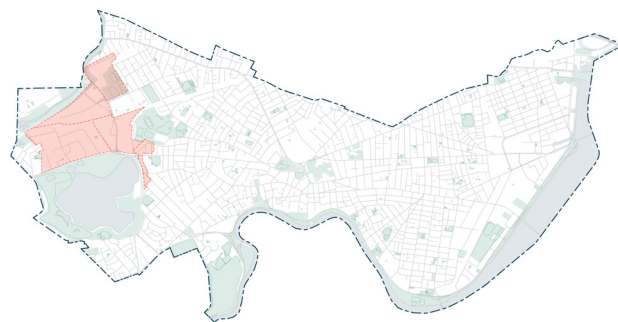

All of these factors contribute to the need for a detailed focus on Alewife. This plan includes recommendations on a range of topics, including land use, urban form, open space, mobility, climate and environment, housing, and economy. These recommendations are informed by the unique development and planning history of Alewife, the district’s existing conditions, and the community’s shared vision for the future.

## Process

The planning process involved extensive data analysis, community engagement, and land use scenario testing that compared alternative future for the district.

Community input was proactively sought at all stages of the planning process and through

a variety of methods. The planning process included 16 Alewife Working Group meetings, four public workshops, six focus groups, a youth workshop, fifteen street team events, and online and in-person surveys.

The land use scenario analysis compared alternative futures for Alewife. The analysis explored redevelopment of the Alewife Quadrangle in detail by comparing land use, density, building types, and the street network, and assessing the quantitative and qualitative effects of these scenarios on housing, jobs, mobility, the environment, and municipal finances. Public feedback on these scenarios guided the development of this plan. Through this multifaceted process, the community developed a vision for the future of the Alewife district and a set of comprehensive and actionable recommendations.



Public workshops for the Alewife Planning Study were held at local community spaces like the Tobin School (May 2018).



The street team traveled across the city to get public feedback on the plan.

## Existing Conditions

Extensive analysis of existing conditions informed the planning process, helping to frame both the challenges and opportunities facing the Alewife district.

### Urban Form

In general, Alewife has a highly varied urban form. The district is notable for low-density development, often suburban in character. Some of the city's most significant open space resources, including Fresh Pond Reservation and Danehy Park, are in close proximity to Alewife, but there is a lack of connectivity between these resources and the surrounding neighborhood.

### Mobility

Moving within and through Alewife is very difficult. Heavy regional traffic on the parkways spills into the surrounding area and acts as a barrier

for travel between different parts of the district and the rest of Cambridge. The street network is sparse and disconnected, making biking and walking inconvenient and restricting access to transit. In a pattern unseen elsewhere in the city, the majority of residents around Alewife commute to work by car and the majority of visitors to Alewife use a car to get there.

### Climate and Environment

Alewife is one of the most vulnerable areas of the city to the impacts of climate change. More frequent flooding will be exacerbated in Alewife due to its low elevation and vast impervious surface coverage. Increasing temperatures and heat waves will be felt more intensely due to Alewife's lack of tree canopy. Sea-level rise and storm surge (SLR/SS) may produce widespread flooding in the district; however, the more immediate and predictable threats are increasing and extended precipitation events and heat waves.

Additional environmental challenges include mitigating excess stormwater runoff due to a high water table and dense soils; remediating areas of contaminated land; improving degraded air quality due to auto-emissions; and monitoring water quality at Alewife Brook.

### Housing

Residential development in Alewife has grown dramatically in the past decade despite its historical role as an industrial and commercial district. New housing is typically in large market-rate apartment buildings, with affordable units provided through the City’s Inclusionary Housing Program. Peripheral to the center of the Alewife district, the area’s housing stock is comprised of two- to three-family homes, single-family residences, and apartment buildings, consistent with Cambridge’s residential architectural character.

### Economy

Alewife is a critical part of the economy, both for Cambridge and for the wider region. The district provides lower-cost space for innovation-based businesses and new firms, particularly in the life sciences industry. These firms have fueled Cambridge’s economic growth in recent decades. Furthermore, Alewife is one of the last parts of Cambridge that currently supports light manufacturing. Alewife could continue to play an important role as a generator of economic diversity and source of equitable employment opportunities for residents.

### Community Wellbeing

The population of Alewife and adjacent communities is more racially diverse than Cambridge overall, with a larger proportion of families and



Small groups at the Alewife Visioning Workshop, one of four public meetings, provided ideas for the future of Alewife (July 2016).



a mix of ages. According to US Census 2015 American Community Survey data, the greater Alewife area has fewer residents with high educational attainment and a larger proportion of people who earn less than \$25,000 compared to Cambridge as a whole. Alewife's demographics are likely changing as new development brings new residents, who will be accounted for in the 2020 Census.

---

## Vision and Goals

The community crafted a shared vision for Alewife that prioritizes economic opportunity, connectivity, resilience, and social cohesion. To support this vision, the community developed the following areawide goals

### Build a Cohesive Mixed-Use District.

Transform Alewife into a fully functioning urban neighborhood with a broad range of uses and a variety of public places that provide opportunities for social cohesion.

### Integrate Alewife with the Rest of Cambridge.

Better integrate the district physically and socially with the surrounding neighborhoods and the rest of the city to promote a greater sense of community.

### Promote Economic Opportunity

Support commercial and light industrial development that provide high-wage, low barrier-to-entry jobs.

### Create a District Resilient to the Impacts of Climate Change.

Ensure that new development and existing neighborhoods, community resources, and critical infrastructure are prepared for climate change and resilient to its impacts.

### Enhance the Public Realm

Create an active, resilient urban form that promotes activity on the street.

### Encourage Sustainable Modes of Transportation.

Promote walking, biking, and transit use and reduce the growth in vehicle miles traveled.

### Create a Continuous Open Space & Recreation Network.

Increase the quantity, quality, and diversity of open spaces across the Alewife district and create an interconnected recreation network.

## Recommendations

### Land Use

The plan proposes a balanced mix of uses. The preservation of light-industrial businesses compatible with an urban mixed-use district will add to Alewife's character and job diversity. By blending development types and uses and drawing new populations of residents and workers, Alewife will become a more dynamic, interesting, and liveable neighborhood.

### Open Space

The plan recommends a network of high-quality open spaces of varying size and character. An expanded open space network of streets, parks, and squares will improve connectivity across and within the district; reduce heat and flooding impacts; provide alternatives to car travel; and increase health and wellness of residents and workers. A proposed 3-acre linear open space in the Quadrangle and a public square in the Shopping Center will serve as central gathering spaces for the community.

### Urban Form

The plan includes urban design approaches that aim to promote the area's transition to a more pedestrian-friendly, mixed-use environment while still protecting against future flooding and heat impacts. These strategies include elevating buildings while maintaining a pedestrian-accessible ground floor using elevated walkways, as well as continuous tree plantings along street frontages and more contiguous planted open space in the interiors of blocks. Design guidelines were created to guide future development and help define the built character of the district.

### Mobility

The plan identifies strategies to improve connectivity, promote sustainable modes of transportation, and reduce dependency on automobile travel. Specifically, the plan recommends progressive transportation policies such as low parking maximums and enhanced parking and transportation demand management, as well as new streets and

bicycle and pedestrian infrastructure. Additional recommendations include improved MBTA bus service and expanded shuttle service to and from the Alewife MBTA Red Line Station.

### Climate and Environment

In order to achieve a sustainable, resilient future, the plan incorporates climate change mitigation and resilience strategies. Recommendations include strategies for mitigating and adapting to more frequent flooding and increased temperatures. The Climate Change Preparedness and Resilience (CCPR) Plan for Alewife serves as the foundation for several of the recommendations in this plan. Additional climate and environment recommendations include on-site energy generation, energy efficiency measures, tree plantings, and green infrastructure.

### Housing

Housing recommendations for Alewife support a larger citywide goal to increase overall housing supply in Cambridge, including a significant amount of new affordable housing. The plan identifies the Quadrangle and the Shopping Center as significant growth areas for new housing units. A variety of housing types at different levels of affordability will create a diverse community.

### Economy

The plan prioritizes the creation of a light industrial district within a portion of the Quadrangle to preserve and expand the types of businesses that currently call Alewife home. Legacy businesses, such as Iggy's Bread of the World, Gymnastics Academy of Boston, Central Rock Gym, Longleaf Lumber, and Anderson McQuaid, serve vital community functions, including unique products and retail experiences, important amenities for Cambridge residents, community gathering spaces, and good paying, low barrier-to-entry jobs, or jobs with minimal educational requirements. This plan includes recommendations to retain Alewife as a diverse jobs center while transforming it into a walkable, urban center.



# Introduction





# Context

**A**lewife is undergoing rapid change and faces unique environmental, mobility, and infrastructure challenges. Its current condition – and potential for change – necessitate a forward-thinking plan. This chapter describes how Alewife’s past land uses and planning efforts contribute to present day conditions. This historic context serves as an important foundation to understand key issues and opportunities facing the district and create an effective plan.

Learn more about...

“Why Focus on Alewife?” on page 18

“Historical Development” on page 21

“Past Planning Efforts” on page 22

“Study Area” on page 24

“Alewife Subdistricts” on page 24





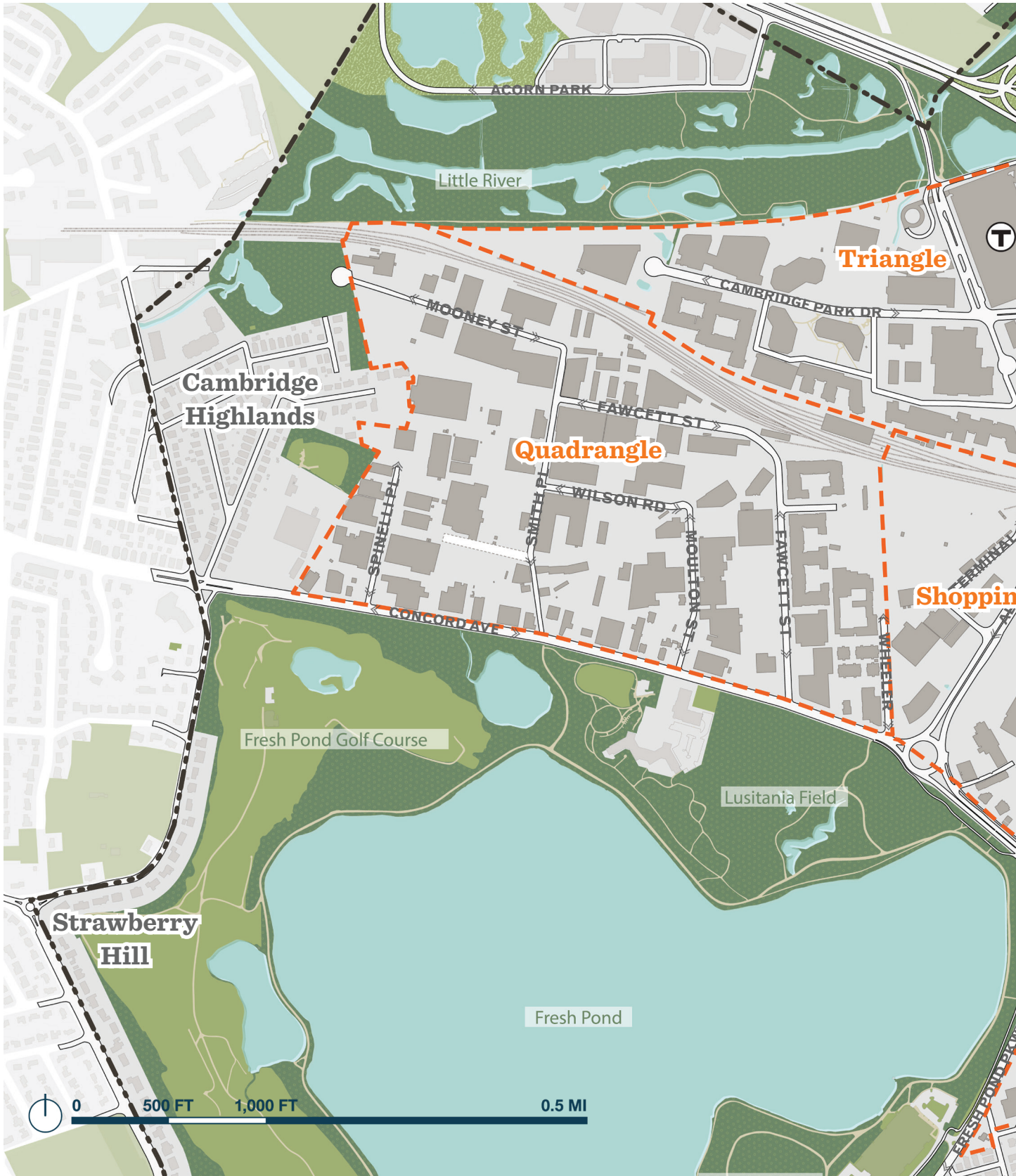





**Alewife**

- Cambridge City Line
- - - Study Area



## Why focus on Alewife?

Historically a low-lying marshland between several bodies of water, the Alewife area developed as a commercial and industrial district in the 19th century. Those development patterns are still reflected in Alewife today in its land uses, urban form, and ongoing environmental challenges.

Through a combination of urban planning processes and a boom in the Cambridge real estate market, Alewife became a locus for development in the city. In the 20th century, Alewife became prominent in the regional transportation system: parkways were constructed through the area, and the MBTA Red Line was extended to Alewife. Plans from the last several decades have called for its redevelopment into a mixed-use district and a destination within the city. In more recent years, the development of new residential buildings in historically industrial and commercial parts of the district signaled a shift toward the mixed-use vision for the district envisioned in the most recent 2005 Concord-Alewife Plan.

Despite the visible increase in residential development, Alewife continues to occupy a unique position in Cambridge’s economy as one of the few remaining places in the city industrial

businesses. These businesses provide crucial functions to the broader Cambridge economy and opportunities for good jobs at a range of skill levels.

Alewife also faces many environmental and infrastructure challenges, especially those related to climate change. Like other filled lands in the Boston metropolitan region, Alewife is particularly vulnerable to flooding, both from heavy rainfall and sea level rise. In addition, the district’s historical development pattern has led to a very high proportion of paved area and minimal tree cover. This pattern exacerbates flooding and heat impacts, both of which are predicted to occur more frequently in the future. Redevelopment in the district is key to improving environmental quality. Careful planning is necessary to ensure safety during extreme weather events and protect critical infrastructure and private property, without negatively impacting the public realm.

This confluence of factors creates the need for a more detailed focus on Alewife within the context of the Envision Cambridge citywide plan.

Large-Scale Development in Alewife by Year Completed, 1997-2015, and Relevant Regulations

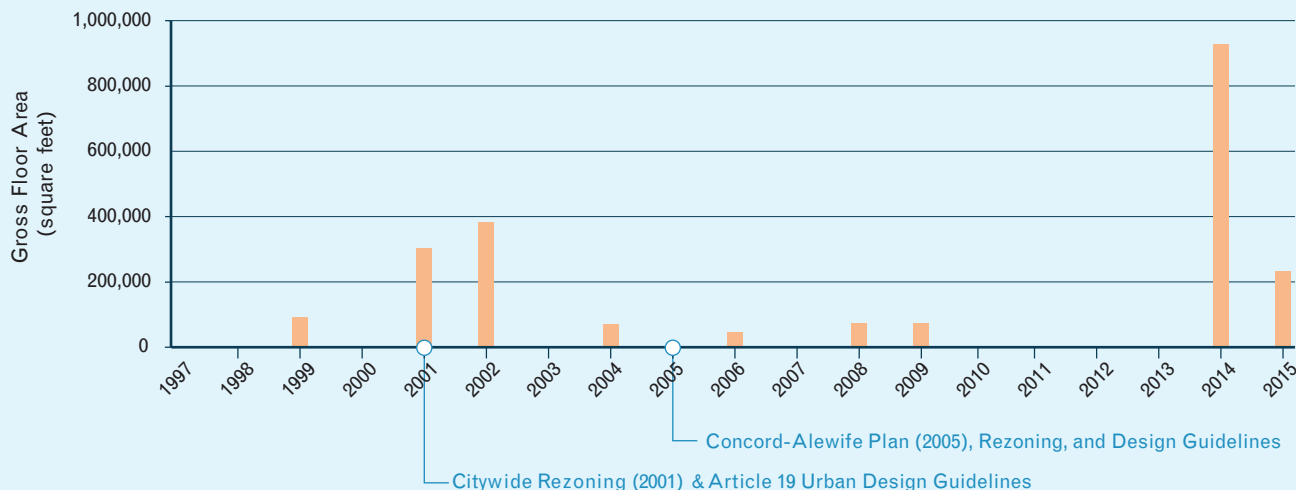

Source: City of Cambridge Development Log, 1997-2015



Alewife's industrial and suburban urban form is different than the rest of Cambridge.



Due to a boom in the Cambridge real estate market, Alewife has become a locus for development in recent years.



Alewife's parkways have faced heavy traffic for nearly half a century.



Aerial view of Alewife from the southwest, 1947.

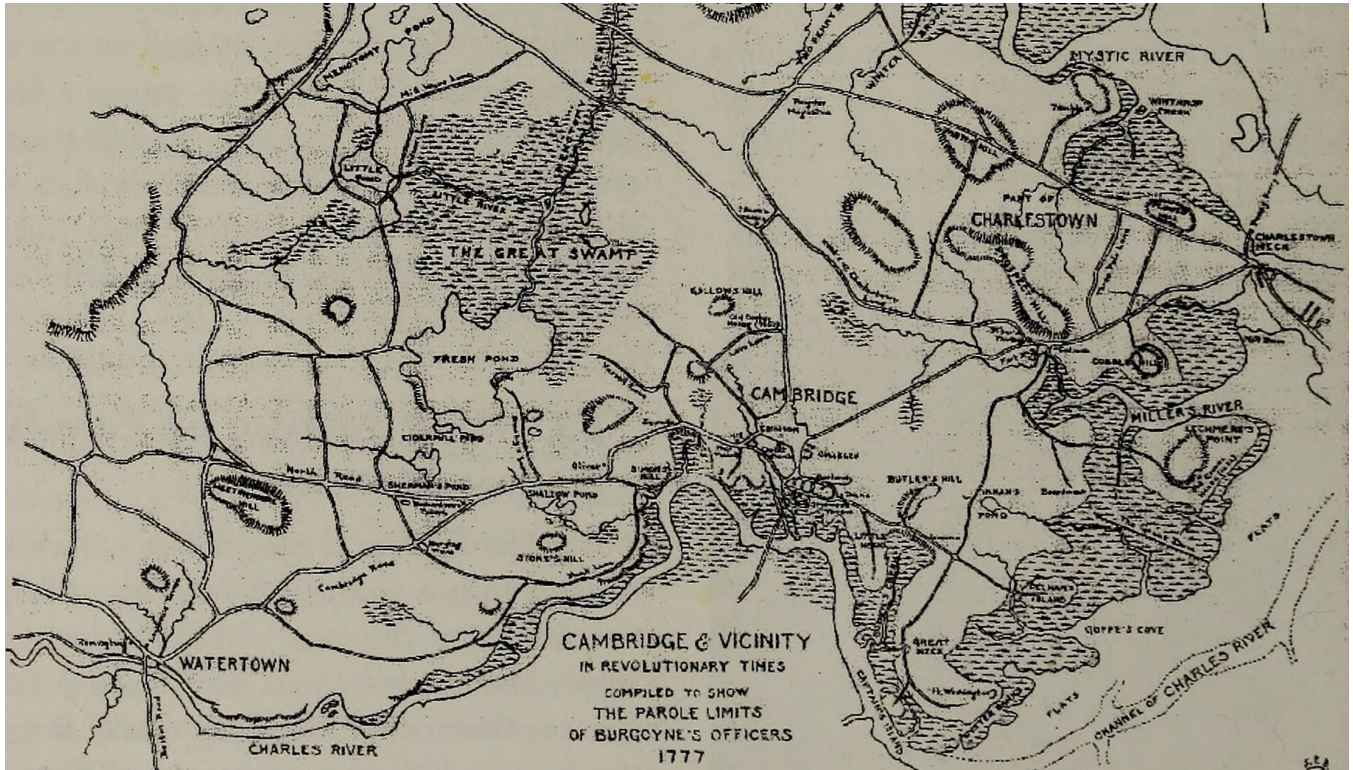

Alewife is marked as “The Great Swamp” on this 1777 map.

## Historical Development

Alewife has served as a valuable industrial and commercial center in Cambridge for more than a century, and much of its present-day urban form can be traced to this past. Prior to the 1800s, Alewife existed as marshes and swampland originally inhabited by the Pawtuckeog tribe. The area offered an abundance of fish and game, well-connected waterways, and fertile soil for agriculture. In fact, the name “Alewife” comes from the alewife fish that was prevalent in the area. In the 19th century, the area’s proximity to Boston and ample land attracted ice and brick manufacturers, cattle yards, slaughterhouses, tanneries, rail yards, and other industrial uses.

By 1841, the first railroad linking Alewife to West Cambridge was put in place, connecting Fresh Pond to national and international trade routes. The first modern industry to arrive in

Alewife was Penn Metal, a steel fabricator that opened in the Quadrangle in 1910.<sup>1</sup> The next wave of Alewife’s expansion in the 20th century gradually converted exhausted clay pits and brickyards into urban fringe activities such as factories and dumps.<sup>2</sup>

During the Great Depression, Alewife’s parkways and infrastructure were upgraded through public works projects. Lured by its location, regional transportation network, and low cost of land, businesses continued to locate in Alewife throughout the 20th century and up to the present, although the types of businesses changed over time. Alewife remains an important employment center in Cambridge, and with the growth of residential development following the planning and rezoning in 2005, it is transforming into a mixed-use neighborhood for people to live, work, play, and shop.

<sup>1</sup> Howard, Jerry. “A Brief People’s History of Alewife” *North Cambridge News*, June 1995.

<sup>2</sup> Cambridge Historical Commission, 2000, [cambridgema.gov/~media/Files/historicalcommission/pdf/markers\\_NC\\_jerryspit.pdf?1a=en](http://cambridgema.gov/~media/Files/historicalcommission/pdf/markers_NC_jerryspit.pdf?1a=en).

## Past Planning Efforts

Alewife has been the subject of a number of district-wide planning efforts over the years. Like the present plan for Alewife, these plans addressed issues specific to the district, while aligning with the priorities set forward in city-wide planning efforts. The following section summarizes the main points from some of the past and present plans that inform this plan.

### Alewife Revitalization Plan, 1979

This plan included recommendations to revitalize the declining industrial area. Key recommendations included:

- Transform the primarily industrial area into a new center for research and development, creating job opportunities and increasing the city's tax base, while removing ecological hazards.
- Prioritize higher-value commercial uses over residential and industrial uses.
- Create a new open space, centered on a canal running south from Alewife Brook.
- Improve the urban form of the district and buffer residential neighborhoods and nearby public open spaces from new development.
- Connect the Triangle and Quadrangle through the creation of "Alewife Boulevard," an internal access road that provides bicycle and pedestrian links across the district.

### Alewife Plan for Sustainable Development, 1995

This plan identified area-wide recommendations in support of the City's growth policy document, *Toward a Sustainable Future*. Key recommendations included:

- Improve transportation by creating more usable vehicular connections, promoting public transportation through additional bus lanes, adding bicycle and pedestrian facilities and amenities, and encouraging employer-implemented vehicle trip reduction strategies.
- Create new parks and open space using public funding, private incentives, and zoning.
- Establish urban design overlay districts with design guidelines aimed at creating a sense of place.

### Fresh Pond Reservation Master Plan, 2000

Completed in 2000, this master plan established a framework for the preservation of water quality, recreational open spaces, natural green spaces, and wildlife habitats at Fresh Pond. Key recommendations included:

- Adopt and implement ecological resource management and maintenance policies.
- Establish resource usage policies that balance public enjoyment with protection of the city's water supply.
- Implement a land use policy that prioritizes open space within the Reservation.

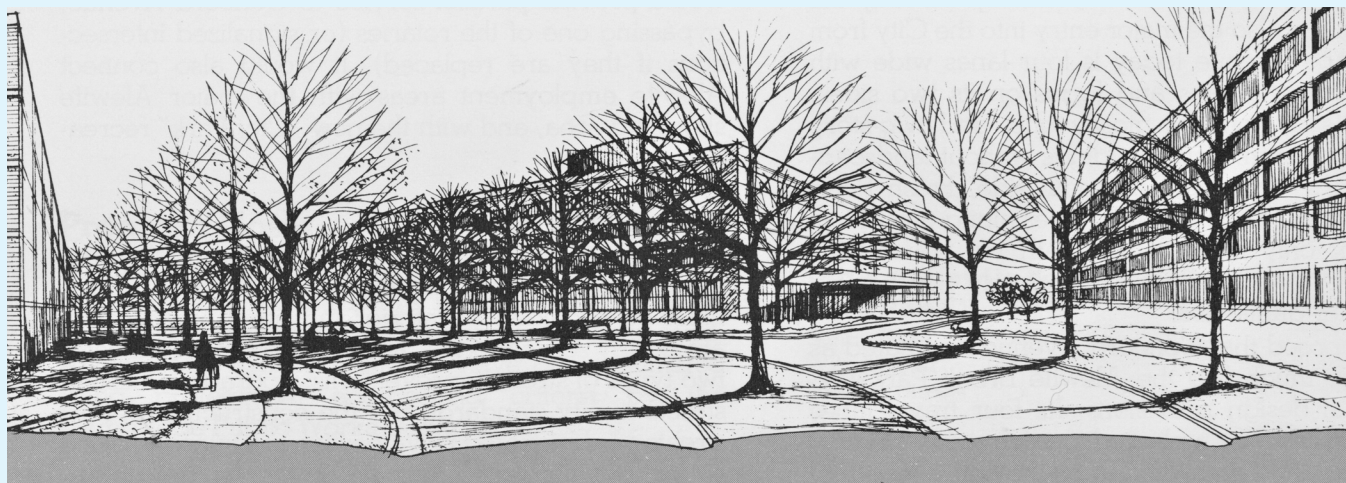

The Alewife Revitalization Plan (1979) proposed a new public space for Alewife along a canal running south from Alewife Brook.

- Increase staff capacity at the Water Department to implement the plan.

### **Alewife Reservation and Alewife Brook Master Plan, 2003**

This plan was commissioned by the Metropolitan District Commission, now the Massachusetts Department of Conservation and Recreation (DCR), which owns the majority of the green space located in Alewife, including the Alewife Reservation. Key recommendations included:

- Utilize strategies to improve water quality and natural hydrology, protect and enhance wildlife habitat, and promote recreational, cultural, and educational opportunities.
- Construct bridges, bike paths, trail networks, viewing platforms, and educational features.
- Conduct invasive species removal programs, biofiltration, and stabilization of eroding stream banks.

### **Concord-Alewife Planning Study, 2005**

The Concord-Alewife Planning Study created a vision for a people-oriented Alewife, developing a neighborhood “heart” for people who live, work, play, and shop. The study followed the 2001 *Plan for Citywide Growth*, which identified Alewife as an area with significant development opportunity. Key recommendations included:

- Promote mixed-use and higher density development closer to Alewife Station, with incentives for residential development.
- Leverage development to create infrastructure improvements such as new streets and pedestrian/bike connections including a bridge across the railroad tracks.
- Create open space and permeability requirements to encourage low-impact development strategies to enhance stormwater retention and quality.
- Adopt a transfer-of-development rights provision to protect the Cambridge Highlands while allowing new development.

### **Alewife Transportation Update, 2014**

An update of the Concord-Alewife Planning

Study, the Alewife Transportation Update illustrated the transportation challenges within the district and provided an update on how the transportation elements of the Concord-Alewife Plan were being implemented. Key findings included:

- The presence of inadequate pedestrian and bicycle connections, and a lack of connectivity within the district and to the rest of the city.
- A significant number of residential projects were completed in the decade subsequent to the Concord-Alewife Plan.
- A considerable portion of the traffic in Alewife has neither an origin nor a destination there; according to the update, 82% of vehicle traffic in Alewife is generated by through-trips.

### **Climate Change Vulnerability Assessment (CCVA) Report, 2015**

The CCVA identified municipal vulnerabilities in relation to future climate change. The report served as the technical foundation for the subsequent Alewife Climate Change Preparedness and Resilience Plan (2017). Key findings included:

- Cambridge is at risk to face triple the number of days over 90 degrees by 2030, and four to six times more days over 90 degrees by 2070.
- Precipitation-driven flooding could expand in extent and depth in the future.
- Key infrastructure such as electrical substations, transit stations and rail lines, telecommunications equipment, and other critical facilities could face new and exacerbated risks.
- Alewife is one of the most vulnerable areas in Cambridge with regard to climate change-related flooding and extreme heat.

### **Climate Change Preparedness and Resilience (CCPR): Alewife Preparedness Plan and Handbook, 2017**

CCPR is a plan for a prepared and resilient Cambridge. It includes citywide and Alewife-specific recommendations to prepare for climate change impacts. CCPR recommendations were incorporated into the Alewife District Plan.

## Study Area

The Alewife study area encompasses roughly 300 acres, stretching from the Alewife Reservation in the north to the Fresh Pond Reservation in the south, and from the Cambridge Highlands neighborhood in the west to Danehy Park in the east. The study area abuts the Belmont and Arlington town lines, which serve as a main point of entry into Cambridge.

Alewife has a mixed pattern of development, with new development taking place in certain areas but not others. The study area includes a number of recently planned and permitted projects. These parcels are unlikely to change significantly in the short- to medium-term. The plan takes into account the current development pipeline and focuses on the areas within the Alewife district that are most likely to see significant change.

## Alewife Subdistricts

Drawing on past planning efforts in Alewife, this plan divides the study area into five subdistricts, each of which has a distinct development character and urban form. Together, these subdistricts encompass the unique fabric that exemplifies Alewife.

### Quadrangle

The Quadrangle is the largest subdistrict in Alewife. It is also the one with the greatest number of parcels with a high likelihood for redevelopment in the next 15 to 20 years. Based on an analysis of building trends in Alewife, roughly 60% of the total projected development in the Quadrangle may be realized by 2030.<sup>1</sup> Considering that there are 48 different property owners among the 99 parcels within the Quadrangle,<sup>2</sup> coordinated redevelopment may be difficult, as property owners have different intentions, interests, and timelines for redevelopment. Currently, the Quadrangle is dominated by commercial and industrial land uses, with a large amount of impervious surfaces in the form of parking lots and truck loading areas. Fewer than

five parcels contain residential land use; however, the majority of new or permitted development is residential.

### Shopping Center

The Shopping Center subdistrict is dominated by commercial uses. It contains a large concentration of retail, including a Trader Joe's and a Whole Foods Market. Access to these amenities is often challenging due to busy roadways and large surface parking lots. This especially limits access for pedestrians and cyclists who have to navigate an environment designed for automobiles.

### Fresh Pond Parkway

The Fresh Pond Parkway subdistrict consists of the area immediately east of Fresh Pond Parkway, from the intersection of Fresh Pond Parkway and Lexington Street up through the commercial area north of Concord Avenue between New and Fern Streets. Most of the land in this subdistrict is devoted to auto-oriented commercial or institutional uses that take on a suburban character. The subdistrict also includes the Tobin School, a public school offering kindergarten through eighth grade, and the Cambridge Armory, a recreation center and Army National Guard outpost.

### Whittemore Avenue

The Whittemore Avenue subdistrict is an area east of Alewife Brook Parkway extending north from Rindge Avenue up to Whittemore Avenue. Most of the subdistrict is owned by GCP Applied Technologies, a subsidiary of the longstanding chemical conglomerate W.R. Grace and Company. Historically a site for clay mining, Jerry's Pond and surrounding area became a chemical manufacturing and by-product dumping site in the 20th century. Most of this area is fenced off from public access, but it also includes several office buildings along the northern edge of the subdistrict and an entrance to the Alewife MBTA station. In recent years, former industrial sites adjacent to the subdistrict have been developed as low- and mid-density housing. Much of the Whittemore Avenue subdistrict is vulnerable

<sup>1</sup> Community Development Department development log analysis, 2017, subject to revisions based on ongoing analysis.

<sup>2</sup> Cambridge Department of Assessing, 2016, Envision Cambridge analysis.



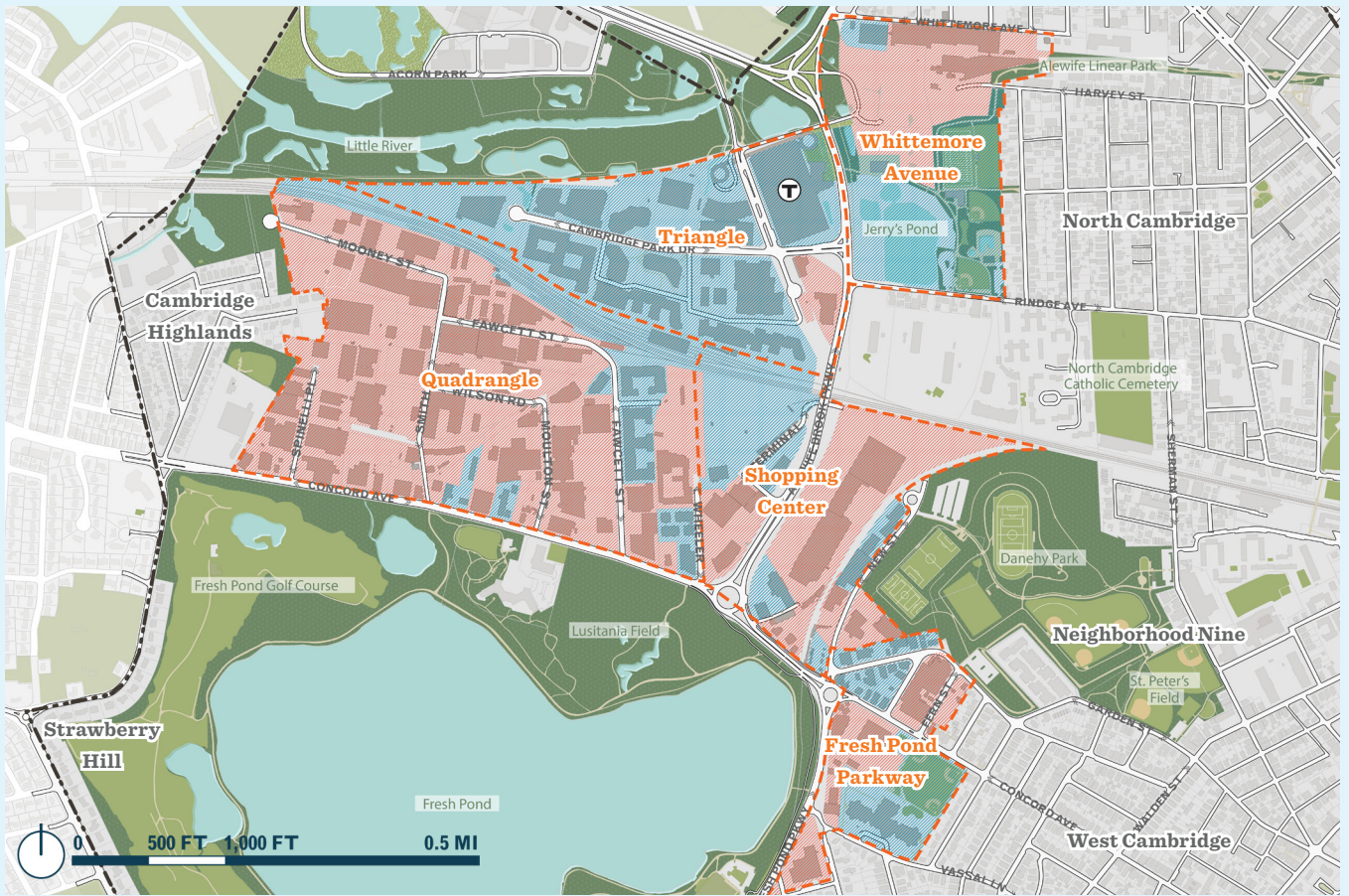

## Potential for Change in Alewife

While Alewife has evolved in recent years, much of it may still change in the future. This plan identifies where opportunities for future transformation may occur.

### Parcel Status

- High Likelihood of Change
- Low Likelihood of Change
- Cambridge City Line
- Study Area

to flooding from large storm events and future storm surges that breach the Amelia Earhart Dam on the Mystic River.

### Triangle

Overall, the Triangle is the most densely and recently developed subdistrict. The area is characterized by a combination of 1980s era office space and more recent residential buildings. The

subdistrict has undergone significant residential redevelopment in the past five years transforming it from an office precinct to an emerging mixed-use district. Due to recent and permitted development, there are limited parcels likely to redevelop by 2030. Thus, this subdistrict was not the focus of this planning study.



# Process

The Alewife Planning Study involved extensive data analysis, community engagement, and scenario testing that compared alternate futures for the district. These components were not separate from one another: community feedback, informed by experience and data, shaped both the development of scenarios and the plan's recommendations. Through a process of iteration and refinement, based on public discussion and feedback, an actionable plan emerged. This chapter presents a detailed look at the planning process.

Learn more about...

“Engagement Approach” on page 28

“Workshops” on page 29

“Focus Groups” on page 29

“Scenarios” on page 31



## Engagement Approach

Community input was proactively sought at all stages of the planning process and through a variety of methods. The planning process included 16 Alewife Working Group meetings, four public workshops, six focus groups, a youth workshop, fifteen City street team events, and four meetings with other committees and neighborhood associations.

The following objectives guided the engagement process:

- Collect deep local knowledge that can serve as a key source of information.
- Gather feedback on important questions for the future.
- Build an understanding among members of the public about the process and the variety of perspectives held by those who care deeply about Alewife.
- Create an engaged community through inclusive and wide-reaching public engagement.
- Develop a shared vision representative of

all community stakeholders that includes priorities for the district's future.

- Create a framework for ongoing outreach, collaboration, and engagement.

Findings from the community engagement process are included throughout the Existing Conditions chapter of this report, covering urban form, mobility, climate and the environment, housing, economy, and community wellbeing. These summaries offer a glimpse into the feedback gathered through a variety of engagement methods, and represent the opinions of residents and employees of Alewife and the greater Cambridge community.

### Alewife Working Group

Comprised of Cambridge residents, representatives of local businesses, and property owners, the Alewife Working Group guided the overall planning process. Over the course of 16 meetings, the Alewife Working Group helped to craft a shared community vision and develop comprehensive and actionable recommendations.



Community members discussed issues in Alewife at interactive public meetings like this one at the Tobin School (March 2016).

### Workshops

Four public workshops were hosted in Alewife to share the planning team’s analysis and gather input from the community. They were designed to be interactive and engaging. The first, a “listening workshop,” asked community members to share their hopes for the district and concerns about its future. At the second, a “visioning workshop,” the community collaborated to generate a shared vision for Alewife. The third workshop invited participants to respond to different future scenarios for the Alewife Quadrangle, each with a different mix of land uses and building densities. The final workshop presented the final plan for feedback.

### Focus Groups

Working with the City’s Community Engagement Team, regular focus groups were held to reach underserved communities, including immigrant and American-born black households. Approximately 40 community members participated in the focus groups and provided input on the plan.

### Street Team

The Envision Cambridge Street Team traveled across the city deploying interactive activities and administering surveys to get public feedback on the plan. It’s main feature was a “Mobile Engagement Station,” a large interactive map of Cambridge that was designed to be fun and engaging. Using the map, the Street Team asked community members to highlight their favorite places in the city and identify improvement areas. During the Alewife planning process, the Mobile Engagement Station was set up nearly 60 times, including 15 times in the Alewife study area.

### Surveys

A survey on the vision for Alewife was distributed online, as well as, in-person by the street team. The survey asked respondents to describe their aspirations for the area and name their top three concerns. Over 250 surveys were collected.



Community members of all ages provided input through the Mobile Engagement Station at Fresh Pond Day (June 2016).



The planning team engaged with residents at Daney Park Family Day.



## Scenario Planning

A key piece of the Alewife Planning Study was the testing of four development scenarios, or structured thought experiments for the future of Alewife. Though the plan addresses Alewife broadly, the scenarios were focused on the Alewife Quadrangle, the area with the greatest remaining development potential. The scenarios were effective tools to help the community discuss trade-offs of different land use options. Results of this process were incorporated into the planning for the district as a whole.

### Scenarios

Through scenario planning, different decisions—about building density and land use, for example—interact to produce different outcomes. Analyzing multiple scenarios allowed the community to better understand the tradeoffs and impacts of potential decisions. This process enabled the public to craft a preferred scenario that best balanced community priorities.

The Alewife scenarios introduced four potential futures for the Quadrangle in 2030 compared to a baseline scenario of what could be built under current zoning. An Optimized Baseline Scenario maintained the density and uses currently permitted, but adjusted the required building setbacks. Mixed-use Residential and Mixed-use Commercial scenarios followed the Optimized Baseline Scenario design principles, but heavily weighted the use to residential or commercial, respectively. Lastly, the Mixed-use Industrial scenario integrated commercial and industrial space as a primary use.

Scenarios were compared to discuss a mix of land uses, traffic impacts, jobs and housing balance, and trade-offs, as they impact built form. They were then assessed using multiple impact metrics, each derived from the use, density and height of new built area under each scenario. Metrics included:

- Net new market-rate and affordable housing units
- Net new jobs by category: office, industrial, retail, or residential-related



Community members participated in a discussion about the impacts of each development scenario (February 2017).

- Net new residents and public school students
- Net fiscal impact
- Net greenhouse gas emissions
- Amount of pervious versus impervious surface
- Net annual energy consumption
- Net solar energy potential
- Net automobile trips generated on Concord Avenue and Alewife Brook Parkway

### Scenario Feedback

The community reviewed the impacts each scenario would have on housing, jobs, mobility, the environment, and municipal finances. Community members identified key concerns, including the need to protect people and buildings from future climate change impacts; the desire for improved mobility; creation of community spaces; and preservation of unique businesses.

Many community members felt that Alewife’s unique businesses and low-barrier-to-entry jobs should be retained, especially since few other places in Cambridge could still accommodate these uses. The community liked the idea of preserving light-industrial businesses while also increasing residential and commercial development.

This resulted in the development of a preferred scenario that combined elements of each scenario. A mix of uses, including light-industrial, commercial, and residential was promoted. The envisioned mixed-use district would provide a variety of jobs and create new housing. Forward-thinking urban design standards would promote walkability and street activity, while planning for future climate change impacts.

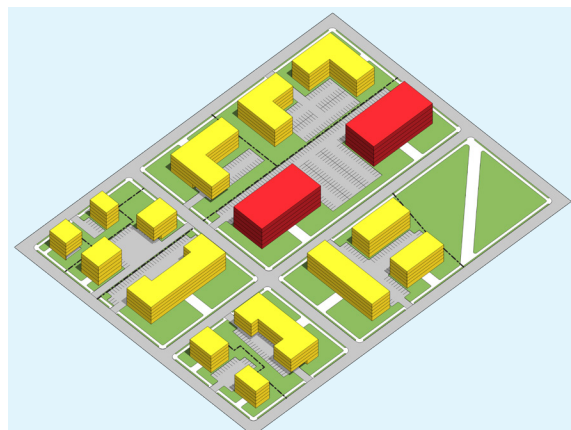

### Baseline

This “no change” condition projected the development likely to occur under existing zoning by 2030. It was used as a baseline for comparison with the other scenarios, which would require changes to current regulation.

- Commercial
- Residential
- Mixed-Use
- Industrial
- Surface Parking





### Scenario 1: Optimized Baseline

The optimized baseline maintained the density and use mix currently allowed under zoning requirements, but altered how development would be arranged on each parcel and how buildings relate to the public realm. Revisions to setbacks allowed building placement along the street front to enhance the urban quality of the space and improve flood resiliency measures.

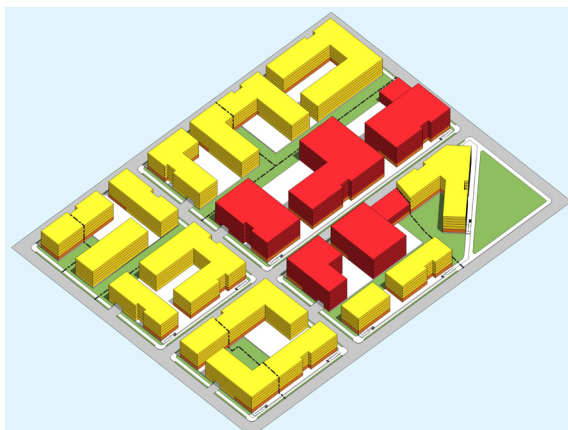

### Scenario 2: Mixed-Use Residential

The Mixed-Use Residential scenario included the same urban design and resiliency approach as the Optimized Baseline scenario, but prioritized residential use over commercial. The average district Floor Area Ratio (FAR)<sup>1</sup> matched the maximum allowed FAR under current zoning requirements.



### Scenario 3: Mixed-Use Commercial

The Mixed-Use Commercial scenario included the same urban design and resiliency approach as the Optimized Baseline, but prioritized commercial over residential uses. The scenario allowed for slightly higher density and yielded a higher average district FAR, similar in scale to Central Square and some other portions of the city.



### Scenario 4: Mixed-Use Light Industrial

While continuing to allow housing, a mixed-use light industrial/commercial development prototype was modeled that included active ground floor space, and office and lab space on the upper floors.

<sup>1</sup> Floor Area Ratio, a measure of development density, is the amount of building area on a site divided by the land area. A FAR of 1 represents a parcel that contains an equal amount of gross area of building space as it does land area. A FAR of 2 means that parcel has twice as much building area as it does land area. FAR says nothing about the arrangement of buildings. For instance, a parcel with an FAR of 2 could contain a 2-story building filling the entire lot, or a 4-story building on half the lot.

# Existing Conditions





# Urban Form

Alewife's urban form is a collection of light industrial buildings, suburban-style shopping centers, late 20th-century office and laboratory buildings, and residences, at a variety of densities throughout the district. Past development patterns responded to certain needs, such as serving high volumes of automobile users and providing production and logistics space for businesses. While new development has produced densities and urban form that are less suburban and more consistent with the rest of Cambridge, the piecemeal nature of new development has yet to change the overall character of Alewife. Meanwhile, the character and density of new developments has often been controversial, with some believing a new approach to district urban design is necessary. As Alewife transforms, the challenge for the district will be to provide a coherent framework for the public spaces that characterize urban environments, making them pleasant places to live, work, and play.

Learn more about . . .

"Property Ownership" on page 38

"Mix of Land Uses" on page 38

"Development Density" on page 41

"Public Realm" on page 42



## Property Ownership

Alewife is comprised of parcels with multiple owners. For example, as of 2016, there are 48 different owners of the 99 parcels that make up the Quadrangle.<sup>1</sup> As the map on the facing page shows, there has been effort toward assembling adjacent parcels, but there remain many small parcels under different ownership. Most land in Alewife is privately-owned, with publicly-owned parcels consisting of parks and natural resources, such as Fresh Pond Reservation and Danehy Park, or public infrastructure like the Alewife MBTA Red Line Station. Given the lack of a single large property owner within the (re)developable parcels, significant transformational development will be challenging.

## Mix of Land Uses

As a transforming industrial and commercial district, Alewife remains home to one of the largest concentrations of commercial land in Cambridge, including laboratory space. The district also has the largest concentration of industrial land left in the city. Together, these commercial and industrial uses comprise nearly half of Alewife’s land.<sup>2</sup> Besides land used for transportation infrastructure and utilities, residential uses are the next most prevalent land use as a result of the 2005 Concord-Alewife Plan, accounting for 10% of the district’s land. Compared to Cambridge as a whole, a small proportion of Alewife’s land is dedicated to streets or sidewalks (10% in Alewife compared to 34% citywide).

### Industrial and commercial uses make up almost half of Alewife’s land area.

Land Uses in Alewife

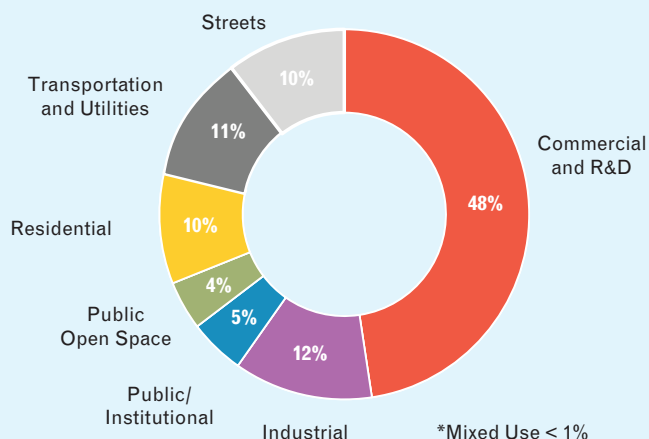

Source: Cambridge Community Development Department (CDD), 2016; Department of Assessing, 2016; Envision Cambridge Analysis. Land uses calculated within the study area boundary, and do not include streets and public spaces adjacent to the study area.

1 City of Cambridge Assessing Department, 2016, Envision Cambridge analysis.

2 City of Cambridge Assessing Department, 2016, Envision Cambridge analysis.

### Property Ownership

Source: City of Cambridge Assessing Department, 2016; MA Secretary of the Commonwealth, 2016

Nearby properties of the same color represent ownership by the same entity.

- Cambridge City Line
- Consolidated Clusters
- ▨ Multi-parcel Ownership
- Single Parcel Ownership

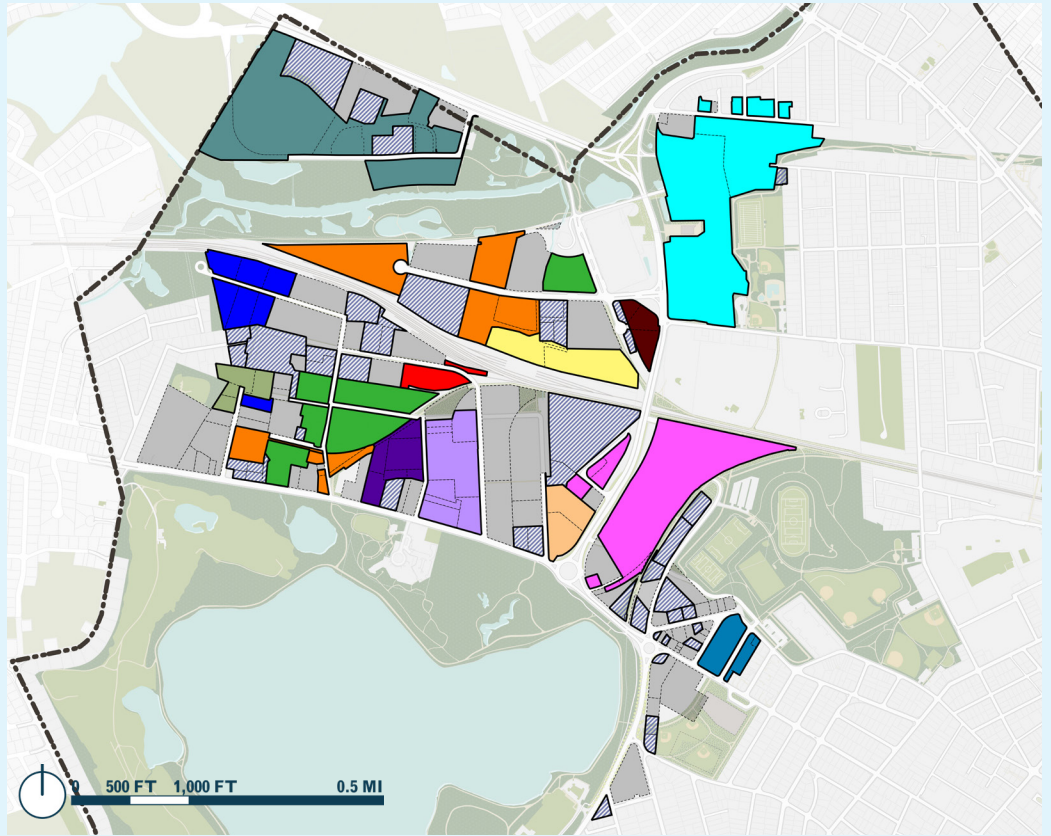

### Building Land Use in Alewife

Source: City of Cambridge Community Development Department, 2016; City of Cambridge Assessing Department, 2016; MassGIS; Envision Cambridge Analysis

- Commercial
- Residential
- Mixed-Use
- Industrial
- Public/Institutional
- Public Open Space
- Parking
- Transportation & Utilities
- Cambridge City Line
- - - Study Area

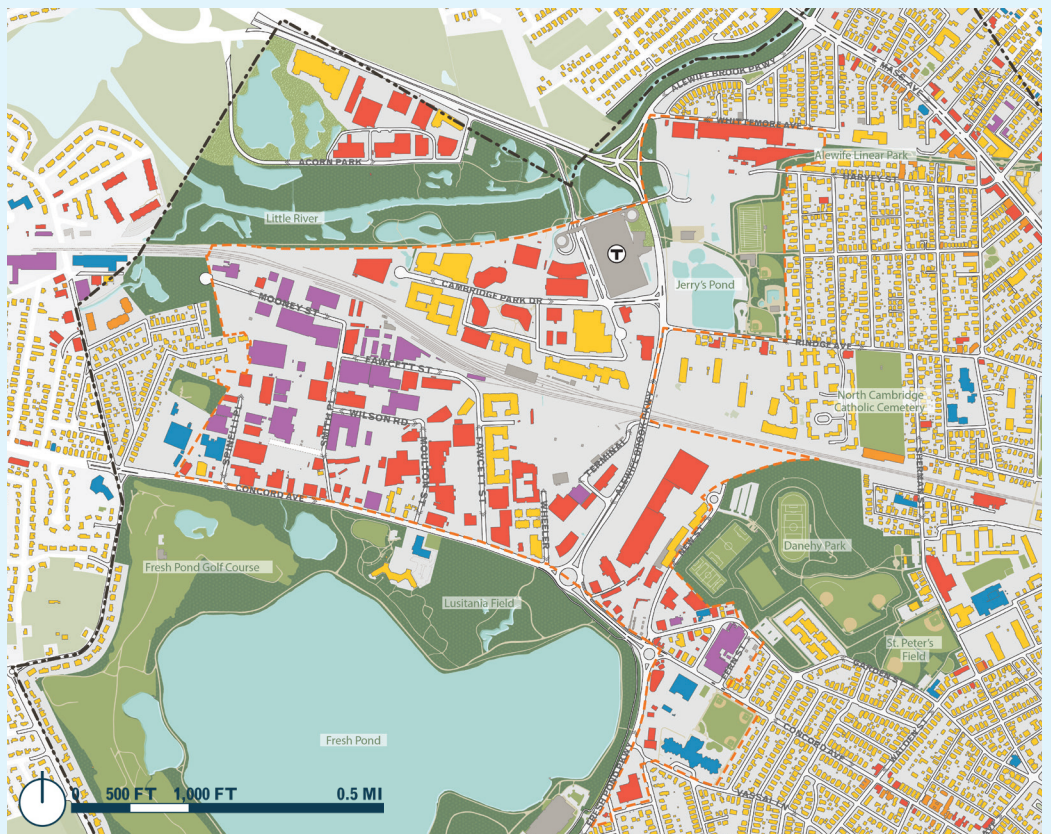

### Building Heights, 2016

Source: City of Cambridge GIS

- 0–44 feet
- 45–54 feet
- 55–69 feet
- 70–84 feet
- 85 or above feet



### Floor Area Ratio (FAR), 2016

Source: Cambridge CDD; Cambridge Department of Assessing; Cambridge Planning Board

- 0–0.75
- 0.76–1
- 1.1–1.25
- 1.26–1.5
- 1.56–1.75
- 1.76–2.0
- 2.1 or above

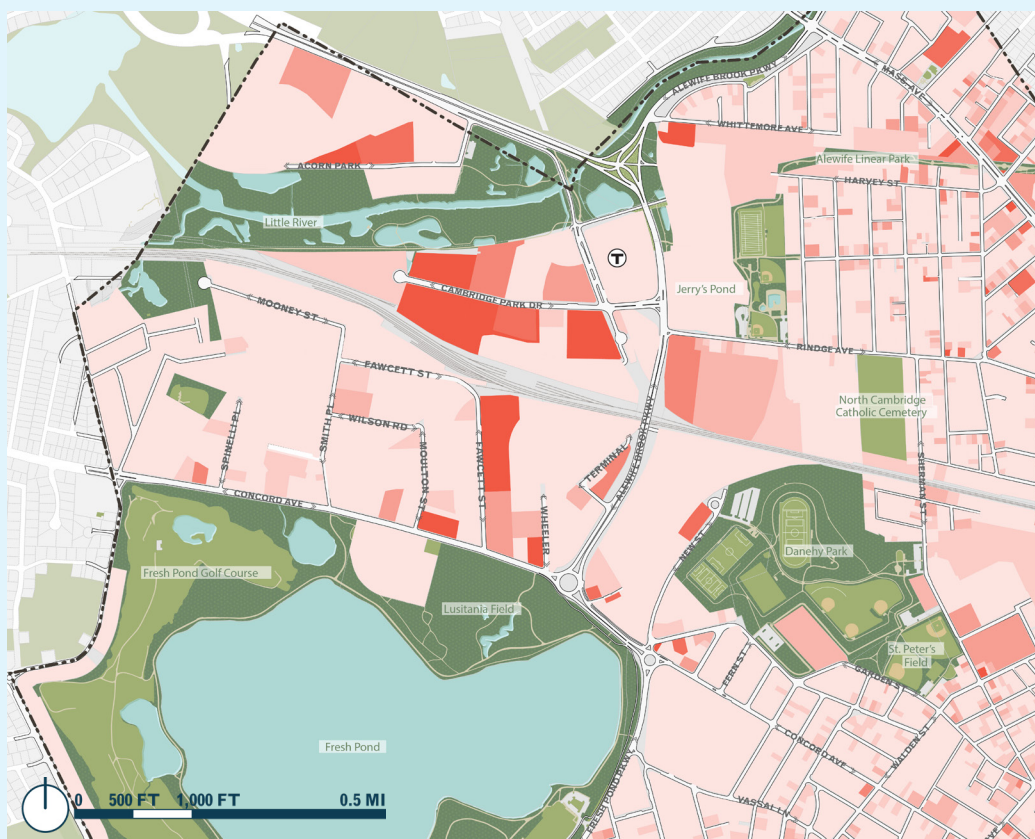





Single-story office and industrial buildings surrounded by parking exemplify the overall low building densities found in Alewife.

## Development Density

Alewife is marked by relatively low development densities when compared to the rest of Cambridge. The average floor area ratio (FAR)<sup>3</sup> of parcels in Alewife is 0.54, much lower than other parts of Cambridge. By comparison, the average FAR for parcels in Harvard Square is 1.81 and the citywide average is 0.86. Similarly, the average building height in Alewife is 22 feet, while the average height in Harvard Square is 40 feet and the citywide average is 26 feet.<sup>4</sup> Alewife's low

building densities and below-average building heights are typical of suburban-style shopping centers and office parks surrounded by large surface parking lots that largely characterized Alewife, although the character has begun to evolve with redevelopment in the past decade. Still, the existing conditions do not provide the sense of enclosure created by a “street wall” and fail to create a legible and meaningful public realm. *Read more about this in “Street Wall: Defining the Public Realm” on page 44.*

<sup>3</sup> Floor area ratio, a measure of development density, is the amount of building area on a site divided by the land area. An FAR of 1 represents a parcel that contains an equal amount of land area as it does gross area of building space. An FAR of 2 means that parcel has twice as much building space as it does land area. Importantly, FAR says nothing about the arrangement of buildings on the parcel. For instance, a parcel with an FAR of 2 could contain a 2-story building filling the entire lot, or a 4-story building on half the lot.

<sup>4</sup> Cambridge Department of Assessing, 2016, Envision Cambridge analysis

## Public Realm

Currently, the public realm in Alewife is dominated by surface parking lots. While surrounded by some of the city’s most significant open space resources, connectivity to these green spaces is poor and not comfortable for pedestrians and cyclists. The district lacks smaller neighborhood-scaled parks that could compensate for the weak connections to nearby larger open spaces and the more traditional streets and public squares found elsewhere in Cambridge.

### Streets and Sidewalks

Streets in Alewife are mainly of two different types: major regional thoroughfares such as Alewife Brook Parkway and Concord Avenue, which are larger and carry more through-traffic than most other streets in Cambridge; and small streets within its subdistricts, which do not connect well to the larger street network. The larger thoroughfares have sidewalks and bicycle accommodations, but crossings are difficult due to the volume and speed of automobile traffic. Particularly in the Quadrangle, existing streets

are little more than driveways or access roads. They often merge imperceptibly with parking lots and lack street elements such as curbs, trees, and sidewalks. They also lack facades that give urban streets spatial legibility, sense of place, and pedestrian comfort. In areas such as the Quadrangle, where development has been piecemeal, sidewalks are not always present and are frequently interrupted by large curb cuts. However, in areas with recent development projects such as the Triangle, sidewalks are generally consistent and of good quality.

### Public Squares

Alewife lacks the public squares that define other parts of Cambridge and support public life. These civic spaces historically developed at the crossings of important streets and are central in the daily lives of Cambridge’s population. Several of these squares, such as Harvard, Central, Porter, Kendall, and Inman, are prominent in the “mental map” people have of the city. The lack of a public square in Alewife further contributes to its lack of a strong sense of place.



Sidewalks are inconsistent in the Alewife Quadrangle, and large building setbacks make the district relatively unfriendly to pedestrians.

## Thoughts from the Community: Urban Form

One goal that echoed throughout the engagement process was to create more inviting and people-centered development. Overall, participants felt that development should be more connected to new and existing open spaces, infrastructure, and amenities. Some identified specific areas that they felt had undesirable urban form, including the shopping center areas adjacent to the parkways; the historic industrial and commercial areas of the Quadrangle; and the new residential and mixed-use development in different parts of the district.

While walkability and pedestrian-scaled development were often the focus of urban form discussions, sustainability and climate change preparedness were major priorities of the community as well. The community offered feedback on the best ways to make Alewife both a welcoming environment and resilient district.



“There should be more consistent restrictions on height and guidelines for architecture in Alewife.”

— Cambridge resident via online survey

“A major goal for Cambridge should be more transit-oriented development, particularly in Alewife and West Cambridge, that takes the form of significantly more density and height, and limited parking.”

— Cambridge resident via online survey

“In the next few decades, I hope Alewife becomes a destination. The area is a vital entry point into and out of Cambridge but is never really considered a destination.”

— Cambridge resident via online survey

**Coherent street walls, with heights proportionate to the widths of streets or open spaces they abut, help define the public realm.**



Buildings in Alewife are often disconnected and set back from the street. Streets without a well-defined street wall can be less enjoyable to walk on.



Buildings in Harvard Square, in contrast to Alewife, touch the front edge of the parcel and buildings on either side, forming a visual street wall. These streets typically have more foot traffic and activity.

**Street Wall: Defining the Public Realm**

A “street wall” consists of a continuous set of building facades aligned with each other and generally consistent in height that frame the street, park, or square they address. The vertical surface of the street wall defines the street as a legible and meaningful public space. Street walls create a feeling of comfort and enclosure, define the public realm and contribute to the vibrancy of an urban area. The design and scale of facades and continuity of the street wall (and in some cases, the activity provided by ground level retail) are important to the quality of the urban pedestrian environment. In contrast, streets where buildings are set back from the sidewalk or where facades of adjoining buildings do not align can feel less pedestrian-friendly.

Streets in Alewife are often set back from the street edge and buildings frequently have unused front and side yards. These patterns result in the lack of a street wall, resulting in a less pleasurable urban experience.

## Resilient Design in the Public Realm

Some climate resilience measures contribute positively to the public realm. For example, the greening of streets through tree planting, green infrastructure, and enhanced open space result in environmental benefits, such as provision of shade, reduction in urban heat island effect, an increase of pervious surface, and additional stormwater storage capacity. These also enhance the public realm by creating a more comfortable environment and spaces conducive to social interaction.

However, in some cases, resilience measures, such as large flood walls, can negatively impact public space and urban form. To avoid this situation, thoughtful design in Alewife can mediate conflicting outcomes and interests between aesthetics and resiliency. For example, elevated walkways and raised ground floors to prevent flood damage can be designed to provide a welcoming transition from the street to the building.



An elevated first floor is one design feature meant to protect occupants from flooding.

## Parks and Open Space

Alewife is surrounded by large open spaces that provide a variety of nature based, recreational, and leisure opportunities for residents nearby and citywide. Despite significant challenges to accessing these open spaces, they account for a large portion of citywide open space. As more development takes place in the future, new open spaces must be carefully planned in order to integrate with and enhance the existing fabric of the city.

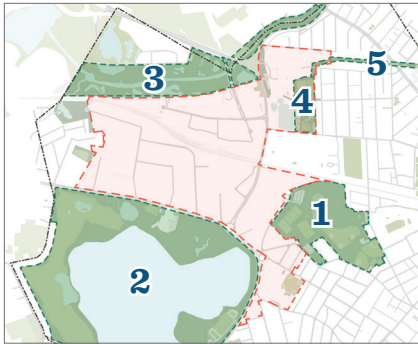

Danehy Park

Danehy Park is one of the City’s most popular open spaces. The 50-acre park is built on the site of the former City landfill which was closed to active dumping in the early 1970s. When the park opened in the 1990s, it increased the City’s open space by 20%.<sup>1</sup> Today Danehy Park serves as one of Cambridge’s most valuable resources, offering residents the opportunity to participate in a variety of recreational activities at facilities including two playgrounds, a track, dog park, and facilities for baseball, soccer, and basketball.



Fresh Pond Reservation

Fresh Pond is a popular destination for residents of Alewife, Cambridge, and beyond. The Fresh Pond Reservation consists of 162 acres of open space surrounding and protecting the 155-acre Fresh Pond Reservoir. While the actual pond is the source of the city’s drinking water, and therefore closed to recreation, the reservation includes an off-leash dog area, a golf course, community gardens, and two miles of trail for walking, running, and biking.

1 City of Cambridge, [cambridgema.gov/CityOfCambridge\\_Content/documents/danehy.pdf](http://cambridgema.gov/CityOfCambridge_Content/documents/danehy.pdf)



### Alewife Brook Reservation

The Alewife Brook Reservation is an important natural and recreational resource. The 130-acre Reservation is home to numerous plants, animals, and bird species and offers opportunities for fishing, hiking, running, and walking. The Reservation contains the Alewife Brook Greenway, linking the Mystic River bike path to the Minuteman Bikeway and Alewife MBTA Red Line Station.



### Russell Field Athletic Complex

The complex of athletic facilities that sits next to Jerry’s Pond includes the Russell and Comeau sports fields and McCrehan Swimming Pool. These recreational facilities cater to a variety of users and allow for free, unprogrammed recreation as well as organized activities, such as high school football and little league baseball. The Alewife Linear Park traces the edge of this recreation area, connecting the Alewife MBTA Red Line Station to the Somerville Community Path.

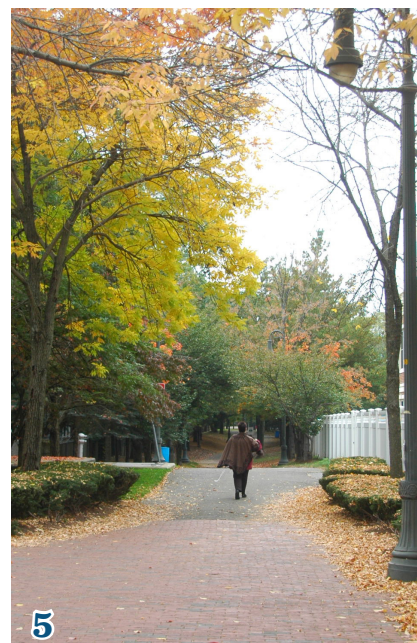

### Alewife Linear Park

The Linear Park is a multi-use path that was created in 1985 after the MBTA extended the Red Line to Alewife. The paved trail offers a direct link to the eastern end of the 11-mile Minuteman Bikeway. In addition to being a busy commuter corridor, it also passes by several parks and playgrounds and is an important recreational asset. The park also connects to the Somerville Community Path, which—based on the MBTA Green Line Extension plan—will be extended to North Point in East Cambridge and eventually to Boston, making the Alewife Linear Park a crucial link in a regional greenway system.

# Mobility

The ability to move within and through Alewife is one of the greatest concerns identified in the community engagement process. The district is crossed by regional parkways that bring in some of Cambridge's highest traffic volumes, creating barriers within the district, and limiting how residents and visitors can move throughout the neighborhood. The MBTA Commuter Rail tracks create an additional barrier between the Quadrangle and Triangle subdistricts. Although the district is served by the MBTA Red Line, Alewife's commuters and visitors use automobiles at a high rate compared to Cambridge overall. Though the City has made strides in creating safe pedestrian and cycling infrastructure in Alewife, there are many gaps in the network, limiting its overall usefulness. Many of the mobility challenges in Alewife are regional, and Cambridge exercises little control over key aspects of the system. Nonetheless, there are local improvements that can make mobility more safe, convenient, and enjoyable for people in Cambridge traveling to, through, or within Alewife.

Learn more about . . .

"Modes of Travel" on page 50

"Commute Time" on page 50

"Automobile Traffic and Regional Concerns" on page 52

"Public Transit" on page 52

"Parking" on page 56

"Walking and Cycling" on page 57

"Connections and Disconnections" on page 58





## The majority of people commuting from Alewife drive to work.

Residents' Commuting Mode Choice

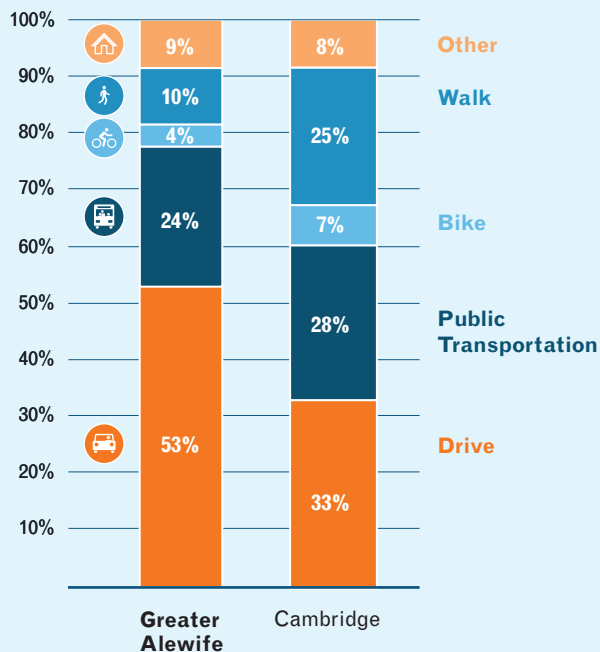

Source: American Community Survey, 2010–2014, 5-year estimates. Due to Census Bureau reporting, this information includes the Alewife district in this plan, as well as pieces of adjacent neighborhoods.

## Modes of Travel

Alewife residents and visitors are more likely to rely on driving than in other parts of Cambridge, even though the district is served by the MBTA Red Line. Fifty-three percent of people living in and around Alewife commute by car, while 38% commute using sustainable modes of transportation (walking, cycling, and public transit). Those proportions are almost the inverse of the city as a whole: only 33% of Cambridge residents drive to work, while almost 60% commute via sustainable modes.<sup>1</sup>

Among surveyed visitors to Alewife (including Cambridge residents, workers in the area, and shoppers), 66% drive to Alewife, compared to 25% of visitors to Kendall Square and 19% of visitors to Harvard Square.<sup>2</sup> The atypical prevalence of drivers in Alewife is likely due to the auto-oriented nature of the urban form, with wide parkways and expansive parking lots that cater to driving. This is compounded by the high concentration of industrial and commercial uses in Alewife which generate a significant amount of daily traffic.

However, the relative auto-dominance observed in Alewife may already be changing. Between 2010 and 2013, weekly transit ridership at Alewife Station has increased nearly 9%. Furthermore, some recent developments in Alewife have generated half of the number of automobile trips during the evening rush hour that were projected prior to construction.<sup>3</sup>

## Commute Time

The average commute time in Alewife is greater than that of Cambridge as a whole. Residents of Alewife have an average commute time of 33 minutes, compared to the citywide average of 24 minutes.<sup>4</sup> Residents from neighborhoods surrounding Alewife Station face some of the longest commute times across the city, even longer than the averages for surrounding areas in Watertown, Belmont, and Arlington.

<sup>1</sup> American Community Survey, 2010–2014, 5-year estimates

<sup>2</sup> Cambridge Customer Intercept Surveys, 2009–2016

<sup>3</sup> Alewife Transportation Update, 2014

<sup>4</sup> American Community Survey, 2010–2014, 5-year estimates



Morning commuters rely on various modes to arrive at the Alewife MBTA Red Line Station.



Bicycles fill the racks at the Alewife MBTA Red Line Station.

### Average Commute Time by Home Location

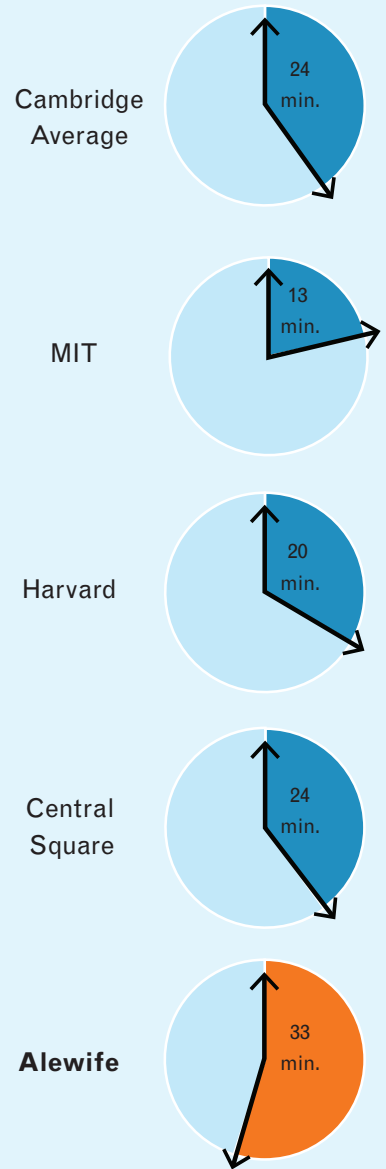

Source: American Community Survey, 2010-2014, 5-year Census tract estimates

## Automobile Traffic and Regional Concerns

Traffic volumes have been fairly stable in recent years across most of Cambridge, despite significant new development, an increase in regional population, and job growth.<sup>5</sup> City policies, combined with larger demographic and economic trends, have decreased automobile use in much of Cambridge, but automobile traffic remains a persistent issue in Alewife. While traffic on Alewife Brook Parkway remained relatively flat between 1999 and 2016, recent traffic estimates along Alewife Brook Parkway north of Cambridgepark Drive show that estimated average daily traffic at that location increased 11% between 2013 and 2016.<sup>6</sup>

Regional transportation patterns have a strong influence on traffic in the district, as a majority of the traffic passing through Alewife neither begins nor ends in Cambridge.<sup>7</sup> This large amount

of through-traffic is not expected to decline in the short or medium-term. Alewife Brook Parkway is significant not only for Alewife and Cambridge, but for the region as a whole, serving as an important thruway and evacuation route. Design and planning of these roadways therefore requires a larger, regional focus.

## Public Transit

Transit Score is a proprietary measure of how well a location is served by public transit, based on the frequency, type, and distance to the nearest stop on a route. Alewife has a Transit Score of 68. While this is higher than the national average, it is slightly lower than Cambridge’s overall score of 72, and is significantly lower than Harvard Square or Kendall Square, which both have a score of 80.<sup>8</sup>

<sup>5</sup> City of Cambridge, Average Daily Traffic Counts, 1998–2016. The last count on many major streets was conducted in 2013.

<sup>6</sup> Ibid.

<sup>7</sup> Based on interpretation of 2010 Central Transportation Planning Organization (CTPO) regional travel demand model data for the Boston Region.

<sup>8</sup> Public transit scores retrieved November 2017 from [walkscore.com/MA/Cambridge](http://walkscore.com/MA/Cambridge).

### Traffic has remained relatively flat in Alewife since 1998, though there has been recent traffic growth on Alewife Brook Parkway.

Average Daily Traffic Counts in Alewife, 1998-2016

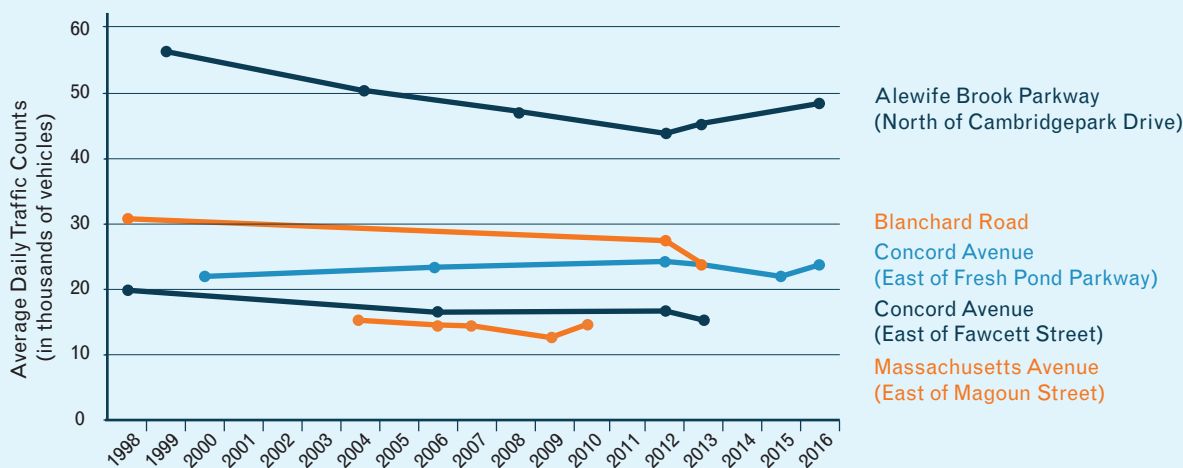

Source: City of Cambridge

Entries at Alewife MBTA Red Line Station, 1997-2013

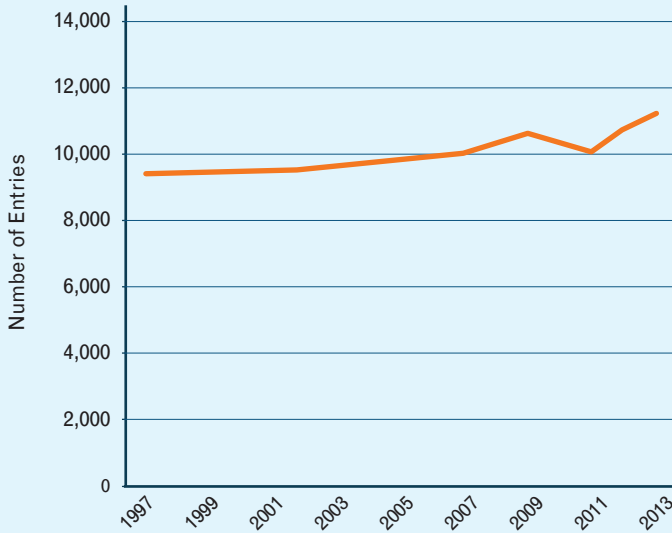

**While daily station use has increased in recent years, the Alewife MBTA Red Line Station still only receives a fraction of the riders of other Red Line Stations in Cambridge (11,221 daily boardings in 2013 compared to 23,199 at Harvard, 16,525 at Central, and 15,433 at Kendall).**

Source: Alewife Transportation Update, 2014



Heavy traffic on major roadways in Alewife.



Route 84 on Acorn Park Drive connects Alewife Station with Arlington Heights.

### Subway

As the northern terminus of the Red Line, the Alewife MBTA Red Line Station serves residents of adjacent neighborhoods as well as commuters from outside the city. However, Alewife experiences only a fraction of the station usage compared to other parts of Cambridge. In 2013 there were only 11,221 people entering the Red Line at Alewife daily, compared to 23,199 at Harvard, 16,525 at Central, and 15,433 at Kendall.<sup>9</sup> Alewife is the most reliable stop on the Red Line; as the origin stop, only 2% of passengers experienced a longer-than-expected wait. This figure stands in contrast to other Cambridge MBTA Stations like Kendall, where 12% of passengers waited longer than expected.<sup>10</sup>

### Bus

Alewife Station is also a significant bus hub. The station provides connections to numerous MBTA bus routes and other local shuttles. Private carriers provide shuttle bus service to and from Alewife for companies along the Route 2 and Route 128 corridor, and a private intercity bus to New York City leaves from Alewife.

MBTA bus service is uneven in the Alewife area. Bus lines serving Alewife station are on time only 64% of the time, and bus lines running on Concord Avenue through Alewife are on time 68% of the time. The 72 bus line, which runs across the edge of the Alewife district, is one of Cambridge's most on-time buses, leaving stops on time 79% of the time.<sup>11</sup> However, members of the public noted that many of these buses run too infrequently to be considered a reliable form of transportation, with routes like the 78 and 83 running every half hour during the week and only once an hour on Sundays.

<sup>9</sup> MBTA Ridership and Service Statistics, 2014. While 2016 ridership data was released by MBTA, station-specific entry data was not; 2013 represents the latest data available for station entries.

<sup>10</sup> MBTA Dashboard Data, 2016

<sup>11</sup> Ibid.

## Buses running into Alewife Station do not hold to their schedule often enough to be considered reliable.

Bus Route Reliability (Percent of Stops Made on Time), 2016

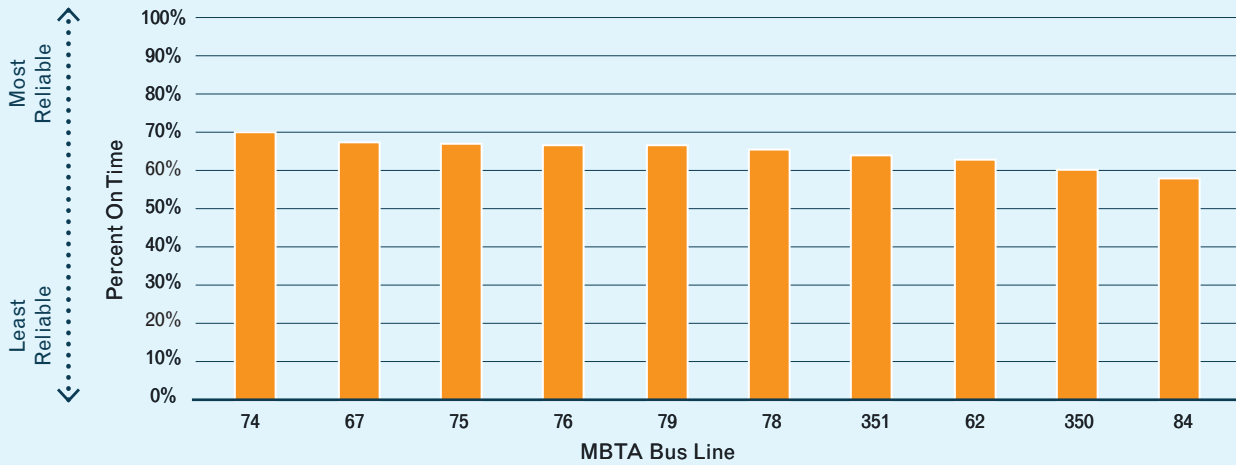

Source: MBTA Dashboard Data, 2016



### Alewife Transportation Management Association

Alewife is one of the few Cambridge neighborhoods that has a Transportation Management Association (TMA). The TMA is a nonprofit organization that provides a shuttle and other transportation programs for a variety of public and private employers in Alewife. The shuttle connects the Alewife Quadrangle to the Alewife MBTA Red Line Station, linking to regional bus and train connections. In addition to a shuttle, the TMA offers carpool and vanpool services, and resources for bicyclists. Funding for the TMA comes from its corporate members and other sources.<sup>12</sup>

### Transportation Network Companies

Technology-driven businesses have emerged in recent years as another important part of the mobility ecosystem. Smartphone-based ride-hailing services such as Uber and Lyft offer an on-demand mobility option, but the aggregate impact of these services in Alewife and Cambridge overall is not yet known.

<sup>12</sup> Alewife TMA, 2017, [alewifetma.org/About-Us](http://alewifetma.org/About-Us).

## Parking

Surface parking lots cover approximately 27% of the land in Alewife. This condition is characteristic of most industrial parks and suburban retail areas. Most commercial buildings within the district rely on surface parking between building entrances and the street, making these buildings accessible to vehicles but unattractive to pedestrians. Furthermore, surface parking and impermeable surfaces will become increasingly problematic in Alewife as the threat from climate change-related flooding and heat impacts continues to grow.

While surface parking has dominated Alewife’s landscape in the past, recent development has employed different parking strategies. Recent residential developments have sought lower parking ratios and consolidated parking in parking structures.

The MBTA Station is the only publicly-owned parking garage in Alewife, containing 2,733 vehicle parking spaces and 174 bicycle parking spaces. There is a fee to park in the MBTA parking garage, which frequently reaches capacity. Public metered parking exists along portions of Fawcett Street and Wheeler Street in the Quadrangle, and





The Alewife MBTA Station parking garage, the only publicly-owned parking garage in Alewife, is almost always at capacity.



### Walk, Transit, and Bike Scores for Alewife and Cambridge

**Walk, Transit, and Bike Scores in Alewife are below the Cambridge average. Relatively few people choose active transportation (walking and cycling) when moving through Alewife today.**

	Walk Score 	Transit Score 	Bike Score 
Cambridge Average	88	72	93
<b>Alewife</b>	<b>68</b>	<b>68</b>	<b>92</b>
Central Square	98	73	99
East Cambridge	90	84	94

Source: WalkScore.com, 2017

there are a few handicapped parking spaces along Smith Place, Huron Avenue, and Concord Avenue. Bicycle parking tends to be concentrated near the open spaces in the district.

## Walking and Cycling

Alewife’s importance in the greater regional transportation network can pose challenges for walking and cycling. In particular, Alewife Brook Parkway carries a large volume of regional traffic, but acts as a barrier between different parts of the district. There are very few pedestrian crossing points along the length of the parkway, and bicyclists and pedestrians have to share the narrow sidewalk. The width of the roadway, large building setbacks, and surface parking lots between buildings and the street give the area a very suburban, vehicle-oriented character. The street lacks a defined street wall, pedestrian scale, and amenities that give an urban street a sense of place. All of these factors combine to make walking and cycling uncomfortable.

In addition to Alewife Brook Parkway, areas of the Alewife District are still not considered walking- or cycling-friendly by members of the

public. Many parts of the Quadrangle have sidewalks that are substandard, in poor condition, or simply nonexistent. While some of the district has high-quality cycling infrastructure, such as the Alewife Linear Path, the links between subdistricts and across major roadways are more difficult.

However, recent infrastructure improvements in the district are changing the viability of walking and cycling. They include:

- Multi-use paths in Fresh Pond Reservation, Alewife Brook Reservation, and Danehy Park.
- Separated bike lanes on Concord Avenue.
- Sidewalks in parts of the Alewife Quadrangle.
- Bike lanes in the Triangle that connect with the path network that includes links to the Minuteman Bikeway, the Fitchburg Cutoff Path to Belmont, the Alewife Linear Park, and the Somerville Community Path.
- Bluebikes bike share stations at the Alewife MBTA station, Danehy Park, and Fresh Pond.

## The density of intersections in Alewife is very low, impeding walkability in the area.

### Intersection Densities in Alewife and Cambridge

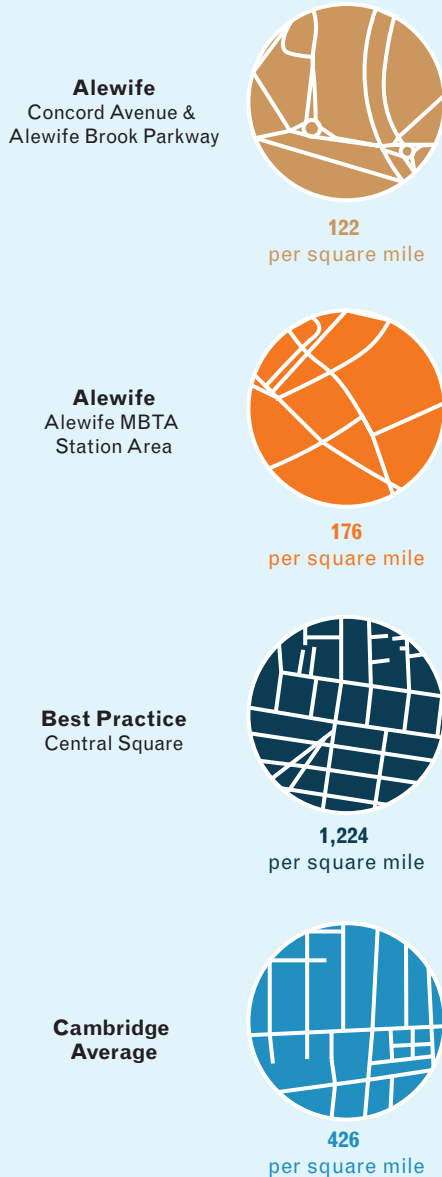

Source: Cambridge GIS; Envision Cambridge analysis

## Connections and Disconnections

The network of streets and paths in Alewife is inconsistent and disconnected compared to other neighborhoods in Cambridge. Someone traveling through the district may find themselves traveling into or across heavy automobile traffic, hitting dead ends, or forced into winding detours to get between two points that are not far apart.

Intersection density, or the number of intersections in an area, is a factor that contributes to creating an active, walkable neighborhood. Areas with a high intersection density have smaller blocks, which increases the number of destinations an individual can reach efficiently. Alewife has a much lower intersection density than Cambridge overall. On average, Alewife has 176 intersections per square mile, compared to 426 intersections citywide. Concord Avenue and Alewife Brook Parkway have the lowest intersection density in Alewife, with 122 intersections per square mile.<sup>13</sup>

<sup>13</sup> Center for Neighborhood Technology, 2015.

## Thoughts from the Community: Mobility

Mobility challenges emerged frequently in discussions with community members, including concerns about traffic congestion, transit reliability, and pedestrian and bicyclist safety in Alewife. Vehicular congestion was consistently considered a challenge, specifically on or near the parkways. There was a strong desire to decrease congestion and the volume of drivers moving through Alewife. Shuttle buses, pedestrian bridges, and more or safer bicycle lanes were all suggested as ways to improve mobility.

Safety and equity also emerged as themes in conversations about mobility. Community members felt safety could be improved with better infrastructure or temporary measures such as crossing guards. Many members of the community acknowledged the delicate balance between the needs of drivers and those of other transportation modes, but that their goals were not always in opposition. Some members of the public noted that these groups are not mutually exclusive—people will be drivers, pedestrians, cyclists, and transit riders, depending on the situation. Safety, variety of transportation mode choices, and the reliability of those choices were all noted for their importance on equity and economic opportunity.



“I think it’s important to provide better public transit access to the Alewife station and bike infrastructure on Rindge Ave, Sherman Street, Mass Ave, and Alewife Brook Parkway.”

— North Cambridge resident via online survey

“We need to make cycling safer, speed up buses that connect to [the rest of] Cambridge, and improve the pedestrian experience everywhere in Alewife.”

— North Cambridge resident via online survey

# Climate & Environment

**A**lewife has a complicated environmental history as a former marshland that was subsequently developed as an industrial area. This environmental legacy adds complexity to the future development of Alewife: its location and topography make the district vulnerable to flooding; and its industrial history has created soil contamination and compaction, as well as a built environment that exacerbates the effects of extreme heat events. In addition, the district today utilizes a disproportionate amount of energy compared to the rest of Cambridge, and faces heavy regional traffic and subsequent air quality concerns. Plans for the future must address these conditions directly.

Learn more about . . .

“Climate Change Impacts” on page 62

“Tree Canopy” on page 64

“Energy and GHG Emissions” on page 64

“Water” on page 66

“Air Quality” on page 68

“Soil Quality” on page 68



## Climate Change Impacts

The City developed a Climate Change Preparedness and Resilience (CCPR) Plan for Alewife. It is part of the continuing effort by the City to address climate change impacts such as flooding and higher temperatures. The Envision Cambridge planning process worked in coordination with the CCPR planning process to address the challenges of climate change in a holistic way. Alewife is particularly susceptible to the impacts of climate change due to the significant amount of impervious surfaces, lack of tree canopy, and location in the floodplain. Furthermore, the district contains critical assets, resources, and populations that are more vulnerable to climate change impacts. For these reasons, planning and preparedness for the impacts of climate change are a priority in Alewife.

### Flooding

Compared to the remainder of Cambridge, Alewife is one of the areas most vulnerable to flooding. Flooding is expected to be increasingly frequent and extensive, resulting from both increased precipitation and sea level rise. According to the CCPR Plan for Alewife, the 10-year (10% annual probability), 24-hour precipitation event could flood 6% of Alewife by 2030, and 10% by 2070.<sup>1</sup> In the 100-year (1% annual probability), 24-hour precipitation event, the land area affected by flooding is greater than 24% for the year 2030 and greater than 30% for 2070. The area will also be vulnerable to flooding caused by storm surge. By 2055, due to sea level rise, a storm surge from the Boston Harbor could flank or overtop the Amelia Earhart Dam on the Mystic River, allowing waters to surge into Alewife Brook and flood the Alewife district. Much of Alewife has between 10% and 20% annual probabilities of flooding by 2070 if sea level rises at the rate projected in the Climate Change Vulnerability Assessment (CCVA).<sup>2</sup> If salt water were to reach Fresh Pond,

it could contaminate the City's drinking water supply.

Alewife is also susceptible to flooding due to its lack of permeable surfaces, uneven distribution of open space, dense clay soils, and high water table. Excluding open space areas such as Fresh Pond, nearly three-quarters of the Cambridge Highlands neighborhood (which includes the Quadrangle and Shopping Center subdistricts) is impervious.<sup>3</sup> Reducing impervious surfaces will be an important part of the overall resilience strategy in Alewife. Although clay-rich soil across Alewife slows infiltration, and the high water table limits the volume of soil available to absorb stormwater for more significant precipitation events, increasing the amount of permeable surface also helps address urban heat island effect (the phenomenon in which an urban area is significantly warmer than surrounding rural, less developed areas) and improves the quality of the public realm. Compensatory stormwater storage requirements, as well as gray and green infrastructure such as rain gardens and bioretention basins (landscaped depressions or shallow basins used to slow and treat on-site stormwater runoff) may be necessary to meet stormwater requirements.

### Extreme Heat

Climate change will cause extreme heat to be more frequent and impactful, affecting both the indoor and outdoor environment. Average temperatures are increasing and it is projected that by mid-century, the number of days above 65 degrees Fahrenheit will exceed the number of days below 65 degrees Fahrenheit in Massachusetts. Alewife is particularly vulnerable to increased temperature and more frequent heat waves due to the amount of paving and lack of tree coverage. This will intensify temperature increases if action is not taken. Climate change will cause increased temperature in Alewife, as heat waves (three or more days of high temperatures) are

<sup>1</sup> CCPR, 2017, subject to revisions based on ongoing analysis. A 10-year storm has a 10% chance of happening in any given year. A 100-year storm is one that has a 1% chance of happening in any given year.

<sup>2</sup> City of Cambridge Climate Change Vulnerability Assessment (CCVA), 2017, subject to revisions based on ongoing analysis.

<sup>3</sup> City of Cambridge GIS, Envision Cambridge analysis.

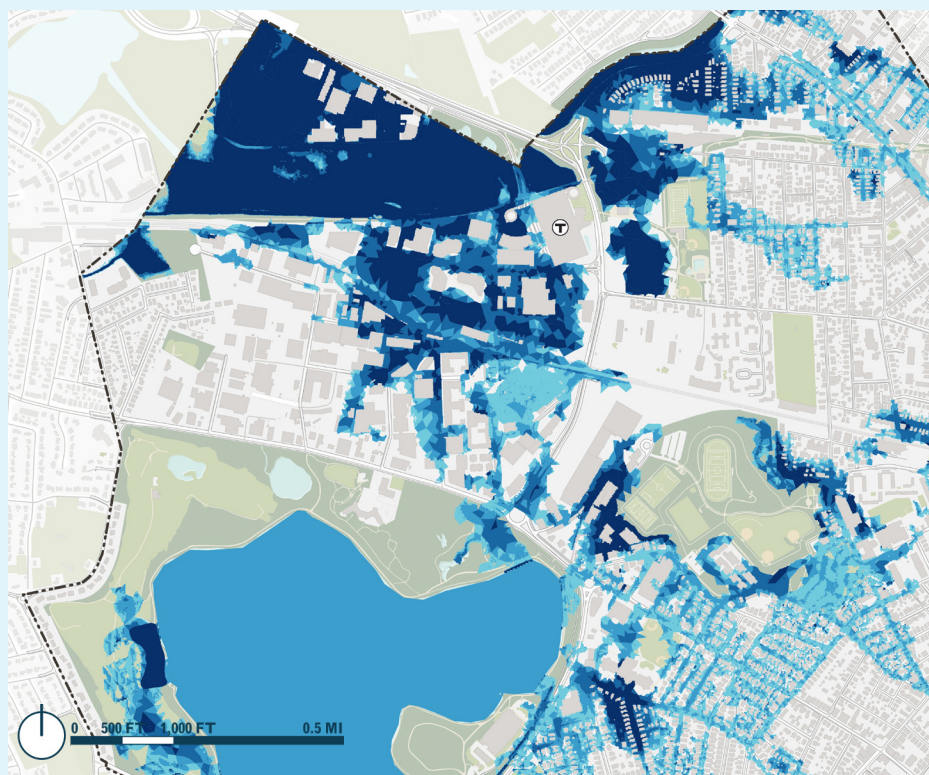

**Alewife will face significant flooding as climate change increases the severity and frequency of extreme precipitation.**

Projected flooding from a 24-hour, 100-year (1% annual probability) precipitation event in 2070

Source: CCPR, 2017

Depth in feet

- < 0.5
- 0.5 - 1.0
- 1.0 - 2.0
- 2.0 - 3.0
- > 3.0



**Alewife is almost entirely covered by impervious surfaces, exacerbating the effects of flooding and extreme heat.**

Impervious Surfaces, 2010

- Building Roof
- Pavement

Source: Cambridge GIS



Parking lots and impervious surfaces exacerbate the impacts of stormwater flooding and extreme heat.

predicted to be much more common: by 2030, the number of days above 90 degrees each year could triple citywide, and by 2070 there could be more than three months each year with daily temperatures over 90 degrees.<sup>4</sup>

## Tree Canopy

Alewife is surrounded by two large conservation areas: Fresh Pond Reservation and Alewife Reservation. These areas provide some of the largest and most well-canopied open spaces in Cambridge. However, the developed portion of Alewife has minimal tree canopy coverage when compared to the rest of Cambridge. This lack of tree canopy exacerbates the urban heat island effect and has negative impacts on local air quality and the quality of the public realm.

## Energy and GHG Emissions

The powering, heating, and cooling of buildings in Cambridge account for 82% of Cambridge's greenhouse gas (GHG) emissions. Buildings in Alewife have higher energy use intensity per square foot than similar buildings in Cambridge.<sup>5</sup> The growing demand for laboratory space in Alewife could lead to even higher emissions for the district, as the amount of energy consumed per square foot is greatest in laboratory buildings. Without concerted effort to meet the citywide goal of net zero GHG emissions from buildings by 2050, inefficient office and laboratory buildings will continue to drive high emissions for the district.

As of November 2017, there were two solar photovoltaic installations in the Alewife district. There is significant potential for more solar installations in Alewife as many existing buildings have large roof areas. New development in the

<sup>4</sup> CCPR, 2017, subject to revisions based on ongoing analysis.

<sup>5</sup> Cambridge Building Energy Use Disclosure Ordinance (BEUDO) data, 2015. The BEUDO covers non-residential properties of at least 50,000 square feet, residential properties with 50 or more units, and municipal facilities of at least 10,000 square feet.





**A lack of tree canopy in Alewife results in less shade, increased surface temperatures, and fewer trees to sequester carbon.**

Existing Tree Canopy, 2009

Source: Cambridge GIS

**Alewife contains some of the most energy intensive office buildings in Cambridge.**

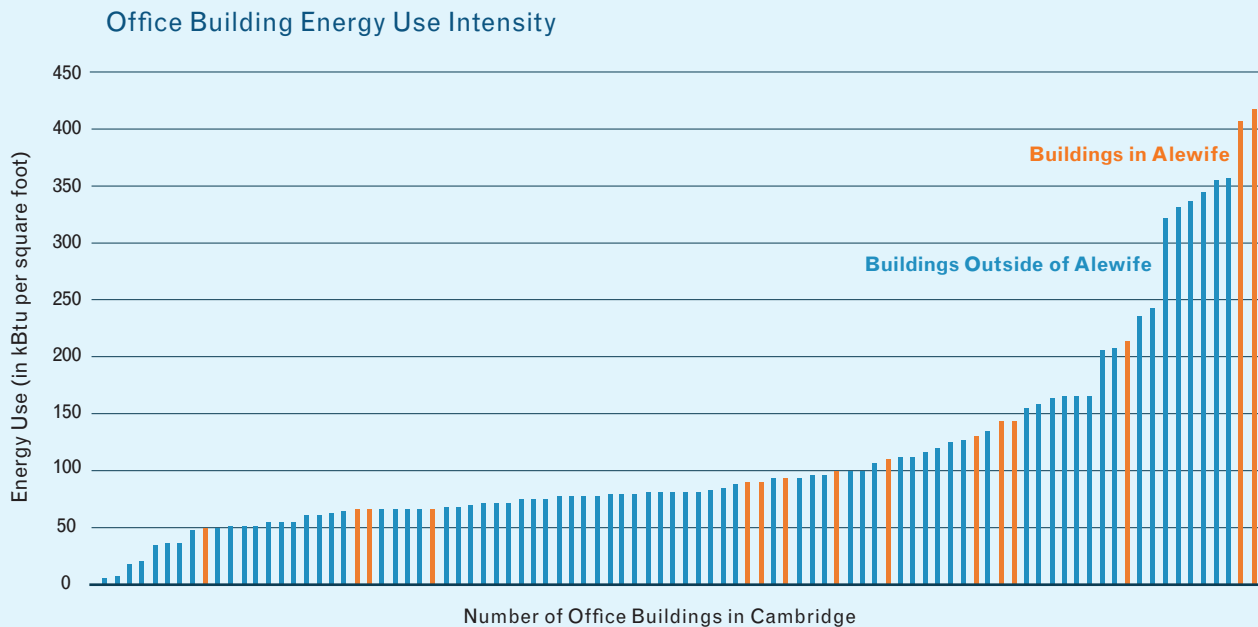

Source: Cambridge Building Energy Use Disclosure Ordinance (BEUDO) data, 2015

future can also be built to integrate clean energy. Furthermore, there is significant potential for district energy in Alewife, wherein energy is supplied to individual buildings from one or more centralized energy sources. Based on an analysis of projected energy demand, Alewife is an ideal location for district energy.

---

## Water

### Drinking Water

The Cambridge Water Department is a municipally-owned utility whose mission is to provide a safe, uninterrupted water supply of the highest quality to the Cambridge community. The City was given the right to acquire the Fresh Pond Reservoir as a source of drinking water in 1888. Today, the Water Department remains on-site in Alewife, just outside this plan’s study area. Water from Fresh Pond, fed by upland reservoirs in Lincoln, Lexington, Weston, and Waltham, is purified at the Walter J. Sullivan Water Treatment

Facility and transported to the rest of Cambridge. The Fresh Pond Reservation, 162 acres of open space surrounding and protecting the 155-acre reservoir, also serves as a recreational asset.

In 2016, severe droughts decreased the amount of water available in Cambridge’s drinking water system, requiring the City to temporarily draw from the regional system operated by the Massachusetts Water Resources Authority. The event raised awareness of how critical it is to protect the water supply. While drought may not present a serious immediate risk, salt contamination of the reservoir due to storm surge that flanks or overtops the Amelia Earhart Dam has been raised as a serious concern in the CCPR Plan.

### Water Quality

In older cities like Cambridge, stormwater and sanitary sewage flows were originally collected and conveyed in a single “combined” system of pipes. These pipes initially discharged their flows to water bodies such as the Charles River and Alewife Brook. Later, the flows were redirected



The Fresh Pond Reservation includes Little Fresh Pond, pictured here.



The Walter J. Sullivan Water Purification Facility sits on Fresh Pond and services all of Cambridge.

to regional treatment facilities, but the outfalls to open water bodies were retained for overflows. During times of dry weather or low-precipitation events, the pipes in the system generally had enough capacity to convey the combined stormwater and sewage to treatment facilities. During large storms however, the system would become overloaded, and overflows containing a mixture of stormwater and untreated sewage would discharge to water bodies.

For decades, the City has worked to separate sewage and stormwater into independent systems to minimize combined sewer overflows. Approximately 40% of the sewer and stormwater collection system owned and maintained by Cambridge has been separated since the 1930s. The City recently completed a large sewer separation project in neighborhoods along Huron and Concord Avenues, which are part of the Alewife Brook watershed. Between 1998 and 2016, the volume of untreated combined sewer overflow discharged into the Alewife Brook decreased

**Between 1988 and 2016, the volume of combined sewer overflows into Alewife Brook has decreased 85%.**

Reduction of Annual Untreated CSO Discharge in Alewife Brook / Upper Mystic River

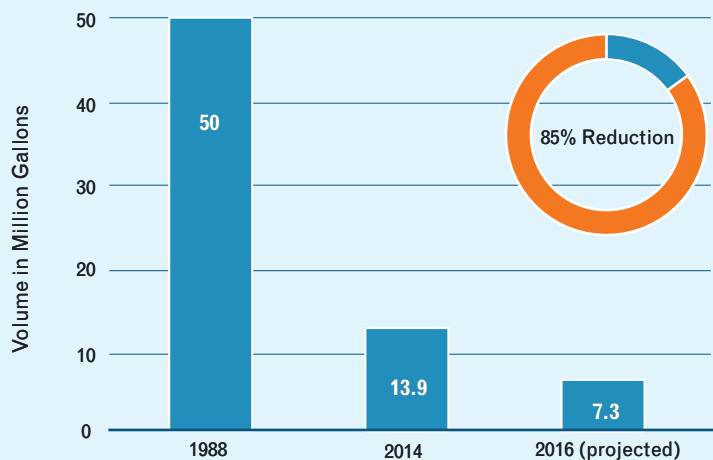

Source: MWRA, CSO Annual Report, 2015



High traffic volumes on roads and parkways contribute to poor air quality in Alewife.

by 85%.<sup>6</sup> Improvements in Alewife in particular, such as the new Alewife Brook Stormwater Wetland, have also been critical to achieving water quality improvements.

While the City addresses combined sewer overflows, polluted runoff washing into waterways (called “non-point source pollution”) remains a threat to water quality in Alewife. The district has a large amount of impervious surfaces, such as parking lots, buildings, and streets, that increase the risk of non-point source pollution in waterways near Alewife, a risk that is likely to increase with greater precipitation predicted as the climate changes.

## Air Quality

As heavy polluting industries have left Cambridge and the surrounding region, air quality has greatly improved. However, localized impacts of air pollutants remain in Alewife. High traffic volumes are known to produce local air pollution near large roadways and can have negative impacts on public health and the environment. Therefore the localized air quality adjacent to the parkways is likely poor, compared to nearby

neighborhoods that are buffered from regional automobile traffic. Higher temperatures worsen air quality and make air pollution more dangerous. Without a substantial shift away from fossil fuel vehicles, air quality concerns in Alewife may only grow with climate change impacts.

## Soil Quality

Alewife contains some of Cambridge’s most undisturbed soils as well as some of the most contaminated. Fresh Pond and the Alewife Brook Reservation make up some of the only large stretches of soil in Cambridge that have not been subject to excavation or landfill. At the same time, Alewife is also home to a significant number of contaminated sites. Contaminated sites are not only an environmental issue, but also require site remediation that increases the costs of redevelopment or the reuse of parcels.

<sup>6</sup> Cambridge Department of Public Works, 2017, <https://www.cambridgema.gov/Departments/publicworks/Services/combinedseweroverflows>

## Thoughts From the Community: Climate and Environment

Climate change preparedness was often mentioned as a major concern in Alewife due to the district's vulnerability to flooding and extreme heat. Community members discussed the need to protect both existing and new buildings, as well as roads and other critical infrastructure, from future flood impacts. Some community members felt that development in Alewife's flood-prone areas should be avoided entirely, while others felt development could mitigate climate change impacts through the implementation of resiliency measures.

In discussions about climate and environment issues, community member recognized the value of open spaces in the Alewife area including Fresh Pond, Alewife Reservation, and Danehy Park. These open spaces were considered assets because they provide tree canopy and broad pervious surface coverage, reducing heat island effect and slowing the rate of infiltration from stormwater.

Lastly, several residents expressed a desire for more open spaces, including neighborhood parks. There was a strong emphasis on creating a connected open space network with safe pedestrian and bicycle connections.



“I really hope that carefully planned housing and commercial development can help maintain the integrity of the Alewife Reservation for climate management and recreation.”

— Cambridge resident via online survey

“Alewife seems ruined by decades of car-centric planning. The area needs more green space, better pedestrian walkways, and improved bike infrastructure.”

— North Cambridge resident via online survey

# Housing

Historically, Alewife sat in the middle of several residential neighborhoods, but there was very little housing within Alewife itself. In 1971, the Fresh Pond Apartments and Rindge Tower Apartments opened, bringing a large residential presence into Alewife. Subsequent plans for Alewife have envisioned housing in the district, and starting in the 2000s, new housing developments were built in the Alewife Triangle and Quadrangle. Following the 2005 Concord-Alewife Plan, housing increased from 30% of Alewife’s land use to 50%. Future development in Alewife has the potential to significantly increase the city’s housing stock.

Learn more about . . .

“Character of Housing in and Around Alewife” on page 72

“Recent Development” on page 74





## Character of Housing in and Around Alewife

Alewife and the areas surrounding the district contain a diverse range of housing types, encompassing a variety of densities and architectural styles. Each of the neighborhoods that make up greater Alewife has a particular character and built form that responds to the area's context and development history.

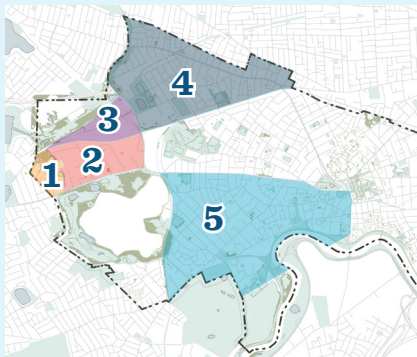

### Cambridge Highlands

Cambridge Highlands, located adjacent to the Alewife Quadrangle at the western edge of Cambridge, is a community of mostly small single-family homes, with a few multifamily buildings and townhouses. Much of this neighborhood is buffered from the Quadrangle's industrial uses by the Sancta Maria Nursing Facility or wooded areas.

### Quadrangle

The Quadrangle, located directly east of the Cambridge Highlands, is historically an industrial area, but several large, recent developments have increased the amount of multi-family housing.





### Triangle

The Triangle, north of the Quadrangle, has transitioned in recent years from a primarily commercial office campus into a mixed use district, incorporating residential and retail uses. The newer residential buildings, in general, can be characterized as contemporary mid-rise apartments.



### North Cambridge

North Cambridge, on Alewife's northeastern side, contains a diverse mix of housing types, including single family, two-family, and three-family homes, and high-density, multi-family developments such as the Fresh Pond Apartments and Rindge Towers Apartments.



### West Cambridge

On Alewife's southeastern edge, West Cambridge is a mix of single-family, two-family, and three-family homes.



Several multi-family housing developments have introduced more units to parts of Alewife in recent years.

## More than 1,000 new housing units were completed in Alewife in 2014.

New Housing Units by Year Completed, 2001-2016

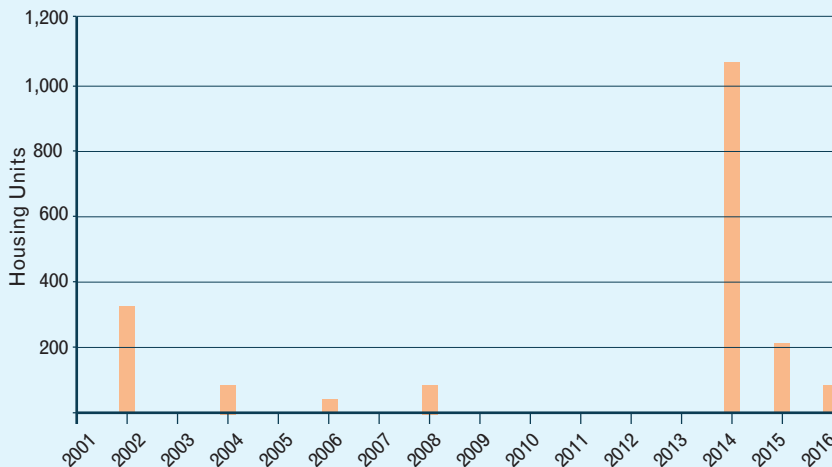

Source: Cambridge Development Log, 2001-2016

## Recent Development

Housing in the Alewife study area was relatively uncommon through the 20th century. In 2003, the first mid-rise housing development opened in the Alewife Triangle, offering high-end amenities and access to the MBTA Red Line across the street. Three years later, the 2005 Concord-Alewife Planning Study and subsequent rezoning incentivized residential development in the Triangle and eastern portion of the Quadrangle. The Great Recession largely froze lending and development starting in 2007; however, beginning in 2013, Alewife experienced a residential development boom. Between 2013 and 2016, 1,382 housing units were constructed in Alewife.<sup>1</sup> Of those, 1,054 units were completed in 2014 alone, as part of three mid-rise developments in the Triangle and Quadrangle. Asking rent and unit makeup varied among these developments; for example, one development included 74% one-bedroom and 26% two-bedroom units, with asking rents starting at \$2,555 as of November 2017.<sup>2</sup>

1 CDD Development Log, 2017. This data set only tracks large projects, defined as having ten or more housing units or more than 50,000 gross square feet of development.  
 2 City of Cambridge Special Permit 270, 2012; windsoratcambridgepark.com.

## Thoughts From the Community: Housing

Housing affordability, location, and available inventory were voiced as issues in Alewife and Cambridge as a whole. Many community members felt more housing is necessary in Alewife, viewing housing development in the district as critical to increasing housing supply in Cambridge overall. Others thought housing development was not appropriate given the district’s vulnerability to flooding and heavy automobile traffic. Additionally, some community members accepted the idea of new housing, but wanted it in historic styles that better complemented the adjacent city fabric.

Some community members voiced concerns that recent housing developments are not physically integrated with one another or with the adjacent neighborhoods, taking away from the walkability, livability, and sense of community they hope for in the district. In their opinion, housing should be designed to facilitate social cohesion, for example by including playgrounds and porches, and walkable streets and sidewalks.



“Alewife needs fewer ‘luxury’ apartments and more housing that people can actually afford.”

— North Cambridge resident via online survey

“Before building more housing in Alewife we need the open space, bike lanes, restaurants, and grocery stores that make an area livable.”

— Cambridge resident via online survey

“I hope Alewife is not overdeveloped, but becomes an area with affordable housing for families and elders to remain in Cambridge.”

— Cambridge Highlands resident via online survey

# Economy

**A**lewife is a critical part of the economy, both for Cambridge and for the wider region. The district provides lower-cost space for innovation-based businesses and new firms, particularly in the life sciences industry. These firms have fueled Cambridge’s economic growth in recent decades. Furthermore, Alewife is one of the last parts of Cambridge that currently supports light manufacturing and commercial businesses, which offer well-paying, low barrier-to-entry jobs. In these ways, Alewife could continue to play an important role as a generator of economic diversity and source of equitable employment opportunities for residents of Cambridge.

Learn more about . . .

“Jobs in Alewife” on page 78

“Mix of Employers” on page 78

“Business Typologies” on page 80



## Jobs in Alewife

Alewife contains approximately 8,000 jobs, or roughly 7% of all jobs in Cambridge. The largest proportion of jobs in Alewife are in professional and technical services (36%). Unlike Cambridge as a whole, Alewife has relatively few jobs in educational services, but proportionally more jobs in retail, arts and entertainment, and manufacturing and construction. In fact, Alewife-based firms employ 46% of all construction and utilities workers based in Cambridge. Furthermore, the proportion of low-wage workers in Alewife is similar to that of Cambridge as a whole, while the proportion of workers without a bachelor's degree is higher in Alewife. One interpretation of this difference is that jobs for workers with less formal education pay better in Alewife than in Cambridge as a whole.

## Mix of Employers

Alewife today has a dynamic mix of employers that serve an important function in the local and regional economy. While the district is located close to the heart of the regional economy, the relatively inexpensive land attracts the type of employers and jobs that might otherwise be priced out of Cambridge. Many of these employers, such as light manufacturing and commercial businesses, require warehouse-style industrial space or sizable building floorplates. Some national retailers depend on larger building footprints, as well. Others, such as small life sciences businesses and office uses, may be able to locate in other areas of Cambridge but depend on lower rents available in Alewife.

**While there are proportionately fewer workers with a Bachelor's degree in Alewife than the rest of Cambridge, workers with less formal education tend to make higher wages in Alewife than elsewhere in Cambridge.**

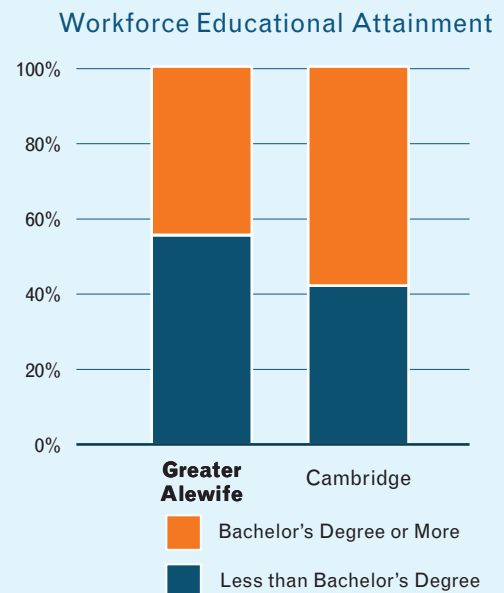
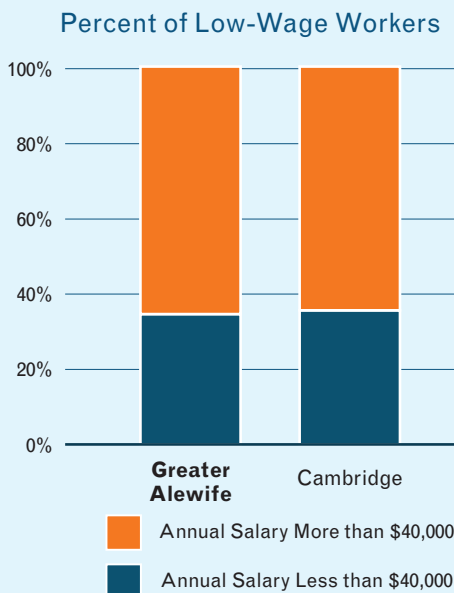

Source: US Census Bureau, LEHD Origin-Destination Employment Statistics (LODES), 2015

## Thoughts from the Community: Economy

Community members acknowledged the changing economic conditions of the city. Cambridge's role in the regional economy was frequently discussed, as some felt that the influx in high-paying jobs benefits only a certain population, squeezing out the middle class or leaving low-skilled residents worse off.

The public supported Alewife's existing industrial business cluster as a source for jobs that do not always require advanced degrees, often a necessity among other industries in Cambridge. Community members also enjoyed the unique character and history that these businesses retain for the city.

From a consumer perspective, some people appreciated that the suburban-style shopping centers contain national retailers not found in most of Cambridge, but many expressed that these shopping opportunities lack the charm and diversity that they feel is unique to Cambridge, desiring a more walkable "main street" environment.



“Attracting technology start-up jobs is wonderful, but this city isn’t going to sustain itself entirely with high-paying jobs. Cambridge must avoid focusing only on attracting wealthy companies.”

— Cambridge resident via online survey

“In the future I hope Alewife becomes a real ‘place.’ We need to attract stores and a retail hub, and develop an Alewife Square that is comparable to Harvard, Porter, and Kendall.”

— Cambridge resident via online survey

## Business Types

There is a diverse mix of businesses in Alewife today. Types range from light manufacturing and lab space to national retail chains including grocery stores and several big box retailers. The business profile has evolved over time and continues to do so today.



### Light Manufacturing and Light Industrial Use

Alewife is home to many light manufacturing and light industrial businesses. These businesses bring diversity to the overall economy, offer well-paying jobs with low barriers to entry, and provide unique products and services to the region. Such businesses include Iggy’s Bread of the World bakery; wood product companies Anderson McQuaid and Longleaf Lumber; a scene shop for the American Repertory Theater; manufacturers and suppliers of water infrastructure, motors, and pool equipment; and other companies that have large space requirements for storage and distribution. Automobile-related uses, such as gas stations and body shops, are also found throughout Alewife.



### “Back Office” Functions

Many employers want to locate in Cambridge, but do not need or cannot afford the high-end office space found in places like Kendall Square. One example is the Social Security Administration (SSA), which rents space in the Alewife Quadrangle. The SSA requires less expensive office space than would be found elsewhere in Cambridge, while providing a large number of jobs for people at a wide range of pay grades and levels of educational attainment.





### Biotech and Lab

Cambridge is famous for its high tech and life sciences industries centered in Kendall Square. The desirability of a Cambridge address has drawn in powerful multinational companies like Google, Biogen, and Novartis. Though these companies form an important backbone for the Cambridge tech and life sciences industries, their need for space and market power can crowd out startups and smaller businesses that cannot afford high rents. Alewife serves as an opportunity for start-ups and small labs to locate in Cambridge despite fierce competition for space.



### Consumer-Facing Businesses in Light Industrial Spaces

Alewife's light industrial building stock caters to many employers beyond light industrial and heavy commercial users, particularly consumer-facing businesses that require large amounts of space. The district is home to many athletic uses, including a rock climbing gym, a gymnastics instruction center, a fencing center, and more.



### National Retail

Many national retailers, which typically locate in spaces that are larger and more standardized than space available in cities like Cambridge, have located in Alewife. Suburban-style shopping centers flank Alewife Brook Parkway, where they host grocery stores, big box retailers, banks, and fast-casual restaurants.

# Community Wellbeing

As its residential population grows, Alewife is transforming into a mixed-used district. Its large open space resources, shopping destinations, and public transportation draw visitors and residents alike to the area. However, the auto-centric and suburban development patterns of the past make it difficult to move around the area; and the district lacks an urban square typical of other Cambridge neighborhoods. New development should create a pedestrian-friendly environment that improves mobility and promotes street activity. New parks and public spaces, including libraries and community centers, can strengthen community ties and create a more complete neighborhood.

Learn more about . . .

“Demographics” on page 84

“Population Density” on page 88

“Community Spaces” on page 88



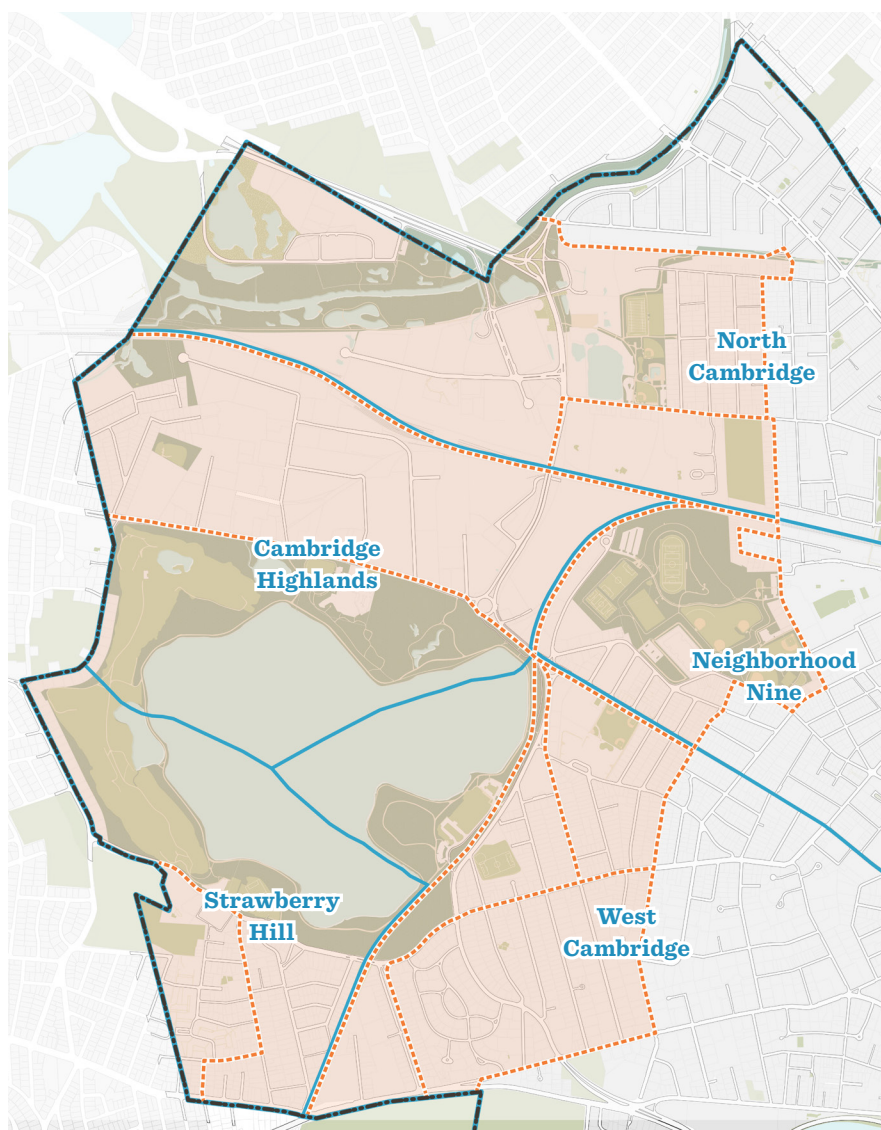

### Neighborhoods and Census Boundaries

- Census Block Groups Used
- Neighborhood Boundaries
- Cambridge City Line

## Demographics

Public data on the demographics of Alewife do not accurately portray the population today because the Alewife district does not strictly align with boundaries used by the US Census. As such, a broader study area has been included for the purposes of demographic analysis of the Alewife area. This analysis encompasses parts of the Cambridge Highlands, Strawberry Hill, North Cambridge, Neighborhood Nine, and West Cambridge. For the purposes of this analysis, we call this area “Greater Alewife.” Together, this Greater Alewife area contains nearly 13,000 people, approximately 12% of the Cambridge population.

### Race, Ethnic Origins, and National Origins

The Greater Alewife neighborhood is relatively more diverse than the remainder of Cambridge. Of those residing in Greater Alewife, 53% are white, in contrast to 63% citywide.<sup>1</sup> The difference is largely attributable to the proportionally larger Black population in Alewife than in Cambridge. However, people of color tend to live in specific parts of the Greater Alewife area. For instance, there is a concentration of people of color along the western end of Rindge Avenue. Approximately 31% of Alewife residents were born outside the United States, a figure similar to that of Cambridge overall.<sup>2</sup>

<sup>1</sup> American Community Survey, 2010–2014, 5-year estimates.

<sup>2</sup> Ibid.

### Racial Composition

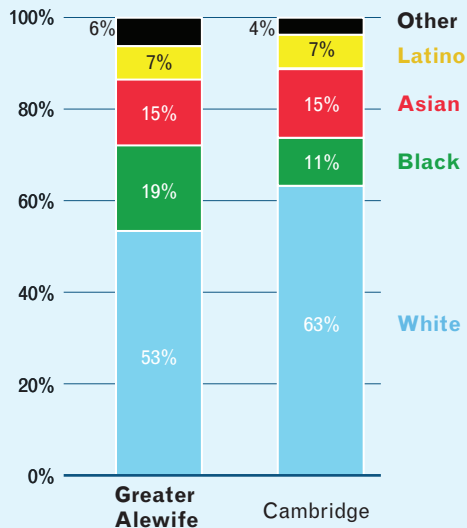

**The population of Greater Alewife tends to be more racially and ethnically diverse than Cambridge generally.**

Source: American Community Survey, 2010–2014, 5-year estimates



Soliciting opinions at the Mobile Engagement Station (July 2016).

**Greater Alewife has proportionally fewer residents with bachelors or advanced degrees than Cambridge as a whole.**

Higher Education Attainment

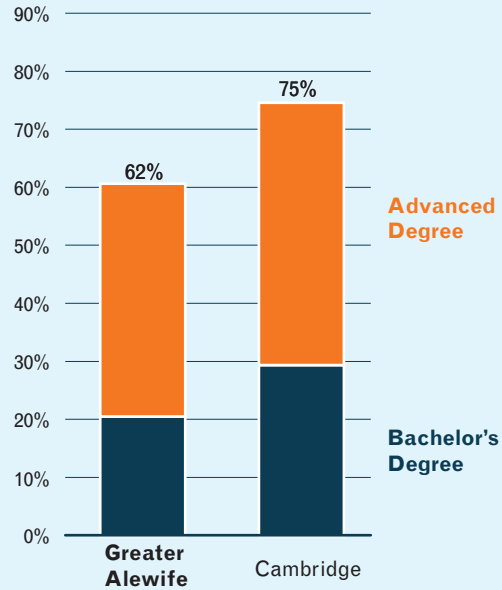

Source: American Community Survey, 2010–2014, 5-year estimates. This sample only includes people 25-years-old or greater.

**Greater Alewife has proportionally more households with very low incomes and fewer households with higher incomes compared to Cambridge overall.**

Household Income Distribution

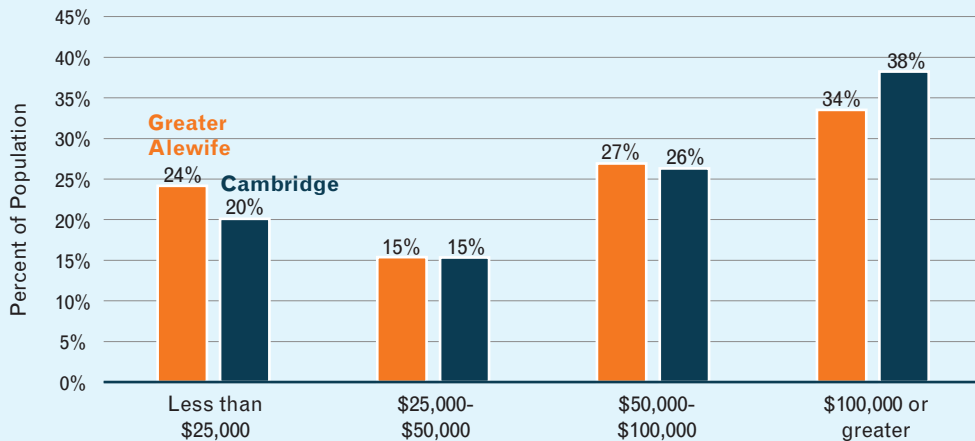

Source: American Community Survey, 2010–2014, 5-year estimates

### Education and Income

Approximately 62% of Greater Alewife’s population holds a bachelor’s degree or advanced degree, compared to 75% in Cambridge overall. Despite this difference, the median income is slightly higher in Greater Alewife (\$79,000) than in Cambridge overall (\$76,000). Furthermore, proportionally more households have incomes below \$25,000 (24% in Greater Alewife versus 20% in Cambridge) and fewer have incomes over \$100,000 (34% in Greater Alewife versus 38% in Cambridge).<sup>3</sup>

### Age, Household Structure, and Household Size

The majority of Greater Alewife’s population (58%) lives in family households, a larger proportion than Cambridge as a whole (48%). This statistic is reinforced by Greater Alewife’s average household size, 2.58 people per household, much larger than that of Cambridge overall (2.00).<sup>4</sup> Greater Alewife’s age structure similarly reflects a large number of families, with a smaller proportion of 18- to 34-year olds than the rest of Cambridge, and proportionally more residents older than 35 and younger than 18.<sup>5</sup>



Danehy Park Day is an event that draws the entire community together and makes use of one of Alewife’s popular public spaces.

### Age Structure

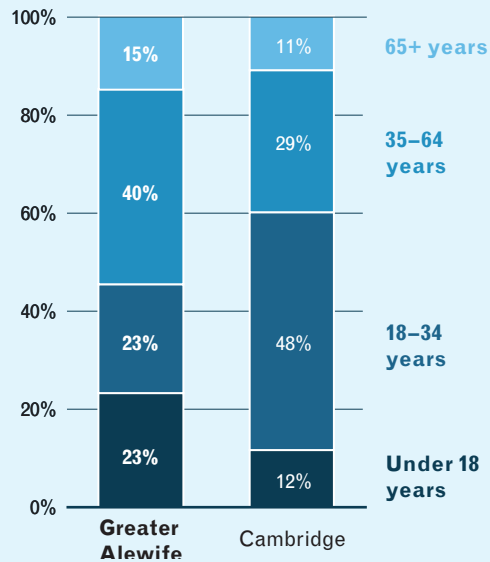

**Greater Alewife’s population has a more even distribution of ages than that of Cambridge as a whole.**

Source: American Community Survey, 2010-2014, 5-year estimates

<sup>3</sup> American Community Survey, 2010-2014, 5-year estimates.

<sup>4</sup> Ibid.

<sup>5</sup> Ibid.



The Alewife Linear Park is a recreational asset that runs through Alewife and connects to several other bike paths.

---

## Population Density

Compared to the rest of Cambridge, Greater Alewife has a low population density — but there is wide variation across the district. The Cambridge Highlands neighborhood, which includes the Alewife Quadrangle, is home to about four residents per acre. In contrast, the area around Rindge Avenue has a density of 75 residents per acre. On average the city is home to 63 residents per acre.<sup>6</sup>

---

## Community Spaces

Community space in Alewife is comprised of both public outdoor green space and indoor gathering spaces. These resources serve different needs and populations, and provide a comprehensive system of places for people to interact, share experiences, and build trust.

Alewife is surrounded by several open spaces and parks, providing passive and active recreation opportunities to city residents and visitors. These public resources include Fresh Pond Reservation, Alewife Brook Reservation, Daney Park, Russell Field, Comeau Field, and McCrehan Memorial Swimming Pool. The Tobin School and the Cambridge Armory offer indoor community space, including locations for public meetings, after school programs, and indoor sports.

Currently, however, Alewife lacks the smaller-scale community open spaces that complement daily city life. The center of Alewife, including the Triangle and Quadrangle, is missing the small neighborhood parks and playgrounds, plazas, and town squares that are typical of Cambridge.

Community-building assets are increasingly important as a means of fostering social resilience and neighbor-to-neighbor support in case of emergency. Providing community space for these networks is one way to promote advanced planning and preparedness.

---

<sup>6</sup> City of Cambridge Neighborhood Statistical Profiles, 2016 (US Census 2010 data).



## Thoughts from the Community: Community Wellbeing

As a result of its auto-centric built form and mobility challenges, parts of Alewife feel isolated from the rest of Cambridge. Despite its shopping destinations, there is no central urban square that promotes walkability and public gathering. This contributes to the public's sentiment that Alewife lacks a strong sense of community. While the district benefits from two large open spaces, Fresh Pond and Danehy Park, and community centers, the presence of congested parkways and suburban-style strip malls inhibit social interaction.

The community commented that they would like additional public spaces, like smaller parks, plazas, and urban streets, as well as libraries, schools, and other community facilities that foster community.

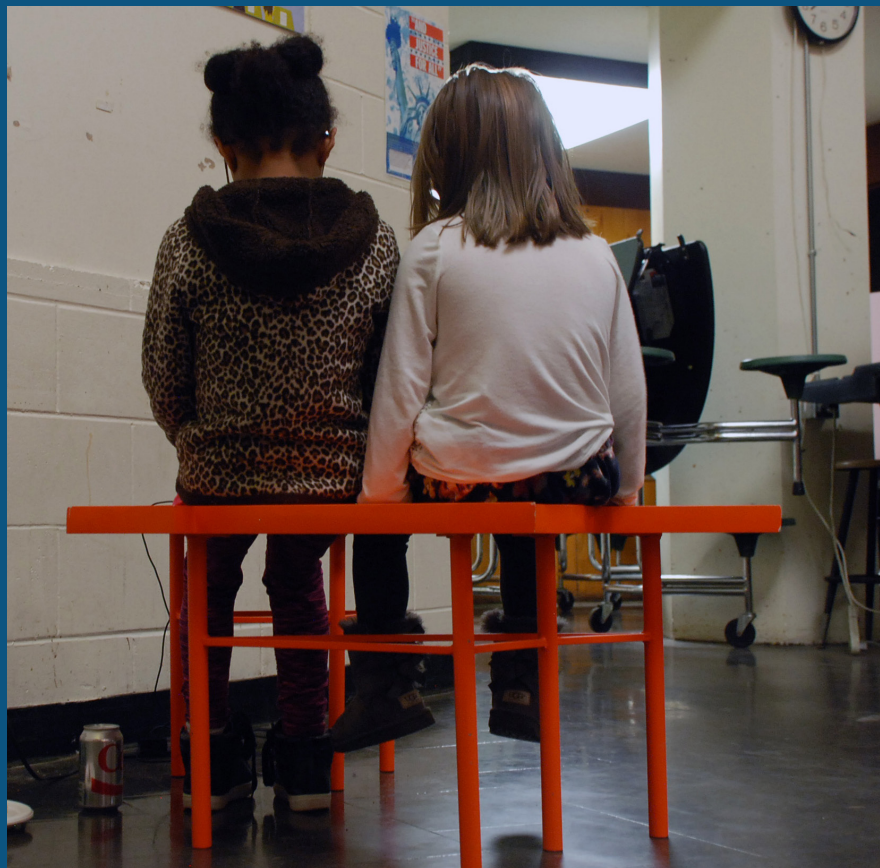

“In the next few decades, I hope Alewife will achieve more of the community feel that embodies the rest of Cambridge.”

— Cambridge resident at the Cambridge Winter Farmers Market, 2017

“Although Cambridge is a community that seems to celebrate and value diversity in many ways, there are still deep racial and class divisions that make it seem more like two cities than one.”

— North Cambridge resident via online survey

“People think livability means retail, but I think it’s actually parks, libraries, museums, churches, schools. Those are the spaces that make a community livable.”

— Cambridge resident at the Cambridge Winter Farmers Market, 2017

# Vision and Goals







# Vision and Goals

**T**he community worked together to create a shared vision for the future of Alewife, focused on transforming it into a vibrant mixed-use district that promotes walkability and increases opportunities for social cohesion. Alewife will be resilient to future climate change impacts and encourage sustainable modes of transportation. Development will promote economic opportunity through the creation of good-paying, low barrier-to-entry jobs, and create additional housing, including affordable housing. This chapter describes the district’s vision and identifies areawide and subdistrict-specific goals. The vision and goals form the foundation upon which the plan’s recommendations are built.

Learn more about . . .

“A Vision for Alewife” on page 94

“Areawide Goals” on page 95

“Subdistrict Goals” on page 97





## A Vision for Alewife

Together, the community crafted a shared vision for Alewife that prioritizes economic opportunity, connectivity, resilience, and social cohesion. This vision reflects a continued and collective desire to establish a strong sense of place in Alewife through a mix of uses, including a range of housing and job options, retail and open space, and public amenities.

Central to Alewife's future will be a balanced economy that welcomes new industries, while preserving and fostering existing ones. Light industrial businesses continue to be central to Alewife's history and identity. The vision aims to preserve and revitalize light manufacturing to diversify the economy and create pathways to good-paying jobs. In order to create a thriving Alewife, economic growth will be balanced with housing that offers a range of types and levels of affordability.

The envisioned mixed-use district includes amenities, such as open space, local retail, and community facilities to foster social ties and improve connections between Alewife and the adjacent neighborhoods and open spaces. The urban form of Alewife and the provision of daily needs and destinations will promote walking, biking, and transit use, in turn reducing the growth in vehicle miles traveled (VMT) for a more sustainable Cambridge.

Alewife will include a variety of building types that frame parks and civic spaces to further establish a sense of community and provide areas for gathering. Its urban form will also be responsive and resilient to the impacts of climate change. Resilience strategies will enhance the urban environment through sustainable infrastructure solutions. Preparing for climate change will allow Alewife to thrive for generations to come.



## Areawide Goals

The community developed areawide and sub-district goals to realize the shared community vision. Areawide goals are collective aspirations for the entire district while subdistrict goals recognize the distinct character of specific areas. Combined, the goals support the overall vision for Alewife.

### Build a Cohesive Mixed-Use District.

Transform Alewife into a fully functioning urban neighborhood with a broad range of uses and a variety of public places that provide opportunities for social connection and interaction.

### Integrate Alewife with the Rest of Cambridge.

Better integrate the district physically and socially with the surrounding neighborhoods and the rest of the city for a greater sense of community.

### Promote Economic Opportunity

Support commercial and light industrial development that provide high-wage, low barrier-to-entry jobs.

### Create a District Resilient to the Impacts of Climate Change.

Ensure that new development and existing neighborhoods, community resources, and critical infrastructure are prepared for climate change and resilient to its impacts.

### Enhance the Public Realm

Create an active, resilient urban form that promotes activity on the street.

### Encourage Sustainable Modes of Transportation.

Promote walking, biking, and transit use and reduce the growth in vehicle miles traveled.

### Create a Continuous Open Space & Recreation Network.

Increase the quantity, quality, and diversity of open spaces across the Alewife district and create an interconnected recreation network.

## Community Vision

Alewife is a sustainable, resilient, mixed-used district with convenient and safe connections within the neighborhood and to the rest of the city along with amenities that support interaction and social ties among its residents.



- Cambridge City Line
- - - Subdistrict



## Subdistrict Goals

### Quadrangle Goals

- Preserve and enhance light industrial businesses, and community-focused businesses that require light industrial space, that provide good-paying, low-barrier-to-entry jobs.
- Create a significant new linear open space and smaller open spaces internal to blocks.
- Create a “Main Street” on Wilson Road with active ground-floor uses, including showrooms or retail space for light industrial uses.
- Create a connected network of streets and pathways
- Encourage a variety of housing types including townhouse and live-work units
- Maintain the stability and character of the Cambridge Highlands neighborhood.
- Encourage small-scale neighborhood supporting retail on Concord Avenue and Smith Place.

### Shopping Center Goals

- Create an “Alewife Square” that parallels the historic urban centers that characterize much of Cambridge.
- Create a walkable shopping destination that includes mixed-use residential development and active ground floor space.
- Transform Alewife Brook Parkway into an urban street framed by architecture, retail, and generous pedestrian and bicycle facilities.
- Eliminate surface parking and improve circulation within the Shopping Center through a clearly visible roadway system.

### Fresh Pond Parkway Goals

- Encourage mixed-use residential development with active ground floor space along Fresh Pond Parkway.
- Improve public open space connections between Fresh Pond and Danehy Park.

- Preserve the existing residential character of the neighborhood.
- Ensure that the scale of new peripheral development is sensitive to abutting neighborhoods.

### Whittemore Avenue Goals

- Encourage commercial use along Alewife Brook Parkway.
- Encourage mid-density residential development adjacent to the existing residential neighborhood.
- Incentivize development to invest in open space improvements in and around Jerry’s Pond.
- Create new multi-use path connections from Whittemore Avenue and the Linear Park to the Alewife MBTA station.

### Triangle Goals

- Maintain its mixed-use character.
- Promote retail and active space on Cambridgepark Drive.
- Improve the urban form of the area through streetscape improvements.
- Improve bicycle and pedestrian connections.



Preserving light industrial businesses is a goal for the Quadrangle.

# Recommendations





# Recommendations

The Alewife District Plan identifies actionable recommendations to transform the district into a vibrant, mixed use neighborhood. Recommendations include zoning changes, design guidelines, and infrastructure improvements across seven planning topics: Land Use, Open Space, Urban Form, Mobility, Climate and Environment, Housing, and Economy. For each planning topic, areawide and subdistrict specific recommendations are provided.

Learn more about . . .

“Land Use” on page 102

“Open Space” on page 108

“Urban Form” on page 114

“Mobility” on page 124

“Climate and Environment” on page 134

“Housing” on page 144

“Economic Development” on page 148

“Zoning” on page 154

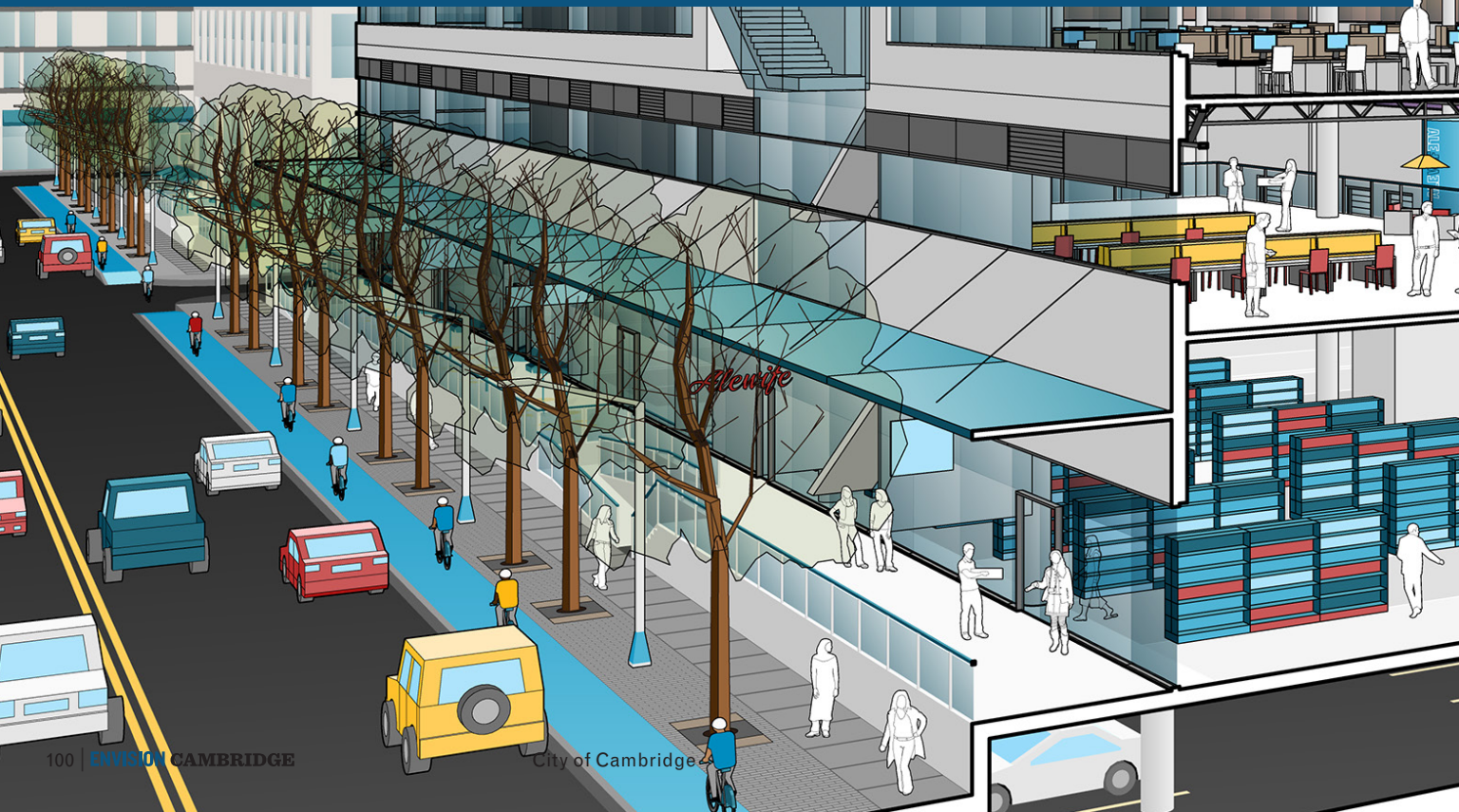

# Alewife

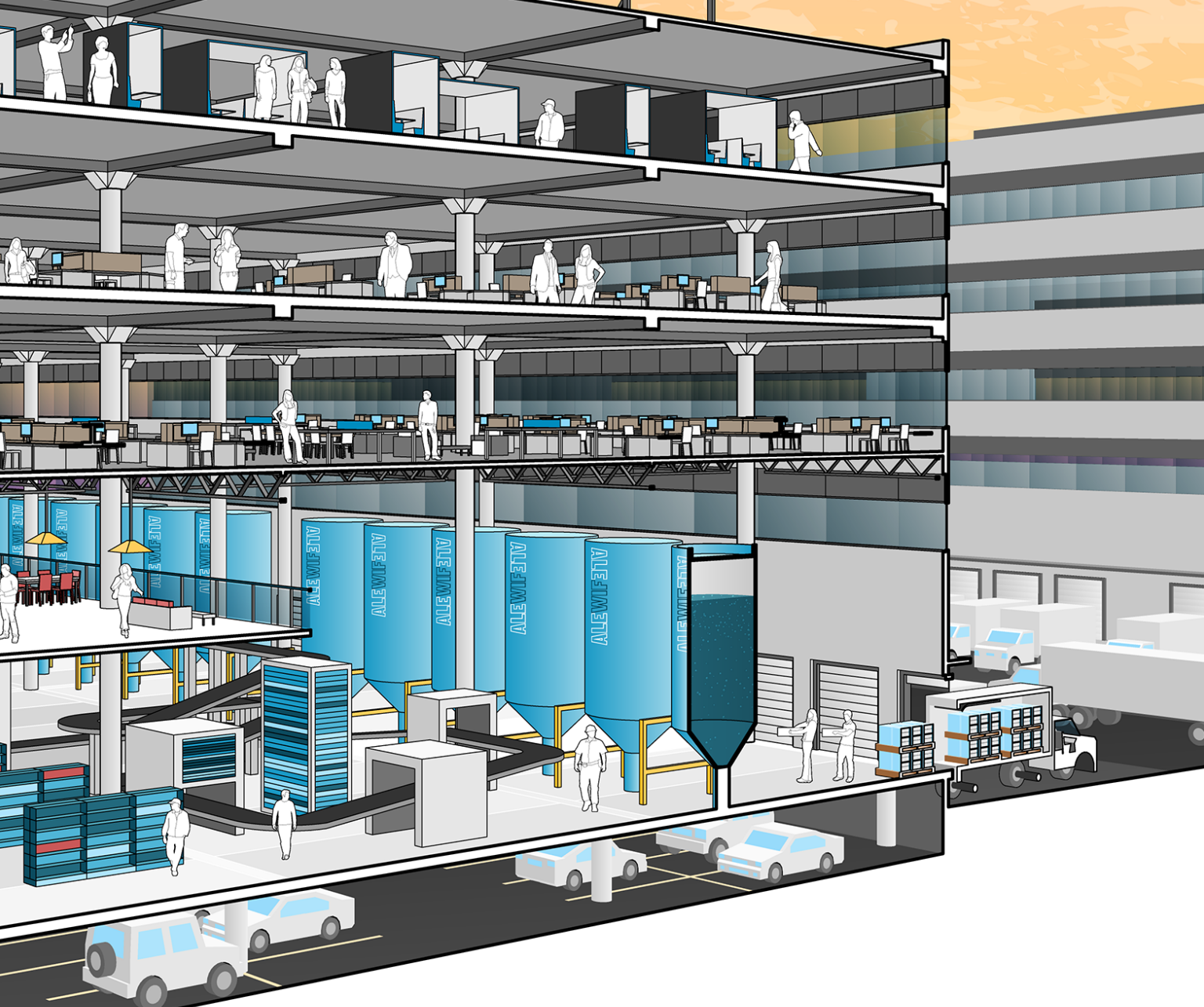



---

## Land Use

A key component of this plan is a new land use pattern, informed by scenario analysis and work with community stakeholders. [Read more about this process in “Scenarios” on page 31.](#) Introducing a more balanced mix of land uses will enhance Alewife’s local character and result in a more walkable neighborhood. As Alewife grows, public amenities such as libraries, community centers, and indoor publicly-accessible spaces should complement private development.

Each subdistrict has a unique land use strategy intended to enhance its identity and aid in addressing existing areawide and subdistrict challenges. The Quadrangle subdistrict has the most diverse land use pattern, introducing new mixed-use light industrial buildings alongside a mix of residential and commercial space. [Read more about the light industrial mixed-use building type in “Mixed-Use Industrial” on page 121.](#) The Quadrangle has the highest likelihood for change, and will require careful consideration of how to retain light industrial uses as it transforms.

In contrast, the Shopping Center subdistrict is already a commercial hub. This plan envisions the Shopping Center subdistrict as a walkable environment that incorporates residential development above ground floor commercial activity.

Most of the sites in the Triangle are already developed with commercial and residential buildings. As the remaining sites are redeveloped, this mixed-use pattern should continue, and the amount of ground-level retail should be increased.

The land use plan for the Fresh Pond Parkway subdistrict intends to activate the Parkway through ground-floor uses while preserving the existing residential character of the adjacent neighborhood.

Lastly, the plan recommends the Whittemore Avenue subdistrict become primarily a mid-density residential area, relocating commercial use near Alewife Brook Parkway as a cap to the Route 2 corridor and using open space within the subdistrict to enhance and connect existing neighborhoods.

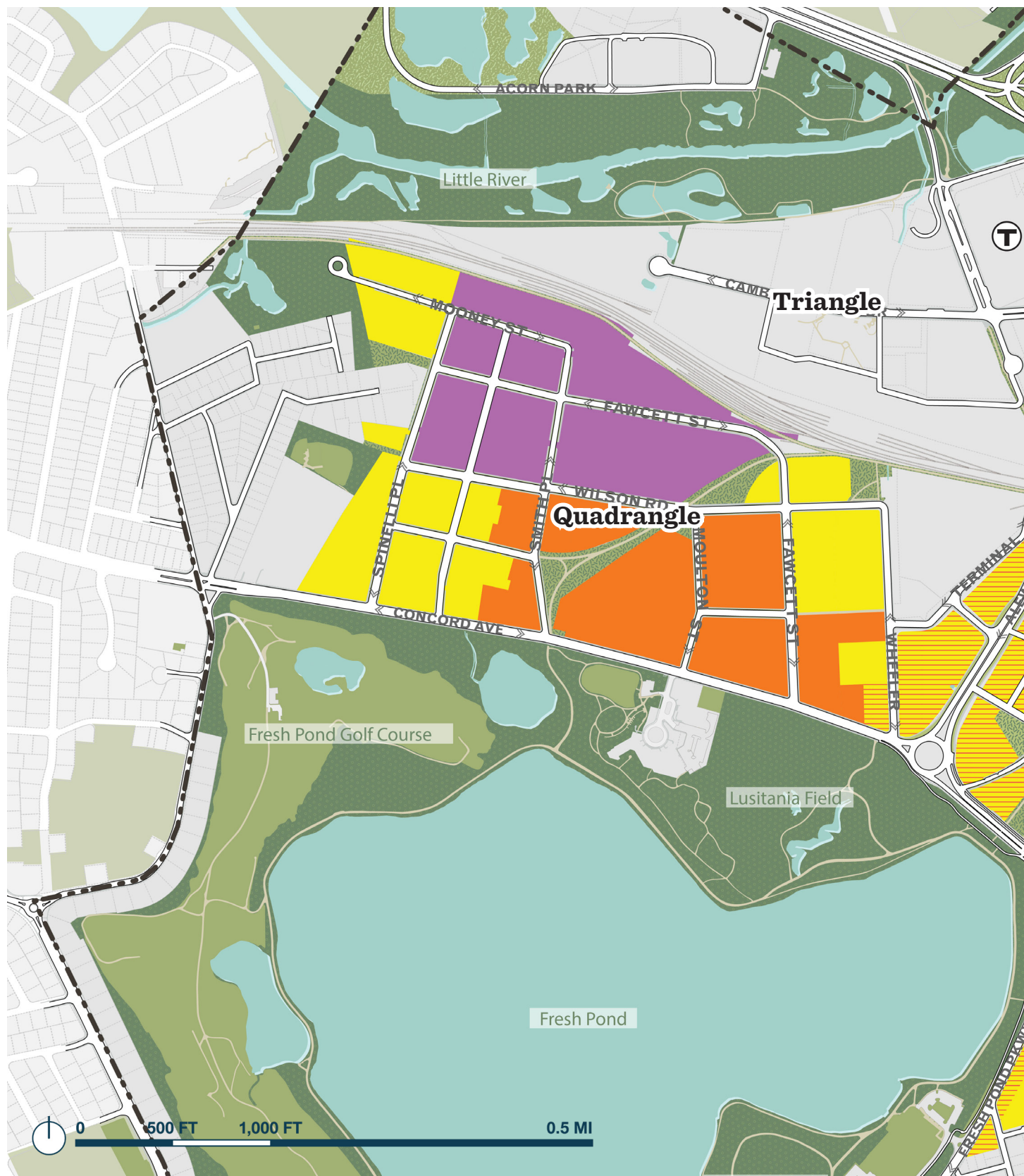



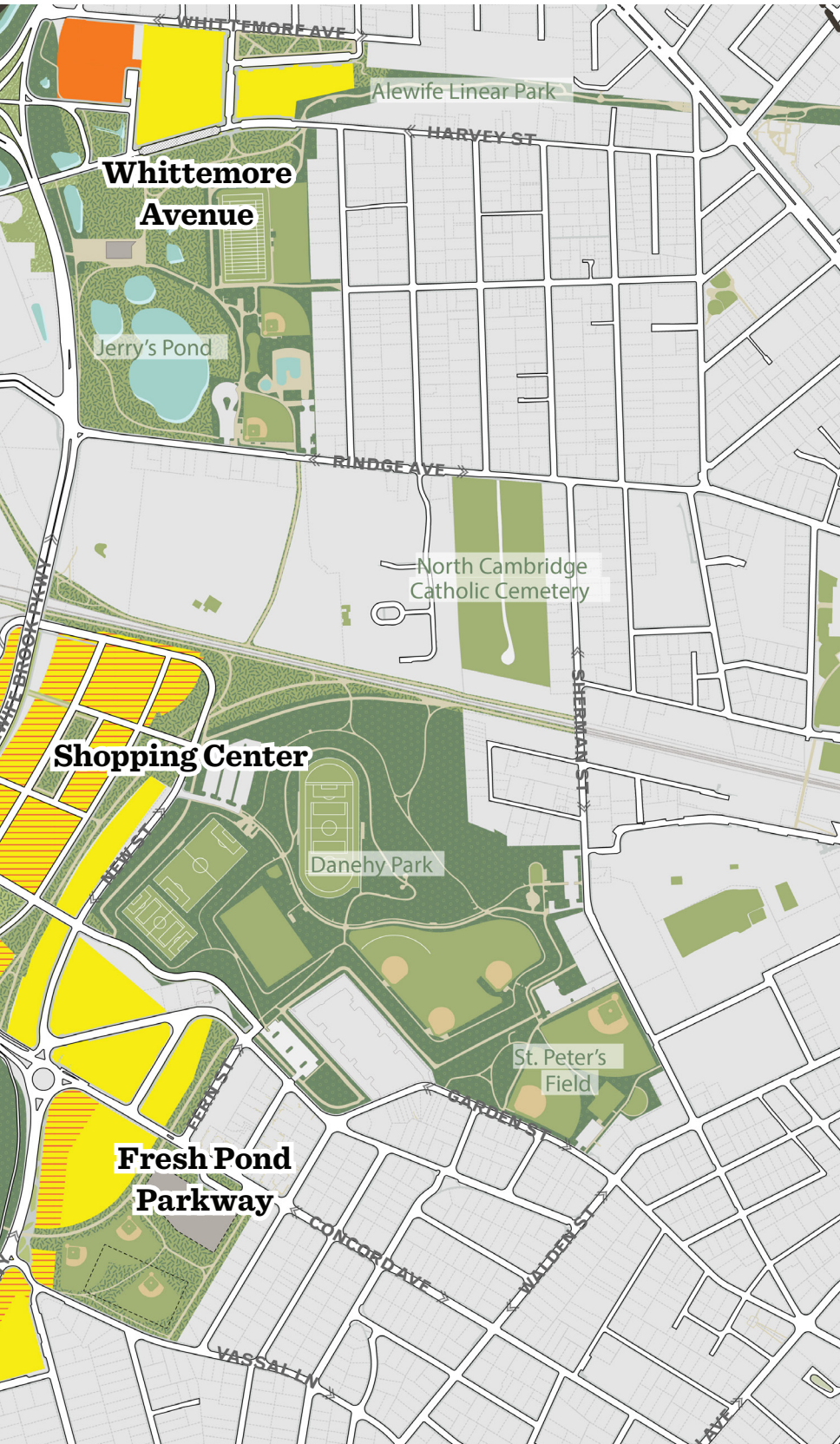

### Proposed Primary Land Use

This map identifies the primary land uses envisioned for the sub-districts; however, other uses are allowed in all of them.

- General Mixed-Use
- Residential
- Residential with Ground Floor Retail
- Commercial with Ground Floor Light Industrial
- Open Space

## Land Use Recommendations

The primary goal of the land use plan for Alewife is to create a mixed-use district with a distinct sense of place that is conducive to an enriching and enjoyable life for its residents and workers. By introducing a significant amount of housing, commercial and light industrial space, and retail, the City can enhance the area's appeal for working, shopping, and living.

## Areawide Recommendations

### Mixed-Use Urban District

- Introduce a greater mix of uses across the district and promote a variety of building types.
- Concentrate retail on primary streets, parkways, and public squares to create walkable neighborhood destinations.
- Create an environment with sufficient residential and commercial density to support retail and civic institutions typical of a thriving urban neighborhood.
- Encourage mixed-use buildings that combine retail, office, and residential uses to create an urban environment that provides easy access to daily needs and amenities.
- Leverage development to create open space and public amenities such as a library, community center, or recreation center to foster a sense of community in residential portions of Alewife.
- Facilitate more walking, biking, and transit use, and minimize the growth of vehicular trips, through the location of buildings, mix of uses, and public realm improvements.
- Encourage low- to mid-density residential development to buffer existing neighborhoods, such as Cambridge Highlands and residential areas near Whittemore Avenue and Fresh Pond, from commercial uses.



Mid-density residential development can provide a gentle transition to abutting residential neighborhoods and provide the necessary housing for a true urban district.

## Subdistrict Recommendations

### Quadrangle

- Direct low- to mid-density housing in the southwest corner of the Quadrangle adjacent to Cambridge Highlands.
- Create a green buffer on the western edge of the Quadrangle to buffer Cambridge Highlands from light industrial uses.
- Create a “Main Street” along Wilson Road as the civic center of the light industrial area to accommodate active ground floor uses, including showrooms for fabrication spaces.
- Preserve light industrial uses in the northwest corner of the Quadrangle.
- Increase access to more goods and services locally to animate the neighborhood throughout the course of the day.
- Encourage commercial development along Smith Place south of Wilson Road
- Locate small scale neighborhood retail on Concord Avenue and Smith Place.

### Shopping Center

- Promote mixed-use development with ground floor retail space.
- Require the provision of a retail space that can accommodate a large grocery store.
- Create a “Main Street” for the subdistrict that facilitates walking and socializing while supporting small-scale retail businesses.
- Create an “Alewife Square” as the centerpiece of the retail development and connection point to the enhanced open space network.
- Replace surface parking with structured parking wrapped with ground floor retail on primary facades and residential or office space on upper floors.
- Consolidate parking in shared garages

through new multifamily and mixed-use building prototypes.

- Concentrate lower-density residential buildings around Danehy Park and on Concord Avenue, while concentrating high density buildings closer to Alewife Brook Parkway.

### Whittemore Avenue

- Mark the western gateway into the city through a landmark commercial development located at the terminus of the Concord Turnpike.
- Transform the commercial area between Whittemore Avenue and Harvey Street into a mid-density residential area.
- Locate parking behind buildings, so that it is not visible from the adjacent neighborhoods, streets, and open spaces.
- Concentrate commercial office uses on the western edge of the subdistrict.

### Fresh Pond Parkway

- Redevelop commercial sites with frontage on Fresh Pond Parkway as mixed-use residential buildings with ground-floor retail or active space.
- Create a buffer between the Parkway’s commercial activity and existing neighborhoods with residential-only buildings just east of the proposed mixed-use residential buildings. This includes the area along Worthington Street and Lakeview Avenue.
- Propose a linear open space connection between Concord Avenue and Fresh Pond Parkway.
- Avoid siting parking in locations visible from streets or public open spaces.

### Triangle

- Promote mixed-use development with active ground floor uses.



---

## Open Space

There is a need to increase access to open space in Alewife. This can be accomplished by creating a network of high-quality open spaces of varying size and character that fulfill a range of functions on both privately-owned and publicly-owned land. Expanding the existing open space network will have multiple benefits, including reducing heat and flooding impacts, improving connectivity across and within Alewife, providing alternatives to car travel, and increasing health and wellness of residents and workers. Together, these benefits enhance the livability of the district.

The plan improves connectivity through the district by creating a network of streets, parks, and squares. This network will link Alewife to surrounding parks, and increase the amount of land dedicated to public open space. The Quadrangle's three-acre linear open space on the former railroad right-of-way is the most dramatic proposed open space transformation, and it will serve as an amenity and catalyst for future development of the Quadrangle. As designed, it provides a quarter-mile bike and pedestrian path, connecting the Concord Avenue separated bike lane and Fresh Pond to Terminal Road and the Shopping Center.





### Proposed Open Space Plan

The proposed open space network connects existing open space resources such as Danehy Park, Fresh Pond, and the Alewife Linear Park with proposed parks, plazas, and paths throughout the district.

- Proposed Open Spaces/Paths
- - - Cambridge City Line

## Open Space Recommendations

An open space system in Alewife should connect people to key destinations, including community facilities, shopping, and open space resources. The primary district objective is to provide a variety of public spaces including plazas, parks, and paths that create a more complete and continuous open space and recreation network.

### Areawide Recommendations

#### Open Space & Recreation Network

- Establish a network of high-quality open spaces of varying size, character, and function that link to existing open spaces.
- Better integrate the district, internally and with the rest of the city, through new streets, walking and biking paths, and open spaces.
- Connect Alewife's streets, paths, parks, squares, and courtyards with one another.
- Expand off-street connections to existing open spaces by introducing new open spaces.
- Extend the open space network to complete the circuit from Fresh Pond to Danehy Park.
- Ensure that public open spaces provide facilities for people of all ages and abilities.

#### Public Spaces

- Encourage the creation of public and private courtyards to offer a variety of types of spaces, conducive to different uses.
- Work with the private sector to ensure delivery of new open spaces over time.
- Create distinct places that will offer a wide range of possibilities for lively urban streets, quiet residential streets, public open spaces, residential courtyards, and public squares.
- Incorporate a wide range of types of public places, suitable for uses including active and passive enjoyment, informal gatherings, play, and organized events
- Design public open spaces to meet the needs of nearby residents and workers.

#### Resilience

- Maximize green infrastructure in new development and in public rights-of-way.
- Utilize new public and private open space for resiliency and preparedness by increasing stormwater management and storage capacity across the district.
- Increase tree canopy and shading throughout the district.

### Subdistrict Recommendations

#### Quadrangle

- Build new open space connections to Rafferty Park.
- Construct a linear open space on the former railroad tracks.

#### Shopping Center

- Create an urban square as the centerpiece of the retail development and the connection point to the enhanced open space network.

#### Whittemore Avenue

- Incentivize development to invest in open space improvements in and around Jerry's Pond.
- Improve the connection to the Alewife Linear Park at Jerry's Pond by realigning the route around the existing path.
- Expand the existing open space east of Alewife Brook Parkway and north of the MBTA station headhouse by converting the existing parking lots for Alewife Center to open space.
- Create a more direct and active connection between the Alewife Linear Park and the Alewife MBTA Red Line station.
- Use open space to connect new residential development to existing neighborhoods.
- Create a small neighborhood park along the south side of Whittemore Avenue to manage stormwater during flood events.



- Consider enhanced open spaces, including berms in strategic locations, as a means to decrease the risk of flooding due to the proximity to Alewife Brook and the Mystic River watershed

### Fresh Pond Parkway

- Connect Callahan Playground to the larger open space network during the future Tobin School reconstruction project.
- Evaluate stormwater storage options at the Tobin School to provide increased resilience for extreme precipitation events.

### Triangle

- Improve pedestrian and bicycle infrastructure on both streets and privately owned driveways.
- Plant street trees.
- Create additional multi-use paths to Alewife Brook Reservation.



The conceptual illustration shows the proposed green linear open space in the Quadrangle, stretching from the proposed pedestrian/bicycle bridge to Fresh Pond. This open space link will benefit connectivity, stormwater mitigation, and overall quality of life.



GR  
52

---

## Urban Form

Well-designed and varied buildings, streets and open spaces work together to create a welcoming and pleasant public realm. The urban form recommendations in this plan include areawide and subdistrict-specific design guidelines to create a lively, walkable urban center that adapts to, and mitigates, climate change impacts.

Design guidelines aim to define streets and public spaces by configuring buildings to create urban blocks with a continuous street edge. Long facades should be punctuated with interesting architectural elements. Publicly accessible parks, open spaces, and plazas should provide connections, shading, and places for the community to gather. A varied public realm creates a more dynamic pedestrian experience and strengthens the social fabric within the district.

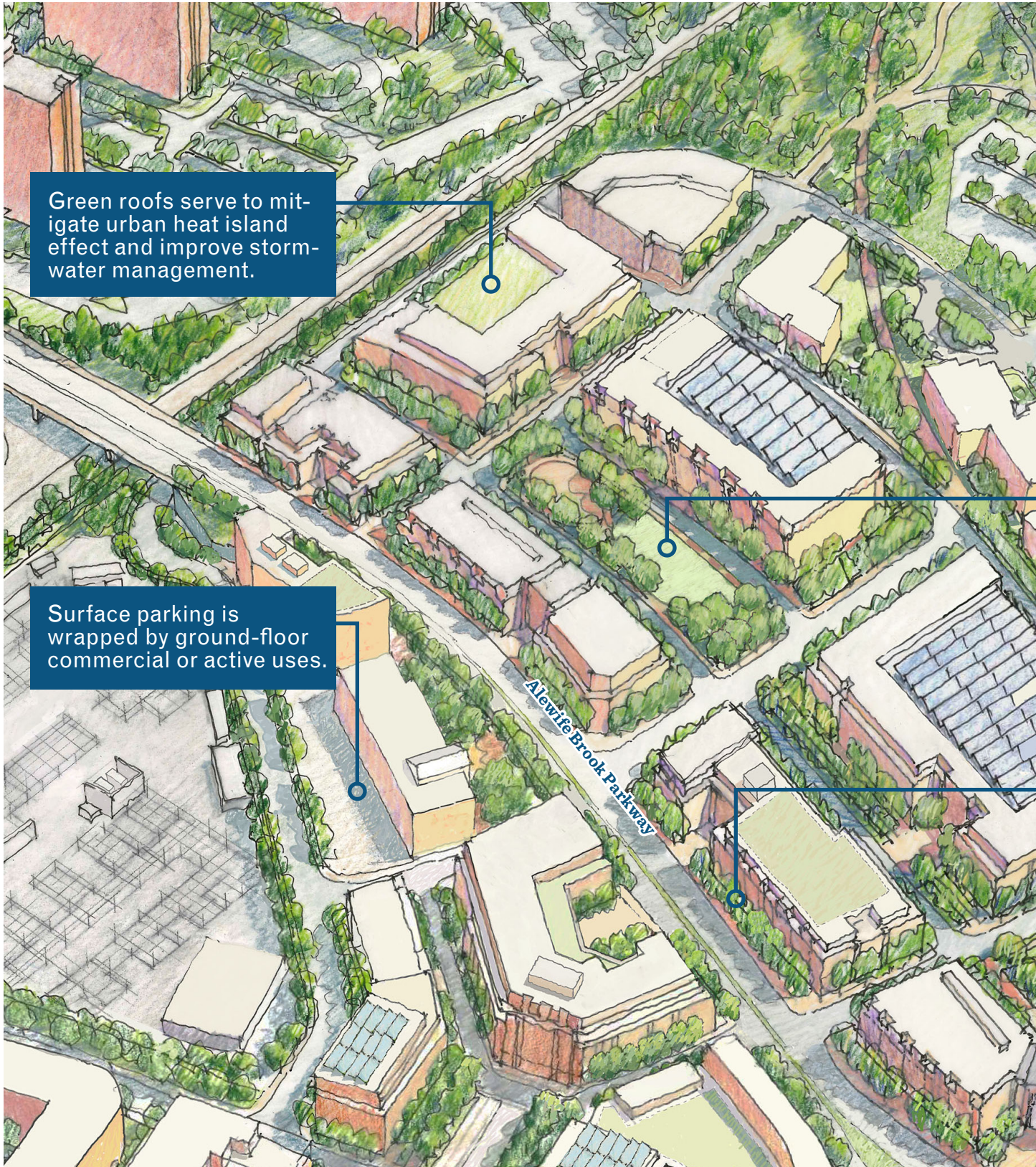

Green roofs serve to mitigate urban heat island effect and improve storm-water management.

Surface parking is wrapped by ground-floor commercial or active uses.

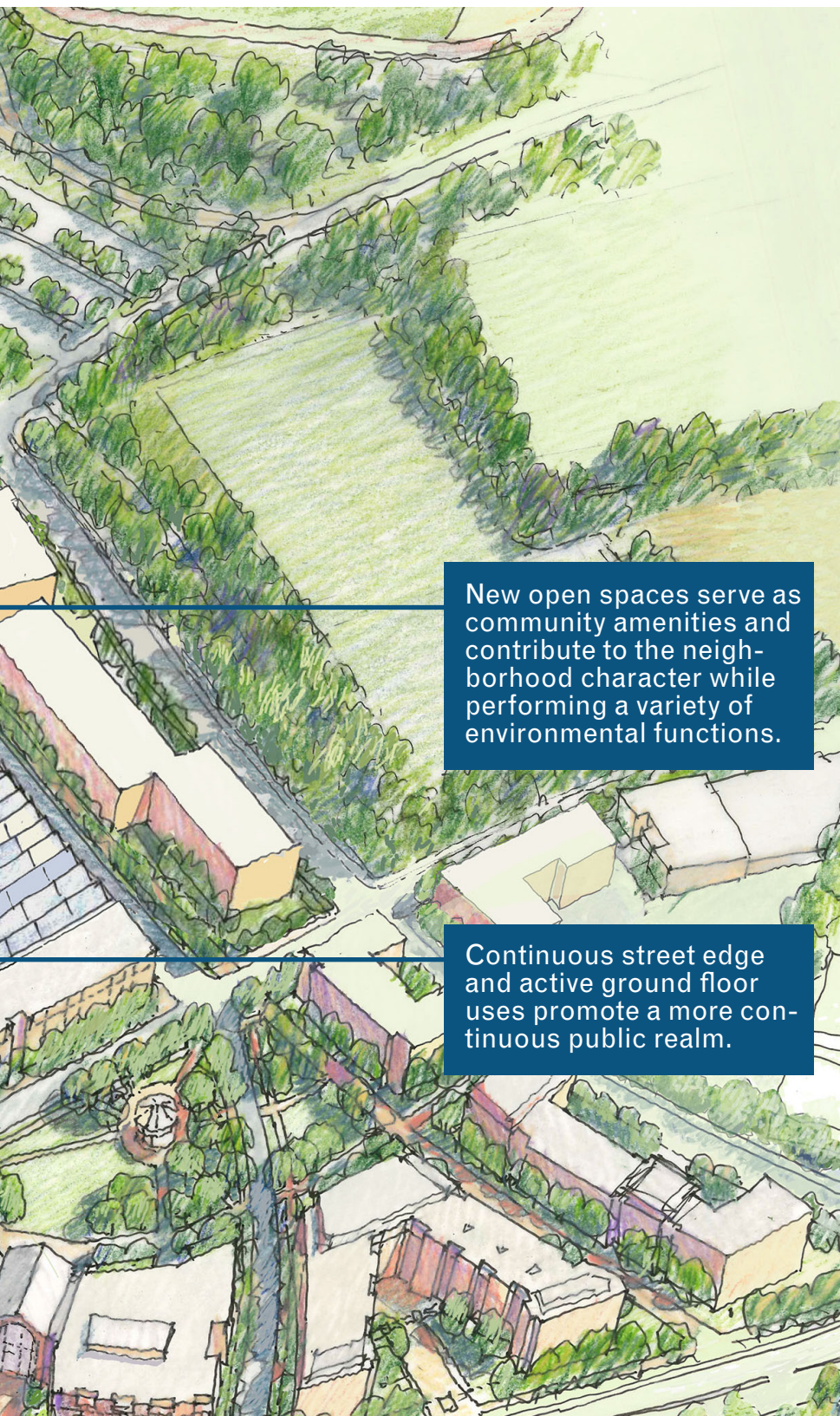

New open spaces serve as community amenities and contribute to the neighborhood character while performing a variety of environmental functions.

Continuous street edge and active ground floor uses promote a more continuous public realm.

A conceptual aerial view of development in the Shopping Center subdistrict illustrates many of the urban form recommendations for Alewife, such as creating new main street conditions, reorienting the urban form to the pedestrian scale, and increasing pervious surfaces through rear setbacks and green roofs.

## Urban Form Recommendations

As part of the Alewife Planning Study, Alewife Design Guidelines were created to guide development in the district. They identify site and building design, built form, and open space measures to realize the district’s urban form vision. They will inform property owners, business owners, developers, and the general public about the desired form and character of development in Alewife and will be used by the Planning Board in their review of discretionary permits in the Alewife area. The following section summarizes the Alewife Design Guidelines.

## Areawide Recommendations

### Site and Building Organization

- Define streets and public spaces by orienting and configuring buildings to create urban blocks with a continuous street edge.
- Break down the bulk of buildings by limiting the length of facades.
- Break large blocks into a system of smaller blocks to improve pedestrian, bicycle, and vehicular circulation.
- Use site design to preserve, improve, and create the rights-of-way identified in this plan.
- Locate entrances on primary streets and loading areas on secondary streets and alleys.
- Minimize intrusion of vehicle entries, drive-ways, and utilities on the public realm.
- Consolidate parking, loading, service roads, and fire lanes.



Assembly Square, a mixed-use development in neighboring Somerville, is an example of the pedestrian-oriented development and open spaces that are envisioned for the Shopping Center.

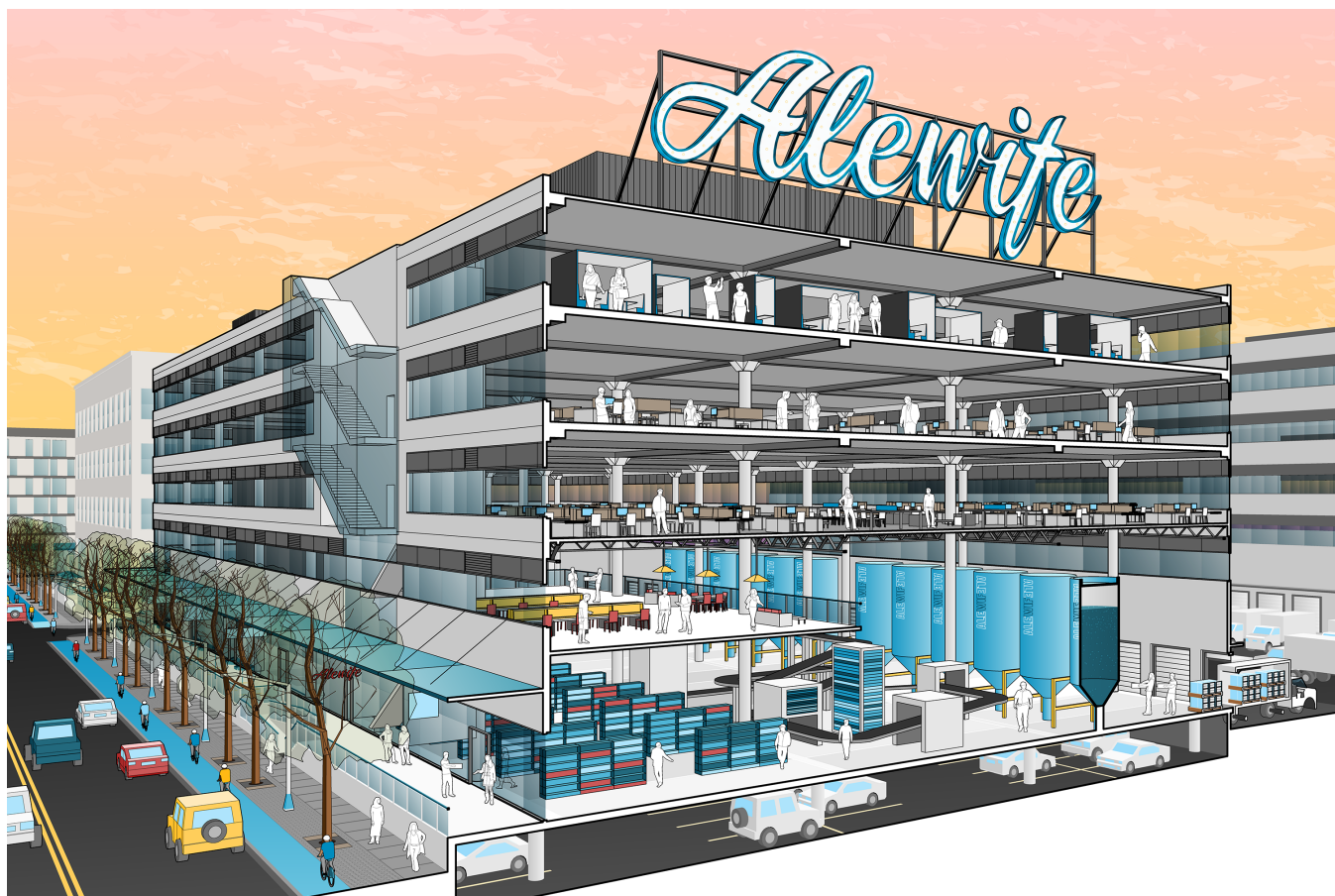

The light industrial mixed-use prototype for the Quadrangle promotes preservation of Alewife's existing industrial economy.

- Eliminate on-site surface parking to the greatest extent possible. Any above-grade parking on private property should be hidden from public view and wrapped with active uses where they meet the public street.

### Built Form

- Introduce a variety of building types to provide a mix of uses and increase street activity. *Read more about proposed building types in “Building Types” on page 120.*
- Create active ground floors with multiple building entrances.
- Frame and define public space with street-wall facades.
- Articulate facades and break down the

massing of tall buildings to reduce their visual bulk.

- Use high quality, durable, and sustainable materials.
- Encourage the incorporation of artwork within private development
- Promote energy efficiency in building design and infrastructure.
- Require new development to prepare for future flooding and extreme heat.
- Elevate first floors to protect buildings from the 2070 10-yr sea-level rise plus storm surge (SLR/SS) flood elevation and recover from the 2070 100-yr SLR/SS flood elevation; allow only non-conditioned uses and parking below the elevated first floor.

## Building Types

This plan recommends a variety of building types in Alewife to enhance the district’s mixed-use character. A combination of these types should be introduced in Alewife’s subdistricts to vary its built form. The precise mix of types encouraged in each subdistrict will contribute to the distinct character of each subdistrict, and complement adjacent residential communities.

### Land Use

- Commercial
- Residential
- Active Use
- Industrial

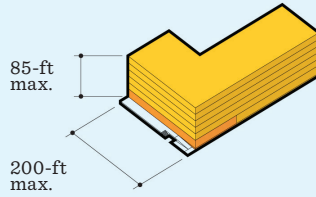

### Mixed-Use Residential

Mixed-use residential buildings are located on streets with a “Main Street” character. They contain multifamily housing on upper floors and active uses like retail on the ground floor. If the building extends back from the primary street in an “L” shape or similar formation, the ground floor along the back portions contains ancillary uses (such as lobbies and laundry rooms) rather than housing. Residential units will be elevated to reduce the risk of flooding. Parking is located underneath the ground level and accessed from the rear of the property.

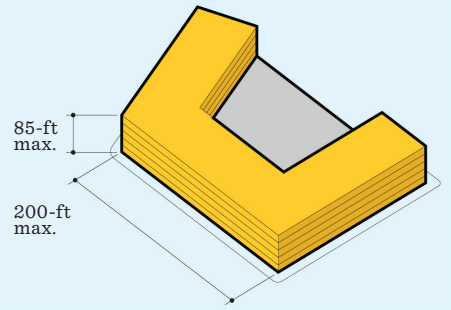

### Mid-Density Multifamily

Mid-density, multifamily residential buildings without commercial uses should be concentrated near existing residential neighborhoods. Housing units are located on upper floors, while ancillary uses are located on the ground level. Parking should be located behind the building under a covered parking deck.

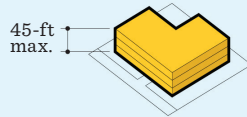

### Low-Density Multifamily

Low-density, multifamily residential buildings contain three stories of housing units, complementing the scale of development on Concord Avenue and elsewhere. This building type should be used where continuity with existing neighborhoods is a priority.

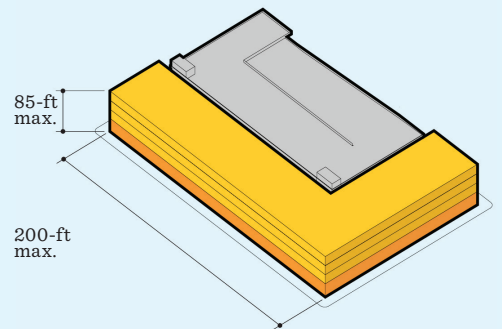

### Mixed-Use Residential with Garage

Where appropriate, development should adopt shared parking for multiple buildings in a garage. The garage should be wrapped with active ground floor uses with residential space above so that the street remains engaging and the amount of garage facade is minimized.



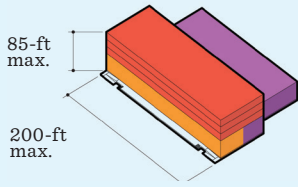

### Mixed-Use Industrial

Mixed-use industrial buildings should be located near the north-western edge of the Quadrangle subdistrict. This building prototype contains a double-height ground level for industrial use, fronted by accessory retail uses along retail corridors (where appropriate). Three stories of office use should be located above the ground level. Retail should face an elevated walkway on appropriate streets, with loading and logistics in the rear of the building.

**A variety of building types can enhance the public realm while introducing a mix of uses throughout the district.**

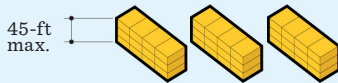

### Townhouse

Townhouses are attached single-family homes of a scale complementing the urban fabric of the Cambridge Highlands neighborhood. Townhouse development maintains relatively high residential density while offering the privacy and amenity of single-family homes. In Alewife, the first habitable floor of townhouses is raised to protect from flooding.

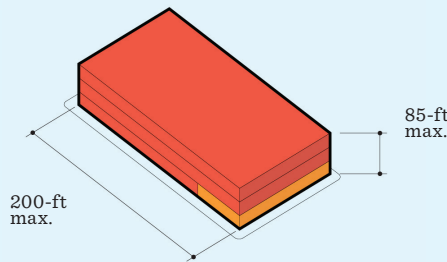

### Mixed-Use Commercial

Mid-density, mixed-use commercial buildings should contain office or laboratory uses on upper floors with ground floors split between active uses fronting retail streets and office or laboratory uses towards the rear of the property.

## Open Space

- Create new streets and paths to create a connected network and break up large blocks.
- Design streets to accommodate all modes.
- Design open spaces for universal access.
- Design privately-owned public spaces so they are perceived as fully accessible public space.
- Plant continuous shade trees along streets and within and around service areas, parking lots, and other paved areas.
- Maximize space for continuous tree canopy by concentrating open space in the interiors of blocks, rather than providing narrow strips of open space around the edges of parcels.
- Maximize permeable surfaces on portions of parcels not occupied by buildings.
- Utilize green infrastructure to reduce flooding impact from smaller rainfall events and to mitigate the urban heat island effect.
- Incorporate public art in public spaces

## Subdistrict Recommendations

### Quadrangle

- Elevate first occupiable floors.
- Design light industrial buildings with double-height ground floors for fabrication space and appropriate floor plate depths on the upper floors to accommodate commercial uses, such as office and research and development.
- Create a green buffer between the Cambridge Highlands and the Quadrangle.
- Transform Concord Avenue into an urban boulevard lined by street trees, generous pedestrian sidewalks, landscaped setbacks, and courtyards.
- Frame the proposed diagonal linear open space with building facades and multi-use paths.
- Connect the proposed diagonal linear open space to adjoining paths and open spaces in the district where possible.

## Shopping Center

- Create new open spaces including a central public square.
- Encourage shared parking in the rear of parcels and wrap parking garages with active uses where they meet the public street.
- Provide Alewife Brook Parkway with generous sidewalks, curbside street trees, street-wall buildings, and active ground floor uses.

## Whittemore Avenue

- Extend Harvey Street as a multi-use path to the Alewife MBTA station.
- Incentivize development to invest in open space improvements in and around Jerry's Pond.

## Fresh Pond Parkway

- Locate and configure buildings to create streetwalls along Fresh Pond Parkway, Lexington Avenue, and Lakeview Avenue.

## Triangle

- Transform privately owned driveways into pedestrian friendly streets.
- Provide Alewife Brook Parkway with generous sidewalks, curbside street trees, street-wall buildings, and active ground floor uses.

## Illustrative Examples of the Impact of Urban Form Regulations

Arranging new development in perimeter blocks can better define the public realm by screening parking and concentrating active uses along the sidewalk, creating a more cohesive and intimate pedestrian environment.

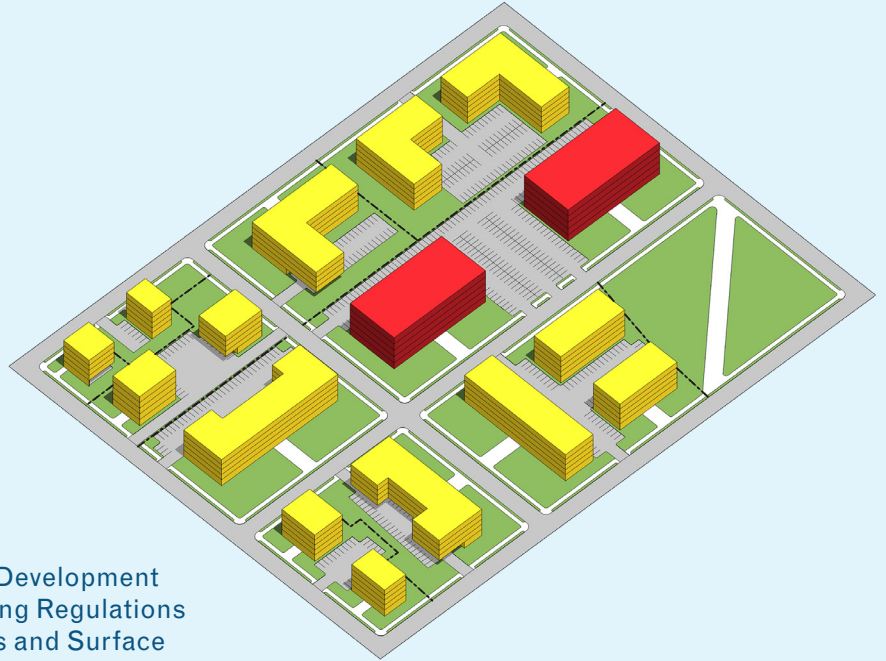

Example of Development under Existing Regulations for Setbacks and Surface Parking

Surface parking is wrapped by ground-floor commercial and active uses, and covered by a landscaped deck.

Continuous street edge and active ground floor uses promote a more continuous public realm.

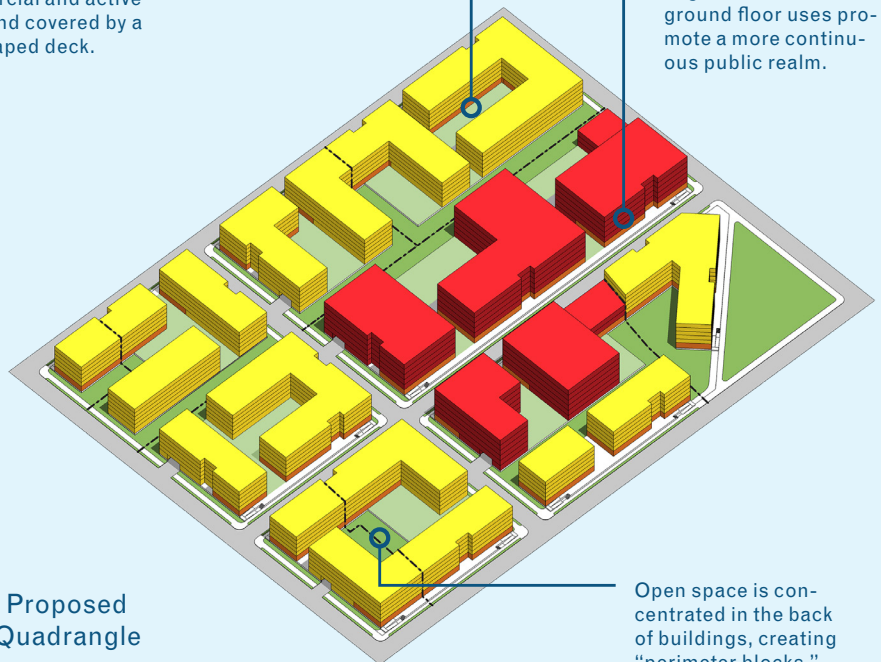

### Land Use

- Active Uses
- Commercial
- Residential

Example of a Proposed Block in the Quadrangle

Open space is concentrated in the back of buildings, creating "perimeter blocks."

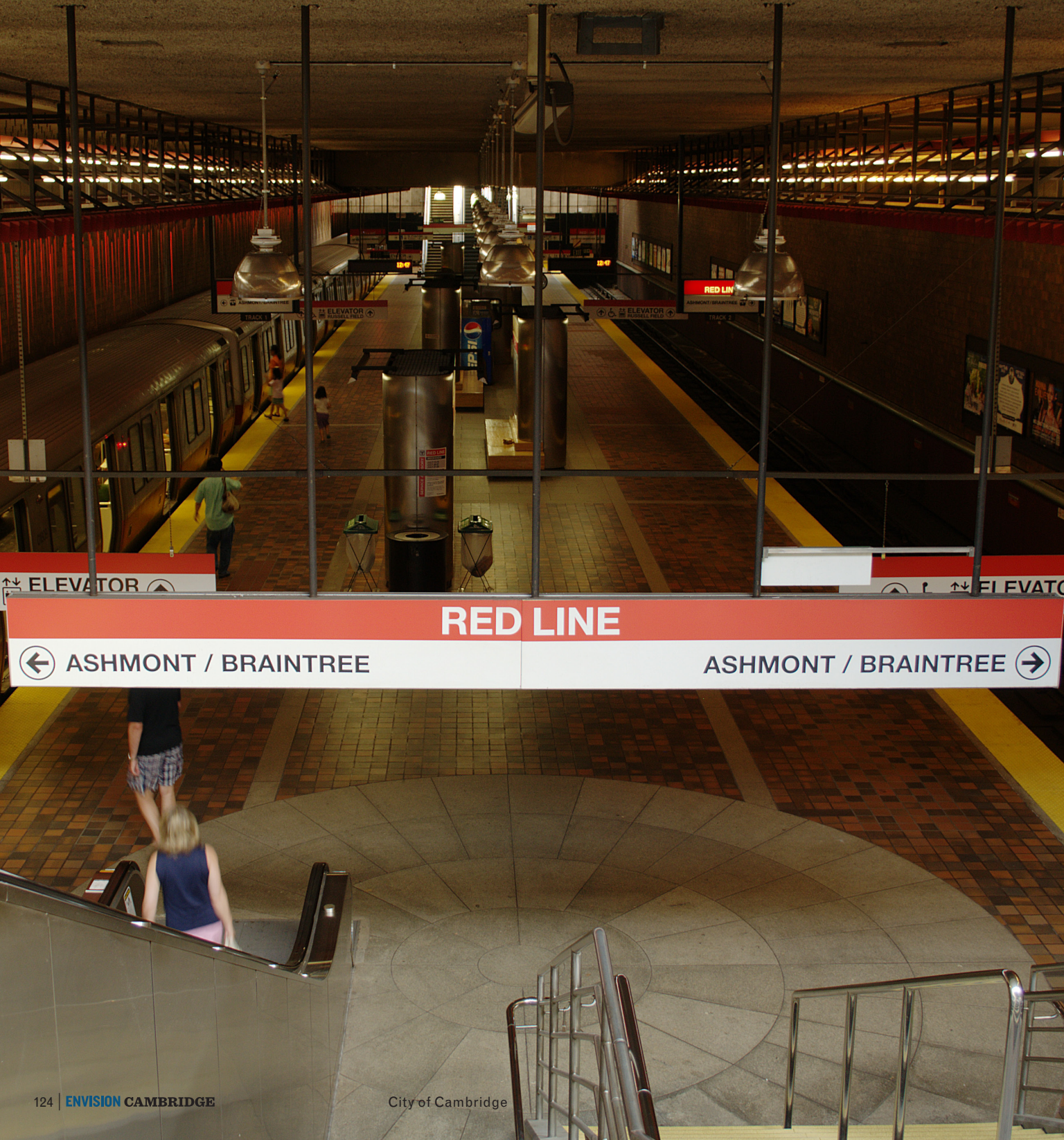

ELEVATOR

**RED LINE**

← **ASHMONT / BRAINTREE**      **ASHMONT / BRAINTREE** →

ELEVATOR

## Mobility

Traffic congestion, lack of connections, and auto-oriented development patterns were identified as key mobility challenges. Infrastructure improvements across multiple modes of transportation and progressive transportation policy are necessary to support greater access and connectivity, and reduce automobile traffic.

The plan proposes three approaches to enhance district connectivity and to facilitate a reduction in automobile traffic. The first strategy involves enhancing all modes of transportation and reducing the dependency on automobile travel. This includes enhanced transportation demand management, improved bus service, shuttles to the Alewife MBTA Red Line station, new bicycle and pedestrian infrastructure, and the replacement of parking minimums with low maximums. Making non-automobile modes more reliable, convenient, and comfortable will lessen the traffic impacts associated with new development in Alewife while also providing secondary benefits like improved air quality, public health impacts, and increased economic activity.

The second strategy is to design the public right-of-way to support the desired character of the district by creating lively and varied street types that improve the experience of the street. A mix of street types is encouraged throughout the district to cater to different needs and accomplish different goals. Differences among the types

include the width of vehicle lanes; the width of the sidewalk; and the presence of bicycle facilities, street trees, and street furniture.

The third strategy includes the provision of new connections. The new roadway connections are intended to provide better access within the subdistrict, create a finer-grained street grid that better distributes traffic, and reduce the length of blocks to make walking more convenient and appealing. New roadway connections will be primarily located within the Quadrangle and will mostly align with the existing parcel boundaries.

A priority is to connect Fawcett and Wheeler Streets to Terminal Road to provide an alternative route between the Shopping Center and the Quadrangle that does not rely on Alewife Brook Parkway and Concord Avenue. In the near term, the connection between Fawcett and Wheeler Streets will be completed through the redevelopment of the 55 Wheeler Street parcel.

A new open space network that provides off-street paths for cyclists and pedestrians will connect the Quadrangle, Shopping Center, and Fresh Pond Parkway subdistricts. A proposed bicycle and pedestrian bridge over the MBTA Commuter Rail tracks will supplement this loop and connect the Triangle and the Quadrangle, enabling cyclists and pedestrians to reach the Fresh Pond trail network, the Minuteman Path, and the Alewife Linear Park without traveling on Alewife Brook Parkway or Concord Avenue.

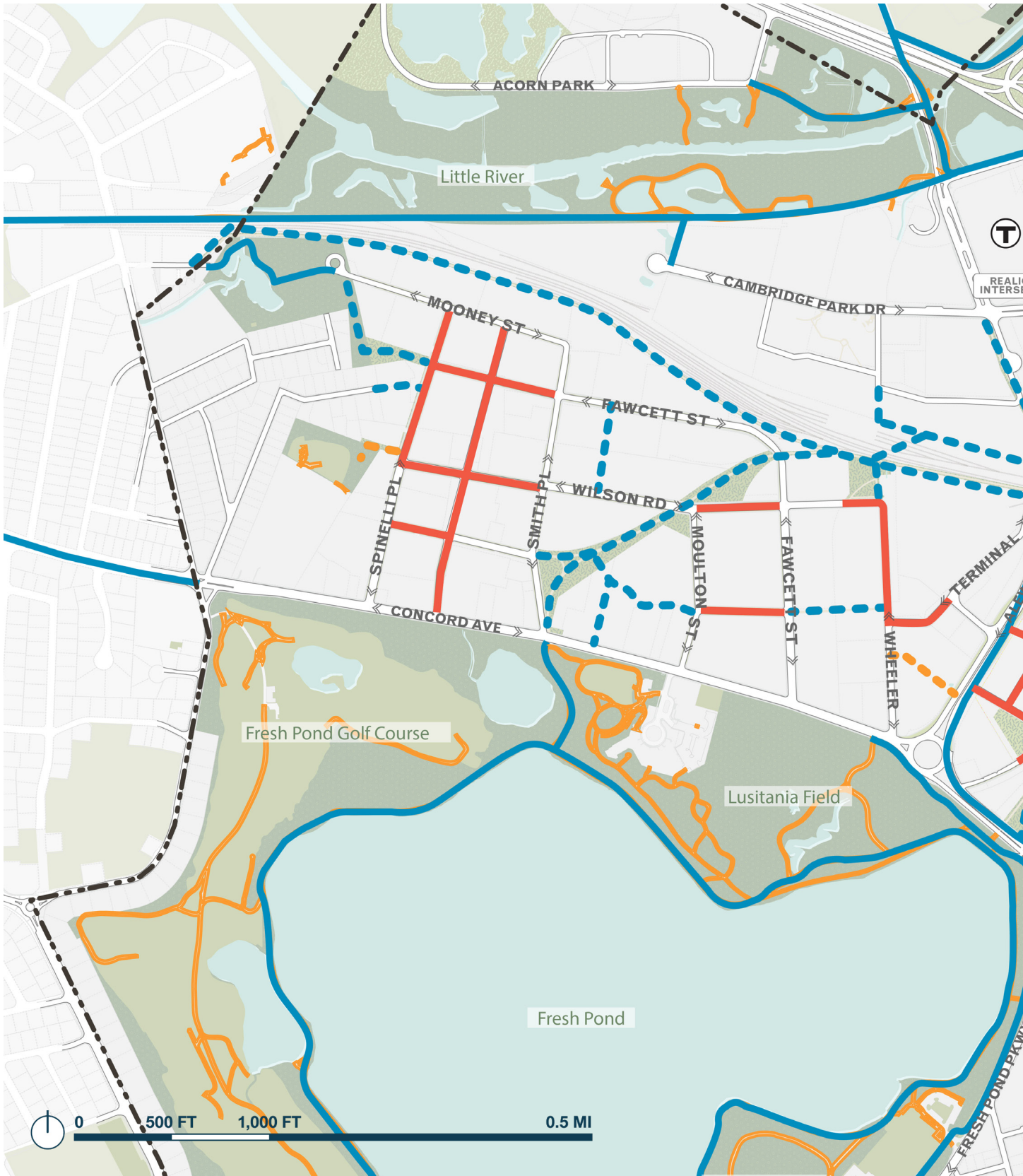

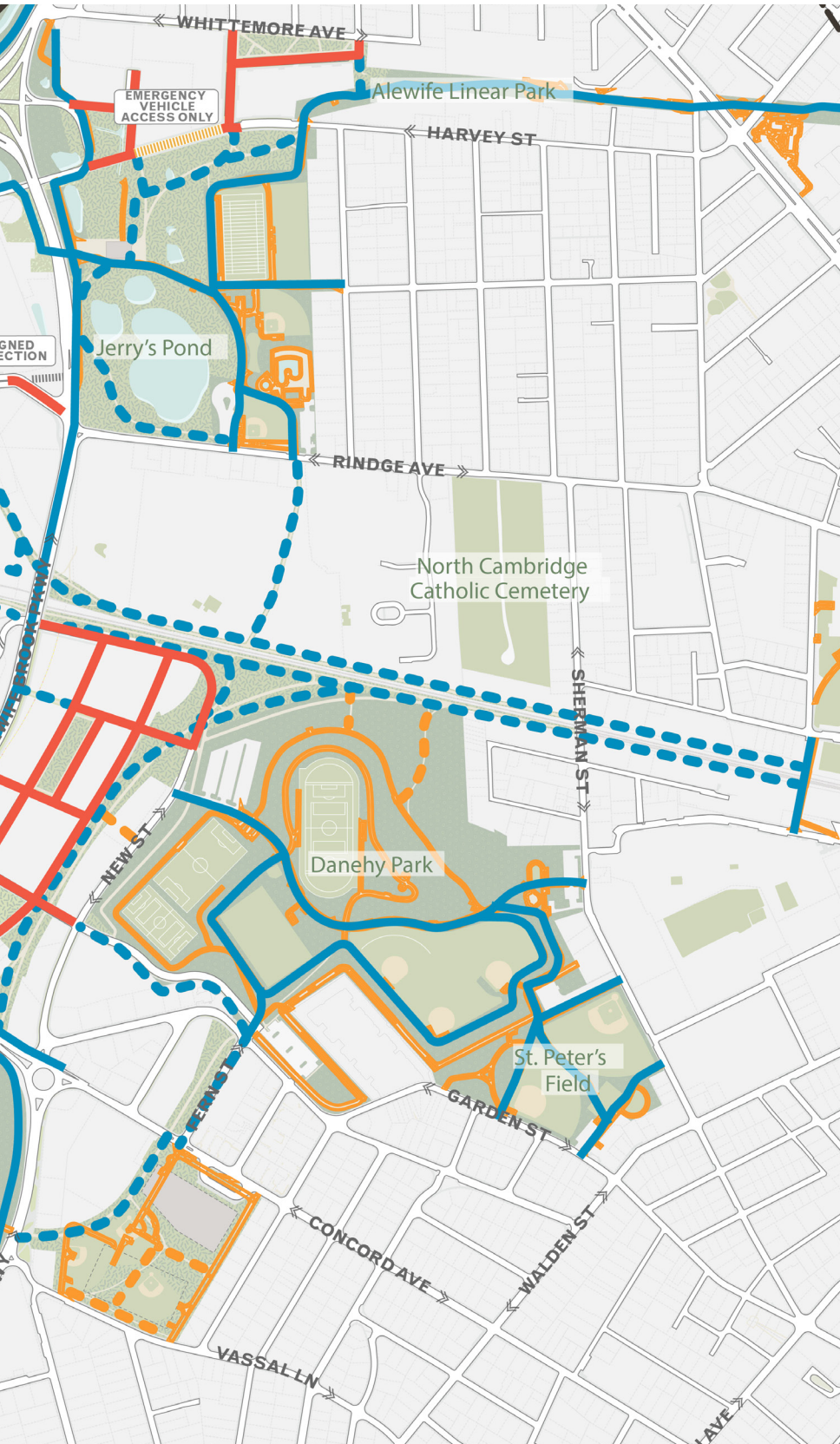

### Conceptual Street Plan

The conceptual street network is intended to show a finer-grained street grid that reduces the length of blocks, creates a more urban and people-oriented environment, and improves circulation for all modes. Blocks should be no more than 400 feet long; however, this may differ in the industrial area. New streets proposed within development parcels serve as diagrammatic representations of potential configurations. The exact layout and design will be determined during the design review process.

- Proposed New Streets
- - - Proposed New Streets for Emergency Vehicle Access Only
- - - Proposed Off-Street Bicycle and Pedestrian Facilities
- Existing Off-Street Bicycle and Pedestrian Facilities
- - - Proposed Off-Street Pedestrian Only Facilities
- Existing Off-Street Pedestrian Only Facilities

## Mobility Recommendations

Notorious for heavy traffic, Alewife has been a transportation planning challenge for decades. Recent growth and the prospect of continued development necessitate that Cambridge and its regional partners address the current condition. These recommendations seek to manage mobility in Alewife through street design, new pedestrian and bicycle connections and facilities, parking management, access to transit, and improved freight logistics.

## Areawide Recommendations

### Street Design

- Construct streets and multi-use paths to provide a finer-grained network that will increase connectivity within and across the district.
- Design streets and building edges to negotiate and link the public way with building interiors.
- Treat streets as travel routes and public places.
- Design primary streets to serve as thoroughfares. Use secondary streets for access to parcels rather than as “through streets”.
- Pursue streetscape enhancements that improve legibility, wayfinding, and identity.
- Locate street trees along the curb edge to buffer pedestrian space from travel lanes.
- Place utility lines underground where feasible and not impacted by future flood projections.
- Enhance the street grid with new local roads and multi-purpose paths for better connectivity, and a more flexible and efficient mobility network.

### Bicycle and Pedestrian Connections

- Implement recommendations from the Citywide Bicycle Plan to improve bicycle infrastructure within and to Alewife.
- Install wayfinding signage that includes walk/bike travel times to key destinations and centralized parking locations.
- In pace with development, build a bicycle and pedestrian bridge that will connect the Quadrangle to the Triangle. *For more information on the bicycle and pedestrian bridge, see “Bicycle/Pedestrian Bridge” on page 133.*
- Evaluate a second bicycle/pedestrian bridge across Alewife Brook between Discovery Park and Cambridgepark Drive in the long term.
- Increase the number of streets and non-vehicular connections, upgrading connectivity within Alewife to match the internal connectivity of other Cambridge neighborhoods.
- Construct bicycle routes that provide an alternative to the parkways.
- Enhance the desirability and usefulness of existing connections between subdistricts.
- Preserve the ability to create future connections between subdistricts by regulating the siting of buildings and public control of land.
- Align multi-use paths and on-street bicycle infrastructure to connect with existing bicycle facilities and crosswalks across major streets and parkways.
- Add Bluebike Stations within a 2.5 minute walk to buildings in pace with development.



Multi-use paths should connect to larger open spaces and integrate seamlessly with the district's street network.



## Parking and Transportation Demand Management (PTDM)

- Implement low maximum parking ratios, rather than minimums, across the entire district in order to discourage driving.
- Encourage shared parking garages in new development, particularly in the Shopping Center subdistrict, to consolidate parking and eliminate surface parking lots.
- Require all new development to have an individual mode share target with the automobile mode share equal to or less than the district-wide automobile mode share target.
- Require new commercial building owners to provide enhanced PTDM, including charging market-rate parking to end users.
- Encourage conversion to electric vehicles through investment in public and private electric vehicle infrastructure as a means of reducing greenhouse gas emissions.
- Require all future commercial development to pay \$5 per square foot into a transportation improvement fund for the district.

## Bus Service

- Work with the MBTA to implement the bus signal priority feasibility study to facilitate left turns from Steel Place for buses entering Alewife Station, and left turns onto Cambridgepark Drive for buses exiting Alewife Station.
- Work with MassDOT to create bus and/or shuttle-only lanes on the Alewife Station Access Road, into Alewife Station from Route 2 and out of Alewife Station under Alewife Brook Parkway back to Route 2.
- Add signal priority along Concord Avenue and advocate for increased bus frequency along Concord Avenue in the near term.
- Support the Commonwealth in building a commuter rail station in the long-term.

## Shuttles to the Alewife MBTA Station

Work with the Alewife Transportation Management Association (TMA) to:

- Study how to improve headways and routing.

- Provide shuttle access to Alewife residents for free or a small membership fee.
- Study the impact of extending the 128 Business Council shuttles to the Quadrangle.
- Study the impact of new suburban park & ride routes.
- Expand corporate offerings such as discounted Bluebikes memberships, priority carpool parking locations, and public bike-share discounts.
- Pilot an Alewife TMA route from Belmont Center commuter rail station to the Quadrangle.

## Freight Connections

- Use signage and wayfinding to encourage freight vehicles to use a limited number of streets.
- Indicate preferred truck routes by using larger curb radii at intersections where truck traffic is appropriate and minimum acceptable curb radii elsewhere to discourage truck traffic.
- Encourage freight loading for new developments on a limited number of streets, and design the remainder of the street network with elements that discourage truck traffic.

## Quadrangle Street Types

Due to the rate of development in the Quadrangle, it is likely that most streets will be upgraded and new streets will be constructed. The plan below outlines the preferred bicycle facilities and associated street types per street. The street types located on the right are illustrative of the preferred dimensions, mix of pedestrian, bicycle, vehicular uses, and landscape buffer spaces.

### Proposed Street Types in the Quadrangle

-  Grade-Separated Bicycle Lane with Additional Elevated Walkway
-  Grade-Separated Bicycle Lane
-  Bicycle Lane
-  Shared Lane Pavement Marking

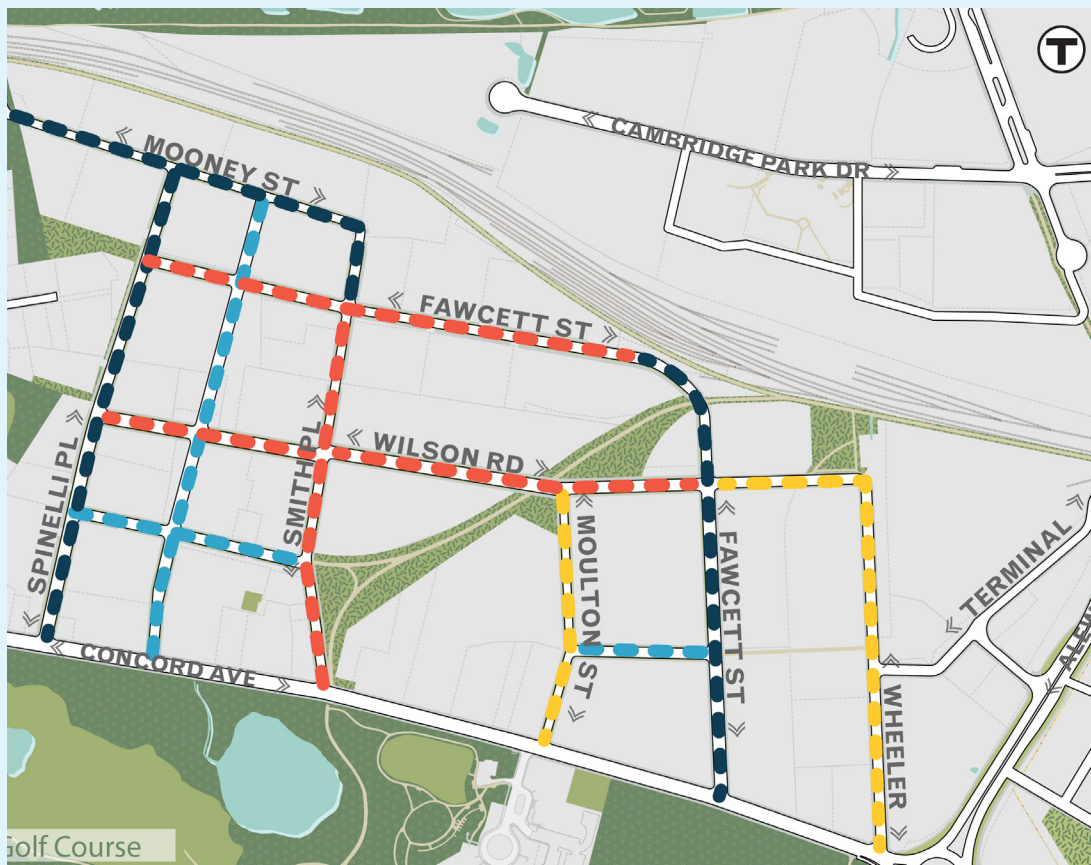

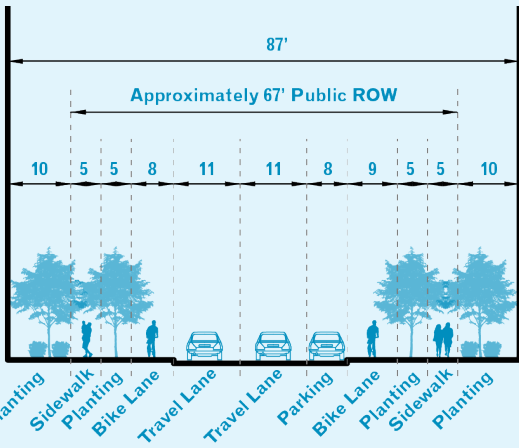

**Grade-Separated Bicycle Lane**

Spinelli Place, Mooney Street, and portions of Fawcett Street should include a grade-separated bicycle lane within the road design.

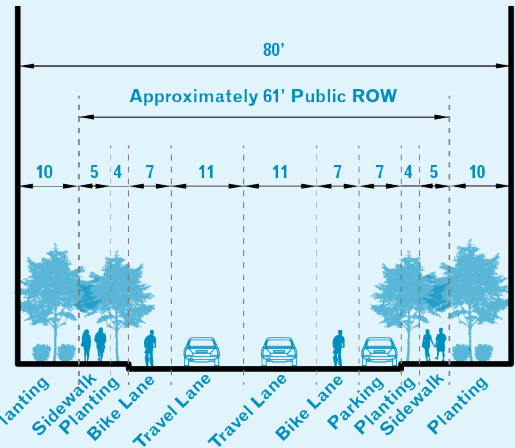

**Bicycle Lane**

This street type recommends the inclusion of an on-street bicycle lane along Moulton Street and Wheeler Street.

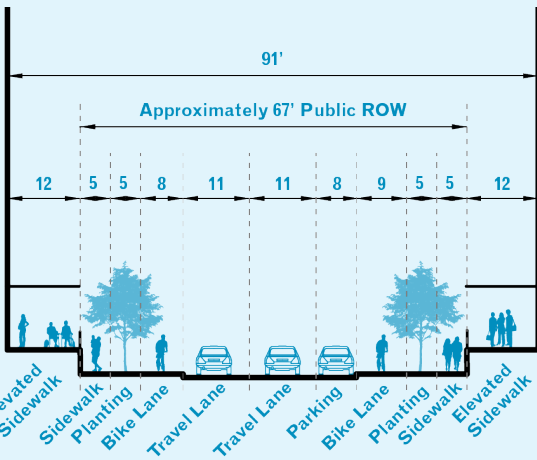

**Elevated Walkway with Grade-Separated Bicycle Lane**

Most of the light industrial and retail spaces within the Quadrangle will be located along Smith Place, Wilson Road, and portions of Fawcett Street. To ensure continuous access to elevated first floors, a publicly-accessible elevated walkway is recommended on private property adjacent to the public rights-of-way on these streets. Included within the public rights of way are a traditional at-grade sidewalk, a grade-separated bicycle lane, vehicular lanes, and street parking.

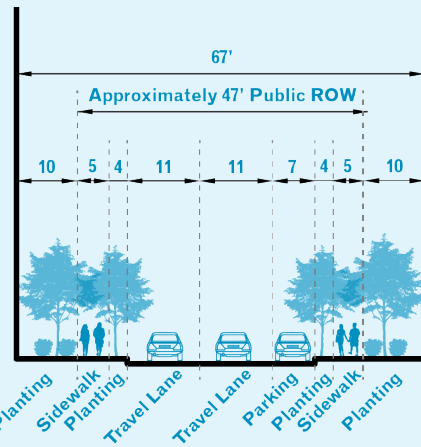

**Shared Lane Pavement Marking**

This street type recommends shared lane pavement markings, such as sharrows, on mid-block streets (see map).

## Subdistrict Recommendations

### Quadrangle

- Introduce new street types to accommodate the variety of vehicular and non-vehicular traffic. *For more information on “Quadrangle Street Types”, see page 130.*
- Improve the bicycle and pedestrian network by adding sidewalks, high visibility crosswalks, and bicycle facilities to all new and proposed streets.
- Create new bicycle and pedestrian connections to increase access to public amenities.
- Provide clear and safe crosswalks at intersections and mid-block crossings with special attention towards streets carrying large trucks.

### Shopping Center

- Create two north-south streets and internal connections to improve accessibility and connectivity within the Fresh Pond Mall superblock.
- Extend the east-west Terminal Road connection to improve accessibility from the Quadrangle to the Shopping Center, as a two-way street connecting to Wheeler Street with an adjacent two-way multi-use path and regularly spaced street trees.
- Create accessible pedestrian connections from Alewife Brook Parkway down to the shopping center storefronts, either through passages in new buildings framing the street or via open stairs, ramps, and terraces.
- Create a publicly-accessible stair and elevator or ramp from the eastern side of Alewife Brook Parkway down to Terminal Road.

### Whittemore Avenue

- Build new streets between Whittemore Avenue and Harvey Street, enhancing connectivity. Align these streets with existing streets north of Whittemore Avenue and connect to the Harvey Street extension.
- Make public the existing private way, “Alewife Center,” which runs from the Alewife Station Access Road through the GCP Applied Technologies office site, up to the intersection of Whittemore Avenue and Alewife Brook Parkway. Truncate this street so that it loops back to the Alewife Station Access Road, where that street enters onto Concord Turnpike.
- Extend the Harvey Street right-of-way to connect to the realigned Alewife Center/ Alewife Station Access Road. Limit vehicular access to the connection between Harvey Street and the realigned Alewife Center, allowing only pedestrians, cyclists, and emergency vehicles to use this connection.

### Fresh Pond Parkway

- Connect Danehy Park to the Fresh Pond Reservation by extending the path along Fern Street through the Tobin School site.
- Align the extended Fern Street path with existing crossings across Fresh Pond Parkway.

### Triangle

- Provide a pedestrian/bicycle bridge connection across the railroad tracks to the Quadrangle.
- Provide additional multi-use paths to the Alewife Brook Reservation.
- Create a multi-use path connection under the Alewife Brook Parkway Bridge to the Rindge Apartments area.

## Bicycle/Pedestrian Bridge

The construction of a bicycle and pedestrian bridge connecting the Quadrangle and Triangle subdistricts is an important element to improve access to public transit and within the district.

### Benefits

There are several benefits to the construction of a new bicycle and pedestrian bridge. These include:

- A new connection between the Triangle and Quadrangle subdistricts for pedestrians and cyclists.
- Improved access to the Alewife MBTA Station.

- Shift towards non-automobile modes of travel and, thus a reduction in the number of vehicles traveling daily along Alewife Brook Parkway.

### Timing

Funding for an Alewife bicycle and pedestrian bridge is not reflected in the City's five-year capital plan so its construction is contingent on the adoption of the Alewife District Plan and related zoning and development. If development occurs in a timeline consistent with build-out projections, design for a bridge could start three years after the new

zoning is in place, with construction starting in six to seven years and completed at approximately 40% build-out. The city will track development and integrate plans for a bridge into future budgets at the appropriate time.

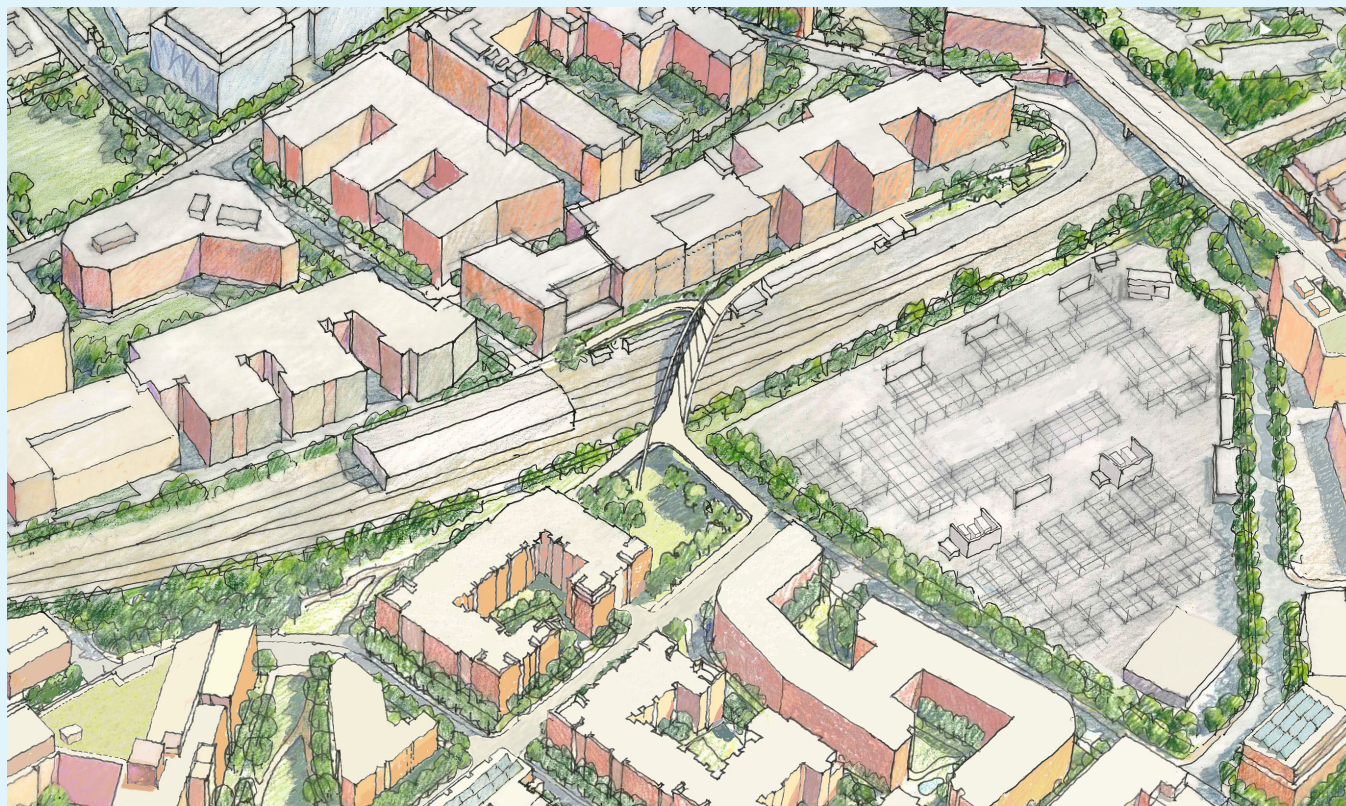

An artistic rendering illustrates a conceptual bicycle and pedestrian bridge connecting the Quadrangle and Triangle subdistricts.



---

## Climate and Environment

In order to achieve a sustainable, resilient future, the plan incorporates climate change mitigation and resilience strategies that address the specific challenges facing Alewife. Recommendations include strategies for mitigating temperature increases and flooding associated with precipitation and storm surge inundation via the Alewife Brook. The Climate Change Preparedness and Resilience (CCPR) Plan for Alewife serves as the foundation for several of the recommendations in this plan. The urban landscape of Alewife, like the rest of Cambridge, must transform to adapt to future conditions, including existing and new buildings, infrastructure, and public spaces. This plan aims to adopt the sustainability measures proposed citywide by the CCPR plan, while ensuring walkability, connectivity, and a sense of place in Alewife.

In addition to climate change preparedness, Alewife will take measures toward implementing policies that advance sustainable development, such as incentivizing the reduction of energy use and GHG emissions, improving transit access, and encouraging on-site energy generation.

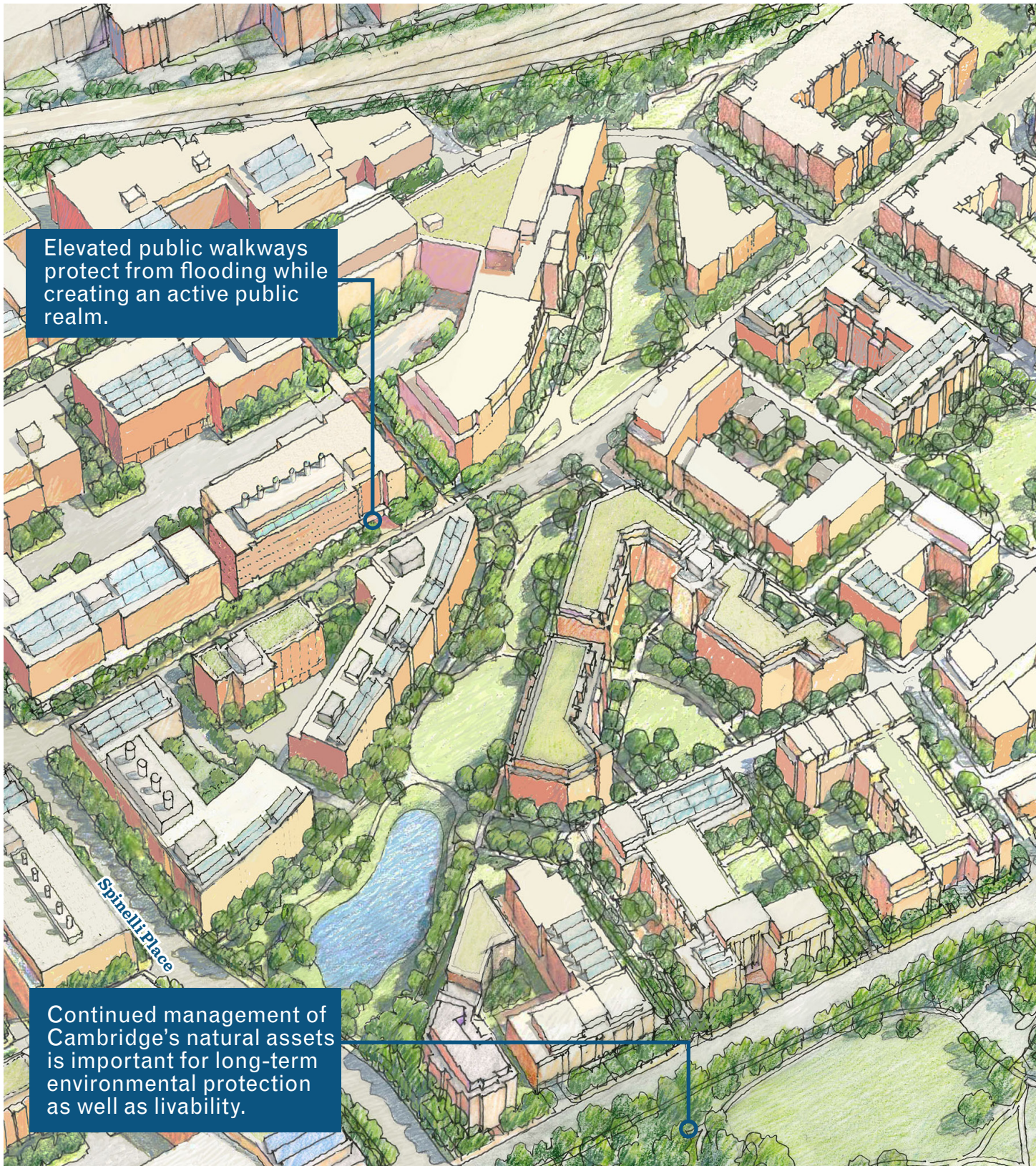

Elevated public walkways protect from flooding while creating an active public realm.

Continued management of Cambridge's natural assets is important for long-term environmental protection as well as livability.

Spinelli Place



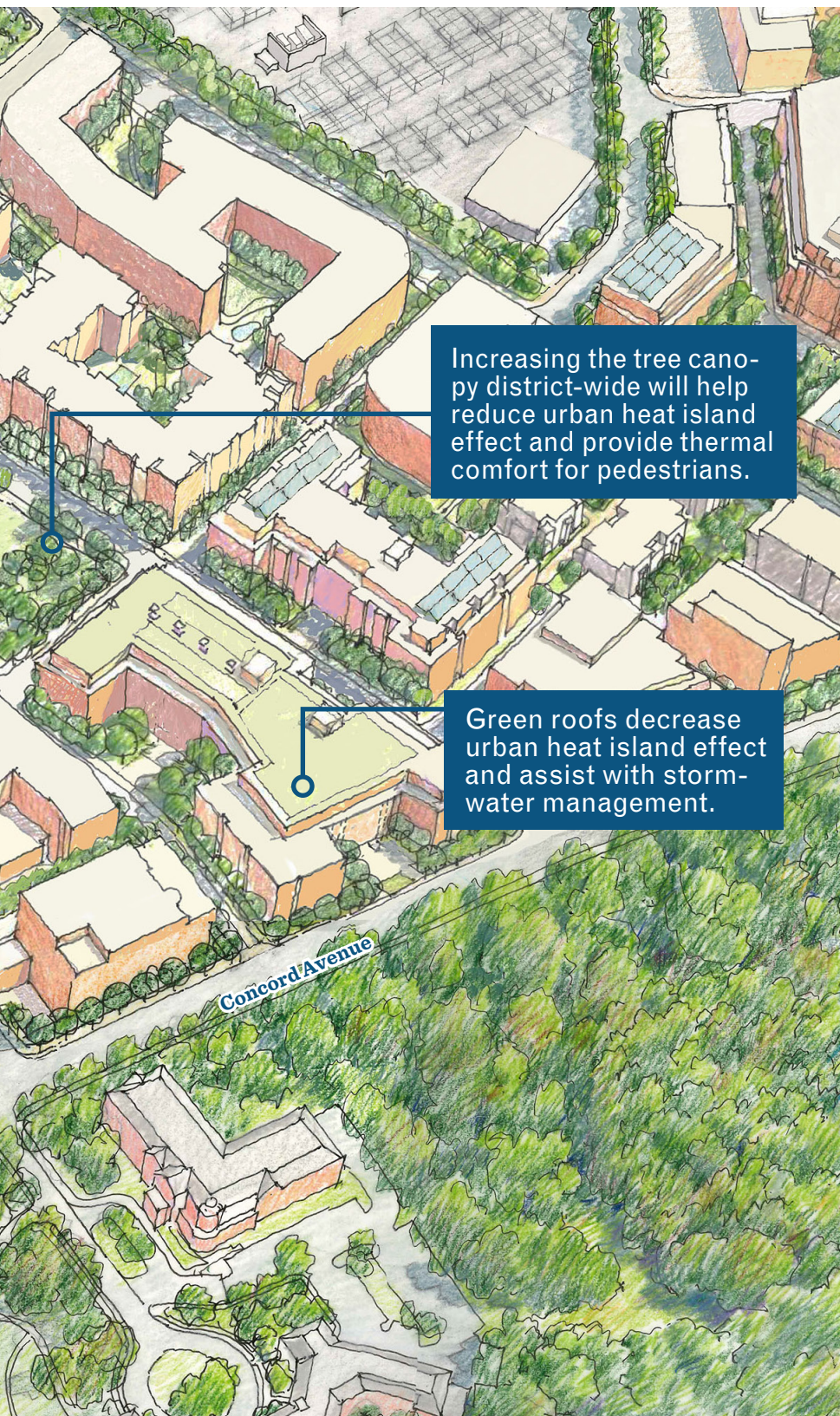

Increasing the tree canopy district-wide will help reduce urban heat island effect and provide thermal comfort for pedestrians.

Green roofs decrease urban heat island effect and assist with storm-water management.

Concord Avenue

A conceptual aerial view of development in the Quadrangle subdistrict illustrates many of the resilience recommendations for Alewife, including an increase in permeable surfaces, green roofs, and an elevated public walkway in the Quadrangle subdistrict.

## Climate and Environment Recommendations

This plan lays out strategies to create a sustainable and resilient Alewife. Recommendations include strategies for flood and heat mitigation and adaptation, reduced building energy consumption, improved air quality, and enhanced tree canopy and green spaces.

### Areawide Recommendations

#### A Prepared Community

- Establish a neighborhood resilience hub to foster community networks and increase preparedness and resilience among residents and businesses through education, training, planning, and implementation of resilience and sustainability measures.
- Establish a program to identify and support individuals who are more vulnerable due to health conditions, homelessness or social

isolation, and develop community support and emergency response systems to ensure their safety and well-being.

- Develop localized communication systems to provide back-up during outages of telephone, cellular, cable and internet services.
- Incorporate new and existing neighborhood amenities—like the Neville Senior Center and West Cambridge Youth Center—as potential assets for resiliency hubs or cooling centers.
- Increase resilience of critical community facilities to climate impacts, prioritizing those with high vulnerabilities identified in the Climate Change Vulnerability Assessment and detailed in CCPR.
- Strengthen existing emergency response plans to include the potential impacts of climate change, including strategies to enable sheltering in place and evacuation when appropriate.

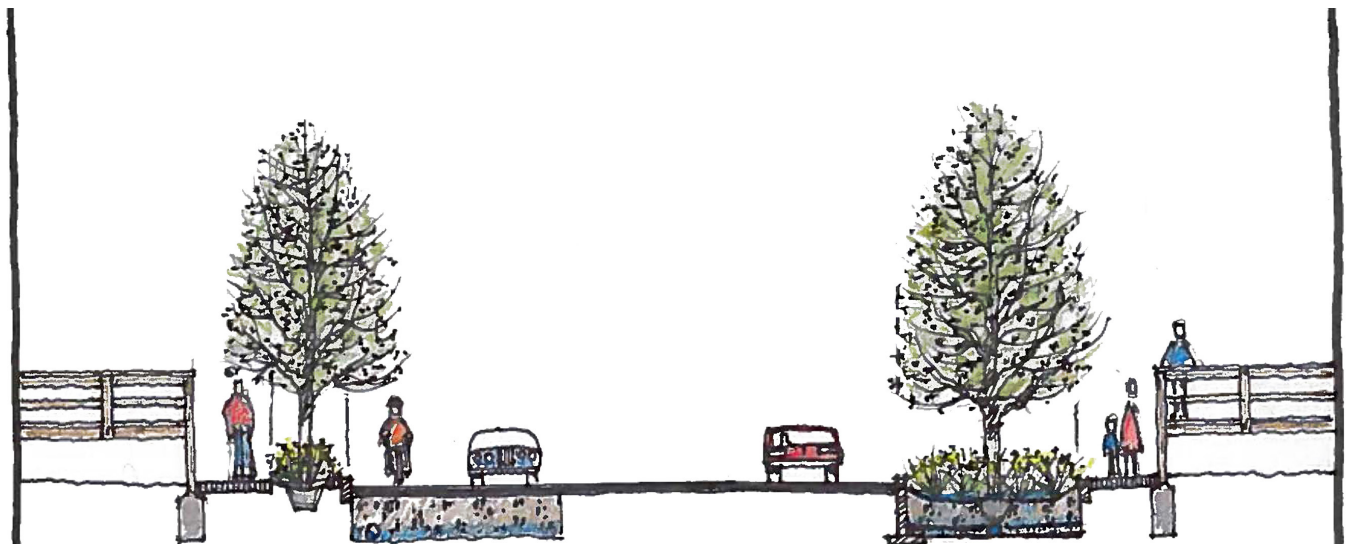

A street section from the CCPR Plan demonstrates the integration of stormwater management and resiliency features into the streetscape (see Mobility section on page 130-131 for detailed street sections).

## Adapted Buildings

- Build/protect to the 2070 10-yr (10% annual chance) flood elevation from sea-level rise plus storm surge (SLR/SS) and recover to the 2070 100-yr (1% annual chance) flood elevation from SLR/SS.
- Require building utilities to be located above the 2070 100-yr flood.
- Develop requirements for floodproofing of structured parking.
- Develop flood protection standards for building systems.
- Incorporate mitigation and resilience strategies into all new construction and retrofits of existing buildings and align with Cambridge's net zero building goals.
- Establish regulations and design guidelines for new buildings to be resilient to future heat risks.
- Require all roofs, parking decks, and other surfaces to be high albedo with minimum Solar Reflectance Index (SRI) requirements.
- Establish a program to support retrofitting of buildings to be resilient to flood risks.



Elevated walkways are increasingly common today in potential flood zones, like Boston's Fort Point Neighborhood above.

## Resilient Infrastructure

- Protect Fresh Pond Reservoir from future flooding impacts including salt water intrusion.
- Engage the MBTA and MassDOT to increase the resiliency of major transportation and transit infrastructure like the Alewife MBTA Station to ensure mobility and access to evacuation routes.
- Complete the street grid by adding new local roads to improve connectivity to the Alewife train station and provide options for detour routes (e.g. in case of flooding).
- Plan, design, and implement storm surge barriers and improvements at appropriate sites
- Evaluate the collective benefits of adopting updated stormwater storage requirements at the parcel scale to prevent flooding at the sub-neighborhood scale.

### Net Zero Action Plan

Buildings should adhere to the City's net zero standards to reduce greenhouse gas emissions, as outlined in the Net Zero Action Plan. The plan identifies strategies to put Cambridge on a trajectory towards becoming a carbon neutral community. It includes recommendations to improve the energy efficiency of existing buildings and require net zero new construction through a combination of energy efficiency improvements and renewable energy production from on-site and off-site energy sources.



Development guidelines and resilience zoning requiring green infrastructure like that of this development in Freiburg, Germany can improve environmental quality as well as the public realm.

- Continue sewer separation to reduce adverse public health impacts.
- Prepare existing infrastructure, neighborhoods, and community resources for climate change, in particular, the challenges of flooding and heat.
- Engage with state and regional partners to increase resilience of critical infrastructure (Alewife electrical substation; MBTA transit infrastructure; Amelia Earhart Dam).

### Resilient Ecosystems

- Reduce the urban heat island effect by increasing the urban forest canopy, developing a comprehensive urban forest management plan, and continuing urban forest maintenance efforts as proposed in CCPR and the Urban Forest Master Plan.
- Encourage minimal surface parking, green and/or white roofs, and high albedo surfaces to decrease the urban heat island effect.
- Reduce impervious area of upstream parcels

to limit flooding downstream. Evaluate the implementation of a combination of vegetated and non-vegetated infrastructure in parcels upstream of flood-prone areas to reduce runoff from impervious areas.

- Increase pervious surfaces throughout the district, both on private lots and through street design that incorporates landscape features such as bioswales.
- Require 25% of each lot’s total area to be pervious surface.
- Require a minimum of 20% of each lot to be open space.
- Increase stormwater storage options within private developments and on City-owned parcels and rights-of-way.
- Locate parking under habitable building space or cover it with a landscaped deck in order to minimize the influence of the urban heat island effect and stormwater runoff.
- Require green or white roofs on areas not occupied by mechanical equipment or solar panels.

## Proposed Tree Planting Strategy

The following planting strategies should be incorporated on streets and parkways as well as setbacks, open spaces, and other areas of the public realm. Recommendations for particular species will be included in the City of Cambridge's Urban Forest Master Plan.

### Streets and Parkways

- Require tree planting on all streets and parkways to provide shade and improve the quality of the public realm.
- When new streets are constructed and existing streets rebuilt, locate underground utilities within the street, not the sidewalk, to provide maximum soil depth for street trees.

### Setbacks, Open Spaces, and the Public Realm

- Maximize planting to provide full canopy coverage.
- Maximize species diversity and prioritize habitat-supporting tree species.
- Select tree and plant species that will be able to adapt to a changing climate.



Main Street in Kendall Square showing the extent of sand based structural soil.



Main Street in Kendall Square demonstrates the system of soil and drainage necessary for healthy street trees to grow and thrive.

### Environmental Sustainability

- Implement green infrastructure projects to improve water quality and reduce flooding impacts from smaller rainfall events.
  - Protect Fresh Pond Reservoir from future flooding impacts.
  - Continue combined sewer separation in the Alewife area to reduce adverse public health impacts during flood events and protect water quality.
  - Line all streets with trees, planted at typical intervals for retail streets, and planted as tightly as possible for non-retail streets. This should range between 20-ft and 30-ft between trunks, based on the canopy size.
  - Follow recommendations for tree species included in the Urban Forest Master Plan.
  - Maximize planting of trees and bioswales in all public and private off-street open areas.
- Formulate policies that incentivize the reduction of energy use and GHG, and preserve landscape and habitat.
  - Encourage on-site energy generation.
  - Reduce automobile dependence through improvements in transit and infrastructure that promote resident and employee health through walking and biking.
  - Reduce traffic congestion and traffic volume to decrease auto emissions. *For more information on ways to improve air quality by reducing vehicle trips, see “Mobility Recommendations” on page 124.*
  - Encourage the use of electric vehicles and the provision of charging stations across the district in line with citywide recommendations for electric vehicle use.



Green infrastructure, like these plantings along the Bloomingdale Trail in Chicago, can improve water quality and reduce flooding impacts.

## Subdistrict Recommendations

### Quadrangle

- Build/protect to the 2070 10-yr flood elevation, but no greater than 4 feet above the adjacent sidewalk, for the first occupiable floor.
- Upon redevelopment, encourage private property owners to construct elevated walkways on select streets, which include at least one means of ADA compliant access plus one additional access point per 200 feet of street frontage.
- Introduce different street types to reduce the impact of an elevated first floor on the public realm.

### Whittemore Avenue

- Incentivize development to invest in open space improvements in and around Jerry's Pond.

### District Energy

Redevelopment in Alewife is a unique opportunity to consider new solutions for energy production and distribution such as district energy. A district energy system supplies energy to individual buildings from one or more centralized energy sources. Due to network efficiency, individual buildings experience lower energy costs and reduced emissions. In addition, a centralized system makes it easier to shift to lower-carbon fuel sources over time compared to each individual building changing fuel sources.

Based on an analysis of projected energy demand, Alewife is an ideal location for district energy. As the district redevelops, it will be important to design buildings to allow for connection to a potential privately owned and operated district energy system. District energy systems can increase energy resilience by providing shared energy storage and the opportunity for microgrids, which can maintain power during outages.



An elevated walkway will provide a secondary public realm as a result of raising the first floors of buildings to protect from future flooding.





---

## Housing

The community identified a desire to transform Alewife into a mixed-use district. Residential development plays an important role in the social cohesion of a neighborhood and ensuring activity over the course of the day. The proposed land use plan and projected redevelopment indicates there could be more than 2,000 net new housing units in Alewife at 60% buildout, including more than 400 net new affordable units. The plan identified the Quadrangle and the Shopping Center as significant growth centers for many of these new housing units. If new growth is consistent with the size and household structure in recent Cambridge developments, this could bring more than 4,000 net new residents to the area, including an estimated 230 public school students, or roughly one new student for every 17 new households.

The following recommendations are closely aligned with the recommendations of the Envision Cambridge citywide plan, which addresses housing policy in more detail. The recommendations for Alewife fit into the larger citywide effort to accommodate an increase in residential units, including a significant amount of new affordable housing.



New housing development in Alewife should be planned for and encouraged as part of the larger citywide goal to increase housing stock.

## Housing Recommendations

The recent commercial development in Alewife, balanced with ongoing housing construction, facilitates the potential of a “walk-to-work” district, while still providing close access to the Alewife MBTA station for commuters. Monitoring this growth against its impacts on adjacent neighborhoods and the creation and preservation of affordable housing stock are considered as part of the plan’s recommendations.

## Areawide Recommendations

### Connected and Integrated Alewife

- Increase the amount of housing in Alewife, particularly in the Quadrangle and Shopping Center.
- Incorporate a diverse range of housing options for different households and lifestyles, including townhouses and multifamily residential buildings.

- Increase housing affordability by introducing a range of price points.
- Minimize the impact of new development on adjacent residential neighborhoods.
- Buffer historic residential neighborhoods such as the Cambridge Highlands from commercial and industrial uses with mid-density residential uses.
- Encourage transformation of commercial parcels to mixed-use with residential uses on upper floors to better complement the surrounding neighborhood.
- Encourage low- to mid-density residential development in the southwest corner of the Quadrangle.
- Provide a variety of housing types, including townhouse and live-work spaces.
- Encourage energy efficiency and renewable energy use in new development to reduce household energy costs.

### Net New Housing Units at 60% Buildout

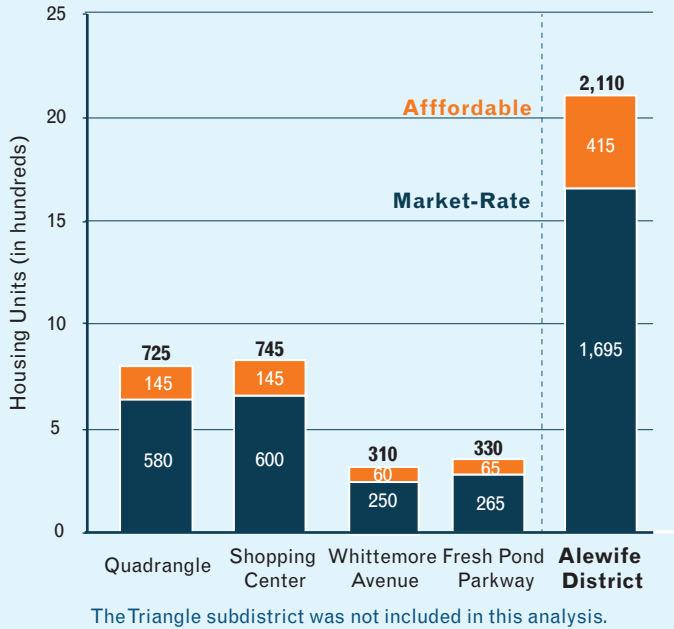

**The proposed land use plan could generate more than 2,000 net new housing units in Alewife.**

### Net New Residents and Public School Students at 60% Buildout

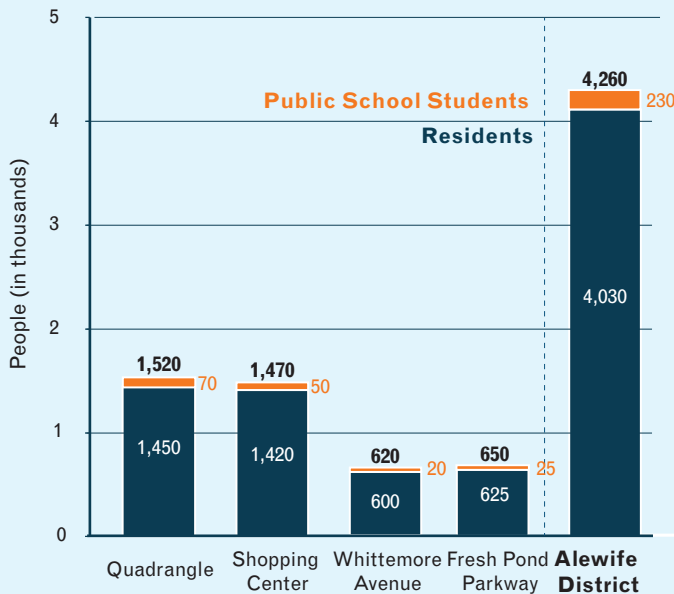

**This would in turn introduce more than 4,000 new residents to the area.**

Estimates are based on data from Cambridge Public Schools and the Census Bureau, while taking into account the effect of the City's Inclusionary Housing Program. The Triangle subdistrict was not included in this analysis.



---

## Economy

Alewife should continue to serve as an employment hub and economic driver in Cambridge. The proposed land use plan balances housing growth with economic growth so that new development will support diverse job growth, generating a positive impact on the Cambridge economy. This plan projects that 9,000 new jobs will be located in Alewife if 60% of the district is redeveloped. Roughly 80% of these jobs (about 7,200) will be in office and laboratory settings, and nearly 800 jobs will be within light industrial businesses.

A critical aspect of realizing Alewife's vision is continued job growth that creates economic opportunity for a diverse range of businesses and residents and contributes to a local sense of place. The community stressed the importance of preserving and expanding the types of businesses that currently exist in Alewife. Legacy businesses, such as Iggy's Bread of the World, Gymnastics Academy of Boston, Central Rock Gym, Longleaf Lumber, and Anderson McQuaid, serve vital community functions, including unique products and retail experiences, important amenities for Cambridge residents, community gathering spaces, and low barrier-to-entry jobs, or jobs with low education requirements. This plan includes recommendations to retain Alewife as a diverse jobs center while transforming it into a walkable, urban center.

The types of businesses envisioned for Alewife include light industrial businesses as well as community-focused businesses that require light industrial space. Light industry is the production of small consumer goods. Examples include manufacturers of bikes, medical equipment, and furniture (i.e., Artisans Trading Company), and catering food companies (i.e., Iggy's Bread of the World). Community-focused businesses that require light industrial space include businesses like the Gymnastics Academy of Boston and Central Rock Gym. They benefit from larger floorplates and higher ceiling heights and provide places for positive social connection.

## Economy Recommendations

Light industry is at risk of being replaced by more profitable residential and commercial development. A combination of land use tools, business recruitment, and workforce development programs aim to preserve and attract new light industry into Alewife. This plan recommends creating a zoning district that requires the inclusion of industrial space in any commercial development.

The northwest quadrant of the Quadrangle was identified as a location to preserve light industrial businesses by requiring ground-floor space of commercial development to be occupied with light industrial businesses. This hybrid building approach aims to cross-subsidize the light industrial space with high rent generating commercial uses (e.g. office/R&D) on the upper floors.

### Areawide Recommendations

- Foster job growth through commercial (office and laboratory) and industrial development.
- Facilitate site assemblage to support targeted commercial development.
- Support sufficient density, and a mix of uses, to support retail typical of a thriving urban neighborhood.
- Encourage neighborhood supporting retail on Concord Avenue, Smith Place, Cambridgepark Drive, and Fresh Pond Parkway, while retaining the bulk of retail at the Shopping Center.

### Subdistrict Recommendations

#### Quadrangle

- Conduct a study on the creation of a light industrial land trust and implement study recommendations.

- Create a zoning district that requires ground-floor industrial space in commercial developments. *Read more about recommendations for this building type in “Building Types” on page 120.*
- Target light industrial businesses with a strong retail component on Wilson Road
- Incentivize light industrial businesses to locate and stay in Alewife through low-cost capital and targeted business recruitment in line with citywide recommendations.
- Promote growth in industries that present opportunities for local firms to supply a greater portion of regional demand, such as food and beverage manufacturing, medical and metal product manufacturing, and clean energy and climate-smart innovation.
- Conduct a study on the impact of offering tax incentives to attract firms that offer low barrier-to-entry jobs with relatively high wages.
- Highlight and publicize the success stories of industrial businesses located in Alewife.
- Partner with workforce development groups and employers to provide training opportunities for workers that are aligned with the needs of light industrial firms.
- Engage the Alewife community through an annual Alewife Day to promote light industrial careers, expose job seekers to career pathways and businesses in the area, and promote Alewife as a business location.



Iggy's Bread of the World is a wholesale bakery that also includes a retail storefront.

### Net New Jobs at 60% Build-Out

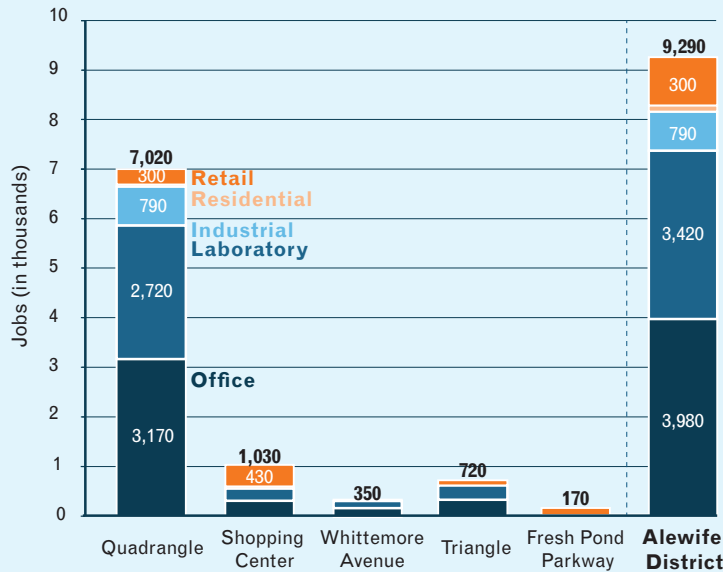

Estimated jobs are based on the number of workers per gross floor area (GFA) of use category. Residential jobs are building leasing, operations, and maintenance jobs.

**The Alewife Planning Study analyzed potential buildout under proposed zoning, which could create up to 9,000 new jobs, including up to 800 jobs in industrial businesses.**

### Annual Fiscal Revenues and Costs at 60% Build-Out

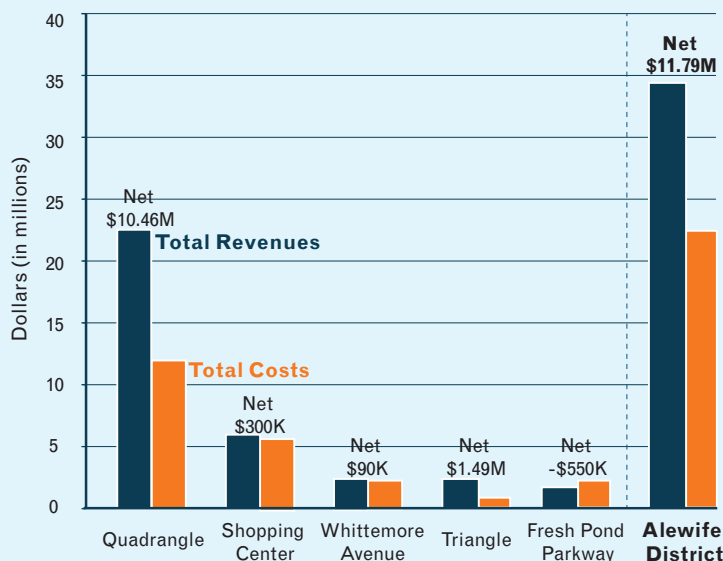

Estimates based on City property taxes, other taxes and fees, general service costs, and education costs for public school students. Costs do not include the unknown remediation costs associated with Jerry's Pond.

**The study analyzed the fiscal impacts of potential buildout under proposed zoning and found that redevelopment could net \$11.8 million in fiscal revenues for the City.**

## Why Light Industry?

### Economic Opportunity

Light industrial jobs provide low barrier-to-entry jobs that pay living wages for underserved communities. They pay an average weekly wage of \$2,342 compared to \$619 for retail and \$580 for food service jobs (EMSI, 2016). Better paying jobs may allow residents to work and remain living in Cambridge.

### Economic Diversity

Light industrial jobs diversify the overall Cambridge economy. In contrast to the established life sciences and technology companies that dominant Kendall Square, light industrial space supports more diverse innovation jobs. Preservation and expansion of light industry support business diversity by allowing local businesses of different types, sizes, and growth stages to start, grow, and remain in Cambridge. It also avoids the risk of over concentration in a limited set of industries.

### Environmental Sustainability

Light industrial development also supports the environmental sustainability of the supply chain. Local production and consumption of goods minimize miles traveled and creates a self-reliant community.

## Light Industrial Jobs and Wages

	National Salary	Regional Salary
<b>Manufacturing</b>	\$80,018	\$114,472
Food	\$56,300	\$62,105
Beverage	\$69,600	\$88,960
Medical Equipment	\$97,400	\$119,630
Fabricated Metal Product	\$65,800	\$86,865
<b>Wholesale Trade</b>	\$85,133	\$112,639
<b>Accommodation and Food Services</b>	\$22,868	\$28,128
<b>Retail Trade</b>	\$35,729	\$39,473

## Defining Light Industry

Light industry is the production of small consumer goods. In contrast with heavy industry, light industry requires fewer raw materials and heavy equipment, needs less square footage, and results in less environmental impact. Importantly, businesses are characterized by a lack of significant nuisances, including noise, fumes, and other hazardous byproducts. They are compatible with a mix of uses and can provide unique retail experiences in a mixed-use urban district. Light industrial businesses also pay relatively high wages with minimum educational requirements.



## Manufacturing in Alewife

An analysis of light industrial job growth identified four industrial sectors that could thrive in the Alewife district: beverage manufacturing; food manufacturing; fabricated metal product manufacturing; and medical equipment and supplies manufacturing.

Beverage, food, and fabricated metal product manufacturing, are in the top ten highest growing manufacturing sectors nationally. While not a high-growing sector nationally, medical equipment and supplies manufacturing is closely related to existing Cambridge economic sectors.



### Food Manufacturing

- Local businesses meet only 38% of regional demand.
- 91% of employees in this sector regionally do not hold a college degree

Includes

- Baked goods
- Fruit and vegetable preserving
- Grain milling
- Confectionery product manufacturing
- Dairy product manufacturing

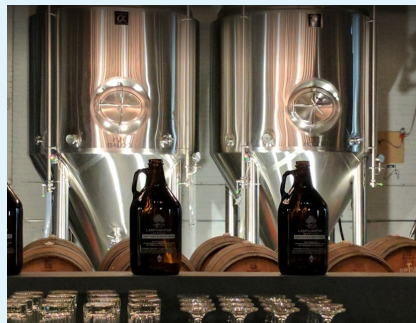

### Beverage Manufacturing

- Local businesses meet only 41% of regional demand.
- 86% of employees in this sector regionally do not hold a college degree

Includes

- Breweries
- Wine manufacturing
- Ice manufacturing
- Soda or tea manufacturing

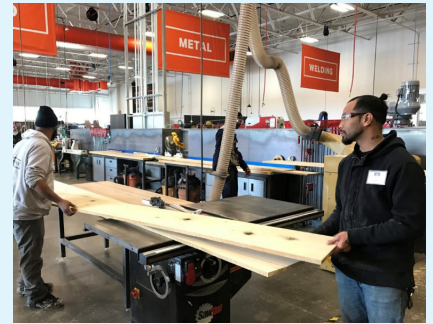

### Fabricated Metal Product Manufacturing

- Local businesses meet only 53% of regional demand.
- 84% of employees in this sector regionally do not hold a college degree

Includes

- Machine shops
- Maker space
- Forging and stamping
- Architectural and structural metals manufacturing



### Medical Equipment and Supplies Manufacturing

- Local businesses meet only 37% of regional demand.

Includes

- Medical Kit Assembly
- Manufacturing of surgical and medical instruments, appliances, and supplies
- Dental equipment and supplies manufacturing



---

## Zoning

Zoning is a key tool to implement many of the recommendations included in this plan. This section outlines key zoning regulations to regulate land use character and set development standards for built form, setbacks and massing, open space, and parking, among others.

## Zoning Recommendations

The Alewife Planning Study recommends continuing a two-tiered zoning approach in this area, in which as-of-right zoning is consistent with existing patterns of development, and a special permit process allows redevelopment consistent with this plan’s recommendations. In general, as-of-right zoning treats existing allowed uses and densities as conforming. The special permit process allows increased density and height in exchange for meeting requirements set forth in this plan, including new streets and other key infrastructure, open space improvements, enhanced urban design, and transportation mitigation.

## Areawide Recommendations

The following zoning recommendations would apply areawide for development proposals seeking density and height above base zoning.

### Built form

In order to encourage a more desirable, urban pattern of development, the plan recommends the following built form standards:

- Maintain prevailing density limits in current zoning with bonuses for providing new roads, a pedestrian/bicycle bridge connecting the Quadrangle to the Triangle, and a linear open space, as identified in the plan.
- Adjust heights to accomplish the following: Promote desired residential and commercial building typologies.
  - Allow greater use of density bonuses for public space and infrastructure
  - Allow more flexibility to employ Transfer of Development Rights (TDR) and density bonuses
  - Promote more private and public open space.
  - Account for higher ground floor elevations for flood protection.
  - Retain lower heights near existing residential neighborhoods.

## Setback Requirements

### Maximum Facade Length

Facade lengths restricted to 200 feet; for buildings where street frontages are more than 200 feet, a courtyard should be incorporated.

- Active Uses
- Commercial
- Residential

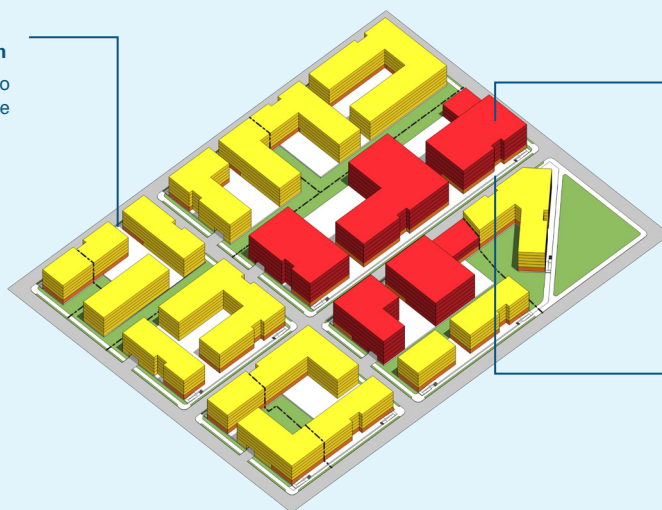

### Side Setback

0 feet within the first 65 feet of the front lot line (required). 15 feet beyond 65 feet to the rear lot line (minimum).

### Front Setback

Establish “build-to” lines for building frontages according to the street types defined on pages 130-131.

- Establish “build-to” lines for building frontages according to the street types defined in this plan. [Read more about “Quadrangle Street Types” on pages 130-131.](#)
- No required sideyard setback within the first 65 feet of the front lot line (recommendation does not apply to industrial buildings).
- Rear setbacks should be used to increase site permeability and reserve space for future green infrastructure.
- Increase open space requirement to at least 20% of the site
- Restrict facade lengths to 200 feet; for buildings where street frontages are more than 200 feet, a courtyard should be incorporated (does not apply to industrial buildings).
- Elevate first floors to the projected 2070 10-yr SLR/SS elevation. Accomplish this by: raising streets; providing elevated walkways; or using raised green yards with low retaining walls. Berms are discouraged.
- Encourage ground-floor retail or other active uses at key locations identified in this plan.
- Locate parking below first occupiable floor or covered by a landscaped deck and hidden from view from streets and open spaces.

### Mobility

The following transportation standards aim to decrease automobile reliance and promote walking, bicycling, transit:

- Eliminate minimum parking requirements, except for residential development.
- Set low maximum parking ratios by use to prevent overbuilding of parking, reduce vehicle trip generation, and encourage multi-modal transportation.
- Require enhanced transportation demand management measures. [Read more about TDM recommendations on pages 127.](#)
- Allow pooled/shared parking and encourage in special permit criteria.
- Require all future commercial development to pay \$5 per square foot into a transportation improvement fund for the district.
- Locate driveway access and off-street parking on streets without elevated walkways or active ground floor use, where feasible.

## Parking Requirements

Establish maximum parking requirements, as a way to limit the amount of permitted parking and reduce unnecessary parking inventory instituted by parking minimums.

Maximum Number of Parking Spaces	
<b>Retail</b>	maximum 1.5 per 1,000 SF
<b>Office</b>	maximum 1.1 per 1,000 SF
<b>R&amp;D</b>	maximum 0.8 per 1,000 SF
<b>Industrial</b>	maximum 0.5 per 1,000 SF
<b>Residential</b>	maximum 0.75 per dwelling unit minimum .25 per dwelling unit

### Flood Resilience and Urban Heat Island Reduction

The following resilience standards aim to mitigate impacts from future flood and heat-related climate change impacts:

- Protect from anticipated 2070 10-yr (10% annual chance) SLR/SS elevation (i.e., first occupiable floors at this level)
  - First occupiable floors should be at or above this level
  - Elevate first floor no greater than 4 feet and provide additional flood protection as necessary to protect from the 2070 10-yr SLR/SS elevation.
- Recover from anticipated 2070 100-yr (1% annual chance) SLR/SS elevation
  - Locate occupiable residential use above this level
  - Elevate critical mechanical systems and building equipment above this level
  - Use water-safe or easily replaceable materials below this level

- Require green or white roofs on areas not occupied by solar panels. Mechanical equipment must have a white roof or canopy and light-colored materials must be used for occupiable space.
- Plant shade trees at intervals of 20 to 30 feet, either on the public sidewalk or within raised green front yards.
- Incorporate other measures as recommended through Climate Change Preparedness and Resilience (CCPR) plan and Climate Resilience Zoning Task Force (CRZTF).
- Establish minimum permeable area per total lot area at 25%.

## Public Improvements

Consistency with the Alewife District Plan would be a key criterion for granting of special permits. The following incentives to achieve public improvements, including new streets and open space, include:

- Retain density bonus for land conveyed to city for public use.
- Right-of-way easements reserved and/or transferred for new roads, a pedestrian/bicycle bridge connecting the Quadrangle to the Triangle, and linear open space as identified in the plan.



The North Bank Bridge, a pedestrian/bicycle bridge, connects Cambridge to Boston.

## Elevated Walkways

One of the primary reasons for zoning reform in Alewife is the necessity to balance flood resilience standards with street activation and district walkability. This plan proposes the use of an elevated walkway to mitigate the negative impacts on the streetscape associated with elevating occupiable floors. Conditions for a publicly-accessible elevated walkway are as follows:

- Locate at level of building's first occupiable floor.
- Elevated walkways should be 12 feet wide.
- Access should be provided where elevated walkways meet parcel boundaries, plus additional stairs and accessible ramps required at a maximum of every 200 feet. Stairs and ramps are to be within the 12-foot width.

- Maintain a 5-foot minimum pedestrian passage zone.
- Where an elevated walkway exists on an adjacent site, align walking surfaces or provide smooth transition.
- Provide a 12-foot wide architectural canopy over elevated walkways with at least 12 feet clear headroom.
- No enclosed space may occupy the elevated walkway.
- Non-conditioned uses and parking are allowed below the elevated walkway.



An artistic rendering shows the grade-separated bicycle lane with elevated walkways within the Quadrangle.

## Alewife Zoning Districts

The plan proposes seven zoning districts to align with the study's subdistricts. The Quadrangle subdistrict is broken down into three zoning districts: Mixed-Use Light Industrial, Residential, and Mixed-Use. The following section identifies specific zoning recommendation to achieve the goals identified in this plan for each subdistrict.

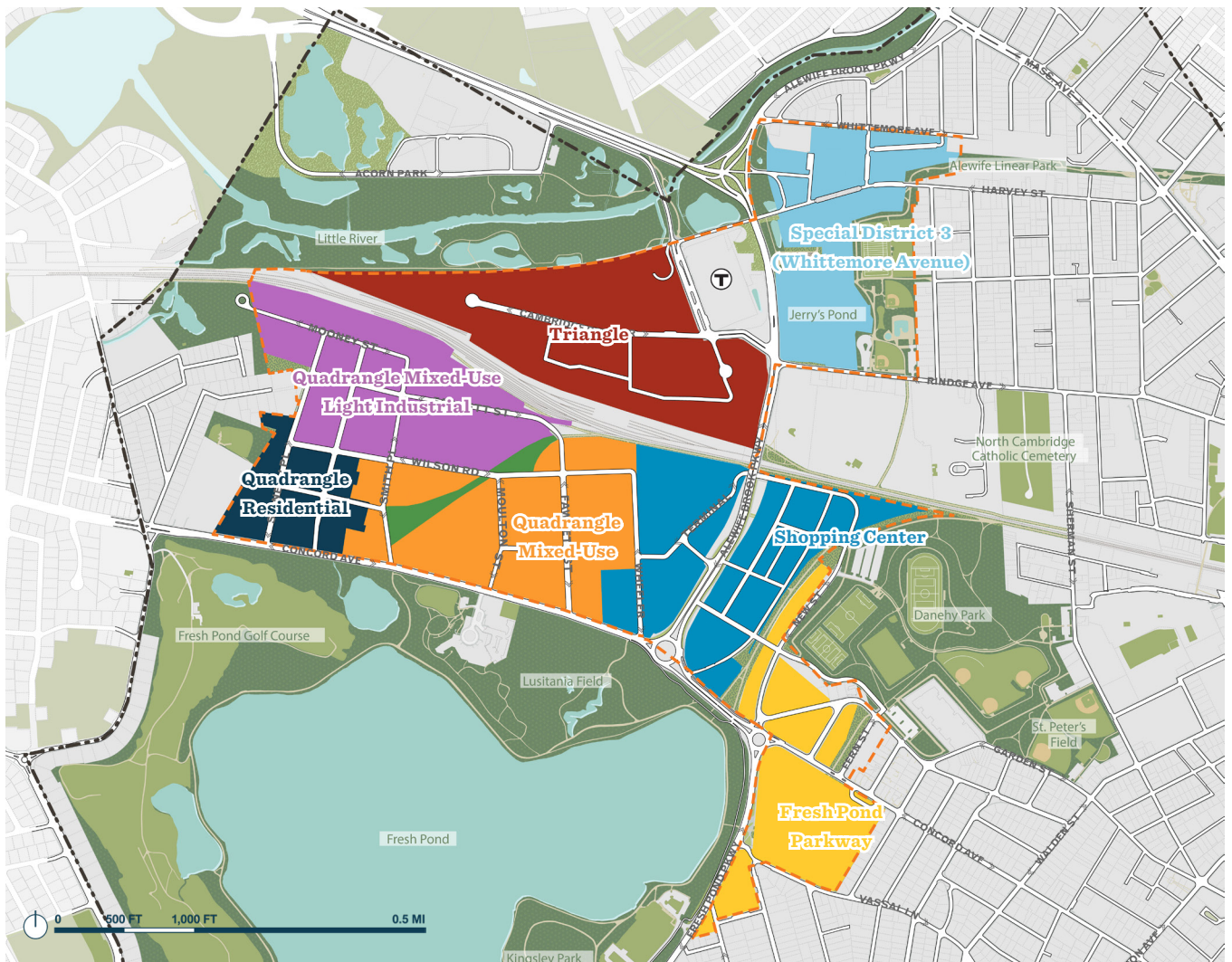



Subdistrict Development Objectives

Subdistrict	Development Objectives
<b>Quadrangle Residential Zone</b>	Transition over time to mid-rise multifamily/townhouse residential development Taller multifamily developments along Concord Avenue Promote neighborhood supporting retail along Concord Avenue and Wilson Road. Public connections to Rafferty Park
<b>Quadrangle Mixed-Use Light Industrial Zone</b>	Light industrial at ground floors of commercial buildings with appropriate floor-to-ceiling heights (see Economy Recommendations on page 148) Light industrial “showroom” or retail component along Wilson Road and Smith Place Buffer Cambridge Highlands with lower density residential and vegetated buffer Elevate first floors and create a raised, continuous, publicly-accessible walkway with active ground floor space along Smith Place and Wilson Road
<b>Quadrangle Mixed-Use Zone</b>	Mix of commercial and residential development at current allowed density Elevate first floors and create a raised, continuous, publicly-accessible walkway with active ground floor space along Smith Place and Wilson Road Encourage commercial uses along Smith Place as a buffer between residential uses and truck traffic leading to the Mixed-Use Light Industrial Zone.
<b>Triangle Zone</b>	Mix of commercial and residential development at current allowed density Promote neighborhood supporting retail or active space along Cambridgepark Drive and Alewife Brook Parkway Allow building height up to 125 feet to take advantage of the proximity to the Alewife MBTA Station
<b>Shopping Center Zone</b>	Phased, mixed-use redevelopment at current allowed density, approximately 50-60% residential, 20-30% office, 10-20% retail Create an “Alewife Square” as a focal civic space for the entire district, with pedestrian/bicycle connections Create internal street grid and expand open space along Watertown Path Retain 45,000+ SF grocery store
<b>Whittemore Avenue (Special District 3) Zone</b>	Phased, mixed-use redevelopment at current allowed density, approximately 65% residential, 35% commercial Restore open space around Jerry’s Pond for public use and stormwater retention through private (non-city) investment Internal street grid and pedestrian/bicycle connections Additional height and density in exchange for restoration of open space around Jerry’s Pond
<b>Fresh Pond Parkway Zone</b>	Residential development, with ground-floor neighborhood supporting retail or active space along Fresh Pond Parkway and Concord Avenue Curb cuts are discouraged along Fresh Pond Parkway and Concord Avenue Allow modest additional height in exchange for public open space connections

Current Alewife Overlay Zoning (FARs/Heights allowed by AOD Special Permit)

Subdistrict	AOD-1 (Quad NW)	AOD-2 (Quad NE)	AOD-3 (Quad SW)	AOD-4 (Quad SE)	AOD-5 (Shopping)	AOD-6 (Triangle)
<b>Base Zoning</b>	IB-2	IB-2	O-1	O-1	BA	O-2A
<b>Res. FAR</b>	1.50	1.50	2.00	2.00	2.001	2.00
<b>Non-res. FAR</b>	1.50	1.50	1.50	1.50	1.25 <sup>1</sup>	1.75
<b>Res. Height</b>	65'-80' <sup>2,3</sup>	85'-105' <sup>2</sup>	65'-80' <sup>2,3</sup>	85'-105' <sup>2</sup>	85'-105' <sup>2</sup>	105'-125' <sup>2</sup>
<b>Non-res. Height</b>	55' <sup>3</sup>	70'	55' <sup>3</sup>	70'	70'	85'

1 20%-50% residential required if GFA exceeds 100,000sf; first 225,000sf of non-residential must be retail.

2 Additional height only to accommodate FAR bonus for public improvements; additional limitations apply to taller floorplates.

3 Reduced to 35' within 100 linear feet of a residential or open space district; to 45' within 200 linear feet of a residential or open space district.

Note: All residential development eligible for 30% inclusionary housing density bonus.

Recommended Alewife Overlay Zoning (FARs/Heights allowed by AOD Special Permit except where noted)

Subdistrict	Quad-Residential	Quad-Light Industrial	Quad-Mixed Use	Shopping Center	Triangle
<b>Base Zoning</b>	O-1	IB-2	O-1	BA	O-2A
<b>Res. FAR</b>	2.0	1.50	2.00 <sup>1</sup>	2.00 <sup>2</sup>	2.00
<b>Non-res. FAR</b>	1.5 <sup>3</sup>	1.50 <sup>4</sup>	1.50 <sup>1</sup>	1.25 <sup>2</sup>	1.75
<b>Res. Height<sup>5</sup></b>	65'	65' <sup>6</sup>	85'	85'	125'
<b>Non-res. Height<sup>5</sup></b>	55' <sup>6</sup>	85' <sup>6</sup>	85'	85'	85'

1 Mixed-use development allowed at residential FAR, but non-residential component must conform to non-residential FAR limit.

2 Subject to master plan approval for mixed-use development, approx. 50-60% residential, 20-30% office, 10-20% retail (including grocery store).

3 Residential standards applicable to institutional uses, artist studios, and ground-floor retail.

4 FAR exemption for light industry uses at ground story.

5 Heights calculated from 2070 "protect" flood elevation

6 Reduced to 35' within 100 linear feet of a residential or open space district; to 45' within 200 linear feet of a residential or open space district.

Note: All residential development eligible for 30% inclusionary housing density bonus.

Whittemore Avenue District (Special District 3)

	Current Zoning	Recommended Zoning
<b>Maximum FAR</b>	0.45	0.45 + bonus for public open space improvements
<b>Maximum GFA in District</b>	782,500 SF	782,500 SF + bonus for public open space improvements
<b>Minimum Lot Area Per Dwelling Unit</b>	2,500 SF/unit	May be reduced with Planning Board master plan special permit approval
<b>Maximum Height</b>	55' generally Step-down to 35' near public open space Increase to 70' near Alewife Brook Parkway	70' with Planning Board master plan special permit approval including public open space improvements <sup>1</sup>

<sup>1</sup> Heights calculated from 2070 “protect” flood elevation

*Note: All residential development eligible for 30% inclusionary housing density bonus.*

Fresh Pond Parkway (new overlay district)

	Current Zoning	Recommended Zoning
<b>Base Districts</b>	Res. B, Res. C-1, Res. C-1A, BA, IA-1	No change
<b>Maximum FAR</b>	Range: 0.75-1.75	2:1 GFA bonus by special permit for public open space connections and improvements
<b>Maximum Height</b>	Range: 35'-45'	Up to 10' additional height by special permit for public open space connections and improvements <sup>1</sup>

<sup>1</sup> Heights calculated from 2070 “protect” flood elevation

*Note: All residential development eligible for 30% inclusionary housing density bonus.*





Neighborhood

West Cambridge

Strawberry Hill

---

## Acknowledgments

### Alewife Working Group

William Ahern, Alewife Business Association  
Doug Brown, West Cambridge  
James Butler, Cambridge Self Storage  
John DiGiovanni, Trinity Property Management  
Mark DiOrio, The Bulfinch Companies  
Margaret Drury, North Cambridge  
Karen Dumaine, Alewife Transportation Management Association  
Margaret Gadon, West Cambridge  
Jennifer Gilbert, North Cambridge  
Eric Grunebaum, North Cambridge  
Catherine Preston Connolly, Planning Board  
Tom Ragno, King Street Properties  
Sam Stern, West Cambridge  
Geoff Wood, North Cambridge  
Melissa Zapinelli, Alewife Transportation Management Association

### Envision Cambridge Advisory Committee

Ruth Allen, Paddy's Lunch  
Marlinia Antoine, The Port  
Josh Gerber, 1369 Coffee Housset  
Frank Gerratana, Cambridgeport  
Bill Kane, BioMed Realty Trust  
Zeyneb Magavi, Strawberry Hill  
Joseph Maguire, Alexandria Real Estate  
Risa Mednick, Transition House  
Alexandra Offiong, Harvard University  
Ebi Poweigha, The Port  
Zuleka Queen-Postell, The Port  
Ruth Ryals, Neighborhood Nine  
Tom Sieniewicz, Planning Board  
Bethany Stevens, East Cambridge  
Tom Stohlman, West Cambridge  
Jon Alvarez, MIT  
Matthew Wallace, Berry Line  
Robert Winters, Mid-Cambridge

### Engagement and Communications Working Group

Debbie Bonilla, Mid-Cambridge  
Phyllis Bretholtz, Mid-Cambridge  
Justin Crane, North Cambridge  
Elaine DeRosa, Cambridge Economic Opportunity Committee  
Tara Greco, Neighborhood Nine  
Eryn Johnson, Community Art Center  
Justin Kang, City Awake  
Sarah Kennedy, Cambridge Chamber of Commerce  
Ben Peterson, Wellington-Harrington  
Zuleka Queen-Postell, The Port  
Jeenal Sawla, Mid-Cambridge  
Cathie Zusy, Cambridgeport

### Climate and Environment Working Group

Maggie Booz, Strawberry Hill  
Maxwell Cohen, North Cambridge  
Henrietta Davis, Cambridgeport, Former Mayor  
Sophia Emperador, North Cambridge  
Cynthia Hibbard, Mid-Cambridge  
Zeyneb Magavi, Strawberry Hill  
Emily Myron, Cambridgeport  
Mike Nakagawa, North Cambridge  
Julie Newman, MIT  
Christopher Nielson, Mid-Cambridge  
Steven Nutter, Green Cambridge  
Abigail Regitsky, Cambridge Highlands  
Julianne Sammut, Neighborhood Nine  
Claire Santoro, Agassiz  
Joanne Scheuble, East Cambridge  
Juliet Stone, Riverside  
Henry Vandermark, Neighborhood Nine  
Matthew Wallace, Berry Line  
Jules Williams, Riverside

### Economy Working Group

Chris Barr, Biogen  
Tony Brooks, Coast Café  
Sarah Gallop, MIT  
Josh Gerber, 1369 Coffee House  
Theresa Hamacher, Neighborhood Nine  
Dave Holtz, Wellington-Harrington  
Denise Jillson, Harvard Square Business Association  
Jay Kiely, Forest City  
Daniel Lander, West Cambridge  
Ivy Moylan, Brattle Film Foundation  
Gina Plata, Just-A-Start  
Ebi Poweigha, The Port  
Ruth Ryals, Neighborhood Nine  
Daniel Shenfeld, Cambridgeport  
Ottavio Siani, Mid-Cambridge  
Saul Tannenbaum, Cambridgeport  
Mary Ting Hyatt, Bagelsaurus  
Ty Wilson, CustomMade

### Housing Working Group

Leonardi Aray, Strawberry Hill  
Mark Boyes-Watson, Cambridgeport  
Kelley Brown, MIT  
Kathryn Carlson, East Cambridge  
Steven Cohen, Mid-Cambridge  
Lauren Curry, Just-A-Start  
Lee Farris, The Port  
Bob Flack, Twining Properties  
Anthony Galluccio, Mid-Cambridge, Former Mayor and  
State Senator  
Esther Hanig, The Port  
Sean Hope, Hope Legal  
Jesse Kanson-Benanav, Wellington-Harrington  
Monique King, Cambridgeport  
Tom Lorello, Heading Home  
Eva Martin Blythe, YWCA  
Margaret Moran, Cambridge Housing Authority  
Deborah Morse, Agassiz  
Cheryl-Ann Pizza-Zeoli, Wellington-Harrington  
Zuleka Queen-Postell, The Port  
Susan Schlesinger, Cambridgeport  
Ellen Shachter, Cambridge and Somerville Legal  
Services  
Robert Winters, Mid-Cambridge

### Mobility Working Group

Dave Allan, Cambridgeport  
Ruth Allen, Neighborhood Nine  
Michelle Danila, North Cambridge  
Rachel Dias Carlson, Wellington-Harrington  
Chris Featherman, Neighborhood Nine  
Nate Fillmore, East Cambridge  
John Gintell, Mid-Cambridge  
Greg Heidelberg, The Port  
Mark Jensen, West Cambridge  
Caitlin McMurtry, Riverside  
Steve Miller, Cambridgeport  
Rob Ricchi, Agassiz  
Ruthann Rudel, North Cambridge  
Emma Sandoe, North Cambridge  
Melissa Shakro, MIT  
Bethany Stevens, East Cambridge  
Stacy Thompson, Livable Streets Alliance  
Annie Tuan, Mid-Cambridge  
Dustin Weigl, Cambridgeport

## City Staff

### Community Development Department

Iram Farooq, Assistant City Manager  
Sandra Clarke, Deputy Director  
Cassie Arnaud  
Tegin Bennett  
Suzannah Bigolin  
John Bolduc  
Gary Chan  
Cliff Cook  
Bronwyn Cooke  
Chris Cotter  
Stuart Dash  
Bill Deignan  
Christina DiLisio  
Seth Federspiel  
Stephanie Groll  
Lisa Hemmerle  
Wendell Joseph  
Drew Kane  
Jennifer Lawrence  
Bridget Martin  
Brendan Monroe  
Melissa Peters  
Susanne Rasmussen  
Jeff Roberts  
Pardis Saffari  
Cara Seiderman  
Erik Thorkildsen

### Assessing Department

Robert Reardon, Director

### Cambridge Arts Council

Jason Weeks, Executive Director  
Lillian Hsu

### Cambridge Historical Commission

Charles Sullivan, Executive Director

### Department of Public Works

Owen O’Riordan, Commissioner  
Jerry Friedman  
Michael Orr  
Kathy Watkins

### Finance Department

David Kale, Assistant City Manager

### Human Services Department

Ellen Semonoff, Assistant City Manager  
Allyson Allen  
Shelly Chevalier  
Michelle Godfrey  
Elizabeth Mengers  
Susan Mintz  
Carole Sousa  
Sue Walsh

### Police Department

Branville G. Bard, Jr., Commissioner  
Matt Nelson

### Public Health Department

Claude-Alix Jacob, Chief Public Health Officer  
Joséfine Wendel

### Public Information Office

Lee Gianetti, Director

### School Department

Dr. Kenneth Salim, Superintendent  
James Maloney  
Claire Spinner

### Traffic, Parking, and Transportation

Joseph Barr, Director  
Brooke McKenna  
Adam Shulman

### Water Department

Sam Corda, Director  
Frederick Centanni  
David Kaplan  
Tim MacDonald

Special thanks to the Community  
Engagement Team.



## Consultant Team

Utile  
HR&A Advisors  
Interboro Partners  
Nelson\Nygaard  
Buro Happold  
Donahue Institute at the University of Massachusetts,  
Boston  
McMahon Associates

## Contact

Melissa Peters, AICP, Project Manager  
Cambridge Community Development Department  
344 Broadway  
Cambridge, MA 02139  
mpeters@cambridgema.gov  
(617) 349-4605  
envision.cambridgema.gov

---

## Photo Credits

All photos, historical documents, and images courtesy of the City of Cambridge or Utile, Inc. except as noted. All photos and images reproduced in this document have been checked for copyrights. If a photo or image is posted, it is because display rights have been obtained from the copyright holder, it is known to be in the public domain, or clear copyright/ownership could not be established. It is not the intention of this document to willingly violate copyrights or intellectual ownership in any way. If it is determined that a photo or image appearing in this document is copyrighted by others, it will be removed.

[Alewife Fishbook](#) page 20, page 22

[Cambridge Community Development Department](#) page 45 center, page 107, page 111, page 127, page 131

[Cambridge Historical Commission](#) page 20

[Cambridge Water Department](#) page 44 right, page 64, page 65

[Centralrockgym.com](#) page 79 center

[Cloudinary](#) page 116

[Flickr / Flickr User bujcich](#) page 46, page 118

[Flickr / Flickr User Daniel X. O'Neil](#) page 137

[Flickr / Flickr User Payton Chung](#) page 134

[Freefoodboston.wordpress.com](#) page 144

[Northeastern.edu](#) page 79 left

[Samuel F. Batchelder](#) page 21

[Socialsecurityoffices.info](#) page 78 right

[Wikipedia Commons / Wikimedia User ArnoldReinhold](#) page 49

[Wikipedia / Creative Commons](#) page 12, page 46, page 45 left, page 45 right

[Wikipedia Commons / Wikimedia User Pi.1415926535](#) page 52, page 55



ENVISION  
CAMBRIDGE

ENVISION  
CAMBRIDGE

Cambridge, MA  
12/15/11

SPR  
ARE

QUIN DOORQUIN

West Central Ave

Cambridge

Fresh Pond

Cambridge Highlands

Alvord Reservation

Lushan Field

Fresh Pond Golf Course



ENVISION  
CAMBRIDGE