

The enclosed City of Cambridge Construction and Operating Procedures are provided to outline the CWD's (Cambridge Water Department) minimum criteria for construction of utilities and infrastructure within city limits. It is the duty of the property owner to verify and obtain all applicable permits. All water works construction projects shall follow these procedures.

The city's authorized representatives must approve the proposed construction; written permits must be obtained from appropriate agencies, and all permit fees paid before construction begins. Contractors working on city roads, right of ways, or city owned utilities must be bonded with the City of Cambridge.

Final definitive plans shall conform in accordance with the latest edition of the rules and regulations of the City of Cambridge and these procedures, and shall receive approval of the appropriate officials before improvements are made.

These practices were prepared with the intent of obtaining the highest quality of construction possible, consistent with accepted industry practices and specifications.

A minimum of 72 hours notice shall be given to the CWD prior to starting construction. Emergency work will be approved by the Distribution Manager or designated representative.

The Contractor shall be responsible for the preparation and submittal of three sets of blue line record drawings to the CWD within 60 days after completion of construction. Record drawings shall be a full set of drawings showing all details of the construction. A registered professional engineer shall certify record drawings true and correct.

Copies of the Construction and Operating Procedures may be obtained from the Cambridge Water Department, 250 Fresh Pond Parkway, Cambridge, MA 02138.

## TABLE OF CONTENTS

### **ARTICLE 1. CONSTRUCTION AND MATERIAL STANDARDS**

	Page
Section 1. Definitions	5 - 9
Section 2. Water Distribution System	9 - 10
Section 3. System Connections	10
Section 4. Contractor Responsibilities	10
Section 5. Pipe	10
Section 6. Pipe Joints	10
Section 7. Fittings	10
Section 8. Couplings	10
Section 9. Gate Valves	11
Section 10. Butterfly Valves	11
Section 11. Tapping Sleeve & Valve	11
Section 12. Gate Boxes	11
Section 13. Hydrants	11
Section 14. Hydrant Tees (Anchoring Tees)	12
Section 15. Service Piping & Connections	12
Section 16. Corporations	12
Section 17. Curb Stops	12
Section 18. Service Boxes	12
Section 19. Thrust Blocking	12
Section 20. Mechanical Joint Restraint	12 - 13
Section 21. Electrical Grounding	13
Section 22. Pressure & Leakage Test	13 - 14
Section 23. Disinfecting & Flushing	14

### **ARTICLE 11. USE OF WATER AND WATER FACILITIES**

Section 1. Pricing Structure	14
Section 2. Jurisdiction	14
Section 3. Ownership	14
Section 4. Public Water Mains	14
Section 5. Private Water Mains	14
Section 6. Applicable Regulations & Codes	15
Section 7. Water Conservation & Emergencies	15
Section 8. Water Main Extensions & Relocation	15
Section 9. Hydrants	16 - 17
Section 10. Water-cooled Air Conditioning & Refrigeration	17
Section 11. Fountain & Irrigation Systems	18

### **ARTICLE 111. WATER SERVICE**

Section 1. Application for Water Service	19
Section 2. Rates & Fees	19
Section 3. Water Service Pipes	19 - 21
Section 4. Meters & Meter Testing	21 - 22
Section 5. Repair, Maintenance & Thawing	22
Section 6. Shut Off, Termination, Abandonment & Let-On	23

**TABLE OF CONTENTS CONTINUED**

**ARTICLE IV. PRIVATE FIRE PROTECTION**

	Page
Section 1. Application for Fire Service Line	24
Section 2. Fire Lines	24 - 25
Section 3. Repairs, Maintenance & Thawing	25
Section 4. Shut-Off, Termination, Abandonment & Let-On	25 - 26

**ARTICLE V. CROSS-CONNECTION CONTROL**

Section 1. Back Flow Preventor	26
Section 2. Cross-Connection Inspection	26 - 27
Section 3. Cross-Connection Elimination	27
Section 4. Owner's Liability	27

**ARTICLE VI. ENFORCEMENT**

Section 1. Inspection	27 - 28
Section 2. Enforcement	28
Section 3. Liability	29
Section 4. Penalties	30

**ARTICLE VII. APPELLATE PROCEDURES**

Section 1. Immediate Right to a Hearing for Shut-Off or Termination	31
Section 2. Appeals from CWD Actions Including Shut-Off or Termination	31 - 32

**ARTICLE VIII. ADOPTION**

Section 1. Supersedes Prior Procedures	33
Section 2. Severability	33
Section 3. Right to Amend	33
Section 4. Adoption	??

**APPENDIX A**

Special Service Fees	34 - 38
----------------------	---------

**APPENDIX B**

Water Works Construction Permits	39 - 48
----------------------------------	---------

**APPENDIX C**

Disinfecting Water Mains	49 - 52
--------------------------	---------

**APPENDIX D**

Water Main Installation Details	53
---------------------------------	----

**APPENDIX E**

City of Cambridge Permit Contacts	54 - 56
-----------------------------------	---------

**APPENDIX F**

	57 - 58
--	---------

Demolition

**APPENDIX G**

Hydrostatic Testing

59 - 61

**APPENDIX H**

Dig Safe

62 - 66

**APPENDIX I**

Trenching, Backfill, and Compaction

67 - 75

**APPENDIX J**

Technical Specifications

76 - 100

# ARTICLE 1

## SECTION 1. DEFINITIONS

<b>AWWA</b>	American Water Works Association
<b>ANSI</b>	American National Standard Institute
<b>ASTM</b>	American Society for Testing and Materials
<b>ASCE</b>	American Society of Civil Engineers
<b>ABANDONMENT</b>	The condition in which water service to a building has been discontinued at the owner's request for a period of at least one year and the owner has made no commitment as to possible future use.
<b>APPLICANT</b>	Any person applying for water service or for a water main extension, replacement or relocation.
<b>APPLICATION FOR WATER WORKS CONSTRUCTION PERMIT</b>	The CWD form completed and signed by an owner or by the owner's agent and submitted to the CWD prior to construction of a water service pipe or a fire pipe from a public water main.
<b>AS BUILTS</b>	CWD requires specific measurements from property lines to water mains, hydrants and service boxes on all valves. These measurements should conform to the square tie measurement practice (i.e. ninety degrees) . Also, as-built plans should specify the degree, size and type of any fittings used during water main or service installation. The plans should also reflect any field notes taken by the resident engineer during installation regarding such issues as thrust blocks, insulation , and backfill material used, elevations and grades.
<b>BACKFLOW</b>	The reversal of the normal flow of water or other liquids caused by back pressure or back siphonage.
<b>BACKFLOW PREVENTOR</b>	A device or means to prevent backflow.
<b>BUILDING</b>	Any structure used for human occupancy, employment, and recreational or other purposes.
<b>CITY</b>	City of Cambridge, Massachusetts
<b>COMBINED SERVICE</b>	An existing service pipe that is used to provide both water service and private Fire protection service. New installations of combined service are not permitted.
<b>CONSUMPTION</b>	The amount of water used, as measured by a meter or as estimated by the CWD in accordance with its billing.
<b>CONTRACTOR</b>	A person who performs plumbing, paving, sidewalk, sewer, water or other work.
<b>CROSS-CONNECTION</b>	Any physical or potential connection or arrangement between two separate Systems, one of which contains potable water and the other water of unknown or questionable safety or steam, gas or chemicals, allowing flow from one system. To the other.
<b>CUSTOMER</b>	The person listed in the CWD records as the party responsible for payment of bills for water service to a property.
<b>Control Density Fill (CDF – Flow fill)</b>	CDF is a flowable mixture of aggregate and cementitious material containing sufficient Portland cement to develop a 28-day compressive strength of between 50 to 150 psi, that compacts upon backfill placement.

<b>CTD</b>	Cambridge Traffic Department
<b>CFD</b>	Cambridge Fire Department
<b>CWD</b>	Cambridge Water Department
<b>DEMOLITION</b>	A partial or full dismantling of a structure. A demolition permit is necessary to demolish or to remove all detached structures as required by 780 CMR s 113; Ch. 2.78 Cambridge Municipal Code. A Demolition permit is required by the building code and by provisions of the Historical Buildings Ordinance for the demolition or moving of all buildings and structures of significant portions.
<b>DESIGN CRITERIA</b>	Standards for design used by the CWD for construction and rehabilitation of public water mains, water service pipes and fire pipes.
<b>DEP</b>	Department of Environmental Protection
<b>DISCONTINUANCE</b>	The cessation of water services at the premises at the request of an owner or Customer.
<b>DPW</b>	Department of Public Works
<b>EASEMENT</b>	An acquired legal right for the specific use of land owned and maintained by Others.
<b>FLY ASH</b>	Fly ash shall conform to the requirements of ASTM C618, Class F. Fly ash as a percent by weight of total cementitious material, shall not be permitted in use around water mains or services.
<b>FIRE PUMP TEST</b>	A means for contractors to conduct a test to determine whether a fire pump system is functioning properly as required by M.G.L. ch. 310: CMR 22.22.13.08
<b>FIRE PIPE</b>	The private water piping, control valve and appurtenances installed solely to furnish water for extinguishing fires.
<b>FIRE FLOW TEST</b>	The measurement of flow from a hydrant performed by the CWD in accordance with generally accepted engineering practices.
<b>HYDRANT</b>	A device connected to a public water main for the purpose of extinguishing fires or other authorized purpose.
<b>HYDRANT PERMITS</b>	A written permit granted by the CWD for the temporary use of a hydrant.
<b>ISD</b>	Inspectional Services Department
<b>LET ON</b>	The opening of a control valve to initiate or restore water service.
<b>MASTER METER</b>	A meter used for billing purposes serving a building or group of buildings.
<b>METER</b>	An instrument for measuring the flow of water.
<b>METER PIT</b>	An underground vault enclosing a meter.
<b>MWRA</b>	Massachusetts Water Resources Authority
<b>OWNER</b>	A person who alone, or jointly or severally with others, has the legal title to any premises or has care, charge or control of any premises as agent, executor, administrator, trustee, lessee or guardian of the estate of the holder of legal title.
<b>PERSON</b>	Any individual, firm, company, partnership, association, society, corporation, group or any political subdivision of the Commonwealth.

<b>PLUMBER</b>	A person licensed as a plumber by the Commonwealth of Massachusetts.
<b>POTABLE WATER</b>	Water fit for human consumption in conformance with the regulations of the Massachusetts Department of Environmental Protection.
<b>PRIVATE FIRE PROTECTION</b>	Private water mains, fire pipes and other appurtenances installed for the purpose of fire protection at a particular premises.
<b>PUBLIC FIRE PROTECTION</b>	The public water mains, hydrants and appurtenances installed for the purpose of fire protection in a public way, city-owned easement or private way open to public travel.
<b>PUBLIC WATER MAIN</b>	The piping and associated valves, hydrants and appurtenances installed in a public way, CWD/city-owned easement or private way opens to public travel for the purpose of supplying water to one or more customers or for public fire protection.
<b>RESIDENTIAL METER</b>	A meter two inches in size or smaller used to measure the flow of water to a predominantly residential property.
<b>SHUT OFF</b>	The closing of a control valve to temporarily stop water service or to terminate water service.
<b>TERMINATION</b>	The cessation of water service pursuant to the CWD's billing, termination and appeal regulations or for violation of these regulations.
<b>USER</b>	Any person who obtains water from a public water main or a private water main supplied from a public water main.
<b>WATER SERVICES</b>	The readiness to supply or actual supplying of water to premises in which a water service pipe or fire pipe has been installed. Water service may also mean a water service pipe.
<b>WATER SERVICE PIPE</b>	The connection, piping and associated valves and appurtenances that extend from a public water main to a building or property for the purpose of supplying water.

## ARTICLE 1 - CONSTRUCTION AND MATERIAL STANDARDS

### SECTION 2: WATER DISTRIBUTION SYSTEM

The piping system shall meet the following minimum requirements and shall be subject to the approval of the Cambridge Water Department (CWD):

- A. Pipe shall be cement lined, tar coated, Ductile Iron, Class 52.
- B. The CFD and the CWD shall approve hydrant location.
- C. Every hydrant shall be equipped with a 6-inch shut-off valve, bolted or anchored to the hydrant tee.
- D. Line valves shall be spaced at not more than 500 feet and as determined by the CWD.
- E. In new construction, every intersection shall be valved “(3) three-ways” if a tee is used; and “(4) four-way” if a cross is used.
- F. Dead ends shall be avoided by the looping of all water mains whenever practical.
- G. All water mains and service pipe shall be laid in a trench separate from any other utility. The horizontal distance between water mains or service pipe and any other utility (gas, electric, telephone, etc.) shall be at a minimum no less than two (2) feet, vertical distance shall be no less than (1) foot and no less than ten (10) feet from a sanitary sewer or surface water drain. **DEP regulation #310CMR22.19** distribution system requirements.

#### **Relation to water mains and sewers:**

**Horizontal Separation:** Whenever possible sewers shall be laid at a minimum of at least 10 feet (3.0m), horizontally, from any existing or proposed water main. Should local conditions prevent a lateral separation of 10 feet, a sewer may be laid closer than 10 feet to a water main if:

- 1. It is laid in a separate trench, or if;
- 2. It is laid in the same trench with the water mains located at one side on a bench of undisturbed earth, and if;
- 3. In either case the elevation of the top (crown) of the sewer is at least 18-inches (46cm) below the bottom (invert) of the water main.

**Vertical Separation:** Whenever sewers must cross under water mains, the sewer shall be laid at such an elevation that the top of the sewer is at least 18-inches (46cm) below the bottom of the water main. When the elevation of the sewer cannot be varied to meet the above requirements, the water main shall be relocated to provide this separation or re-constructed with mechanical-joint pipe for a distance of 10 feet (3.0m) on each side of the sewer. One full length of water main should be centered over the sewer so that both joints will be as far from the sewer as possible.

When it is impossible to obtain horizontal and/or vertical separation as stipulated above, both the water main and sewer shall be constructed of mechanical-joint cement lined ductile iron pipe or other equivalent based on water-tightness and structural soundness. Both pipes shall be pressure tested by an approved method to assure water-tightness.

- H. **The minimum bury shall be 4 feet** for all water lines. **Unless approved by CWD.**
- I. All material shall be in accordance with the “Material Standards” attached hereto.
- J. All material shall be new and shall be of the type currently used by the CWD.
- K. All construction shall be in accordance with the latest “Commonwealth of Massachusetts, Department of Public Works - Standard Specifications for Highways and Bridges”, the “American Water Works Association Standards” and in accordance with the current practice of the CWD.



### **SECTION 3: SYSTEM CONNECTIONS**

Connections to the existing water distribution system must be approved by the CWD. Please refer to **Appendix B** for Water Works Construction Permit.

### **SECTION 4: CONTRACTOR RESPONSIBILITIES**

The Contractor shall not operate any hydrants, valves, curb stops or corporations, nor shall they draw any water from the system, without specific approval of the CWD. Only CWD personnel will operate valves, hydrants, corporations and curb stops unless otherwise directed by the CWD. Please refer to **Appendix B** for appropriate permit.

### **SECTION 5: PIPE**

Distribution system pipe shall be at least 8 inches in diameter, shall be class 52 ductile iron pipe, cement lined and tar coated per AWWA specifications. The pipe shall be as manufactured by the U.S. Pipe and Foundry Company, Griffin Pipe Company or an approved equal by the CWD.

Pipe used for hydrant branches shall be at least 6 inches in diameter and shall meet the above specifications and shall be restrained the entire length of the branch.

Pipe used for fire lines shall be sized by the owner's engineer and must meet the above specification.

### **SECTION 6: PIPE JOINTS**

Push-on type joints are recommended on straight runs of pipe. Gaskets must be standard for pipe used and be suitable to the CWD. The CWD may require, under certain conditions, that restrained type joints be used. The method of restraining may be either of an interlocking type or mechanical joints restraint (**see Section 20 of this Article**) or as specified by the CWD.

### **SECTION 7: FITTINGS**

Ductile iron fittings must be used and shall be cement lined. Fittings are required to be equipped with a mechanical joint restraint as specified in **Article 1, Section 20**, unless otherwise specified by the CWD. Mechanical joint fittings in sizes 4-inch through 12-inch shall be ductile iron compact fittings and rated for 350 *psi* working pressure. All Nuts and bolts shall be of a type equal to ductile iron or KOR-10 steel T-bolts and nuts.

### **SECTION 8: WIDE RANGE TRANSITION COUPLINGS**

Wide Range Transition Couplings shall be of a type equal to Smith Blair Style 421, Hymax 2 or Romac Alpha Style or an approved equal.

### **SECTION 9: GATE VALVES**

Gate valves shall be resilient seated and shall meet the requirements of AWWA C-509. Valves shall be rated for 200 *psi* minimum working pressure. Valves shall be **Ductile Iron** body, bronze mounted, resilient seated, non-rising stem type fitted with "O" ring seals. The operating nut shall be 2-inches square. Bolts on the bonnet and stuffing box shall be stainless steel (316 stainless steel). Valves shall have mechanical joint ends and shall be equal to ANSI/AWWA C11/A21.11. **Valves shall open right (clockwise).**

**Extensions shall be provided for all gate valves that the depth exceeds 6 feet to the top of the operating nut.**

## **SECTION 10: BUTTERFLY VALVES**

Butterfly valves for buried services shall conform to AWWA C504, except as hereinafter provided. Butterfly valves shall be rated for Class 150b and both valve operators shall be especially designed for services buried in ground and shall be of the totally enclosed type. The unit shall be permanently lubricated with grease or oil. A standard AWWA 2-inch square-operating nut shall be provided on the input shaft. **Valves shall open to the right (clockwise).**

## **SECTION 11: TAPPING SLEEVE AND VALVES**

Tapping sleeves shall be mechanical joint type and shall be Mueller H-615, American Darling 1004 or equal. Tapping valves shall meet the requirements of AWWA C500. The valves shall be flanged by mechanical joint outlets with non-rising stem and designed for vertical burial. Tapping valves shall be rated at *200 psi* working pressure and shop tested at *300 psi*. Bolts on bonnets and stuffing boxes shall be stainless steel (316 stainless steel); stuffing boxes shall be “O” ring type. The operating nut shall be 2-inches square. The valve shall be provided with oversized seat to permit use of full size cutters. Gaskets shall cover the entire flange surface. Valves shall be Mueller H-667 or equal. **Valves shall open right. (Clockwise).** Multiple taps to be three (3) feet from flange to flange. Pre-inspection is required for all taps.

## **SECTION 12. GATE BOXES**

Valve boxes shall be provided for each gate valve and tapping valve. Valves boxes shall be cast iron and of the telescopic design with two piece construction, a top with a cover and a bottom (**5-inch inside diameter 6ft length**). The top section shall have a top flange to increase the stability of the box to remain at the present height. The lower section of the box shall have a bell shaped bottom designed to enclose the operating nut and stuffing box of the valve without settling. The gate box shall come complete with a cover on which the word “**WATER**” shall be cast. The cover of the gate box shall be close fitting and substantially dirt tight and flush with the top of the box rim. Gate boxes shall be installed for each buried valve. Cast iron boxes shall be general foundry Buffalo boxes or equal.

## **SECTION 13. HYDRANTS**

Hydrants shall conform to the “standard dry barrel hydrants” ANSI/AWWA C502 - 85. Hydrants shall be designed for *150-psi* service and for installation in a **minimum 4 ft.** covered trench. They shall **OPEN RIGHT** (clockwise) and must be marked with an arrow and the word **OPEN** to indicate the direction of turn of the stem to open the hydrant. They shall have one steamer connection, 4-1/2-inch diameter and two 2-1/2 inch hose nozzles all with National Standard Thread (NST). Hydrant inlet opening on shoe shall have mechanical joints for accepting 6-inch ductile iron pipe. Hydrants shall have a compression type main valve, opening against and closing with water pressure. The main valve opening at the base of the Hydrant shall have a minimum area of 39 square inches (5-inch minimum diameter circle). Each hydrant shall have “traffic” type ground line construction (breakaway bolts **not** acceptable) and permit 360 degree movement of the upper barrel to allow for any alignment without shutting down service and/or removing flange bolts and nuts. Hydrant operating nut shall be 1-1/2 inches, flat to point, pentagonal. Hydrants shall be hydrostatically tested as specified in AWWA C502. The length of the hydrant barrel shall be such that when installed with the proper depth of cover on the branch pipeline, the hydrant will be set with the normal ground line of the barrel within 3-inches of the actual finished ground grade surface elevation. For the most part, minimum bury length shall be 5-1/2 feet. Connecting pipes and pipe nipples between the main line tee and hydrant shall be 6-inch ductile iron conforming to the requirements for ductile iron pipe.

#### **SECTION 14. HYDRANT TEES (ANCHORING TEES)**

Hydrant tees shall be anchor type. The branch shall have a plain end with an integral gland and rotating mechanical joint restraints as specified in **Article 1, Section 20**. Mechanical joint restraint to provide a restrained connection (thrust blocks) required.

#### **SECTION 15. SERVICE PIPING & CONNECTIONS**

Service pipe shall be type "K" copper tubing, American manufactured, 1-inch minimum. All service fittings shall be extra heavy brass (**Lead Free**), manufactured by either Water Distribution Products, Cambridge Brass, Ford Meter Box Company **or equal**. **All services greater than 1-inch shall have the valve box installed at the corporation at the main.**

#### **SECTION 16. CORPORATIONS**

Corporations for 1-inch installations shall be heavy pattern, easy turning and of a type equal to **Ford FB 1000-4** (no lead brass) series. The inlet shall be an AWWA (CC) thread. The outlet shall be for a compression joint for Type-K copper. The 1-1/2 inch and 2-inch corporations shall be of a ball valve type which incorporates Teflon seats to assure self-centering of a Teflon coated bronze ball similar to a style typified by the Ford FAFB - 1000 (T-head) series or an approved equal by the CWD. The corporations shall be easy turning and non-binding. The inlet shall be an AWWA (CC) thread. The outlet shall be for a compression joint for Type-K copper. **ALL** corporations shall be subject to a sustained hydraulic pressure of *200 psi* and tested in both the open and closed positions for leakage and ease of turning. All taps **1 inch or greater** will require the use of a tapping saddle.

#### **SECTION 17. CURB STOPS**

For sizes 1-inch, the curb stops shall be a type equal to the Ford B44-444-Q (no lead brass) series or approved equal. The curb stop shall have a quarter turn stop with check, solid tee head and no waste. No curb stops with plugged solid waste shall be accepted.

#### **SECTION 18. SERVICE BOXES**

Service boxes supplied shall be "Buffalo" style, American manufactured, of a telescopic type with a length from four (4) to five (5) feet. The cover shall be made of extra grade gray iron. The arch shall accommodate up to a 1-inch curb stop. The upper section shall be made of cast iron and be equal to a "Buffalo" style 94-E upper section. **Inside diameter to be a minimum of 2-1/4-inches.**

#### **SECTION 19. THRUST BLOCKING**

Where applicable, thrust blocks shall be furnished at all tees, tapping sleeves and bends as directed or as detailed on drawings with *3,000 psi*, 1-1/2, 470 cement concrete masonry. The blocks shall be poured against undisturbed original ground and shall be so placed that pipe joints will be accessible for any possible future repairs. The other means of restraint may either be of an interlocking type or mechanical joint restraint as in **Article 1, Section 20**, as specified by the CWD and shall be installed in addition to thrust blocks as directed by the CWD.

#### **SECTION 20. MECHANICAL JOINT RESTRAINT**

Mechanical joint restraint shall be incorporated into the design of the follower gland. The restraining mechanism shall consist of individually actuated wedges that increase their resistance to pull out as pressure or external forces increase. The device shall be capable of full mechanical joint deflection during assembly and the flexibility of the joint shall be maintained after burial. The joint restraint ring and its wedging components shall be made of grade 60A2-10 ductile iron conforming to ASTM A 536-84. The wedges shall be ductile iron heat treated to a minimum hardness of 370 BHN. Dimensions of the gland shall be such that it can be used with the standardized mechanical joint bell conforming to ANSI/AWWA C111/A21.1 and ANSI/AWWA C153/A21.3 of the latest revision. Torque limiting twist off nuts shall be used to insure proper actuation of the restraining wedges. The mechanical joint restraint shall be available in the four through forty-eight inch sizes. They shall have a rated work pressure of *350 psi* in sizes sixteen inch and smaller and *250 psi* in sizes eighteen inch

through forty-eight inch. The devices shall be listed by Underwriters Laboratories up through the twenty-four inch size and approved by Factory Mutual up through the twelve-inch size. The restraint shall be the Series 1100 MEG ALUG restraint as produced by EBAA Iron, Inc. or approved equal.

### **SECTION 21. ELECTRICAL GROUNDING**

No electrical grounds shall be made on water service pipes where a driven ground rod can provide the needed grounding service as determined by the ISD. Electrical grounding must be provided in accordance with the National Electric Code.

### **SECTION 22. PRESSURE & LEAKAGE TEST**

**Appendix G** contains the AWWA Standards for the Installation of Ductile Iron Water Mains and their Appurtenances (ANSI/AWWA C600-93), including the requirements for pressure and leakage testing. The pressure and leakage tests shall be as specified in ss 301.60.L of the Standard Specifications for Highways and Bridges, AWWA Standard C600-93, ss 4.11 and **NFPA standard for underground sprinkler piping**. In general, the water pipe shall be given a pressure and leakage test in sections of approved length. For these tests, the **CONTRACTOR** shall provide a method of determining the exact amount of water being pumped into the test section and a pressure gauge. The **CONTRACTOR** shall also furnish and install suitable temporary testing plugs or caps for the pipeline; all necessary pressure pumping, pipe connections and other similar equipment; and all labor required; all without additional compensation. Prices for the appropriate pipe items shall include compensation for testing. The test equipment shall be installed by the **CONTRACTOR** in such a manner that all water entering the section under test will be measured and the pressure in the section indicated and they shall be kept in use during all tests. The scheduling of pressure and leakage tests shall be approved by the CWD and shall be attended by a CWD representative. Unless it has already been done, the section of pipe to be tested shall be filled with water of approved quality, and all air shall be expelled from the pipe.

If the section fails to pass the pressure and leakage test, the **CONTRACTOR** shall do everything necessary to locate, uncover, even to the extent of uncovering the entire section and repair or replace the defective pipe, fitting or joint all at his own expense.

**A report containing calculations and documentation pertaining to the pressure and leakage testing shall be submitted to the CWD.**

### **SECTION 23. DISINFECTING & FLUSHING**

**Appendix C** contains the AWWA Standards for Disinfecting Water Mains (ANSI/AWWA C651-92). After a section of the main has been pressure tested and found acceptable, it shall be flushed thoroughly by the **CONTRACTOR**. Flushing the completed main is to be followed by sterilization in accordance with the AWWA Standards for Disinfecting Water Mains (ANSI/AWWA C651-92). Test results for chlorine residuals for times as specified in the method of disinfecting must be submitted to the CWD. If the initial treatment fails to produce the desired result, the chlorinating procedure must be repeated. Discharge of chlorinated water shall comply with all Federal, State and Local Standards. DPW must be contacted prior to flushing. De-chlorinating facilities shall be used as required.

## ARTICLE II USE OF WATER AND WATER FACILITIES

### SECTION 1. PRICING STRUCTURE

Please refer to **Appendix A** for the Special Service Fees as adopted pursuant to Cambridge Municipal Code, 13.08.020.

### SECTION 2. JURISDICTION

All property situated within the City of Cambridge shall be eligible to receive water service from the CWD upon compliance with these Practices. The timing and methods for extending or providing service shall be at the CWD's sole discretion. The CWD's jurisdiction is from the city water main to the water meter or in cases of fire line to the street side valve. Thereafter ISD.

### SECTION 3. OWNERSHIP

All public water mains, hydrants, valves and associated appurtenances located within public ways, city-owned easements and private ways open to public travel within the city are owned by the CWD. The property owner owns the water service pipe and fire service lines from the water main into the building (including all control valves).

### SECTION 4. PUBLIC WATER MAINS

The use of all public water mains in the city, except for transmission mains of the MWRA, shall be controlled by the CWD. No person shall, without prior written authorization from the CWD, uncover, make any connections with or opening into, alter or disturb a public water main.

### SECTION 5. PRIVATE WATER MAINS

All private water mains in the City that convey water from public water mains owned by the CWD shall be controlled by the CWD, but shall be operated and maintained by their owners. The CWD may direct the owner to repair or replace a private water main, if in the judgment of the CWD such action will reduce the quantity of water lost through leaks from that main. Repairs to private water mains, including repairs required to comply with these practices, shall be made by and at the expense of the owner.

### SECTION 6. APPLICABLE REGULATIONS AND CODES

Any user of public or private water mains shall be subject to whatever rules, regulations, policies, charges, rates, fees and assessments that are from time to time established by the CWD. Any user of public or private water mains shall also be subject to applicable state and federal regulations. In instances where various regulations contain conflicting requirements, the most stringent requirements shall be met. In addition to these Practices, the most recent edition of the following rules or guidelines

shall be adhered to:

- A. Commonwealth of Massachusetts, Department of Environmental Protection, Division of Water Supply: Guidelines for Public Water Systems;
- B. Commonwealth of Massachusetts, Board of Examiners of Plumbers and Gas Fitters: Uniform State Plumbing Code and Massachusetts Fuel Gas Code (Massachusetts Plumbing Code);
- C. Commonwealth of Massachusetts, Department of Public Health: State Sanitary Code, Article I and Article II;
- D. Commonwealth of Massachusetts, Department of Environmental Protection: Drinking Water Regulations: 310 CMR Section 22;
- E. City of Cambridge: Fire Protection Code;
- F. National Fire Protection Association: National Fire Code.

## **SECTION 7. WATER CONSERVATION AND EMERGENCIES**

### ***Conservation by Users***

No user shall knowingly allow water to leak or run to unnecessary waste. **Conservation Restrictions**

Upon CWD's determination that conditions exist which so limit the water supply that unrestricted water use could endanger the adequacy of supply and the public health, safety and welfare, the Managing Director may adopt conservation restrictions in accordance with the provisions of Massachusetts General Laws Chapter 21G. Conservation restrictions shall remain in force and effect until the Managing Director determines that the conditions requiring their imposition no longer exist.

### ***Emergency Shut-Off***

Upon notification to the owner and in accordance with Massachusetts General Laws, Chapter 40, Section 41A, the CWD may shut-off water service to any premises during a drought, hurricane, conflagration or other disaster.

## **SECTION 8. WATER MAIN EXTENSIONS AND RELOCATION**

### ***Procedure for Extensions***

An applicant may propose an extension, replacement or relocation of public water mains to serve new or rehabilitated buildings. All proposed extensions, replacements or re-locations, including any tests, studies, investigations and inspections required for design, shall be subject to the approval of the CWD. All expenses, including all engineering, legal permitting, construction and inspection expenses involved in applying for and constructing an extension, replacement or relocation shall be borne by the applicant.

### ***Bonding and Approval of Contractors***

Before commencing work on any public water main extension, replacement or relocation, a contractor working for the CWD or for an owner on city-owned property or easement shall (a) file a bond with the DPW in an amount acceptable to the DPW (b) contractor must be approved by the CWD. (A deposit may be required by C.W.D.)

### ***Release Agreement***

After approval of a proposed extension, replacement or relocation of a water main and after the intended construction has been approved by the CWD, the applicant shall transfer ownership of the extended, replaced or relocated water main to the CWD through a Release Agreement in a form prescribed by the CWD. (See **Appendix B** for Release Agreement.)

### ***CWD Denial or Modification of Proposal***

The CWD may deny the request of an applicant to extend, replace or relocate a public water main if in the CWD's opinion; adequate water pressure cannot be achieved. The CWD may condition its approval of a request to extend, replace or relocate. Among other things, the CWD may require that an applicant who proposes to extend, replace or relocate a public water main, install a larger pipe size than required to serve the applicant.

### ***Water Main Replacement***

If an applicant requests a new water service pipe or fire pipe which, in the judgment of the CWD will impose a demand in excess of the capacity of the existing main, it may be necessary to replace the existing main with one

of appropriate size. The full cost thereof, the applicant shall pay including any tests, studies, investigations and inspections required for design and construction.

### ***Major Development Project Reviews***

When the CWD must reasonably secure professional engineering and legal reviews for major development projects, the applicant shall pay for such engineering or reviews up to a reasonable limit.

## **SECTION 9. HYDRANTS**

### **Ownership**

Unless the Managing Director expressly determines otherwise with respect to specific locations, all hydrants located in public ways, city-owned easements or private ways open to public travel shall be owned and maintained by the CWD.

### **Installation**

All hydrants installed by outside contractors shall meet CWD specifications and comply with CWD details for installation. The CWD and the CFD must review plans before a permit will be issued. All hydrants shall be located on City property. Any hydrant installed on property not owned by the City shall be privately owned and maintained. All newly installed hydrants shall be flow tested by the contractor installing the hydrant and shall be color-coded accordingly:

BLUE/SILVER	Flows 1500 gpm or greater
GREEN/SILVER	Flows 950 gpm or greater
ORANGE/SILVER	Flows 650 gpm or greater
RED/SILVER	Flows 450 gpm or greater
BLACK/SILVER	Flows less than 450 gpm

### **Hydrant Removal**

All requests for a City-owned hydrant to be removed must be accompanied with a written approval from the CFD and subject to CWD approval.

### **Location**

Hydrants shall be placed at locations designated by the CWD, with the previous approval of the CFD, to facilitate public fire protection. As a condition of new or extended water service, the CWD may require an owner to pay for the cost of hydrant installation, if the CWD determines that such new or extended water service creates additional fire protection requirements.

### **Relocation**

An owner may request approval to relocate a hydrant. The request shall include a plan of the relocation designed by a registered professional engineer. If the relocation and design is approved by the CWD, CFD, DPW and all abutters have been notified, the owner shall have the work performed at its expense by a contractor bonded and approved in accordance with Section 8 above.

### **Permits for Use of a Hydrant**

Any use of a fire hydrant by someone other than the CWD or the CFD requires an application for a permit (See **Appendix B**). Fees for hydrant rental are those set in the CWD fee structure (See **Appendix A**). Certain conditions may require the use of a backflow preventer.

### **Hydrant Flow Tests**

Hydrant flow tests shall be performed by the CWD from April 1<sup>st</sup> to November 1<sup>st</sup> at the requesting person's expense. Fees for hydrant flow tests are those set in the CWD's fee structure (**48 hour notice is required**).

## **SECTION 10. WATER-COOLED AIR CONDITIONING AND REFRIGERATION**

An air conditioning or refrigeration unit or units requiring more than 60 cubic feet of water per hour cannot be used without provision for water recycling. Larger systems shall include a device enabling the reuse of water supplied in the system and the reuse device shall be in operation whenever such system is in operation. Such shall be subject to the provisions of **Article V, Cross-Connections**.

## **SECTION 11. FOUNTAIN AND IRRIGATION SYSTEMS**

### ***General Requirements***

Free-flowing fountains discharging directly to drains or sewers are prohibited. All fountains shall be equipped with a shut-off mechanism, appropriate cross-connection control and backflow preventer. Drinking water fountains shall be equipped with an automatic shut-off mechanism. Outside decorative fountains shall be turned off from October 15<sup>th</sup> until March 31<sup>st</sup> of each year.

### ***Irrigation Systems***

All irrigation systems shall be equipped with an appropriate cross-connection control device and a meter at the Owner's expense. All outside installations must be protected from freezing and theft in an approved above-ground method (see detail).

### ***Restrictions on Fountain and Irrigation Systems***

During a Drought Watch, as identified or declared by the CWD, the Managing Director may require that non-recirculating, decorative fountains be turned off.

## **ARTICLE III WATER SERVICE**

### **SECTION 1. APPLICATION FOR WATER SERVICE**

#### ***Application Procedure***

In order to obtain approval to construct or change the size or location of a water service pipe connection to a public water main, the owner shall submit a Water Works Construction Permit (**Appendix B**). Water Works Construction Permit forms may be obtained at the CWD's offices. A completed Water Works Construction Permit includes verification by the applicant that the address listed is the correct address for the premises in question. A shall be supplemented by building site plans approved by the CWD and by such other permits, plans, specifications and information as the CWD may require. Approval of a Water Works Construction Permit shall be subject to the availability of capacity in the public water main as determined by the CWD.

#### ***Expense Borne by Owner***

All costs and expenses incident to submission of and to the design, construction, connection and inspection of a water service pipe shall be borne by the owner.

#### ***Existing Users***

In the absence of a signed General Service Application, the provision of water service by the CWD and its use by the owner shall nonetheless be subject to all provisions of these Procedures.



## **SECTION 2. RATES AND FEES**

### ***Water Rates***

All water will be sold as follows:

Residential Rate - Per cubic foot and a customer charge, billed quarterly

Non-Residential Rate - Per cubic foot

Minimum bill of \$7.50

## **SECTION 3. WATER SERVICE PIPES**

### ***Design and Construction Standards***

Water service pipes within a public way or a private way open to public travel shall be constructed in accordance with the CWD specifications. Water service pipes within private property shall be constructed in accordance with the latest version of the Massachusetts Plumbing Code and all CWD guidelines.

### ***Location of Water Service Pipe***

No water service pipe shall be laid in the same trench with any other public or private facilities, except a fire pipe, nor within ten feet of a sewer. The minimum bury shall be (5) feet unless approved by the CWD. Any connection of a water service pipe to a public main shall be made in a public way and run 90 degrees of the CWD main. (See Article 1 Sec. 2 line G)

### ***Limitations on Tapping Mains***

Where there is more than one public water main in a street, the CWD shall determine which main the owner may tap for a water service pipe connection. Water mains designated as transmission mains shall not be tapped for water service, except when approved by the CWD. All new taps shall be a minimum of one pipe size smaller than the main to be tapped. Otherwise, a solid sleeve three-way branch shall be used to connect to the new main.

### ***Separate Services***

In general, the CWD requires a single water service pipe and a master meter for multiple unit premises. Otherwise, a separate service line and meter shall be required for each premises of different address or ownership. The CWD's policy on domestic water services for condominiums is as follows: Before a CWD new water service construction permit can be issued the owner/developer must provide to the CWD's Engineering Division a Massachusetts P.E. stamped sketch (i.e., 8 ½" X 11" SK) showing the specific location and piping configuration details of the **single, appropriately sized master water meter** that will meter all condominium unit water usage. The CWD's requirements are that this location must have proper heating, year round, and provide adequate access to subject master meter for testing and servicing by the CWD's meter technicians. The CWD's policy does not allow individual condominium unit meters controlled by the CWD. The owner/developer has the option to sub-meter all individually owned condominium units downstream of CWD's master meter. This option is per the Massachusetts General Law, MGL Chapter 186-Section 22.

### ***Redundancy Water feed/three way valving***

For all new construction as a minimum involving Laboratories, Biotech buildings, Hospitals, Schools, and buildings with 50 units or more or any other facility where the water need is considered critical during emergency situations or for performance of routine maintenance the owners will be required to install redundant water services (feeds).

The City of Cambridge Water Department must approve all plans and reserves the right to require facilities, developments and other projects to use multiple water services (feeds).

In the event that water service redundancy is not obtainable through separate water sources in the street, a 3-way valve setup will be **required**.

### ***Combined Service***

All provisions within this Article for water service pipes shall also apply to existing combined services. New combined services shall not be installed, unless the CWD determines that a combined service is in the interest of efficiency.

### ***Installation of Water Service Pipe***

The owner or the owner's CWD approved contractor shall be responsible, at its expense, for installing the water service pipe and appurtenances and making connection to the public water main designated by the CWD and cutting and capping any water service pipe to be abandoned. The owner or owner's contractor shall: (1) arrange with at least 24 hours advance notice for an inspection by the CWD before backfilling the installed water service pipe and appurtenances; and (2) not backfilling the installation until after receipt of a written inspection certificate from the DPW.

## **SECTION 4. METERS AND METER TESTING**

### ***Furnishing of Meters and Meter Size***

In new installations, the CWD shall furnish at its expense meters up to and including 2-inch meters in size. New meter installations greater than 2 inches in size shall be furnished and maintained in good working order by the owner. The size of the meter required shall be determined by the owner and subject to the approval of the CWD. One meter shall be supplied for each service line tapped off of a City main.

### ***Ownership***

All meters once installed, become the property of the CWD.

### ***Installation of Meters***

All meters up to 2 inch in size shall be installed by the CWD at its expense. Prior to installation of the meter, the owner shall, at its expense, complete the plumbing so that the premises are ready for meter installation. All meters greater than 2 inches in size shall originally be installed by the owner at its expense and inspected by the CWD. Replacement of such meters will be CWD's approval. Meters 2 inches in size and larger shall be the turbine type and shall be provided with a 1-inch tap for meter testing by the CWD. **All meters larger than 2 inches shall be installed with a strainer.**

### ***Location of Meters***

All meters shall be installed within an owner's building in an ample and suitable space free from exposure to freezing, unless otherwise directed by the CWD. This space shall at all times be unobstructed and accessible to the CWD. The owner shall be responsible for any damages as a result of not adhering to this section. **(Pit meters are prohibited.)**

### ***Outside Meter-Reading Devices***

The CWD may install a device within or on the outside of a building in a conveniently accessible location to enable routine meter readings without internal access to the owner's building. **Required on all new installations.**

### ***Right to Enter Premises***

In accordance with the provisions of **Article VI** of these Procedures and Massachusetts General Laws, Chapter 165, Section 1, the CWD may enter premises to examine or remove meters, pipes, fittings; and work for supplying or regulating the supply of water and to ascertain the quantity of water consumed or supplied.

### ***Meter Testing***

All meters may be subjected to periodic tests by the CWD. An owner may request that their meter be tested by the CWD. An approved testing company at the owner's expense will perform all requests for meter tests.

### ***Meter Tampering***

No person shall bypass, tamper with, or prevent a meter from registering water consumption and such acts shall be subject to the penalties stated in Massachusetts General Laws, Chapter 165, Section 11 and to such other penalties as the CWD may adopt under **Article VI** of these Procedures.

### ***Master Meters***

The CWD, at its sole discretion, may require the master metering of more than one water service. In such cases, the owner of the premises served shall be responsible for payment of all water charges and the acceptance of all related notices. This includes but is not limited to, condominiums and townhouses.

### ***Meter Replacement or Repair***

The CWD maintains an annual meter installation and maintenance program. If plumbing work is necessary to make the premises meter-ready, the CWD will provide plumbing specifications to enable the owner to prepare the premises for meter installation.

## **SECTION 5. REPAIRS, MAINTENANCE AND THAWING**

### ***Repairs and Maintenance***

The water service pipe supplying a property shall at all times be kept by the owner in good repair, free of leaks and protected from frost and corrosion. In the case where the portion of the water service pipe is damaged by neglect or carelessness of the owner of the premises served, or any plumber, contractor, occupant or other person acting on behalf of the owner of the premises, all necessary repairs shall be made at the owner's expense.

### ***Leak Up To Owner***

If the CWD determines that there is a leak on the property side water service, the CWD shall so notify the owner and the owner shall be responsible for having the leak repaired. A leaking water service pipe may be shut off by the CWD, in accordance with the provisions of **Article III, Section 5**.

### ***Thawing***

The owner is responsible and shall bear the expense for thawing a frozen water service pipe.

## **SECTION 6. SHUT-OFF, TERMINATION, ABANDONMENT AND LET-ON**

### ***Shut-off***

The CWD may shut off water service without notice in order to perform emergency work on a public water main or a water service pipe or pursuant to Article V, Section 3 hereof. At the owner's request, the CWD may shut off water service to a premises in order for the owner to make repairs or for temporary vacancy.

### ***Termination by the CWD***

An owner may discontinue the owner's water service to a vacant building by notifying the CWD in writing at least three working days in advance of the date on which water service is to be discontinued.

### ***Abandonment***

When water service has been discontinued for a period of one year or more and no commitment has been provided by the owner as to possible future use, the CWD may, at its sole discretion, consider the water service to be abandoned and may disconnect the water service pipe(s) from the public water main at the owner's expense. The CWD shall send to the owner (as reflected on CWD records) written notice by certified mail, return receipt requested that such disconnection would occur within one week after the date of the notice.

### ***Let-On***

Only the CWD shall let-on water service. After inspection of a newly installed water service pipe and upon request by an owner, the CWD shall let-on water service only if someone is present at the site. If an owner requests the CWD to shut off water service, then the CWD will let-on the water service only after a subsequent request by the owner. The CWD may let-on water service without notice after performing work on a public water main or a water service pipe.

### ***Let-On After Termination***

When water service to any premises has been terminated for any reason, it will be let-on by the CWD only after the conditions, circumstances or practices that caused the water service termination are corrected.

### ***Let-On After Abandonment or Discontinuance***

If a water service pipe has been abandoned for one year or longer or if water service has been discontinued for one year or longer, the service will be let-on only after the owner submits a General Service Application.

### ***Let-On Of Lead Service Pipe Prohibited***

If a lead water service pipe is discontinued or abandoned, the water service shall not be let-on until a new Water Works Construction permit is submitted by the owner and the lead water service pipe has been replaced with a new pipe of approved material.

## **ARTICLE IV PRIVATE FIRE PROTECTION**

### **SECTION 1. APPLICATION FOR A FIRE SERVICE LINE**

#### ***Application Procedures***

In order to obtain approval to construct or change the size or location of a fire line connecting to a public water main, the owner shall submit a General Service Application. The application shall be supplemented by building site plans approved by ISD. Approval of the application shall be subject to the availability of capacity in the public water main as determined by the CWD.

#### ***Expenses Borne by Owner***

All costs and expenses pertaining to the completion of a General Service Application, the design, construction, connection and inspection of a fire pipe shall be borne by the owner.

#### ***Existing Users***

In the absence of a signed General Service Application, the provision of water service by the CWD and its use by the owner shall nonetheless be deemed subject to all provisions of these Procedures.

### **SECTION 2. FIRE LINES**

#### ***Design and Construction Standards***

Fire protection lines shall be constructed in accordance with CWD specifications and latest versions of the Massachusetts Plumbing Code, City Fire Prevention Code and National Fire code.

#### ***Location of Fire Pipe***

No fire service line shall be laid in the same trench with any other public or private facilities, except a water service pipe or within ten feet of a sewer. Any connection of a fire service line to a public main shall be made in a public way at 90 degrees of the CWD water main.

#### ***Limitations of Tapping Mains***

Water mains designated as transmission mains shall not be tapped for a fire pipe, except when approved by the CWD. All new taps shall be a minimum of one pipe size smaller than the main to be tapped; otherwise, a solid sleeve three-way branch shall be used to connect to the new main.

#### ***Limitations on Water Use***

Where there is more than one public water main in a street, the CWD shall determine which main the owner may tap for a fire service line connection. Water supplied through a fire line shall be for fire protection only, except for annual fire pump tests. A fire line shall not be connected with a water Domestic service line.

#### ***Installation of Fire Service Line***

The owner or the owner's contractor shall be responsible, at its expense, for installing the fire service line and appurtenances including a street side valve, tapping and making connection to the public water main designated by the CWD; and cutting and capping any water service line to be abandoned. The owner or owner's contractor shall: 1) arrange with at least 24-hour advance notice for an inspection by the CWD before backfilling the installed fire line and appurtenances; and 2) not backfill the installation until after receipt of a written inspection certificate from the DPW. The owner shall provide access to the property for the inspection by the CWD and DPW.

### **SECTION 3. REPAIRS, MAINTENANCE AND THAWING**

#### ***Repairs and Maintenance***

The fire pipe shall at all times be kept by the owner of the premises and at its expense in good repair, free of leaks and protected from frost and corrosion.

#### ***Repair Of Leaks***

The owner shall be responsible for having a leak in a fire line repaired at the owner's expense. Such a leaking fire line shall be shut off by the CWD in accordance with the provisions of **Section 6 of this Article**.

#### ***Thawing***

The owner is responsible, at its expense, for thawing a frozen fire pipe.

### **SECTION 4. SHUT-OFF, TERMINATION, ABANDONMENT AND LET-ON**

#### ***Shut-Off***

No shut-off of a fire line shall occur except in accordance with Massachusetts General Laws Chapter 148, Section 27A and with the City of Cambridge Fire Prevention Code. After compliance therewith, the CWD may shut of a fire pipe without notice in order to prevent the loss of water, to prevent or stop damage to property or to perform work on a public water main. At the owner's request, the CWD may shut-off water service to a premises in order for the owner to make repairs, providing that the CFD has been notified.

#### ***Discontinuance by the Owner***

No discontinuance of a fire line shall occur except in accordance with Massachusetts General Laws, Chapter 148, and Section 27A and with the City of Cambridge Fire Prevention Code. After compliance therewith, an owner may discontinue the owner's fire service to specific premises by notifying the CWD in writing at least three working days before the date on which the fire line is to be discontinued.

#### ***Abandonment***

No abandonment of a fire pipe shall occur except in accordance with Massachusetts General Laws, Chapter 148, and Section 27A and with the City of Cambridge Fire Prevention Code. After compliance therewith, if a fire pipe has been discontinued for a period of one year or more and no commitment has been provided by the owner as to the possible future use, the CWD may, at its sole discretion, consider the fire pipe to be abandoned and may disconnect the fire pipe(s) from the public water main at the owner's expense. The CWD shall mail to both the owner (as reflected on CWD records), a written notice that such disconnection shall occur unless the owner makes other arrangements with the CWD within one week after the date of the notice.

#### ***Let-On***

Only the CWD shall let-on a fire line. After inspection of a newly installed fire line and upon written request by the owner, the CWD shall let-on water service only if someone is present at the site. If an owner requests the CWD to shut-off water service, then the CWD will let-on the water service only

upon request by the owner. The CWD may let-on water service without notice to the owner after performing work on a public water main.

#### ***Let-On After Termination***

When water service to the fire pipe of any premises has been terminated for any reason, it will be let-on by the CWD only after the conditions, circumstances or practices that caused the water service termination are corrected.

***Let-On After Abandonment or Discontinuance***

If a fire pipe has been abandoned for one year or longer, or if water service has been discontinued for one year or longer, the service will be let-on only after the owner submits a General Service Application.

**ARTICLE V CROSS-CONNECTIONS**

**SECTION 1. BACKFLOW PREVENTORS**

***Backflow Preventers Required***

No person shall maintain a cross-connection without an approved backflow preventer. Backflow preventer shall comply with the provisions of the Massachusetts Department of Environmental Protection (DEP) Drinking Water Regulation 310 CMR Section 22: Cross-Connections.

***Plan Approval and Initial Inspection***

The CWD, as the designee of the DEP, shall approve all plans for the installation of backflow preventors and, after installation, shall perform the initial inspection and test of the backflow preventors

***Installation of Backflow Preventers***

The owner at its expense shall install Backflow preventors and the installation shall be approved by the CWD.

***Subsequent Testing***

After installation, the CWD shall semi-annually test and inspect all backflow preventors, at the owner's expense, to insure continuous satisfactory operation.

**SECTION 2. CROSS-CONNECTION INSPECTION**

***Right to Enter***

The CWD may enter premises served by a public or private water main at all reasonable times for the purpose of conducting routine, periodic surveys and investigations of cross-connections and potential cross-connections within the premises. On request by the CWD, the owner shall furnish information on water use practices within the owner's premises. Premises having or suspected of having cross-connections in violation of these Procedures may be inspected regularly for backflow hazards.

***Notification***

Notwithstanding any other provision of these Procedures, investigations and inspections for the purpose of locating possible cross-connections in violation of these Procedures may be performed by the CWD without prior notice to the owner.

### **SECTION 3. CROSS-CONNECTION ELIMINATION**

#### ***Prevention of Cross-Connections***

The backflow of non-potable water, other liquids or foreign materials into public water mains is prohibited. Public private water mains shall be protected against cross-connection and backflow from any plumbing fixture or other equipment or appliance capable of affecting the quality of the water supply. All backflow prevention devices shall be approved by the DEP.

#### ***Shut-Off Of Water Service***

The CWD shall have the right to shut-off water service without prior notice to eliminate a cross-connection or backflow condition where contaminants are actually in the process of or suspected of entering the potable water supply, or where there is, in the CWD's judgment, the reasonable possibility that such contamination will occur if the water service is not shut-off. Under such conditions, the water service shall remain shut-off until the cross-connection or backflow connection is eliminated, or the condition is remedied, at the owner's expense and the remedial work has been approved by the CWD.

### **SECTION 4. OWNER'S LIABILITY**

**The owner shall be liable to the CWD and shall reimburse the CWD for all penalties, fines and monetary judgments levied against or imposed upon the CWD as a result of the owner's violation of any provision of this Article.**

## **ARTICLE VI ENFORCEMENT**

### **SECTION 1. INSPECTION**

#### ***Right of Access***

Duly authorized representatives of the CWD may inspect the property or the facilities of any owners or users (including facilities under construction) to ascertain compliance with Procedures. Owners or occupants of premises where water service pipes or fire lines are located shall allow properly identified CWD representative ready access, at all reasonable times during normal business hours and at such other times as the CWD reasonably suspects that a violation of these Procedures may be occurring, to such parts of the premises as would enable CWD personnel to inspect, observe, measure sample and test:

- A. Water Use;
- B. Buildings;
- C. Water quality;
- D. Meters;
- E. Water service pipes;
- F. Fire pipes;
- G. Cross-connections and backflow preventors; and
- H. Other facilities that the CWD reasonably believes may be contributing to a violation of these Procedures.



### ***Right of Entry***

Upon proper identification and at reasonable times during normal business hours and at such other times as the CWD reasonably suspects that a violation of these Procedures may be occurring, duly authorized representatives of the CWD shall be permitted to enter all private property through which the CWD holds an easement for the purpose of inspection, observation, measurement, sampling, testing,

maintenance, repair or reconstruction of any portion of a public water main lying within said easement. All entry and subsequent work, if any, shall be done in full accordance with the terms of said easement.

### ***Security Clearance***

Where a user has security measures in force that would require clearance before entry to the premises, the user shall make necessary arrangements to permit CWD personnel to enter without undue delay for the purpose of carrying out their specific responsibilities.

### ***Consequences of Denial of Entry or Access***

Where an owner or user, after having received reasonable notice from the CWD, refuses to permit properly identified CWD personnel to enter or have access to premises or facilities in accordance with the terms of this section, the CWD may forthwith give written notice of its intent to terminate water service to such user or owner.

## **SECTION 2. ENFORCEMENT**

### ***Alternative Actions***

Where the CWD determines that 1) a violation of these Procedures; or 2) any damage to the public water mains is threatened or has occurred, any one or more the following may be taken:

- A. The CWD may shut-off water services as authorized elsewhere in these Procedures.
- B. The CWD may issue an order to cease and desist any such violation and may direct the violator(s) as follows:
  - 1. To comply with these Procedures and with the cease and desist order either forthwith or in accordance with a time schedule set forth by the CWD; or
  - 2. To take appropriate remedial preventive action in the event of a threatened violation.
- C. The CWD may require the user in question to submit a detailed schematic plan and time schedule or require such other actions within such times as the CWD deems appropriate.
- D. The CWD may take direct enforcement action by filing suit in any court of competent jurisdiction.
- E. The CWD may issue citations pursuant to M.G.L. Ch. 40, ss 21D, non-criminal disposition, to the extent allowed by Ordinance.

### **SECTION 3. LIABILITY**

#### ***No Direct Or Consequential Damage As A Result Of A Let-On Or Shut-Off***

The CWD shall not be responsible for any damage resulting from the shut-off or subsequent let-on of water, including but not limited to busting or collapse of water heaters or boilers supplied by direct pressure; damage by debris in dirty water; the breaking of any pipes, fixtures or control valves; stoppage or interruption of water supply. The CWD shall also have no responsibility for any consequential damages (including, but not limited to, food or housing costs) incurred by an owner, customer or user as a result of the shut-off or subsequent let-on of water.

#### ***Damage as a Result Of Water Use or Leak***

No user shall utilize any apparatus or device or use water in such a way that could or does adversely affect a public water main, appurtenance or water service pipe. The user shall be liable for any damage to public water mains, appurtenances or water service pipes or property resulting from a violation of these Procedures.

#### ***Damage During Owner Repairs and Installations***

The owner shall indemnify the CWD from, and shall reimburse the CWD for any loss or damage directly or indirectly caused to the CWD's water facilities by the installation of any privately owned portion of water service pipe, fire line or other plumbing.

#### ***Indemnification***

An owner or user shall indemnify and hold harmless the CWD for any damages or civil liabilities the CWD may sustain or be required to pay in consequence of an injury or property damage resulting from that owner's or user's violation of these Procedures.

#### ***Governmental Function***

In acting under these Procedures, the CWD shall be deemed to be performing a governmental function for the benefit of the general public. The CWD shall not be liable for any loss or damage as a result of the performance of such governmental function.

#### ***Monetary Liability***

Any person who violates any provision of these Procedures shall, upon issuance CWD order to that effect, forfeit and pay to the City Treasurer the penalty established by applicable Massachusetts General Laws or by these Procedures for each such violation. For purposes of this section, each day that a violation continues shall be deemed to be a separate violation.

#### ***Reimbursement for Costs to CWD***

Failure to comply with any portion of these Procedures, or with any permit or order issued there under, shall be sufficient cause for the CWD to levy on and collect from each violator any additional cost for any expense, loss or damage incurred by the CWD as a result of such violation.

## **SECTION 4. PENALTIES**

### ***Amounts***

Violations of these Procedures shall be subject to civil monetary penalties established 1) by applicable Massachusetts law; 2) by applicable rules and regulations of the DEP; and 3) by such penalty schedules as may from time to time be adopted by the CWD and appended to these Procedures.

### ***Continuing Violations***

For purposes of the computation of penalties, each day of a continuing violation of these Procedures shall be deemed to be a separate violation.

### ***No Court Limitation***

If the City elects to file an enforcement action in a court of competent jurisdiction, the damages then recoverable by the City shall not be limited to amounts recoverable under these Procedures.

## **ARTICLE VII APPELLATE PROCEDURES**

### **SECTION 1. IMMEDIATE RIGHT TO A HEARING FOR SHUT-OFFS OR TERMINATIONS**

The owner shall receive notice to a hearing within 24 hours of a service shut-off or termination. The CWD has the option to reconnect service temporarily, without waiving the infraction that caused the shut-off or termination, until a formal appeal outline in **Section 2** is conducted.

### **SECTION 2. APPEALS FROM CWD ACTIONS INCLUDING SHUT-OFF OR TERMINATION**

#### **A. At the Managing Director's level:**

##### ***Informal Conference***

Whenever the CWD, acting under these Procedures, denies an application, requires an owner or user to build or install any particular facility or device, issues a cease and desist order, a compliance order or an implementation schedule or assess penalties or other charges for non-compliance, the CWD shall promptly so inform the owner or user to whom such action is addressed. Such notice shall be sent by first-class mail and shall inform the addressee of his right to submit, within 14 days after the date of such notice, a written request for reconsideration of the CWD's action. A request for reconsideration shall be addressed to the Managing Director at the CWD's Administrative Office and shall set forth in detail the facts supporting it. Upon receiving such a timely request for reconsideration, the Managing Director or his/her designee shall schedule an informal conference with the owner or user making the request. Written notice of the conference date, time and place shall be mailed to the owner or user at least ten days (unless waived by the owner) before the date of the conference, which shall be held no later than 21 days (unless waived by the owner) after receipt of the request. The Managing Director or his/her designee shall rule in writing on the request for reconsideration within 14 days (unless waived by the owner) after completion of the conference and shall promptly notify the owner or user of his/her decision.

##### ***Hearings by the Managing Director***

A copy of the decision on the request for reconsideration shall be mailed to the owner or user who submitted the request. The decision shall be accompanied by a notice that the owner or user has the right to request a hearing before the CWD or its designated representative. The written notice shall inform the addressee that a hearing on the CWD's action must be requested within 30 days after the date of the written notice by a writing addressed to the Managing Director at the CWD's Administration Office. Within 15 days (unless waived by the owner) after receiving a timely written request for a hearing, the CWD shall schedule a hearing and shall mail to the owner or user which requested the hearing a written notice specifying the date, time, place and subject matter of the hearing. The notice shall also state that the entity requesting a hearing has the right to be represented by legal counsel and to present evidence (in the form of both documents and testimony) at the hearing.

##### ***Conduct of Hearings by the Managing Director***

Any hearing scheduled under this section shall be held not sooner than 15 days nor later than 30 days (unless waived by the owner) after the date of the hearing notice. The rules of evidence observed by courts need not be adhered to. The proceedings may be tape-recorded and the recording shall be kept in the CWD's custody. Any person who desires a transcript of the hearing may obtain one from the CWD, upon payment to the CWD of the transcription charge reasonably incurred by the CWD.

##### ***Hearing Record and Decision by the Managing Director***

At any hearing scheduled under **Section 3**, above, the documents and other evidence offered shall constitute the hearing record. The hearing decision shall be based solely on the hearing record and shall be made within 30 days (unless waived by the owner) after the conclusion of the hearing. The decision shall be embodied in writing which summarizes the matters considered and the reasons for the determination made on each such

matter. The written decision shall be signed and dated by the Managing Director or his/her designated representative and shall be mailed to the owner or user which had requested the hearing.

**B. Further review by the City Manager:**

Any owner or user aggrieved by the decision of the Director may petition the City Manager to review the written decision and hearing record. A grievred owner or user must cause to be delivered to the City Manager on or before the 14<sup>th</sup> calendar day after the date of the Director's decision a written petition for review of the decision and record. If the aggrieved owner or user so causes the petition to be delivered, then the City Manager shall review the hearing record and the Director's decision; and shall within 30 calendar days (unless waived by the owner) following the receipt of the petition for review issue in writing either a confirmation or modification of the Director's decision, addressed to the petitioning owner or user and with copies to the Director.

**ARTICLE VIII ADOPTION**

**SECTION 1. SUPERCEDES PRIOR PROCEDURES**

These procedures take precedence over any inconsistent or conflicting CWD Procedures.

**SECTION 2. SEVERABILITY**

The invalidity of any selection, clause, sentence or provision of these Procedures shall not affect the validity of any other part that can be given effect without such invalid part or parts.

**SECTION 3. RIGHT TO AMEND**

The City Manager reserves the right to amend these Procedures in any manner, at any time and to establish any more stringent requirements as is deemed necessary or appropriate.

# **APPENDIX A**





# **SPECIAL SERVICE FEES**

## Cambridge Water Department Fee Schedule

1	<b>Permits Required</b>	NOTES
a.	Water Permit Fee (includes one site inspection. Additional inspections are <b><u>\$125.00 per site visit</u></b> )	1
	1 inch	\$125.00
	1½ inch	\$150.00
	2 inch	\$200.00
	4 inch	\$250.00
	6 inch	\$500.00
	8 inch	\$750.00
	10 inch	\$1,000.00
	12 inch	\$1,000.00
b.	Fire Pump Test Standard	2 \$225.00
c.	Fire Pump Test Rooftop	\$225.00
d.	Fire Pump Test Initial Startup	\$300.00
e.	Fire Pump Test Standard and Rooftop	\$350.00
f.	Demolition	3 \$200.00
g.	Back Flow	4 \$25.00
<b>2</b>	<b>Fire Hydrant Temporary Connection</b> (Up to and including 30 calendar days of use)	<b>5</b> \$100.00
a.	¾ inch & 1 inch	\$50.00/day + \$2000.00 deposit
b.	1 ½ inch & 2 inch (More than 30days of use)	\$100.00/day + \$2000.00 deposit
<b>3</b>	<b>Water Service Taps</b>	<b>6</b>
a.	1 inch	\$350.00
b.	1 ½ inch	\$400.00
c.	2 inch	\$450.00
<b>4</b>	<b>New Water Service Installation/ or Change in Size/ Plus Tap</b>	<b>7</b>
a.	1 inch	\$110.00/ft.
b.	1 ½ inch	\$125.00/ft.
c.	2 inch	\$130.00/ft.
d.	Minimum Charge	\$1,000.00
<b>5</b>	<b>Inspections</b>	
a.	First	(In permit fee)
b.	Back flow Device Test (each)	\$100.00
c.	Back flow Re-test (each)	\$100.00
<b>6</b>	<b>Fire/Hydrant Flow Test</b>	<b>8</b>
a.	Each Report	\$175.00
b.	Reverse Flow	\$225.00
<b>7</b>	<b>Fire Line Installation</b>	9 (same as 1.)
<b>8</b>	<b>Construction Water</b>	\$5000.00 Deposit + \$100.00 Backflow Test
<b>9</b>	<b>Final Bill / Reading</b>	<b>10</b> \$25.00
<b>10</b>	<b>Meter / MTU Replacements</b>	<b>11</b>
a.	Meter Transmitter Unit (MTU) installed	\$300.00
b.	5/8 inch	\$100.00

c.	¾ inch		\$120.00
d.	1 inch		\$190.00
e.	1.5 inch		\$300.00
f.	2 inch		\$400.00
<b>11</b>	<b>Water Service/Disconnect</b> (i.e., “clip and cut” at water main)	<b>12</b>	
a.	¾ inch		\$1,500.00
b.	1 inch		\$1,500.00
c.	1 ½ inch		\$1,500.00
d.	2 inch		\$1,500.00
	Emergency Response	<b>13</b>	Cost plus 30% admin fee
<b>12</b>	<b>Bacterial Testing</b>	<b>14</b>	<b>\$100.00</b>
<b>13</b>	<b>Fire Service Fee</b> (annual user fee)	<b>15</b>	<b>\$500.00</b>
<b>14</b>	<b>Fines</b>	<b>16</b>	
a.	Illegal use of hydrants		\$300.00/occurrence
b.	Illegal water service connection		\$300.00/occurrence
c.	Failure to obtain permits		\$300.00/occurrence
d.	Damaged MTU		
e.	Meter tampering		

**\*NOTES**

1. Fees for the CWD Permit include (1) one site inspection. A separate fee of \$125.00 per site visit is required, regardless of service size; if additional site work inspections are deemed necessary (additional site inspections may be arranged at time of permit issuance).
2. Other City permits may be required. For testing that takes place on Sundays, holidays and outside regularly scheduled work hours, the fee will be increased from \$225.00 to \$350.00 to cover overtime rate of pay for CWD personnel.
3. This fee is only for the CWD authorized signature on the ISD issued Demolition Permit. Demolition permits will not be endorsed unless the service is “clipped” at the water main (not the curb stop on the sidewalk) and/or a \$1000.00 deposit is received.
4. Fee is for the issuance of the CWD Back Flow Preventer Permit for a new back flow device. Fee includes initial inspection/test by a CWD inspector.
5. This may require a back flow inspection.
6. CWD is responsible for obtaining “street opening permit”.
7. This fee is for the tap work at the water main. It **DOES NOT** include the cost for excavation/paving. The “owner” is responsible for obtaining the CDPW issued “Street Opening Permit”.
8. This may require a back flow inspection. All hydrant flow tests to be performed from April 15<sup>th</sup> to November 1<sup>st</sup>. Dates between November 1<sup>st</sup> and April 14<sup>th</sup> are weather dependent and at the CWD’s discretion.
9. Fire service line installations are by the “owner” and require a CWD Permit issued with the fee schedule/size as in NOTE 1, above.

10. This is an administrative fee to cover the cost to verify the final meter reading. This cost will be included on the final water bill for the metered account.
11. Each **residential** customer account will be furnished with (1) one meter and (1) one outside remote reader (MTU) receptacle at no additional cost for a new domestic service line (ref. NOTE 1. above). If a meter malfunction occurs as a result of negligence on the part of the owner, the owner shall bear the cost for a new meter. The CWD requires one service connection = one account = one meter. **Multiple meter lines are the owner's responsibility.**
12. This fee covers the cost for CWD to perform the work for domestic and or fire services up to and including a 2" diameter service feed. Services must be "clipped" at the water main (not the curb stop on the sidewalk). Service lines larger than 2" diameter must have their attaching "Tee's" cut out of the water main and a full sized "spool piece" installed in place of the "Tee". This will require CWD shutting down the water main at a mutually convenient time that must be pre-arranged with the CWD Distribution Division. A \$1000.00 deposit is required at the time of CWD Permit issuance and inspection fee(s) are also required (per NOTE 1, above).
13. This cost/fee is for work performed during regular scheduled work hours. Any inspections required outside of regularly scheduled hours will include the incremental cost associated with overtime pay of CWD personnel.
14. This fee covers the cost for a CWD lab technician to take (1) one sample of water from the work location for bacteria analysis. Additional sampling will generate a new equivalent fee.
15. This is an annual fee to have a fire service line connected to the Cambridge water system. **It is not** part of or included in any other CWD Permit fee.
16. The maximum fine by ordinance is \$300.00 per occurrence.

Please refer to CWD Water Service Installation and Maintenance Regulations as adopted by the Cambridge Water Board of September 8, 1998.

### ***Water Service Fee***

The Water Service Fee covers the actual cost of installing the necessary piping from the Cambridge water distribution system to the applicant's property line. It is the responsibility of the applicant or his contractor to install the water service line to his structure according to CWD specifications (permit required). The applicant or his representative must inform the CWD twenty-four (24) hours prior to beginning installation procedures. A representative of the CWD must approve the installation prior to back-filling and final connection.

All materials used must meet standards and be approved by the CWD for water work and the Department of Public Works for all other materials.

All service lines and meter locations are at the discretion of the CWD.

## **APPENDIX B**

### **WATER WORKS CONSTRUCTION PERMITS/ APPLICATION FOR RELEASE AGREEMENT**

**CITY OF CAMBRIDGE  
MASSACHUSETTS**

**TELEPHONE: 617-349-4770; FAX: 617-349-4796; TTY/TDD: 617-492-0235**

**“PERMIT APPLICATION FOR WATER WORKS CONSTRUCTION”  
(please print or type, complete entire form)**

DATE: \_\_\_\_\_ PERMIT # \_\_\_\_\_

**TO THE CAMBRIDGE WATER DEPARTMENT:**

Pursuant to the requirements of City Ordinance “Chapter 13.08” M.G.L. Chapter 40, Sections 39E and 39G; in accordance with “N.F.P.A. 25”, “248 CMR 2:00”, “310CMR 22”, CWD Construction and Operating Procedures, and any other regulations and standards incorporated by reference herein, the undersigned hereby acknowledges the receipt of the CWD’s;

- A** Conditions of Approval
- B** Fire Hydrant Rental, Pump Test and Flow Test Agreement
- C** Requirements for Backflow Preventor Installation
- D** Multiple Inspection Form (large projects)

and requests permission to construct, test, improve or install the apparatuses described below at the following location:

Address: \_\_\_\_\_ C.W.D. Grid Map \_\_\_\_\_  
\_\_\_\_\_ Permit Completed \_\_\_\_\_

**Part I: Water Works Improvements- provide brief description & circle general waterworks category that best describes the nature of work.**

- 1. Meter/OSR \_\_\_\_\_ Account # \_\_\_\_\_
- 2. Water Service \_\_\_\_\_
- 3. Water main \_\_\_\_\_
- 4. Back flow Prevention \_\_\_\_\_
- 5. Hydrant \_\_\_\_\_
- 6. Fire Pump Test \_\_\_\_\_

A scale drawing of the property location, showing the plot plan of the building(s), limits of the City right-of-way and the location of the proposed water works improvements must be included as part of the submittal.

**Part II: Connection Information & Customer Usage Data - Please Circle**

Main: 4 - 6 - 8 - 10 - 12 - 16 - 20 - 24 - 30 inches    Service: 1 - 1 1/2 - 2 - 4 - 6 - 8 inches  
Acct.: Commercial/Industrial/Institutional/Residential    Material: DICL / Type KCopper

**Part III: Owner and Contractor Information**

Owner Signature: \_\_\_\_\_ Contractor Signature: \_\_\_\_\_  
Name: \_\_\_\_\_ Name: \_\_\_\_\_  
Bus. Tele.: \_\_\_\_\_ Emerg. Tele.: \_\_\_\_\_ Bus. Tele.: \_\_\_\_\_ Emerg. Tele.: \_\_\_\_\_  
Address: \_\_\_\_\_ Address: \_\_\_\_\_

Contractor/Testor or  
Drain Layer Contractor Signature: \_\_\_\_\_ Date: \_\_\_\_\_  
Name: \_\_\_\_\_ Bus. Tele.: \_\_\_\_\_ Emerg. Tele.: \_\_\_\_\_  
Address: \_\_\_\_\_

**Part IV: Requirements and Sign Off (Circle all applicable: a, b, c, d, e, f, g,)**

- a. Dig Safe No.: \_\_\_\_\_  
Mark-out by CWD (Provide 24-hour notice to CWD): \_\_\_\_\_ Date \_\_\_\_\_
- b. Inspection by CWD (Provide 24-hour Notice to CWD): \_\_\_\_\_ Date \_\_\_\_\_
- c. Pressure/Pump Test (witnessed by/certification): \_\_\_\_\_ Date \_\_\_\_\_
- d. Disaffection (witnessed by/certification): \_\_\_\_\_ Date \_\_\_\_\_
- e. Public Works Department (Notification) \_\_\_\_\_ Date \_\_\_\_\_
- f. Cambridge Emergency Communications \_\_\_\_\_ Date \_\_\_\_\_
- g. Plumbing Permit, Inspectional Services Dept. \_\_\_\_\_ Date \_\_\_\_\_

**Part IV: Permit Approval**

Estimated Cost of Construction: \_\_\_\_\_ Refundable Retainer (10% of Construction Cost  
W/ \$150 Minimum)  
Estimated amount of water to be used: \_\_\_\_\_ hundred cubic feet  
Fee: \_\_\_\_\_ Check No.: \_\_\_\_\_ Deposit: \_\_\_\_\_ Check No.: \_\_\_\_\_  
Approved (Cambridge Water Department) \_\_\_\_\_ Date: \_\_\_\_\_  
Print Name: \_\_\_\_\_

This Permit is not effective until all approvals have been granted by the CWD.  
(No Water taps allowed on Fridays)

Start Date: \_\_\_\_\_ Expiration Date: \_\_\_\_\_

## A CONDITIONS OF APPROVAL

1. All abandoned (e.g. temporary, domestic, fire, irrigation, non-active, etc.) water lines must be cut and capped, at the main, with restrained joints or clipped and then inspected by the Water Department. Trench and surface condition must be inspected by the DPW.
2. All materials used are to meet AWWA Standards as applicable for water work. All other materials must meet specifications of DPW.
3. Ductile iron pipe is to be Class 52 or greater with 1/8-inch cement lining. Copper tubing shall be type K only.
4. Multiple taps must be a minimum of 3 ft. apart and 3 ft. from any joint or bell on the main being tapped.
5. When work is completed, as-built drawings **MUST** be submitted to the CWD within 60 days in triplicate prior to water turn-on. (Preferably in electronic format such as Auto CAD.)
6. The CWD must be notified 24 hours before water work is to start.
7. All shut-offs/turn-ons to be performed by CWD personnel. To arrange for this service call 617-349-4787.
8. All water work must be inspected prior to trench backfill. Please call to make arrangements 24 hours in advance for inspections.
9. All companies performing water construction must be bonded with DPW.
10. After the CWD permit is approved a street opening permit must be obtained from DPW.
11. If service is to be used for construction purposes, back flow devices may be required. For more information on back flow prevention please contact our Cross Connection Department.
12. Fire Department approval is required for fire line installation.
13. A certified check made payable to the City of Cambridge in the amount of 10% of the contract cost or \$1,000.00, whichever is lesser, shall be held on deposit by the CWD until satisfactory completion of the water construction. (No deposit required for private property.)



- 14. A 72-hour notice is required by the CWD to mark out the water utilities before construction can begin.
- 15. A Dig Safe number must be obtained before construction can begin.
- 16. All new water mains must be pressure tested and chlorinated before activation in the distribution system. A 24-hour notice is required by the CWD for pressure test and sampling after chlorination. Any questions, contact our Laboratory Supervisor to arrange sample collection.

Permit Number: \_\_\_\_\_

Name of Company: \_\_\_\_\_

Name of Representative: \_\_\_\_\_

(Print)

Signature of Representative: \_\_\_\_\_

# B

**HYDRANT RENTAL**  
**617-349-4778**

**FIRE PUMP TEST**  
**617-349-4778**

**FLOW TEST**  
**617-349-4787**

Tests can only be scheduled between April 1<sup>st</sup> - November 1<sup>st</sup> (weather permitting).

## **STANDARD PROCEDURE FOR THE OPERATION OF FIRE HYDRANTS**

1. Hydrants shall be operated with a five-sided adjustable hydrant wrench only.
2. When operating a hydrant, open it fully so that the drain ports will be fully closed. If the drain is partially open, water seeping through it could saturate the drainage field and result in the hydrant boot blowing off the 6-inch branch line.
3. Hose connections on the 2-1/2-inch nozzles can be isolated with gate valves and a backflow preventer. Quick-closure butterfly valves are not permitted because of the associated water hammer problems.
4. The renter is solely responsible for all damages to the fire hydrant, water distribution system and adjacent private properties (Cambridge Municipal Code 13.08.080).
5. A deposit of One Thousand Dollars (\$1000.00) is required.

## **RULES FOR FIRE PUMP TEST**

1. A seventy-two (72) hour notice is required for scheduling.
2. At no time during the test is the upstream pressure to go below 20 p.s.i.; if so the test shall be terminated.
3. Systems that are deemed inoperative or do not meet the required specifications are to be reported to the CFD immediately.
4. The permit applicant shall obtain a "Discharge Permit" and an "Obstruction Permit", if obstructing the city right of way with a hose, from DPW (617-349-4800) at 147 Hampshire Street. The applicant must submit a site plan showing the location of the catch basin which will receive the flow. Prior to the issuance of a permit DPW will approve the catch basin location.
5. It is the responsibility of the permit holder to retain the services of a police detail as required.

Permit Number: \_\_\_\_\_

Name of Company/Tester: \_\_\_\_\_

Name of Representative: \_\_\_\_\_

(Print)

Signature: \_\_\_\_\_

# C

## REQUIREMENTS FOR BACKFLOW PREVENTER INSTALLATION

Telephone: 617-349-4778

1. Complete one (1) form BRP WS 09 cross connection plan approval (design data form) for each device to be installed.
2. Submit a 8-1/2-inch by 11-inch sketch or schematic with each design data form.
3. Forms may be obtained from the secretary of the Inspectional Services Department or from the Cross Connection Department of the CWD.

Massachusetts Regulation Plumbing Code 248 CMR 2:14 (6) C (2), "No plumbing permit shall be issued for cross connection installation requiring reduced pressure zone backflow preventor or double check valve assemblies until the application for such permit is accompanied by a letter of approval from the Massachusetts Department of Environmental Protection (D.E.P.) or its designee. As the D.E.P. designee, the CWD will issue a letter of approval upon review and acceptance of the design data sheet.

**NOTE: Please call the Cross Connection office when the installation is complete and ready for testing.**

Permit Number: \_\_\_\_\_

Name of Installer/Contractor: \_\_\_\_\_

Signature of Installer/Contractor: \_\_\_\_\_

# D

## MULTIPLE INSPECTION FORM

Permit Number: \_\_\_\_\_

Name of Contractor: \_\_\_\_\_ Address: \_\_\_\_\_

Inspection of \_\_\_\_\_ CWD Inspectors: \_\_\_\_\_ Date: \_\_\_\_\_

Inspection of \_\_\_\_\_ CWD Inspectors: \_\_\_\_\_ Date: \_\_\_\_\_

Inspection of \_\_\_\_\_ CWD Inspectors: \_\_\_\_\_ Date: \_\_\_\_\_

Inspection of \_\_\_\_\_ CWD Inspectors: \_\_\_\_\_ Date: \_\_\_\_\_

Inspection of \_\_\_\_\_ CWD Inspectors: \_\_\_\_\_ Date: \_\_\_\_\_

Inspection of \_\_\_\_\_ CWD Inspectors: \_\_\_\_\_ Date: \_\_\_\_\_

Inspection of \_\_\_\_\_ CWD Inspectors: \_\_\_\_\_ Date: \_\_\_\_\_

Inspection of \_\_\_\_\_ CWD Inspectors: \_\_\_\_\_ Date: \_\_\_\_\_

Inspection of \_\_\_\_\_ CWD Inspectors: \_\_\_\_\_ Date: \_\_\_\_\_

Inspection of \_\_\_\_\_ CWD Inspectors: \_\_\_\_\_ Date: \_\_\_\_\_

**CITY OF CAMBRIDGE  
MASSACHUSETTS  
WATER DEPARTMENT  
250 FRESH POND PARKWAY  
CAMBRIDGE, MA 02138**

**Sam Corda**  
Managing Director

**TELEPHONE: 617-349-4770**  
**FAX: 617-349-4796**  
**TTY/TDD: 617-492-0235**

**HYDRANT FLOW TEST SUMMARY SHEET**

The CWD assumes no responsibility for design calculations.

Flow Test Requester: \_\_\_\_\_

Company Name: \_\_\_\_\_

Address: \_\_\_\_\_

City & State: \_\_\_\_\_

Pressure Hydrant Location: \_\_\_\_\_ I.D. # \_\_\_\_\_

Flow Hydrant Location: \_\_\_\_\_ I.D.# \_\_\_\_\_

The flow test requester is liable for all damages to the fire hydrant, water distribution system and adjacent private properties (Cambridge Municipal Code Section 13.08.080).

Signature: \_\_\_\_\_ Date: \_\_\_\_\_

**Flow Test Results**

Static Pressure: \_\_\_\_\_ Psi.  
Residual Pressure: \_\_\_\_\_ Psi.  
Flow Rate: \_\_\_\_\_ GPM

Performed by \_\_\_\_\_

Amount Paid: \_\_\_\_\_ Check #: \_\_\_\_\_

Approved: \_\_\_\_\_

**Cambridge Water Department  
City of Cambridge, Massachusetts**

**APPLICATION FOR A RELEASE AGREEMENT**

To the City of Cambridge, Massachusetts

The undersigned, being the \_\_\_\_\_  
(Owner, Owner's Agent)

of the Property located at \_\_\_\_\_ does  
(Number) (Street)

hereby request approval for a Release Agreement to transfer ownership of the \_\_\_\_\_  
extended, replaced or relocated water main to the CWD.

In consideration of the granting of this permit, the undersigned agrees:

1. That all construction has abided by all provisions of the Rules and Regulations for the Installation and Connection of Building Water Main and for the Use of Public Water Main of the City of Cambridge, Massachusetts, and all other pertinent rules and regulations that may be adopted in the future.
2. That all construction for water main was developed at no expense to the City.

Date: \_\_\_\_\_ Signed: \_\_\_\_\_  
(Applicant)

\_\_\_\_\_  
(Address of Applicant)

\$ \_\_\_\_\_ inspection fee paid.

Application approved and permit issued: Number: \_\_\_\_\_

Date: \_\_\_\_\_ Signed: \_\_\_\_\_  
Managing Director

## **APPENDIX C**

### **DISINFECTING WATER MAINS**

## SUMMARY OF “AWWA STANDARD FOR DISINFECTING WATER MAINS”

### GENERAL

According to the Standard for Disinfecting Water Mains (e.g. AWWA C651), all new water mains and those water mains taken out of service for inspecting, repairing or other activity that might lead to contamination of water should be disinfected before they are placed in service.

The basic disinfecting procedure consists of:

1. Preventing contamination material from entering the water main during storage, construction or repair.
2. Removing, by flushing or other means, those materials that may enter the water mains.
3. Chlorinating any residual contamination that may remain and flushing the chlorinated water from the main.
4. Determining the bacteriological quality by laboratory test after disinfecting. Re-disinfecting and re-sampling are needed if the initial disinfecting fails to produce satisfactory bacteriological samples.

### METHOD

The general application of disinfecting water mains is the continuous-feed method. This method consists of placing calcium hypochlorite granules in the main, preliminary flushing the complete main to remove particles and chlorinating the main.

- *Placing calcium hypochlorite granules:* During construction, calcium hypochlorite granules shall be placed at the upstream end of the first section of pipe, at the upstream end of each branch main and at 500-ft. intervals. The quantity of granules is shown in Table 1.

Table 1: Quantity of calcium hypochlorite granules to be placed at the beginning of main and at each 50-ft. interval.

Pipe Diameter (in.)	Calcium Hypochlorite Granules (oz.)
4	0.5
5	1.0
8	2.0
12	4.0
16 or larger	8.0



- *Preliminary flushing:* Before being chlorinated, the main shall be filled to eliminate air pockets and shall be flushed to remove particulate. The flushing velocity in the main shall not be less than 2.5 ft./s unless under the conditions which do not permit the required flow to be discharged to waste. Table 2 shows the rates of flow required to produce a velocity of 2.5 ft./s in pipes of various sizes.

Table 2: Required flow and openings to flush pipelines (40 psi residual pressure in water Main\*).

Pipe Diameter in	Flow Required to Produce 2.5 ft./s Velocity in Main gpm	Size of Tap in			Number of 2.5-in Hydrant Outlet*
		1	1.5	2	
4	100	1	-	1	1
6	200	-	1	-	1
8	400	-	2	1	1
10	600	-	3	2	1
12	900	-	-	2	2
16	1600	-	-	4	2

\*With a 40-psi pressure in the main with the hydrant flowing to atmosphere, a 2.5-in. hydrant outlet will discharge approximately 100 gpm and 4.5-in. hydrant outlet will discharge approximately 2500 gpm. Number of taps on pipe based on discharge through 5-ft. of galvanized iron pipe with one 90 degree elbow.

- *Chlorinating the main:* Before the main is to be chlorinated, water from the existing distribution systems or other approved source of supply shall be made to flow at a constant, measured rate into the newly laid water main. In absence of a meter, the rate may be approximated by methods such as using a Pitot gauge in the discharge, or measuring the trajectory of the discharge (Figure 1 in Appendix). Table 3 gives the amount of chemicals required for disinfecting each 100-ft of pipe with various diameters.

Table 3: Chlorine required producing 25 mg/L concentration in 100 ft. of pipe by diameter.

Pipe Diameter (in.)	Calcium Hypochlorite (65%) (lb.)	1% Chlorine Solution* (gal.)
4	0.03	0.16
6	0.06	0.36
8	0.11	0.65
12	0.25	1.44
16	0.46	2.60

\*1% chlorine solution requires 1 lb. of calcium hypochlorite (65%) in 8 gal. of water.

During the application of chlorine, water entering the new main shall receive a dose of chlorine fed at a constant rate, such that the water will have not less than 25 mg/L free chlorine at a point not more than 10 ft. downstream from the beginning of the new main. All valves shall be positioned so that strong chlorine solution in the main being treated will not flow into water mains in active service. Chlorination shall not cease until entire main is filled with heavily chlorinated water. The chlorinated water shall be retained in the main for at least 24 h, during which time all valves and hydrants in the treated section shall be operated to ensure disinfecting of the appurtenances. At the end of this 24-h period, the treated water in all portions of the main shall have a residual of not less than 10-mg/L free chlorine.

## **FINAL FLUSHING**

- *Clearing the main of heavily chlorinated water:* After the applicable retention period, heavily chlorinated water shall be flushed out from the main until the chlorine residual in the water leaving the main is no higher than the generally prevailing in the system or is acceptable for domestic use.
- *Disposing of heavily chlorinated water:* The environment to which the chlorinated water is to be discharged shall be inspected. A reduce agent (Table B1 in Appendix) shall be applied to neutralize the chlorine residual remaining in the water if there is any question that chlorinated discharge will cause damage to the environment.

## **BACTERIOLOGICAL TESTS**

- *Sampling conditions:* After final flushing and before the water main is to be placed in service, samples shall be collected from the end of new main and each branch if there is any, shall be tested for bacteriological quality in accordance with *Standard Methods for the Examination of Water and Wastewater*, and shall show the absence of coliform organisms. In case of extremely long main, it is desirable that samples be collected along the length of the lines as well as its end.
- *Sampling procedure:* Samples for bacteriological analysis shall be collected in sterile bottles treated with sodium thiosulfate as required by *Standard Methods for the Examination of Water and Wastewater*. The chlorine residual in the water shall be measured and the sampling tap shall be cleaned before the sample is collected. No hose or fire hydrant shall be used in collection of samples. A suggested combination blow-off and sampling tap is shown in Figure 1. A corporation cock may be installed in the main with a copper tube gooseneck assembly. After samples have been collected, the gooseneck assembly may be removed and retained for future use.

## APPENDIX D

### WATER MAIN INSTALLATION DETAIL

# WATER MAIN TRENCH DETAIL

NOT TO SCALE

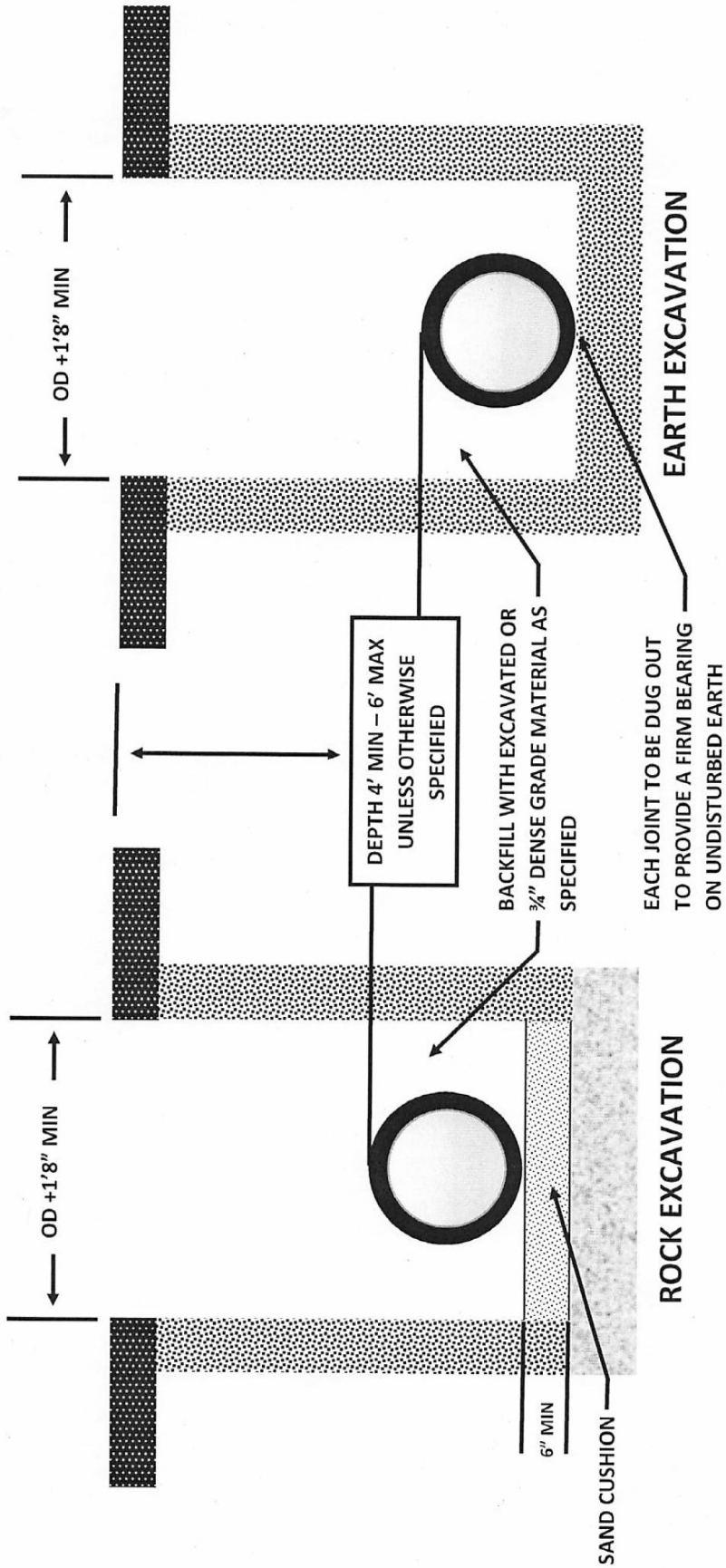

CAMBRIDGE WATER DEPARTMENT  
WATER WORKS STANDARDS

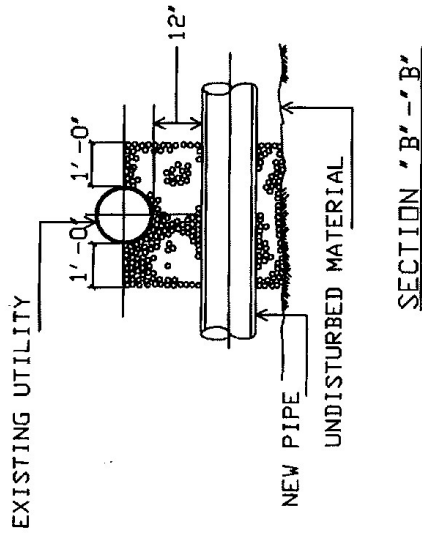
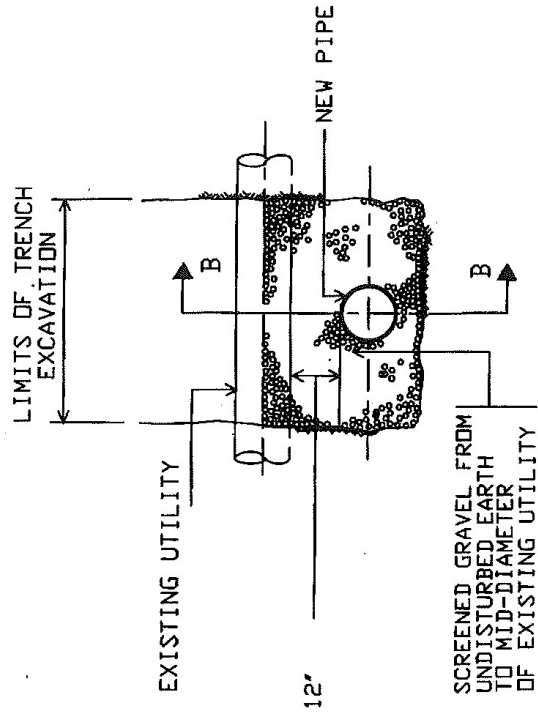

TYPICAL SECTION  
TYPICAL UTILITIES CROSSING DETAIL  
NOT TO SCALE

FILENAME: ..... \ XING\_TY.dwg

# CAMBRIDGE WATER DEPARTMENT WATER WORKS STANDARDS

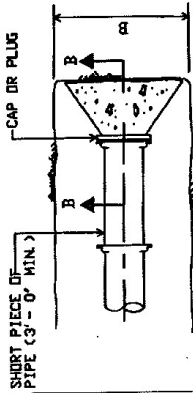

PLAN - PLUG

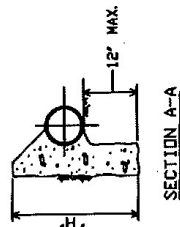

SECTION A-A

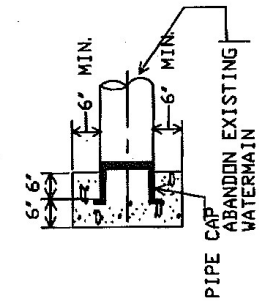

SECTION B-B

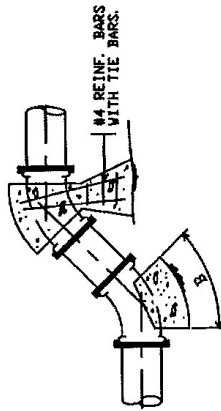

ELEVATION - VERTICAL BENDS

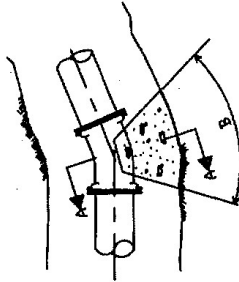

PLAN - HORIZONTAL BEND

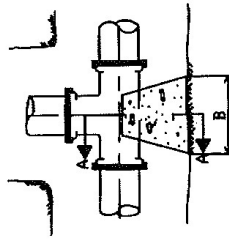

PLAN - TEE

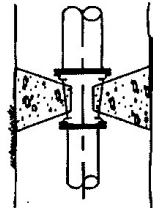

PLAN - REDUCER  
(OPTIONAL)

## CONCRETE PLUG FOR ABANDONED PIPE

FITTING	MIN. BEARING AREA "H" x "B"
12" x 12" TEE	3' x 3'
12" x 10" TEE	2.5' x 2.5'
12" x 8" TEE	2' x 2'
12" x 6" TEE	1.5' x 1.5'
10" x 6" TEE	1.5' x 1.5'
8" x 6" TEE	2' x 2'
8" x 6" TEE	1.5' x 1.5'
12" x 8" RED.	2.5' x 2.5'
12" x 6" RED.	2.5' x 2.5'
8" x 6" RED.	1.5' x 1.5'
12" x 6" TS & V	1.5' x 1.5'
12" - 1/4 BEND	3' x 3'
12" - 7 BEND	2.5' x 2.5'
12" - 1 BEND	2' x 2'
12" - 1/2 BEND	1.5' x 1.5'
10" - 1/8 BEND	2' x 2.5'
8" - 1 BEND	1.5' x 1.5'
8" - 1/16 BEND	1.5' x 1.5'
6" - 1 BEND	1.5' x 1.5'
6" - 1/8 BEND	1.5' x 1.5'

## CONCRETE ANCHORAGE DETAILS

NOT TO SCALE

NOTE:  
ALL CONCRETE TO BE PLACED  
AGAINST UNDISTURBED EARTH

FILENAME: ... ADMIN.JET.DWG

CAMBRIDGE WATER DEPARTMENT  
WATER WORKS STANDARDS

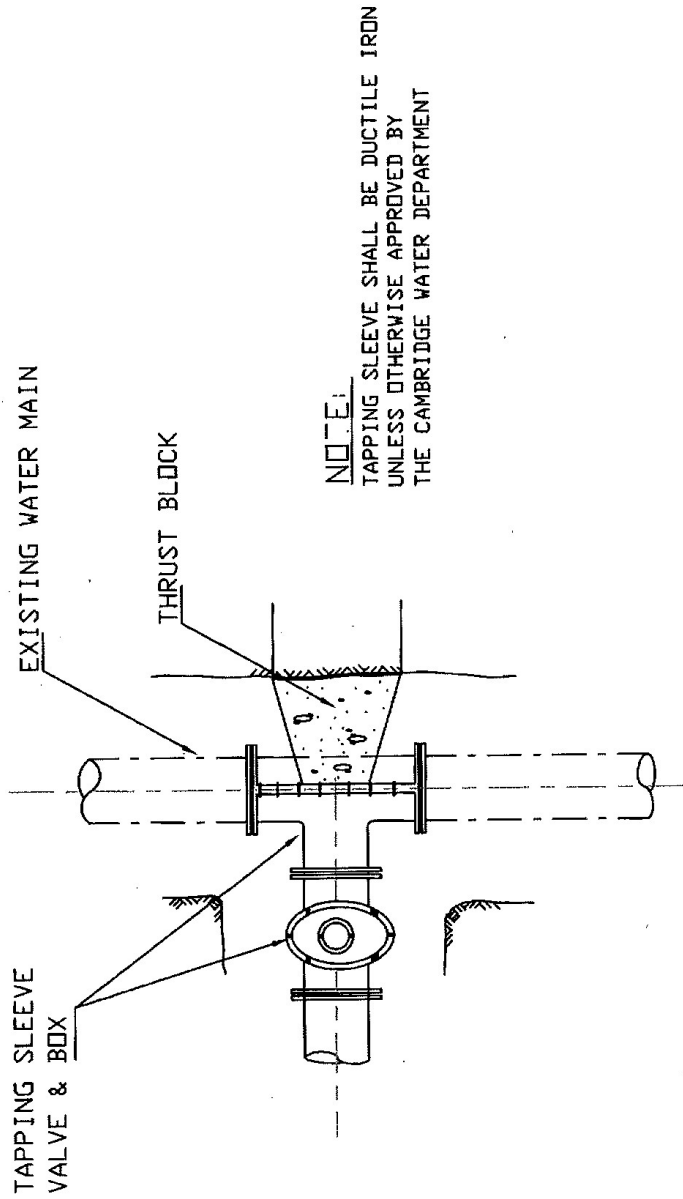

CONNECTION TO EXISTING MAIN  
NOT TO SCALE

FILENAME: ... \CDWR\_MAIN.DWG

CAMBRIDGE WATER DEPARTMENT  
WATER WORKS STANDARDS

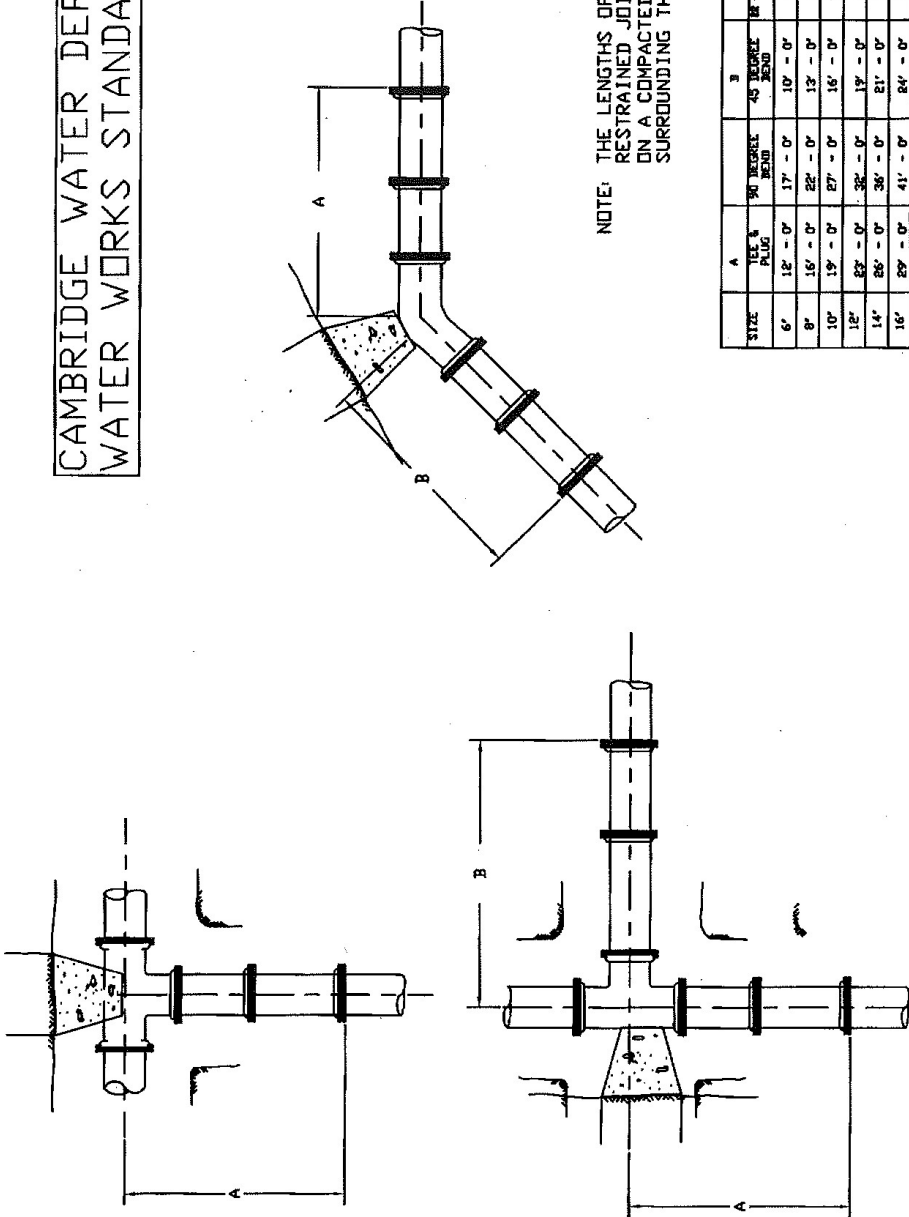

NOTE: THE LENGTHS OF PIPE WITH RESTRAINED JOINTS ARE BASED ON A COMPACTED SILTY SOIL SURROUNDING THE PIPE

PIPE SIZE	B			A		
	90 DEGREE BEND	45 DEGREE BEND	11-1/2" BEND PLUG	TEE & PLUG	90 DEGREE BEND	45 DEGREE BEND
6"	12' - 0"	17' - 0"	8' - 0"	12' - 0"	17' - 0"	8' - 0"
8"	16' - 0"	22' - 0"	8' - 0"	16' - 0"	22' - 0"	8' - 0"
10"	19' - 0"	27' - 0"	9' - 0"	19' - 0"	27' - 0"	9' - 0"
12"	22' - 0"	32' - 0"	9' - 0"	22' - 0"	32' - 0"	9' - 0"
14"	25' - 0"	36' - 0"	11' - 0"	25' - 0"	36' - 0"	11' - 0"
16"	29' - 0"	41' - 0"	11' - 0"	29' - 0"	41' - 0"	11' - 0"
18"	32' - 0"	45' - 0"	12' - 0"	32' - 0"	45' - 0"	12' - 0"
20"	35' - 0"	50' - 0"	12' - 0"	35' - 0"	50' - 0"	12' - 0"
24"	41' - 0"	58' - 0"	13' - 0"	41' - 0"	58' - 0"	13' - 0"
30"	50' - 0"	70' - 0"	15' - 0"	50' - 0"	70' - 0"	15' - 0"
36"	58' - 0"	82' - 0"	16' - 0"	58' - 0"	82' - 0"	16' - 0"
42"	66' - 0"	93' - 0"	17' - 0"	66' - 0"	93' - 0"	17' - 0"

CONCRETE ANCHORAGE DETAILS  
NOT TO SCALE

FILENAME: .....VREST\_JOINT.DWG



# CAMBRIDGE WATER DEPARTMENT WATER WORKS STANDARDS

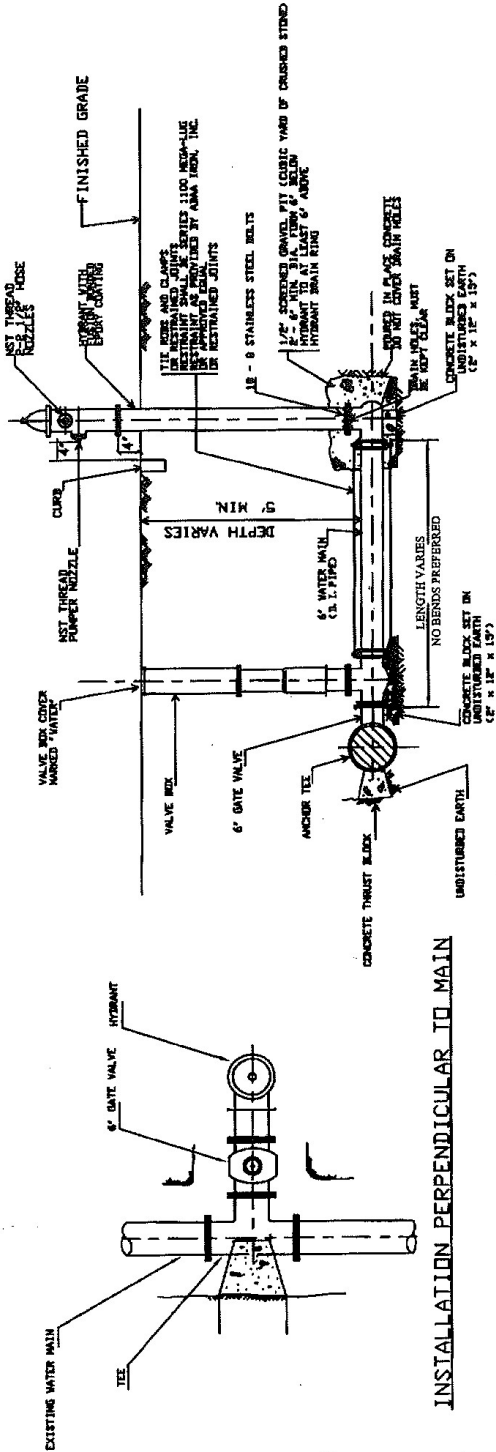

## ELEVATION STANDARD CONNECTION

- NOTES:
1. TIE RODS AND CLAMPS, RESTRAINED JOINTS, DUCTILE IRON PIPE WITH THRUST BLOCKS OR COMBINATIONS OF THESE MAY BE USED WHERE ADDITIONAL RESTRAINING/ANCHORAGES IS REQUIRED
  2. HYDRANTS SHALL BE SAME MODEL CURRENTLY USED BY CAMBRIDGE WATER DEPARTMENT (CWD)

## TYPICAL FIRE HYDRANT DETAILS NOT TO SCALE

FILENAME: "WATER BN SKETCH".....VW1\_0671.DWG

# CAMBRIDGE WATER DEPARTMENT WATER WORKS STANDARDS

## SECTION 12. GATE BOXES

Valves shall be provided for each gate valve and tapping sleeve and valve. Valve boxes shall be cast iron and of the telescopic design with two piece construction, top with a cover and a bottom. The top section shall have a top flange to increase the stability of the box to remain at present height. The lower section of the box shall have a bell shaped bottom designed to enclose the operating nut and stuffing box of the valve without setting. The gate box shall come complete with cover on which the word "WATER" shall be cast. The cover of the gate box shall be close fitting and substantially air-tight and flush with the top of the box rim. Gate boxes shall be installed for each buried valve. Valve boxes shall be CP. Test Services, Inc., or equal. Cast iron boxes shall be General Foundry Buffalo Boxes or equal.

SET TOP FLUSH  
WITH FINISH GRADE

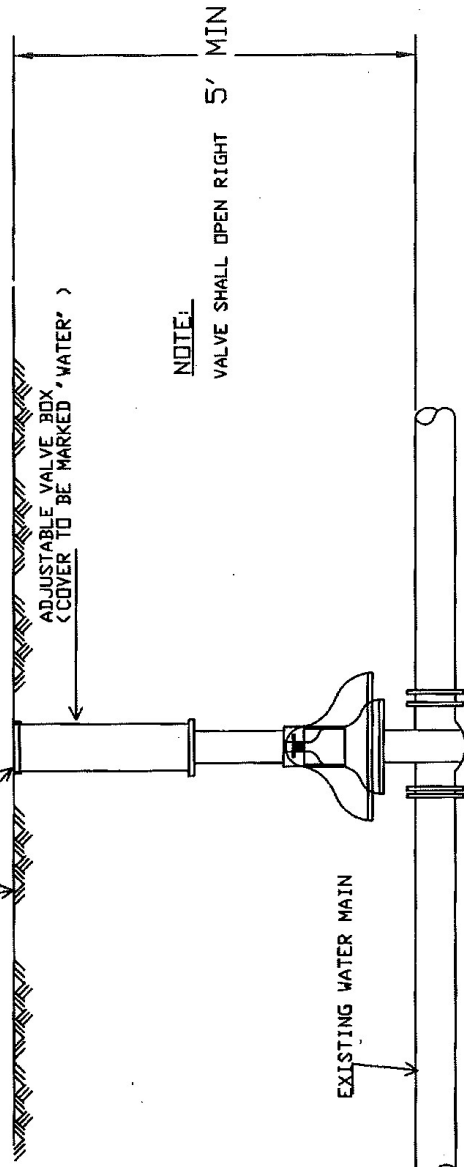

NOTE:

VALVE SHALL OPEN RIGHT 5' MIN

ELEVATION  
NOT TO SCALE

FILENAME.....\g\_boxes.dwg

**TYPICAL WATER LINE AND SEWER LINE CROSSING**

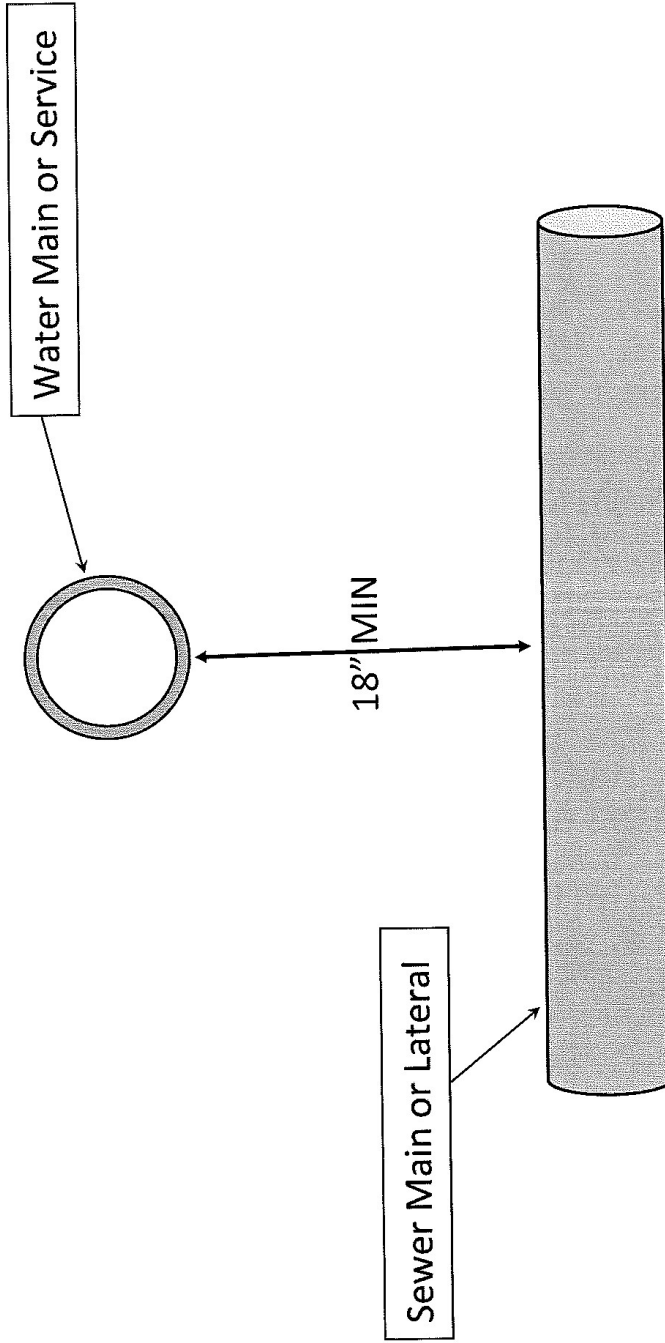

**SEWER CROSSINGS MUST CONFORM TO MASS DEP REGULATION #310 CMR 22.19**

**WATER DISTRIBUTION SYSTEMS REQUIREMENTS**

CAMBRIDGE WATER DEPARTMENT  
WATER WORKS STANDARDS

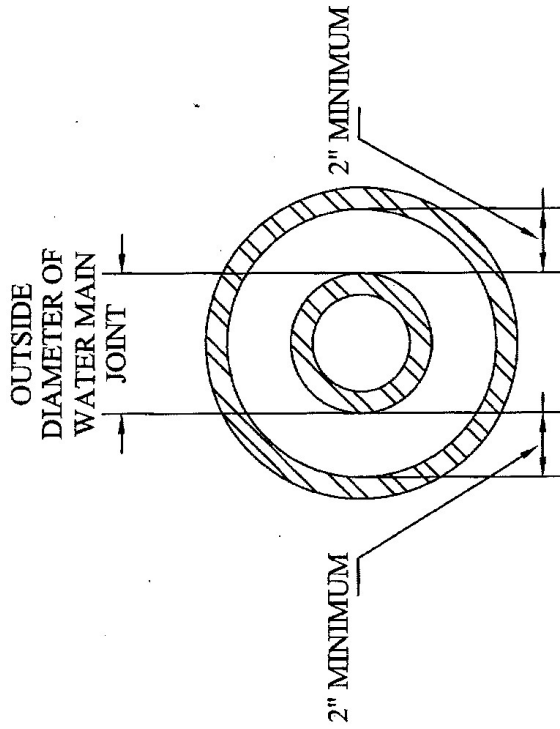

STEEL CASING DETAIL

DIAMETER OF CASING	WALL THICKNESS ( INCHES )	
	UNDER HIGHWAY	UNDER RAILROAD
UNDER 14'	0. 250	0. 188
14'	0. 250	0. 219
16'	0. 250	0. 219
18'	0. 250	0. 250
20'	0. 375	0. 281
22'	0. 375	0. 312
24'	0. 375	0. 344
26'	0. 375	0. 375
28'	0. 500	0. 406
30'	0. 500	0. 406
32'	0. 500	0. 438
34'	0. 500	0. 469
36'	0. 500	0. 469
38'	0. 500	0. 500
40'	0. 500	0. 500
42'	0. 500	0. 500

FILENAME: 'WATER DN SHOOPY'.....\STEEL\_CAS.DWG

CAMBRIDGE WATER DEPARTMENT  
WATER WORKS STANDARDS

RECIPE FOR 1% CHLORINE SOLUTION

- 0.8 gal of 12% sodium hypochlorite in 10 gal of water
- 2.86 gal of bleach (5.25% sodium hypochlorite) in 10 gal of water

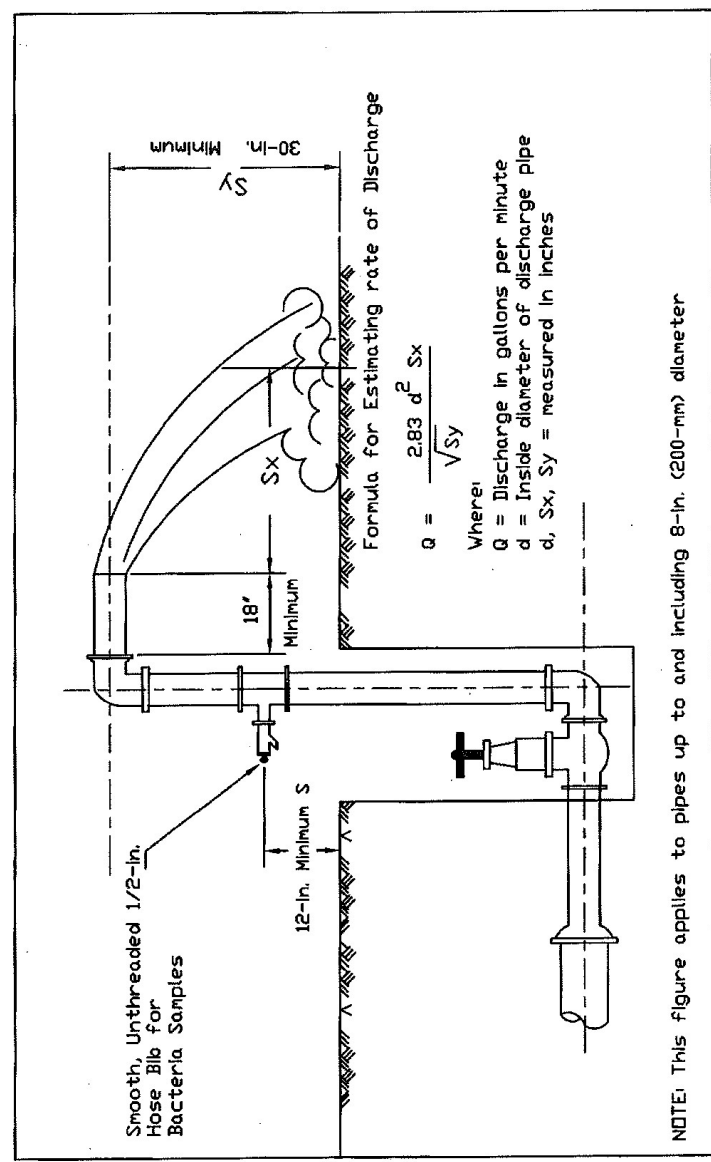

NOTE: This figure applies to pipes up to and including 8-in. (200-mm) diameter

SUGGESTED COMBINATION BLOWOFF AND SAMPLING TAP  
NOT TO SCALE

FILENAME... VGC\_CHORLINE.JPG

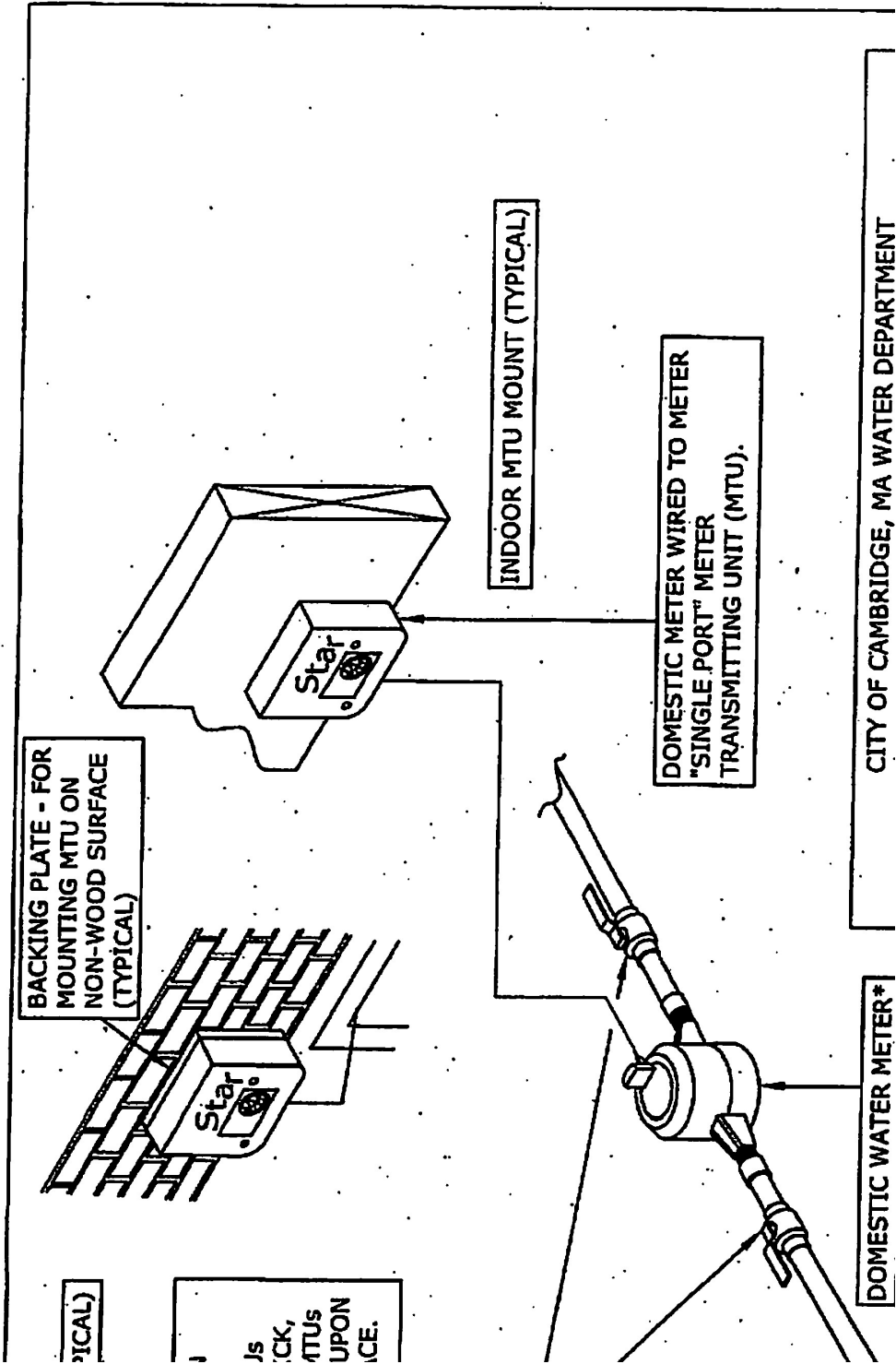

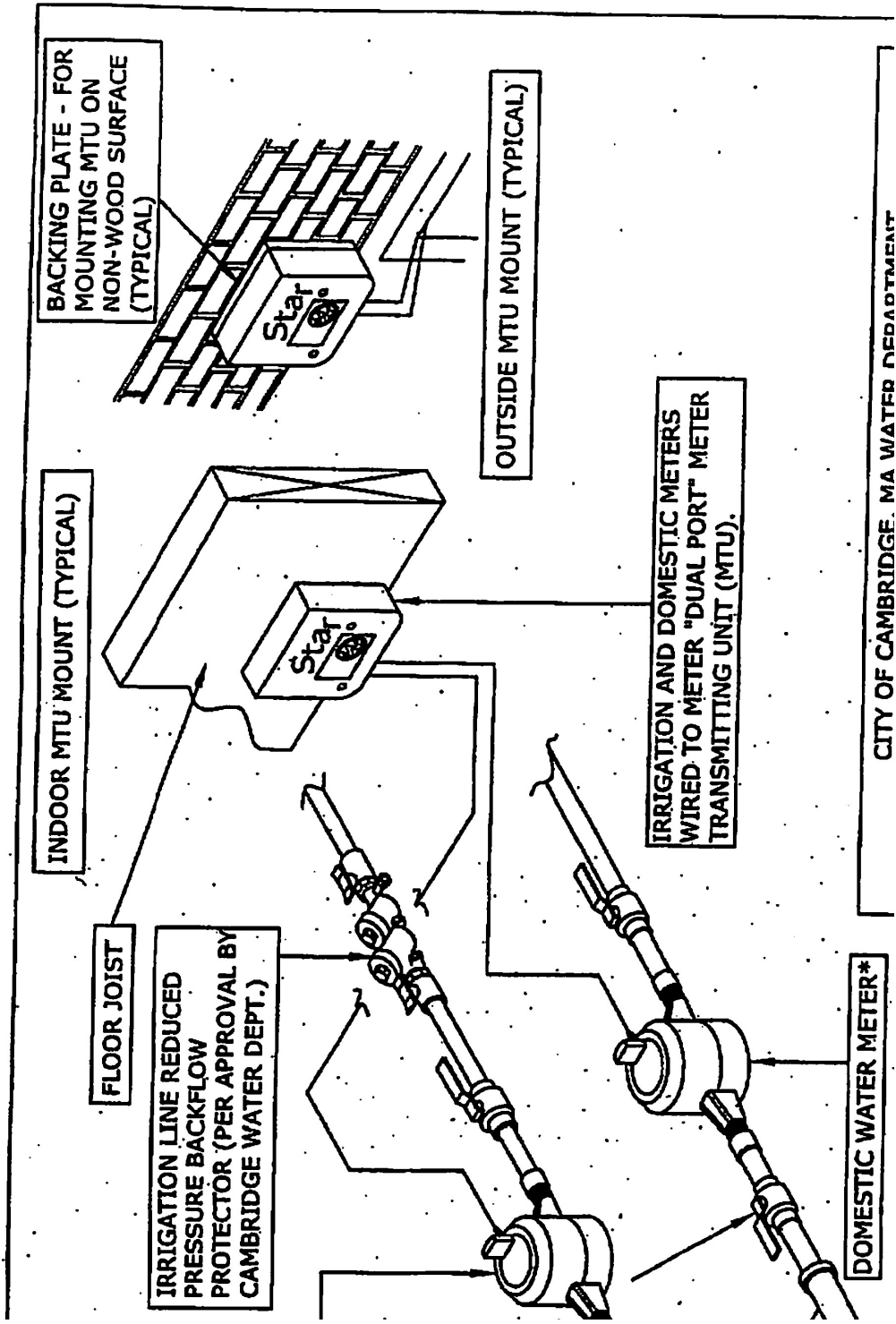

INDOOR MTU MOUNT (TYPICAL)

FLOOR JOIST

IRRIGATION LINE REDUCED PRESSURE BACKFLOW PROTECTOR (PER APPROVAL BY CAMBRIDGE WATER DEPT.)

DOMESTIC WATER METER\*

IRRIGATION AND DOMESTIC METERS WIRED TO METER "DUAL PORT" METER TRANSMITTING UNIT (MTU).

BACKING PLATE - FOR MOUNTING MTU ON NON-WOOD SURFACE (TYPICAL)

OUTSIDE MTU MOUNT (TYPICAL)

CITY OF CAMBRIDGE, MA WATER DEPARTMENT

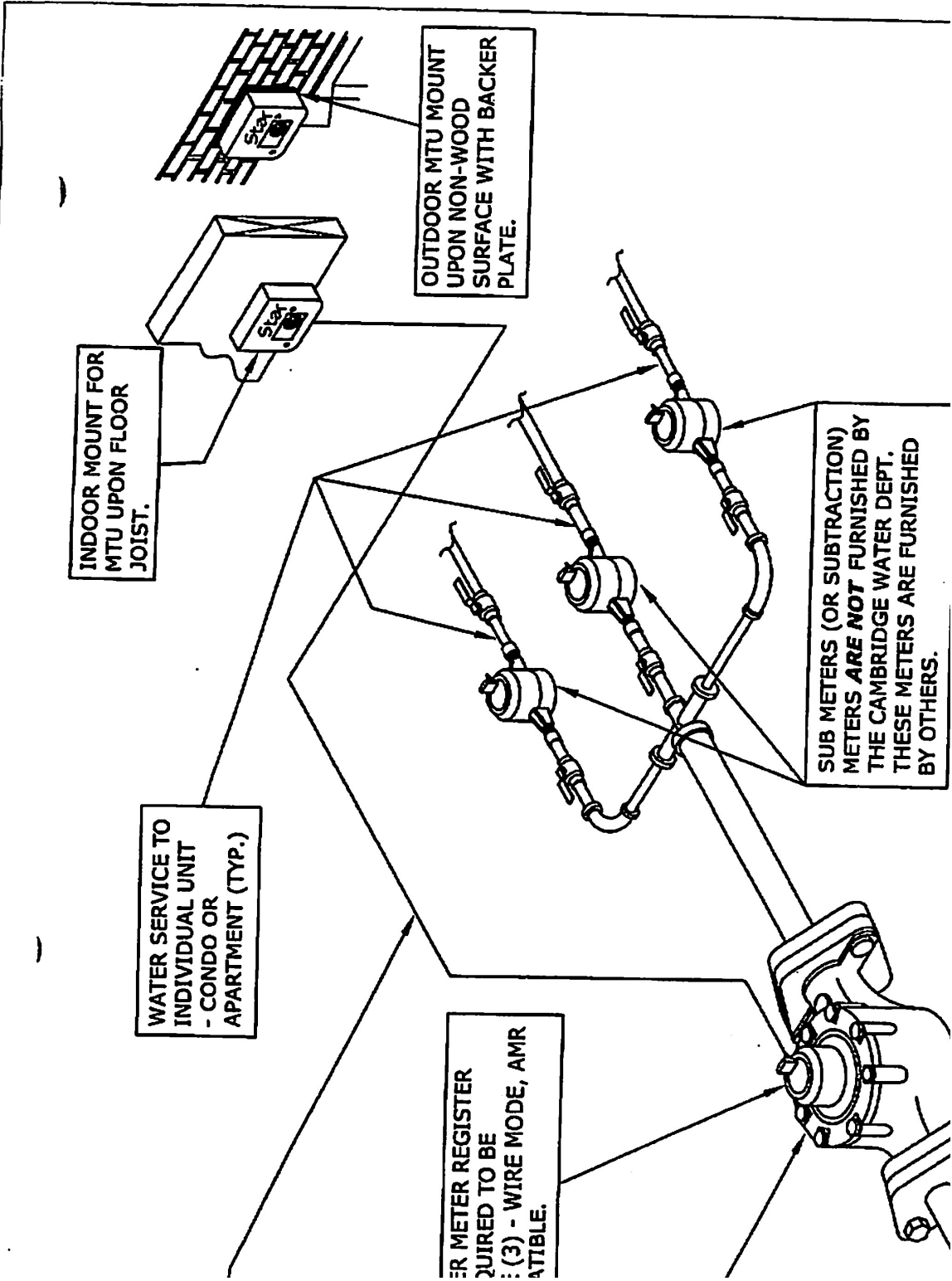

INDOOR MOUNT FOR  
MTU UPON FLOOR  
JOIST.

OUTDOOR MTU MOUNT  
UPON NON-WOOD  
SURFACE WITH BACKER  
PLATE.

WATER SERVICE TO  
INDIVIDUAL UNIT  
- CONDO OR  
APARTMENT (TYP.)

METER REGISTER  
REQUIRED TO BE  
WIRE MODE, AMR  
METER.

SUB METERS (OR SUBTRACTION)  
METERS ARE NOT FURNISHED BY  
THE CAMBRIDGE WATER DEPT.  
THESE METERS ARE FURNISHED  
BY OTHERS.



CAMBRIDGE WATER DEPARTMENT  
WATER WORKS STANDARDS

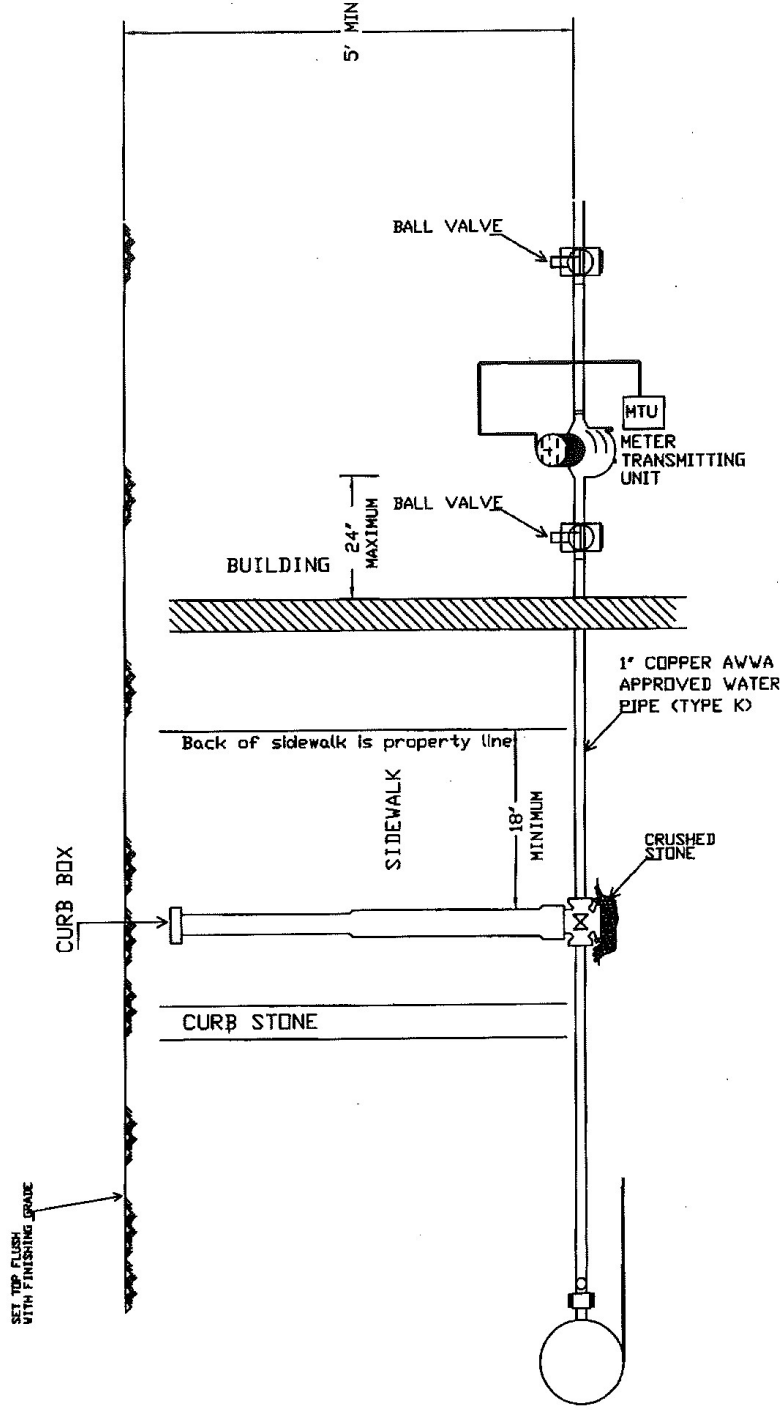

TYPICAL 1" SERVICE & METER INSTALLATION  
NOT TO SCALE

FILENAME: ..... \SERV\_CONN.DWG

CAMBRIDGE WATER DEPARTMENT  
WATER WORKS STANDARDS

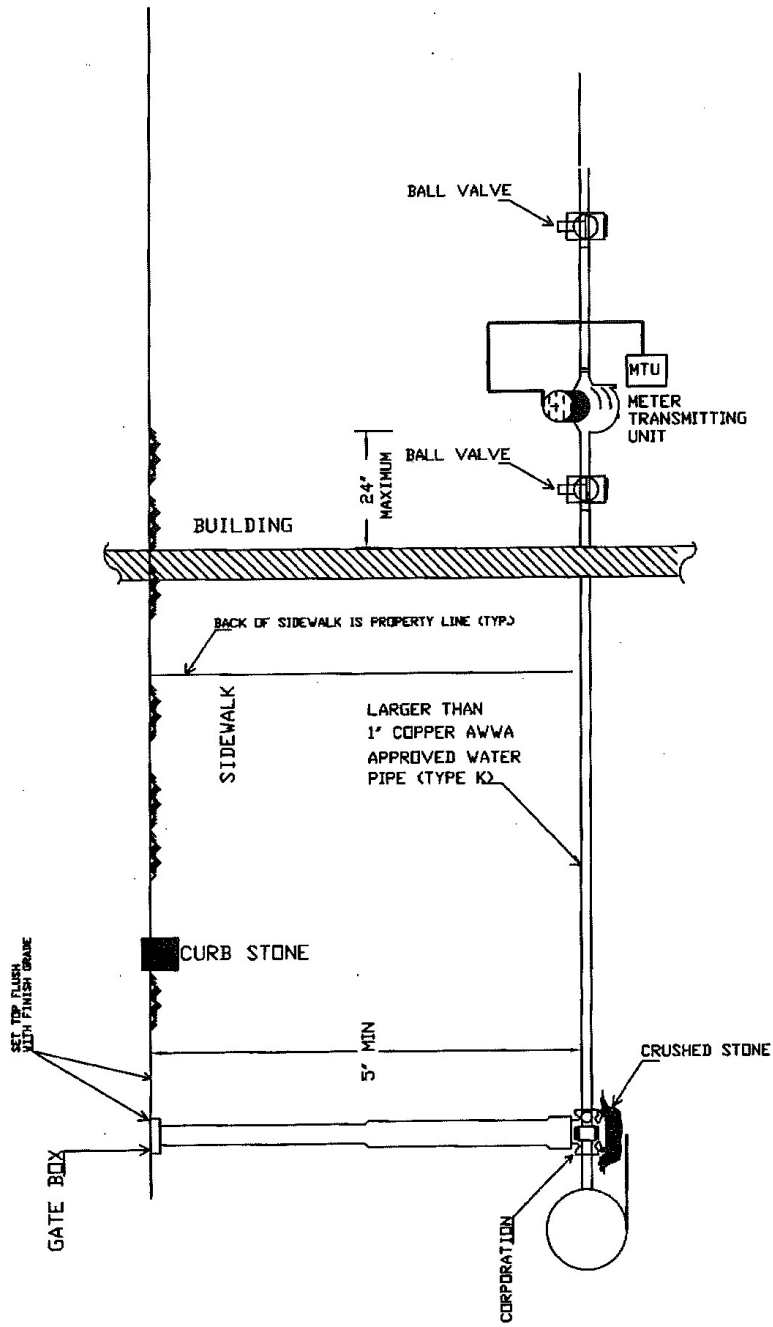

TYPICAL LARGER THAN 1" SERVICE & METER INSTALLATION  
NOT TO SCALE

FILENAME: SERV\_CONN1.DWG

# USH. ASSEMBLY

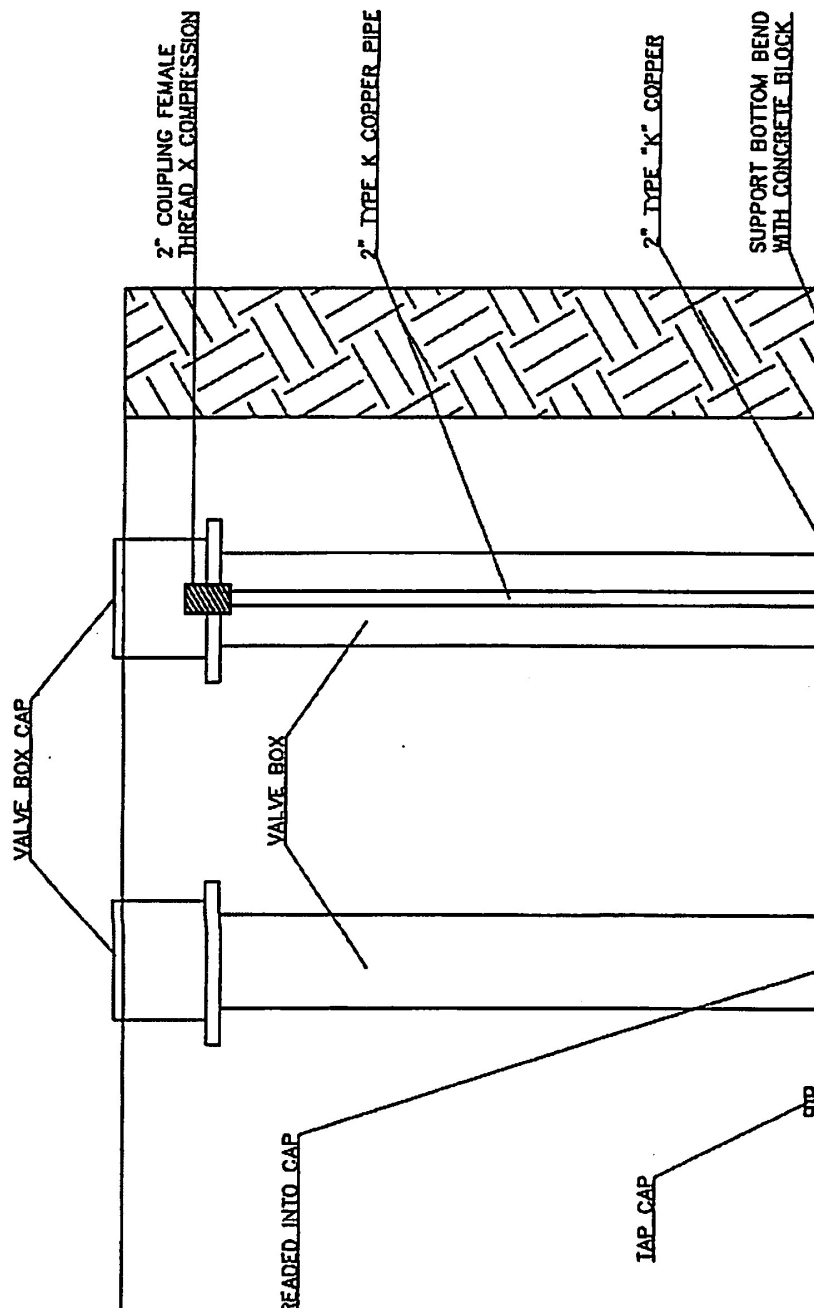

# WATER SUPPLY CABINET FOR IRRIGATION, WATER FOUNTAINS AND WATER FEATURES CAMBRIDGE WATER DEPARTMENT MINIMUM REQUIREMENTS

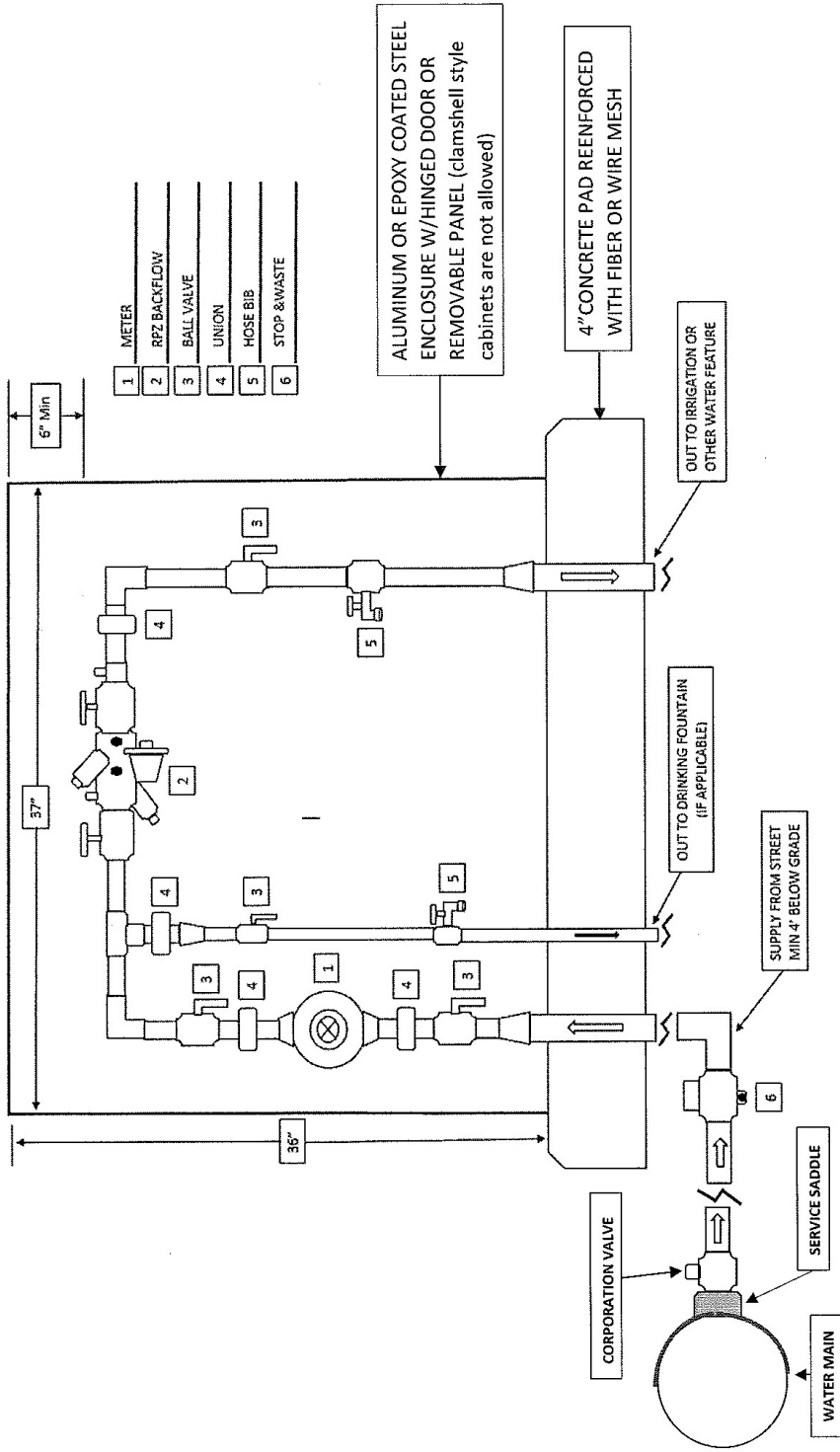

NOT TO SCALE

CAMBRIDGE WATER DEPARTMENT

WATER TIES

COMPANY NAME: \_\_\_\_\_

DATE JOB COMPLETED: \_\_\_\_\_

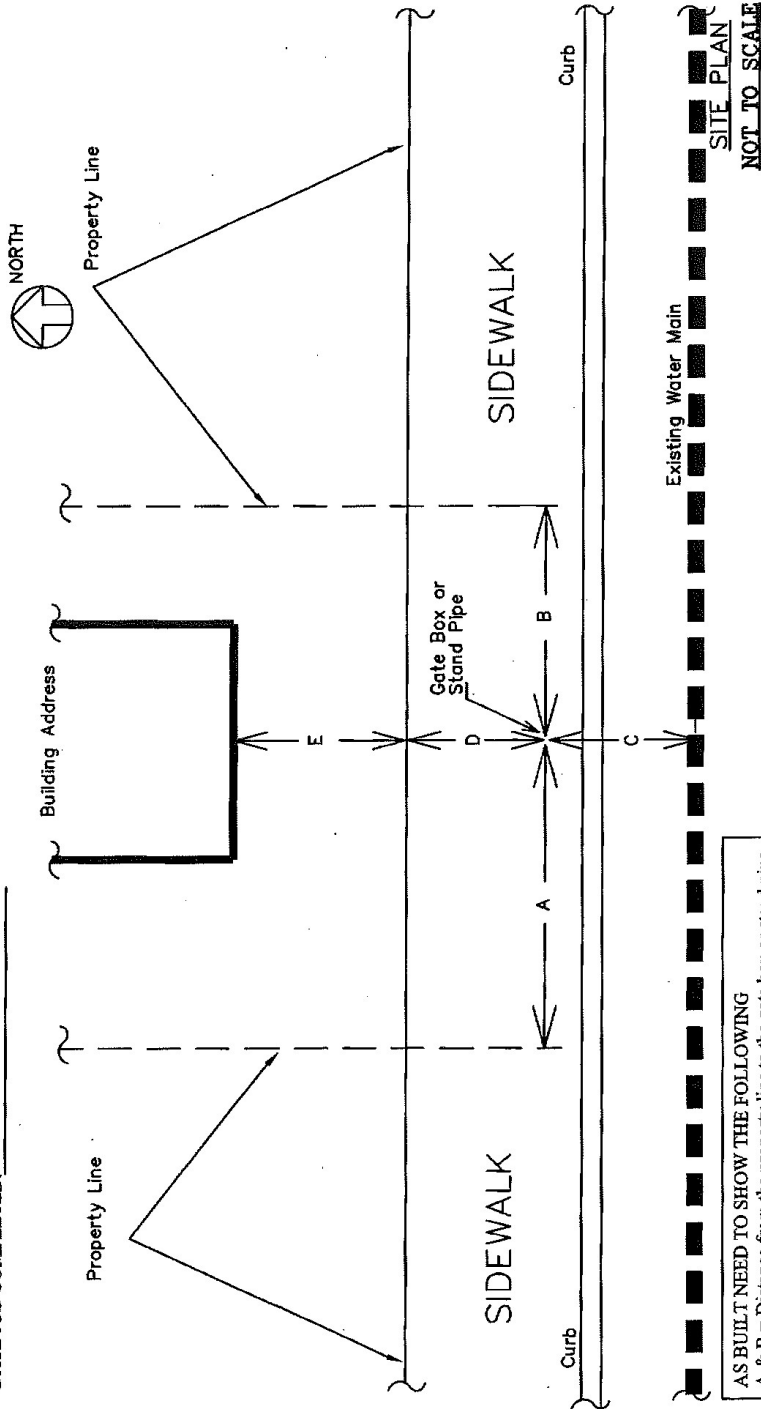

AS BUILT NEED TO SHOW THE FOLLOWING  
A & B = Distance from the property line to the gate box or stand pipe  
C = Distance from existing main to gate box or stand pipe  
D = Distance from property line to gate box or stand pipe  
E = Distance from property line to the Building

Also need to show  
Size of the service lines, material  
Building address

SITE PLAN  
NOT TO SCALE

# **APPENDIX E**

## **CITY OF CAMBRIDGE PERMIT CONTACTS**

# CITY OF CAMBRIDGE PERMIT CONTACTS

*Last updated March 11, 1999*

**ANIMAL COMMISSION**, City Hall Annex, 51 Inman Street

Phone: 349-4376; Fax: 349-4669; TTY: 492-4621

**ARTS COUNCIL**, City Hall Annex, 57 Inman Street

Phone: 349-4380; Fax: 349-4669; TTY: 492-4621

**CITY CLERK**, City Hall, 795 Massachusetts Avenue, 1<sup>st</sup> Fl.

Phone: 349-4260; Fax: 349-4269; TTY: 349-4242

**CITY MANAGER'S OFFICE**, City Hall, 795 Massachusetts Avenue, 1<sup>st</sup> Fl.

Phone: 349-4300; Fax: 349-4307; TTY: 349-4242

**COMMUNITY DEVELOPMENT**, 57 Inman Street, 3<sup>rd</sup> Fl.

Phone: 349-4600; Fax: 349-4669; TTY: 492-4621

**CONSERVATION COMMISSION**, 57 Inman Street, 2<sup>nd</sup> Fl.

Phone: 349-4680; Fax: 349-4669; TTY: 492-4621

**DISABILITIES COMMISSION**, 51 Inman Street, 2<sup>nd</sup> Fl.

Phone: 349-4692; Fax: 349-4669; TTY: 492-0235

**ELECTRICAL DEPARTMENT**, 100 Smith Place (temporary location)

Phone: 349-4925; Fax: 349-4913; TTY: 492-0235

**FIRE DEPARTMENT**, 491 Broadway

Phone: 349-4918; Fax: 349-4912/TTY: 499-9924 or 9932

**HISTORICAL COMMISSION**, 831 Massachusetts Avenue; 2<sup>nd</sup> Fl.

Phone: 349-4683; Fax: 349-6165; TTY: 349-6112

**INSPECTIONAL SERVICES DEPT.**, 831 Massachusetts Avenue, and 1st Fl.

Phone: 349-6100; Fax: 349-6132; TTY: 349-6112

**LICENSE COMMISSION**, 831 Massachusetts Avenue, 1<sup>st</sup> Fl.

Phone: 349-6140; Fax: 349-6184; TTY: 349-6112

**POLICE DEPARTMENT**, 5 Western Avenue

Phone: 349-3331; Fax: 349-3335; TTY: 499-9924 or 9932

**PUBLIC HEALTH**, 119 Windsor Street

Phone: 498-1480; Fax: 498-1514; TTY: 498-1462

**PUBLIC WORKS**, 147 Hampshire Street

Phone: 349-4800; Fax: 349-4868; TTY: 349-4805

**RECREATION**, 51 Inman Street, 1<sup>st</sup> Fl.

Phone: 349-6238; Fax: 349-4868; TTY: 349-4805

**TRAFFIC, PARKING & TRANSPORTATION**, 57 Inman Street, 1<sup>st</sup> Fl.

Phone: 349-4700; Fax: 349-4747; TTY: 349-4621

**WATER DEPARTMENT**, 250 Fresh Pond Parkway

Phone: 349-4770; Fax: 349-4796; TTY: 492-0235



# **APPENDIX F**

## **DEMOLITION**

## DEMOLITION

### **Water Departments Requirements**

**The building to be demolished must be vacated.**

**All water service(s) shut off in the street.**

**All water meters removed and returned to Water Department for final billing.**

**All existing water services have to be addressed.**

**Copy of permit**

### **Procedure for obtaining a sign off on a demolition permit**

The owner or contractor calls the Water Department (617-349-4770) to schedule a water shut off and meter removal for final bill. An owner/contractor representative must be present.

If the building does not have a water service, an inspector will visit the site for confirmation. If the owner has a copy of the demolition permit to be supplied to the Water Department, the inspector may sign off and no further action will be required.

If the inspector determines there is a conflict with a water service line and the owner will not be re-using the service(s) the owner/contractor will be required to address the water service(s) with the following options:

A. Cut and cap all existing water lines at the source (at the main in the street). A \$60.00 water works construction permit and \$550.00 street opening permit (PWD) is required.

B. If the owner has intentions of reusing the existing water service(s) or a moratorium is in effect, delaying the cut & cap requirement, the owner may leave a returnable deposit of \$1000.00 for each existing water line. This deposit is to acknowledge responsibility if these lines were to be damaged during demolition. The CWD will hold the check, made out to The City of Cambridge until the construction is completed. In the event an incident occurs that requires the CWD to dispatch crews to make repairs during the construction, the cost of such work will be deducted from the deposit. Any balance will be returned to the owner at completion of the project.

# **APPENDIX G**

## **HYDROSTATIC TESTING**

## SECTION 4: HYDROSTATIC TESTING

*Warning: The testing methods described in this section are specific for water-pressure testing. These procedures should not be applied for air-pressure testing because of the serious safety hazards involved.*

### **Sec. 4.1 Pressure and Leakage Test**

- 4.1.1 *Test Restrictions:* Test pressure shall not be less than 1.50 times the working pressure at the highest point along the test section. Test pressure shall not exceed pipe or thrust-restraint design pressures. The hydrostatic test shall be of at least a 2-h duration. Test pressure shall not vary by more than  $\pm 5$  psi (34.5 kPa) for the duration of the test. Valves shall not be operated in either direction at a differential pressure exceeding the rated valve working pressure. Use of a test pressure greater than the rated valve pressure can result in trapped test pressure between the gates of a double-disc gate valve. For tests at these pressures, the test setup should include a provision, independent of the valve, to reduce the line pressure to the rated valve pressure on completion of the test. The valve can then be opened enough to equalize the trapped pressure with the line pressure or fully opened if desired. The test pressure shall not exceed the rated pressure of the valves when the pressure boundary of the test section includes closed, resilient-seated gate valves or butterfly valves.
- 4.1.2 *Pressurization:* After the pipe has been laid, all newly laid pipe or any valved section thereof, shall be subjected to a hydrostatic pressure of at least 1.5 times the working pressure at the point of testing. Each valved section of pipe shall be slowly filled with water; and the specified test pressure (based on the elevation of the lowest point of the line or section under test and corrected to the elevation of the test gauge), shall be applied by means of a pump connected to the pipe. Valves shall not be operated in either the opening or closing direction at differential pressures above the rated pressure. It is good practice to allow the system to stabilize at the test pressure before conducting the leakage test.
- 4.1.3 *Air Removal:* Before applying the specified test pressure, air shall be expelled completely from the section of piping under test. If permanent air vents are not located at all high points, corporation cocks shall be installed at such points so that the air can be expelled as the line is filled with water. After all the air has been expelled, the corporation cocks shall be closed and the test pressure applied. At the conclusion of the pressure test, the corporation cocks shall be removed and plugged or left in place as required by the specifications.
- 4.1.4 *Examination:* All exposed pipe, fittings, valves, hydrants and joints shall be examined carefully during the test. Any damage or defective pipe,

- 4.1.5 fittings, valves, hydrants or joints that are discovered following the pressure test shall be repaired or replaced with sound material; and the test shall be repeated until satisfactory results are obtained.
- 4.1.6 *Leakage defined:* Leakage shall be defined as the quantity of water that must be supplied into the newly laid pipe or any valved section thereof to maintain pressure within 5 psi (34.5 kPa) of the specified test pressure after the pipe has been filled with water and the air has been expelled. Leakage shall not be measured by a drop in pressure in a test section over a period of time.
- 4.1.7 *Allowable leakage:* No pipe installation will be accepted if the leakage is greater than that determined by the following formula:  
In inch/pound units,

$$L = \frac{SD \sqrt{P}}{133,200} \quad (\text{Eq 1})$$

Where:

- L* = allowable leakage, in gallons per hour  
*S* = length of pipe tested, in feet  
*D* = nominal diameter of the pipe, in inches  
*P* = average test pressure during the leakage test, in pounds per square inch (gauge)

# **APPENDIX H**

## **DIG SAFE**

THE COMMONWEALTH OF MASSACHUSETTS  
CHAPTER 82, SECTION 40

Effective 12/17/98

---

**Section 40.** The following words, as used in this section and sections 40A to 40E, inclusive, shall have the following meanings:

**“Company”**, natural gas pipeline company, petroleum or petroleum products pipeline company, public utility company, cable television company, and municipal utility company or department that supply gas, electricity, telephone, communication or cable television services or private water companies within the city or town where such excavation is to be made.

**“Description of excavation location”**, such description shall include the name of the city or town, street, way or route number where appropriate, the name of the streets at the nearest intersection to the excavation, the number of the buildings closest to the excavation or any other description, including landmarks, utility pole numbers or other information which will accurately define the location of the excavation.

**“Emergency”**, a condition in which the safety of the public is in imminent danger, such as a threat to life or health or where immediate correction is required to maintain or restore essential public utility service.

**“Excavation”**, an operation for the purpose of movement or removal of earth, rock or the materials in the ground including; but not limited to, digging, blasting, augering, back-filling, test boring, drilling, pile driving, grading, plowing, in hammering, pulling in, jacking in, trenching, tunneling and demolition of structures, excluding excavation by tools manipulated only by human power for gardening purposes and use of blasting for quarrying purposes.

**“Excavator”**, any entity including, but not limited to, a person, partnership, joint venture, trust, corporation, association, public utility, company or state or local government body which performs excavation operations.

**“Pre-mark”**, to delineate the general scope of the excavation or boring on the paved surface of the ground using white paint or stakes or other suitable white markings on non-paved surfaces. No pre-marking shall be acceptable if such marks can reasonably interfere with traffic or pedestrian control or are misleading to the general public. Pre-marking shall not be required of any continuous excavation that is over 500 feet in length.

**“Safety zone”**, a zone designated on the surface by the use of standard color-coded markings which contains the width of the facilities plus not more than 18-inches or, each side.

**“Standard color-coded markings”**, red – electric power lines, cables, conduit or light cables; yellow – gas, oil, street petroleum, or other gaseous materials; orange – communications cables or conduit, alarm or signal lines; blue – water, irrigation and slurry lines; green – sewer and drain lines; white – pre-mark of proposed excavation.

**“System”**, the underground plant-damage prevention system as defined in Section 76D of Chapter 164.

**Section 40A.** No excavator installing a new facility or an addition to an existing facility or the relay or repair of an existing facility shall, except in an emergency, make an excavation, in any public or private way, any company right-of-way or easement or any public or privately owned land or way, unless at least 72 hours, exclusive of Saturdays, Sundays and legal holidays; but not more than 30 days before the proposed excavation is to be made, such excavator has pre-marked not more than 500 feet of the proposed excavation and given an initial notice to the system. Such initial notice shall set forth a description of the excavation location in the manner as herein defined. In addition, such initial notice shall indicate whether any such excavation will involve blasting and, if so, the date and the location at which such blasting is to occur.

The notice requirements shall be waived in an emergency as defined herein; provided, however, that before such excavation begins or during a life-threatening emergency, notification shall be given to the system and the initial point of boring or excavation shall be pre-marked. The excavator shall ensure that the underground facilities of the utilities in the area of such excavation shall not be damaged or jeopardized.

In no event shall any excavation by blasting take place unless notice thereof, either in the initial notice or a subsequent notice accurately specifying the date and location of such blasting; shall have been given and received at least 72 hours in advance, except in the case of an unanticipated obstruction requiring blasting when such notice shall be not less than four hours prior to such blasting. If any such notice cannot be given as aforesaid because of an emergency requiring blasting, it shall be given as soon as may be practicable but before any explosives are discharged.

**Section 40B.** Within 72 hours, exclusive of Saturdays, Sundays and legal holidays, from the time the initial notice is received by the system or at such time as the company and the excavator agree, such company shall respond to the initial notice or subsequent notice by designating the location of the underground facilities within 15 feet in any direction of the pre-marking so that the existing facilities are to be found within a safety zone. Such safety zone shall be so designated by the use of standard color-coded markings. The providing of such designation by the company shall constitute prima facie evidence of an exercise of reasonable precaution by the company as required by this section; provided, however, that in the event that the excavator has given notice as aforesaid at a location at which because of the length of excavation the company cannot reasonable designate the entire location of its facilities within such 72 hour period, then such excavator shall identify for the company that portion of the excavation which is to be first made and the company shall designate the location of its facilities in such portion within 72 hours and



designate the location of its facilities in the remaining portion of the location within a reasonable time thereafter. When an emergency notification has been given to the system, the company shall make every attempt to designate its facilities as promptly as possible.

**Section 40C.** After a company has designated the location of its facilities at the location in accordance with Section 40B, the excavator shall be responsible for maintaining the designation markings at such locations, unless such excavator requests remarking at the location due to the obliteration, destruction or other removal of such markings. The company shall then remark such location within 4 hours following receipt of such request.

When excavating in close proximity to the underground facilities of any company, when such facilities are to be exposed, non-mechanical means shall be employed, as necessary, to avoid damage in locating such facility; and any further excavation shall be performed employing reasonable precautions to avoid damage to any underground facilities including, but not limited to, any substantial weakening of structural or lateral support of such facilities, penetration or destruction of any pipe, main, wire or conduit or the protective coating thereof, or damage to any pipe, main, wire or conduit.

If any damage to such pipe, main wire or conduit or its protective coating occurs, the company shall be notified immediately by the excavator responsible for causing such damage.

The making of an excavation without providing the notice required by Section 40A with respect to any proposed excavation, which results in any damage to a pipe, main, wire or conduit, or its protective coating, shall be prima facie evidence in any legal or administrative proceeding that such damage was caused by the negligence of such person.

**Section 40D.** Nothing contained herein shall be construed to affect or impair local ordinances or by-laws requiring permits to be obtained before excavation in a public way; provided, however, that notwithstanding any contrary provision of local ordinances or by-laws, no permit to excavate in a public way shall be approved or issued by the officer or board having charge of any such way, except in an emergency as herein defined; until such time as proof of such notices to the system have been filed with such officer or board by the applicant for the permit as required by this section and notice of issuance of a permit to excavate have been served by such officer or board upon the appropriate water and sewer department.

**Section 40E.** Any person or company found by the department of telecommunications and energy, after a hearing, to have violated any provision of Sections 40A to 40E, inclusive, shall be fined \$500 for the first offense and not less than \$1,000 nor more than \$5,000 for any subsequent offense within 12 consecutive months as set forth by the rules of said department; provided, however, that nothing herein shall be construed to require forfeiture of any penal sum by a state or local government body for violation of Section

40A or 40C; and provided, further, that nothing herein shall be construed to require the forfeiture of any penal sum by a residential property owner for the failure to pre-mark for an excavation on such person's residential property.

.....

DIG SAFE SYSTEM, INC.  
*Utility Underground Plant Damage  
Prevention System*

**APPENDIX I**

## **TRENCHING, BACKFILL AND COMPACTION**

### **TRENCHING, BACKFILLING AND COMPACTION**

#### **PART 1: GENERAL**

##### **1.01 SCOPE OF WORK**

A Furnish all labor, materials, equipment and incidentals necessary to perform all trenching for pipelines and appurtenances, including drainage, filling, backfilling, disposal of surplus material and restoration of trench surfaces and easements.

B Excavation shall extend to the width and depth as specified by the Cambridge Water Department and shall provide suitable room for installing pipe, structures and appurtenances.

C The Contractor shall furnish and place all sheeting, bracing and supports and shall remove from the excavation all materials which the Cambridge Water Department may deem unsuitable for backfilling. The bottom of the excavation shall be firm, dry and in all respects, acceptable. If conditions warrant, the Contractor may be ordered to deposit gravel for pipe bedding, or gravel refill for excavation below grade, directly on the bottom of the trench immediately after excavation has reached the proper depth and before the bottom of the trench has become softened or disturbed by any cause whatever. The length of open trench shall be related closely to the rate of pipe laying. All excavation shall be made in open trenches.

D All excavation, trenching, and related sheeting, bracing, etc. shall comply with the requirements of OSHA excavation safety standards (29 CFR Part 1926.650 Subpart P) and State requirements. Where conflict between OSHA and State regulations exists, the more stringent requirements shall apply.

E Wherever the requirement for 95 percent compaction is referred to herein it shall mean "at least 95 percent of maximum density as determined by ASTM D1557, Method D".

F Prior to the start of work the Contractor is required to submit his proposed method of backfilling and compaction to the Cambridge Water Department for review.

## 1.02 RELATED WORK

A Granular fill materials is included in Section 02230.

## 1.03 REFERENCE STANDARDS

A American Society for Testing and Materials (ASTM)

1. ASTM D1557 - Test Method for Laboratory Compaction Characteristics of Soil Using Modified Effort.

## PART 2: EXECUTION

### 3.01 TRENCH EXCAVATION

A Trench excavation shall include material of every description and of whatever substance encountered including the cement concrete pavement base, except rock and boulders. Pavement shall be cut with a saw, wheel or pneumatic chisel along straight lines before excavating.

B While excavating and backfilling is in progress, traffic shall be maintained, and all utilities and other property protected as provided in the General Conditions and General Requirements.

C Trenches shall be excavated to the depth indicated by the Cambridge Water Department and in widths sufficient for laying the pipe, bracing and for pumping and drainage facilities. The bottom of the excavations shall be firm and dry and in all respects acceptable to the Cambridge Water Department. Trench width shall be practical minimum. Pipeline cover shall be not less than 5 ft. unless otherwise indicated.

D Excavation and dewatering shall be accomplished by methods, which preserve the undisturbed state of sub grade soils. The trench may be excavated by machinery to or just below the designated sub grade, provided that material remaining in the bottom of the trench is no more than slightly disturbed. Sub grade soils, which become soft, loose, "quick", or otherwise unsatisfactory as a result of inadequate excavation, dewatering or other construction methods shall be removed and replaced by screened gravel fill as required by the Cambridge Water Department at the Contractor's expense.

E Clay and organic silt soils are particularly susceptible to disturbance due to construction operations. When excavation is to end in such soils, the Contractor shall use a smooth edge bucket to excavate the last one-foot of depth.

F Where pipe is to be laid directly on the trench bottom, final excavation at the bottom of the trench shall be performed manually, providing a flat bottom true to grade upon undisturbed material. Bell holes shall be made as required.

### 3.02 DISPOSAL OF MATERIALS

A Excavated material shall be stacked without excessive surcharge on the trench bank or obstructing free access to hydrants and gate valves. Inconvenience to traffic and abutters shall be avoided as much as possible. Excavated material shall be segregated for use in backfilling as specified below.

B It is expressly understood that no excavated material shall be removed from the site of the work or disposed of by the Contractor prior to approval from the Cambridge Water Department. When removal of surplus materials has been approved by the Owner, the Contractor shall dispose of such surplus material in areas approved by the Owner.

C Should conditions make it impracticable or unsafe to stack material adjacent to the trench, the material shall be hauled and stored at a location provided by the Contractor. When required, it shall be re-handled and used in backfilling the trench.

### 3.03 SHEETING AND BRACING

A The Contractor shall furnish, put in place and maintain sheeting and bracing required by federal, state or local safety requirements to support the sides of the excavation and prevent loss of ground which could endanger personnel, damage or delay the work or endanger adjacent structures. If the Cambridge Water Department is of the opinion that at any point sufficient or proper supports have not been provided, he may order additional supports placed at the expense of the Contractor. Compliance with such order shall not relieve the Contractor from his

responsibility for the sufficiency of such supports. Care shall be taken to prevent voids outside of the sheeting, but if voids are formed, they shall be immediately filled and rammed.

B When moveable trench bracing such as trench boxes, moveable sheeting, shoring or plates are used to support the sides of the trench, care shall be taken in placing and moving the boxes or supporting bracing to prevent movement of the pipe, or disturbance of the pipe bedding and the screened gravel backfill.

1. When installing ductile iron pipe, trench boxes, moveable sheeting, shoring or plates shall not be allowed to extend below mid-diameter of the pipe. As trench boxes, moveable sheeting, shoring or plates are moved, screened gravel shall be placed to fill any voids created and the screened gravel and backfill shall be re-compacted to provide uniform side support for the pipe.

C The Contractor will be permitted to use steel sheeting in lieu of wood sheeting for the entire job wherever the use of sheeting is necessary. The cost for use of sheeting will be included in the bid items for pipe and shall include full compensation for driving, bracing and later removal of sheeting.

D All sheeting and bracing shall be carefully removed in such manner as not to endanger the construction of other structures, utilities, or property, whether public or private. All voids left after withdrawal of sheeting shall be immediately refilled with sand by ramming with tools especially adapted to that purpose, by watering or otherwise as directed.

### 3.04 TEST PITS

A The Contractor may be required to excavate test pits for the purpose of locating underground utilities or structures as an aid in establishing the precise location of new work.

B Test pits shall be backfilled as soon as the desired information has been obtained. The backfilled surface shall be maintained in a satisfactory condition for travel until resurfaced as specified.

### 3.05 EXCAVATION BELOW GRADE AND REFILL

A Whatever the nature of unstable material encountered or the groundwater conditions, trench drainage shall be complete and effective.

B If the Contractor excavates below grade through error or for his own convenience, or through failure to properly dewater the trench, or disturbs the sub grade before dewatering is sufficiently complete, he may be directed by the Cambridge Water Department to excavate below grade as set forth in the following paragraph, in which case the work of excavating below grade and furnishing and placing the refill shall be performed at his own expense.

C If the material at the level of trench bottom consists of fine sand, sand and silt or soft earth which may work into the screened gravel notwithstanding effective drainage, the sub grade material shall be removed to the extent directed and the excavation refilled with a 6-in layer of coarse sand, or a mixture graded from coarse sand to the fine pea stone, as approved by the Cambridge Water Department, to form a filter layer preserving the voids in the gravel bed of the

pipe. The composition and gradation of gravel shall be approved by the Cambridge Water Department prior to placement. Screened gravel shall then be placed in 6-in. layers thoroughly compacted up to the normal grade of the pipe. If directed by the Cambridge Water Department, bank-run gravel shall be used for refill of excavation below grade.

### 3.06 BACKFILLING

A As soon as practicable after the pipe has been laid and jointed, and tested (if required), backfilling shall begin and thereafter be prosecuted expeditiously. Selected common fill shall be placed around the pipe and hand tamped in layers 6-in thick after compaction. Backfilling shall proceed in this manner to a depth of one (1) foot over the top of the pipe.

B The trench, up to a depth of one (1) foot below the bottom of the specified permanent paving, shall be backfilled with common fill material in layers not to exceed 8-in and thoroughly compacted. The sub base layer for paving shall be of bank-run gravel thoroughly compacted in 6-in layers.

C To prevent longitudinal movement of the pipe, dumping backfill material into the trench and then spreading will not be permitted until selected material has been placed and compacted to a level 1-ft over the pipe.

D Backfill shall be brought up evenly on all sides. Each layer of backfill material shall be thoroughly compacted by rolling, tamping, or vibrating with mechanical compacting equipment or hand tamping, to 95 percent compaction. If rolling is employed, it shall be by use of a suitable roller or tractor, being careful to compact the fill throughout the full width of the trench.

E Bituminous paving shall not be placed in backfilling. Frozen material shall not be used under any circumstances.

IAll road surfaces shall be broomed and hose-cleaned immediately after backfilling. Dust control measures shall be employed at all times.

### 3.07 SOIL-TESTING FOR COMPACTION

A The Cambridge Water Department may select areas within the limits of the fill for testing the degree of compaction to determine conformance to the specifications. Compaction shall be measured as percent density as determined by ASTM D1557, Method D.

B Payment for testing shall be made by the Cambridge Water Department. If test results are unsatisfactory, all costs involved in correcting deficiencies to the satisfaction of the Cambridge Water Department, shall be borne by the Contractor.

### 3.08 RESTORING TRENCH SURFACE

A Where the trench occurs adjacent to paved streets, in shoulders, sidewalks, or in cross-country areas, the Contractor shall thoroughly consolidate the backfill and shall maintain the surface as the work progresses. If settlement takes place, he shall immediately deposit additional fill to restore the level of the ground.

B The surface of any driveway or any other area which is disturbed by the trench excavation and which is not a part of the paved road shall be restored by the Contractor to a condition at least equal to that existing before work began.

### 3.09 PROTECTION

A Curbing and fencing in the vicinity of the Contractor's operations shall be adequately protected, and if necessary removed and restored after backfilling. All curbing and fencing, which are damaged during construction, shall be replaced with material fully equal to that existing prior to construction.

## GRANULAR FILL MATERIALS

### PART 1: GENERAL

#### 1.01 DESCRIPTION

A Granular fill materials are specified in this Section, but their use for bedding pipe, replacement of unsuitable material, gravel cushion in ledge excavation, pavement base, foundation support and similar uses are specified in detail elsewhere. The Cambridge Water Department may order the use of fill materials for purposes other than those specified in other Sections if, in his opinion, such use is advisable.

### PART 2: PRODUCTS

#### 2.01 MATERIALS

Bank run gravel shall consist of hard, durable stone and coarse sand, essentially free from frost, frozen lumps, loam and clay, uniformly graded and containing no stone having any dimension greater than 3-in. The grading of sizes and material shall be such that the gravel may be thoroughly consolidated. The grading shall conform to the following requirements:

<u>Sieve</u>	<u>Percent Passing</u>
3/8-in	70 maximum
No. 10	50 maximum
No. 200	5 maximum



B Screened gravel shall consist of hard, durable, particles of proper size and gradation, free from sand, loam, clay, excess fines and deleterious materials. The size of the particles shall be uniformly graded gravel such that not less than 95 percent of the particles will pass a 1/2-in sieve, 40-70 percent will pass the 3/8-in sieve, and not more than 5 percent will pass a No. 4 sieve.

C Common fill shall consist of mineral soil, substantially free of clay, organic material, loam, wood, trash, snow, ice, frozen soil and other objectionable material which may be compressible, or which cannot be compacted properly. Common fill shall not contain stones larger than 4-in in any dimension, broken concrete, masonry, rubble, asphalt pavement, or other similar materials. It shall have physical properties, as approved by the Cambridge Water Department such that it can be readily spread and compacted.

D Select common fill shall be as specified above for common fill except that the material shall contain no stones larger than 2-in in its largest dimension.

E Sand shall conform to ASTM C33 for fine aggregate.

F Flowable fill shall be supplied by a ready-mix concrete manufacturer experienced in the design and control of flowable fill mixtures. Final compressive strength of flowable fill shall be less than 100 psi to allow for ease of future excavation while still providing an in place load-bearing capacity of 5 tons per square foot. Design information shall be provided to the Engineer prior to use. Contractor shall wrap the pipe with 9-11 mill thick poly where pipe comes in contact with Flowable fill. Flowable fill shall contain the following:

1. Portland Cement shall meet ASTM C-150.
2. Aggregates shall meet ASTM C-33 and be non-reactive, free of contaminants, and exhibit high flow properties.
3. Mineral admixtures shall be materials used in standard ready-mix concrete production or slag cement and shall meet ASTM specifications. Chemical admixtures shall be liquid or powder materials used in standard ready-mix concrete production or specifically designed admixtures for flowable fill. Flowable fill admixtures shall be high-air generators and shall conform to the specifications of Grace Construction Products, "Darafill" or approved equal. **No fly ash is to be used in the mix.**

END OF SECTION

END OF SECTION

APPENDIX J  
TECHNICAL SPECIFICATIONS

**TECHNICAL SPECIFICATIONS**

**NOTE:** WHERE REFERENCE IS MADE BELOW TO THE “STANDARD SPECIFICATIONS”, THIS SHALL BE CONSTRUED TO MEAN THE LATEST EDITION, INCLUDING STANDARD SPECIAL PROVISIONS AND SUPPLEMENTAL SPECIFICATIONS, OF THE MASSACHUSETTS HIGHWAY DEPARTMENT STANDARD SPECIFICATIONS FOR HIGHWAYS AND BRIDGES (English Units Version).

CONSTRUCTION DETAILS REFERRED TO HEREIN SHALL BE CONSTRUED TO MEAN THE CAMBRIDGE WATER DEPARTMENT CONSTRUCTION AND OPERATING PROCEDURES.

## **PROJECT SPECIFIC EXCAVATION, SOIL BACKFILLS AND OFF SITE BORROW/FILL TESTING REQUIREMENTS**

### **(GENERAL REQUIREMENTS – NO SEPARATE PAYMENT)**

**Contractor shall make the following submittals and perform the following testing program on all onsite soils to be reused as backfill and on all off site borrow soils and material placed on the project. The cost of all submittals and testing stated below shall be incidental to the work and paid for by the Contractor.**

#### **A. Submittals:**

1. Independent Laboratory and Testing Company. Submit 4 weeks prior to start of excavation, evidence that the Laboratory/testing company is:
  - a. accredited by the American Associates of the State Highway and Transportation Officials (AASHTO)
  - b. Has minimum 3 years experience in sampling, testing and analysis of soil and aggregates, and monitoring field compaction operations.
  - c. Able to provide 3 references from previous work.
2. Submit to the Cambridge Water Department (CWD) grain size analysis curve (ASTM D422) and compaction test results (ASTM D1557) for each proposed source of backfill including suitable on-site soil to be reused as backfill, for review two weeks prior to use of the material. Grain size analysis shall indicate that the backfill material conforms to the gradation requirements specified.
3. Contractor shall submit to the CWD, a 10 lb representative sample of from each source of borrow material intended to be used, a minimum 7 days prior to delivery. Any material delivered to the site that is not consistent with the sample provided may be rejected, at no cost to the CWD.
4. Contaminant analysis for off site borrow materials used. Each material imported shall be accompanied by a certification statement and analytical results. At a minimum, the certification shall state that the point of origin and that the material is free of contaminants. The certification shall include representative sample analysis from each point of origin of backfill to be used on the site. The samples shall be analyzed by a certified laboratory for total metals (EPA priority pollutant metals), volatile organic compounds (EPA Method 8270), petroleum hydrocarbons (EPA method 418.1), and Total PCB's and pesticides (EPA Method 8081 and 8082). On site soils designated as suitable for reuse can be reused as backfill without providing certification required above.
5. Contractor shall, in coordination with Soil Management Plan, submit to the CWD an Excavation, Backfilling, and Filling Plan at least 2 weeks prior to earth moving activities. The review will be only for the information of the CWD for an overall understanding of the project sequence and site utilization. The contractor shall remain responsible for the adequacy and safety of the means, methods, and sequencing of construction. The plan shall include but not be limited to the following items:
  - a. Detailed sequence of work.
  - b. General description of construction methods
  - c. Number and location of crews and equipment and manpower to be deployed
  - d. Traffic, bicycle and pedestrian management
  - e. Proposed location of stockpiles
  - f. Proposed locations and sequence of test pitting for soil testing and utility installations prior to the start of water pipe, drain, sewer and utility installations.
  - g. Maintenance and continued operation of existing infrastructure.

#### **B. On-site Reuse/Borrow/Fill Testing Requirements**

1. Contractor to perform at his cost, particle size and gradation analyses and compactibility testing in accordance with ASTM D422 and D1557, respectively, minimum one per source

and one for every additional 400 cubic yards of soil/borrow material to be reused/placed. All results to be forwarded to the CWD for review prior to commencing use.

2. Contractor to perform at his cost, in-place field testing for density and moisture content in accordance with ASTM D1156, D2167 or D2922 and ASTM D3017, D4944 or D4949, respectively. CWD shall have access to results during measurements. All results to be submitted to the CWD. Minimum test frequency shall be as follows, and no less than one test per lift or as requested by the CWD:
  - a. Trenches under structures, utilities, roadways, driveways, sidewalks, and bike lanes: Every 100 lin. Ft per lift.
  - b. Trenches not under structures, roads, etc, such as landscape areas: Every 150 lin. Ft per lift.
  - c. Paved roadways or general areas backfilled: Every 1000 sq. ft. per lift
  - d. Under and around structures: Every 500 sq. ft. per lift.

C. Fill/Backfill Placement and Compaction

1. All materials shall be placed in layers not to exceed 8 inches, as placed, and compacted with suitable vibratory compaction equipment to at least 95 percent of the maximum dry density as determined by ASTM D1557. Lift thickness shall be reduced to 4 inches in confined areas only accessible by hand guided compaction equipment.

Any streetcar track encountered shall be removed where directed. Track, as called for in this item, shall consist of the pair of parallel streetcar rails, ties, track and fastenings, frogs, switches and any other appurtenances that could be considered part of the track system.

The Contractor shall exercise special care when excavating near trees. When major roots are in the way, the Contractor shall go under or between them. In no case shall the Contractor disturb the root structure of the trees without direction from the City Arborist. Exposed roots shall be covered promptly. See Item 102.50 Tree Protection and Maintenance for more information.

The Contractor shall perform work in such a manner to minimize dust and utilize dust control techniques when necessary or as directed by the Engineer.

De-watering (pumping) may be required during trench excavation and the prosecution of the work. The Contractor shall obtain a dewatering permit from the City, United States EPA, and Massachusetts Water Resources Authority, prior to beginning construction. Water shall be discharged to a location accepted in advance by the Engineer.

All trench excavations shall strictly adhere to the latest OSHA requirements. Temporary trench support, in compliance with OSHA, required to excavate to a depth to prosecute the work shall along with the proper support of all existing utilities be the responsibility of the Contractor.

## GENERAL

- A. It is the objective of soil/fill management practices specified here to handle all soil/fill excavated from the site during the course of this contract in a cost-effective manner and in accordance with applicable state and federal regulations. The Contractor shall reuse excavated materials, as approved by the CWD, prior to using imported fill in order to reduce the volume of material to be disposed off-site provided the material is geotechnically suitable as backfill and does not result in spreading contamination to other areas or other soil/fill strata. Excavated soil/fill, which is displaced by design features, (e.g. pipe and manholes), may be used as backfill elsewhere on the project provided the soil/fill is geotechnically suitable and does not result in spreading contamination or degrading the environmental quality at the location of reuse. Imported backfill shall be used only as accepted by the Engineer.
- B. The Contractor shall be responsible for coordinating waste disposal, and as such, shall be responsible for identifying an appropriate facility which can receive the material and, if necessary, collect additional characterization samples to satisfy local, state, and federal regulations as well as the Contractor's selected disposal facility's acceptance criteria.
- C. Unless specifically stated otherwise, terms used in this specification are as defined in the MCP, 310 CMR 40.0006.
- D. Any soils which contain exhibit petroleum or chemical odor or visual indications of oil or hazardous materials shall be handled as potentially contaminated soils. Soil which does not have any evidence of contamination can be reused within the *area of excavation*. Soil/fill which is staged and characterized can be reused within the *area of excavation* or elsewhere on site provided the material has equal or less contamination than the point where it is to be reused.
- E. Contaminated soil/fill (including petroleum-contaminated soil/fill) which cannot be reused on site shall be reused off-site, recycled, or disposed as a solid waste at an appropriately permitted facility unless it also meets the regulatory definition of hazardous waste as defined in 40 CFR part 261 or contains PCBs or asbestos.
- F. Notification Procedures:

In the event of an emergency, the Contractor shall contact the following entities at the earliest possible opportunity:

- 1. Owner's designated representatives.
- 2. City of Cambridge DPW
- 3. City of Cambridge Fire Department
- 4. Engineer
- 5. Massachusetts DEP.
- 6. CWD

The Contractor shall prepare in advance of work activities a notification list, complete with phone numbers, addresses, and contact names for all parties to be notified (including, but not limited to, the parties listed above) in the event of an emergency.

- G. The Contractor shall provide the following at least two weeks prior to mobilizing onto the site:

- 1. Soil and Waste Management Plan (SWMP):

The SWMP shall outline measures for sampling, analysis, disposal, and shall identify a waste staging area in the event that soil is stockpiled for subsequent reuse and/or disposal or unknown materials are encountered. The SWMP shall outline procedures for securing the staging area, controlling dust and soil / fill migration, appropriate covering of stockpiles to ensure adequate wind protection and keeping the soil dry. The Contractor is advised that no City-owned or controlled areas are available to serve as waste staging

areas for this Project. The Contractor may opt to precharacterize anticipated geotechnically unsuitable soils for load and go disposal. The Contractor's procedures shall be described in the Soil and Waste Management Plan.

2. Health and Safety Plan (HASP):

The Health and Safety Plan shall outline measures for encountering oil and hazardous material (OHM), including exposure monitoring, prevention methods, and emergency response procedures.

3. Contingency Management Plan (CMP):

The CMP shall provide details on construction methods, and site location and availability of the staging area(s) for approval by the CWD and/or their representative.

4. Spill and Discharge Control Plan (SDCP):

This SDCP shall provide contingency measures and reporting responsibilities for potential uncontrolled spills and discharges of contaminated and/or hazardous materials, including, but not limited to, leachate, decontamination water, sewage, and other on-site waste materials.

5. Dust, Vapor, and Odor Control Plan (DVOCP):

The DVOCP shall include measures to control objectionable dust, vapors, and odors originating from the site. The DVOCP shall describe procedures to minimize the creation of dust, and the control of objectionable vapors and odors originating from the site.

**DISPOSAL OF SOIL – BACKGROUND SOILS (CLASS A-1)**

GENERAL:

Background Conditions (Class A-1): Background is defined in 310 CMR 40.0006 as those levels of oil and hazardous material that would exist in the absence of the disposal site of concern which are either:

- a. *ubiquitous and consistently present in the environment at and in the vicinity of the disposal site of concern; and attributable to geologic or ecologic conditions, or atmospheric deposition of industrial process or engine emissions;*
- b. attributable to coal ash or wood ash associated with fill material;
- c. releases to groundwater from a public water supply system;
- d. petroleum residues that are incidental to the normal operation of motor vehicles.

Any soil or fill material which meets the regulatory definition of "background" as defined in 310 CMR 40.0006 may be reused as common fill/ordinary borrow.

For record keeping purposes soil/fill that meet the definition of background, shall be transported under a Material Shipping Record.

**DISPOSAL OF SOIL – IMPACTED <RCS-1 (CLASS A-2)**

GENERAL:

Impacted <RCS-1 Soil/Fill (Class A-2): Any soil or fill material which contains oil or hazardous materials (OHM) at concentrations greater than background levels but less than release notification thresholds established by 310 CMR 40.0300 and 40.1600. Impacted soil may be reused at the *area of excavation* or as fill provided it is reused in an area of equal or greater contamination.

For record keeping purposes soil/fill that meets the definition of impacted soil/fill and does not meet the definition of contaminated soil/fill or remediation waste, shall be transported under a Material Shipping Record.

**DISPOSAL OF SOIL – DAILY COVER UNLINED  
LANDFILL (CLASS B-1)**

GENERAL:

Contaminated Soil/Fill (Class B): Any soil or fill material which contains oil or hazardous materials at concentrations equal to or greater than a release notification threshold established by 310 CMR 40.0300 and 40.1600, except where the presence of the material is consistent with the regulatory definition of "background" as defined in 310 CMR 40.0006.

Class B-1: Soil and Fill that meet all applicable criteria (i.e., COMM 97-001 and/or facility-specific permit requirements) for reuse as daily cover, intermediate cover, or pre-cap contouring material at in-state unlined landfills.

**DISPOSAL OF SOIL – DAILY COVER LINED  
LANDFILL (CLASS B-2)**

GENERAL:

Contaminated Soil/Fill (Class B): Any soil or fill material which contains oil or hazardous materials at concentrations equal to or greater than a release notification threshold established by 310 CMR 40.0300 and 40.1600, except where the presence of the material is consistent with the regulatory definition of "background" as defined in 310 CMR 40.0006.

Class B-2: Soil and Fill that meet all applicable criteria (i.e., COMM 97-001 and/or facility-specific permit requirements) for reuse as daily cover, intermediate cover, or pre-cap contouring material at in-state lined landfills.



**DISPOSAL OF SOIL – NON-HAZARDOUS SOLID WASTE  
(CLASS B-3, B-4, B-5 AND B-6)**

GENERAL:

Probable Class B-3 through B-6 Material: Soil/Fill suspected of having high levels of contamination (i.e., equal to or greater than the applicable reportable concentration but suitable for disposal at a licensed non-hazardous solid waste facility). Soil with jar headspace results greater than 100 ppm or soil containing significant visual (i.e. >10% foreign material by volume) or strong olfactory evidence of contaminants. This material is to be sampled separately due to the potential of exceeding DEP’s guidelines for reuse as daily cover at a landfill and requiring either recycling at an asphalt batch plant or as solid waste at an appropriately permitted disposal facility. The analytical results shall determine the final reuse/disposal option.

**DISPOSAL OF SOIL – RCRA HAZARDOUS WASTE  
(CLASS C-1 AND C-2)**

GENERAL:

Probable Class C Material: Soil/Fill suspected of being a hazardous waste as defined by the Resource Conservation and Recovery Act or the Toxic Substances and Control Act. Material with visually gross levels of contamination, including free product or containing evidence of hazardous constituents including but not limited to indications of tannery wastes or coal tar or any other waste which may contain elevated levels of pollutants, shall be placed in this category. This material is to be sampled separately due to the potential of exceeding RCRA or TSCA hazardous waste thresholds requiring disposal at an appropriately permitted hazardous waste facility.

**DISPOSAL OF ASBESTOS WASTE**

GENERAL

Probable Asbestos Containing Material: Soil/Fill suspected of containing asbestos as evidenced by the presence of suspect asbestos-containing building debris such as cementitious piping, vinyl floor tiling, roofing paper or paper-like insulation materials or any other suspect asbestos containing material observed in the soil/fill.

**WATER SYSTEMS**

GENERAL

Work under this section shall consist of making alterations and improvements to the existing municipal water system or constructing new sections of water mains. This work includes furnishing all labor, equipment, materials, tools and incidentals required for the installation, cleaning, testing and disinfection of new pipe, fittings, valves, hydrants, service connections and appurtenances; abandoning existing water pipes by cutting and capping; removing existing valve boxes; and removing sections of existing water mains, including valves, fittings and hydrants, to complete connections to the new water pipes as shown on the Drawings and in accordance with these Specifications. The new piping system shall meet the minimum requirements of and be subject to the approval of the Cambridge Water Department (CWD). All connections to the existing water system must be approved by the CWD. All public water mains, hydrants, valves and appurtenances located within public ways, city-owned easements and private ways open to public travel within the City of Cambridge are owned and under the jurisdiction of the CWD.

Where reference herein is made to a standard, the revision in effect at the time of the bid opening shall apply. Work to be done under this section for water system improvements shall conform to all of the relevant requirements of the Cambridge Water Department (CWD), American Water Works Association (AWWA), American National Standards Institute (ANSI), American Society for Testing and Materials (ASTM), National Sanitation Foundation (NSF) 61 Standards for Drinking Water System Components Health Effects and Underwriters Laboratories (UL). The Commonwealth of Massachusetts Department of Environmental Protection (DEP) “Guidelines and Policies for Public Water Systems” and the Commonwealth of Massachusetts Drinking Water Regulations: 310 CMR Section 22 shall be adhered to. All materials for the construction of water system improvements shall be new, in perfect

working condition and be of the type as specified herein and as currently used by the CWD. Copies of the CWD's Construction and Operating Procedures can be obtained by contacting the Cambridge Water Department, during normal business hours Monday through Thursday 8:30 AM to 5:00 PM and Friday 8:30 AM to 12:00 PM, at 250 Fresh Pond Parkway, Cambridge, MA 02138 or at 617-349-4770. Contractor must submit a Water Works Construction Permit with the CWD prior to commencing work. Copies of this permit can be obtained by contacting the CWD during normal business hours.

Work and compensation under this section involves alterations and improvements to the municipal water system and temporary repair of all traveled ways. Final roadway improvements shall be performed and paid for in accordance with the portion of this Contract designated for such roadway improvements. All related construction work for water system alterations and improvements (control of work; environmental protection; dust control; traffic regulation; policing; control of materials; dewatering and drainage; rock and boulder excavation; reinforced concrete subbase removal; trenching, backfilling and compaction; granular materials; erosion and sedimentation control; temporary pavement repair and resurfacing; decking; concrete and controlled density fill (CDF); loaming and seeding; miscellaneous work; etc.) not specifically described herein shall be in accordance with the Massachusetts Highway Department Standard Specifications for Highways and Bridges (English Units Version), including Standard Special Provisions and Supplemental Specifications (English Units Version). Where reference is made herein to the "Standard Specifications," this shall be construed to mean the latest edition, including Standard Provisions and Supplemental Specifications, of the Massachusetts Highway Department Standard Specifications for Highways and Bridges (English Units Version). Construction information and details referred to herein shall be construed to mean the Cambridge Water Department's (CWD) Standard Construction and Operating Procedures.

The CWD will be responsible for operation of any existing hydrants, valves, curb stops, corporation stops, service connections or other existing water system appurtenance unless the Contractor is otherwise directed by the CWD. The Contractor shall not draw any water from the existing distribution system without specific approval of the CWD. The CWD will provide a source of supply from the existing treated water distribution system for Contractor's use in filling and flushing water mains and for other construction purposes. Contractor must apply for temporary water use through the required CWD permits, including CWD cross-connection and backflow prevention requirements. Contractor shall maintain an air break at all times between the CWD's existing water distribution system and the Contractor's equipment to prevent cross-connection. The Contractor shall provide a suitable means of backflow prevention to prevent cross-connection. The means and methods for backflow prevention are subject to the review and approval by the CWD. Contractor shall provide accurate means (i.e., meters) for measuring the quantity of all water used for construction purposes, flushing and filling water mains, pressure/leakage tests, disinfection of water mains and for other purposes for the CWD's annual estimates of non-revenue water. Contractor shall submit to the CWD evidence of calibration for the equipment used to measure all water used for construction purposes. The Contractor shall not knowingly allow water to leak or run to unnecessary waste. The CWD reserves the right to limit the maximum quantity of water provided to the Contractor at no cost for construction purposes. Additional water required by the Contractor will be provided by the CWD at standard billing rates for the volume required.

Contractor shall submit to the CWD for review shop drawings including, product data, design calculations, catalog cuts, drawings, operations and maintenance manuals, warranty information, certified test reports and affidavits, name of material suppliers and handling procedures to ensure that all materials have been manufactured and tested in accordance with the required standards and Specifications. CWD reserves the right to request additional information from Contractor to ensure that the materials used are in accordance with the required Specifications.

Water pipes, fittings, valves, hydrants, service connections and appurtenances shall be located substantially as shown on the Drawings. The Engineer and CWD reserves the right to make such modifications in locations as may be found desirable to avoid interference between pipes or for other reasons. Pipe fitting notation is for the Contractor's convenience and does not relieve Contractor from installing and jointing different or additional items as required for completion of the piping system. All connections to the existing water system must be approved by the CWD. No electrical grounds shall be made on water mains or service pipes per the CWD.

## **PROTECTION OF UNDERGROUND STRUCTURES**

All conduits, pipes or structures uncovered during excavation, whether or not they are shown on the Drawings, shall be protected, and if damaged by the Contractor, shall be repaired by him/her or the utility company at the expense of the Contractor. The Contractor shall not abandon existing conduits, pipes or structures without the prior approval of the Engineer, CWD or Cambridge Department of Public Works (DPW).

Written notice of at least 7 days shall be given to the CWD, before any construction is started and before any water main is shut off, so as to provide opportunity for the CWD to exercise valves. Prior written notice of at least 72 hours shall be given by the Contractor to the CWD, Cambridge DPW, Cambridge Fire Department (CFD), Cambridge Police Department, and impacted abutters with a copy of such notice submitted to the Engineer, before any construction is started and before any water main is shut off. In no case shall a valve or hydrant be opened or shut without proper authorization from the CWD.

When any existing water main is shut down or otherwise taken out of service to facilitate construction of this work, Contractor shall cover the existing fire hydrants taken out of service with bags clearly labeled "Not In Service" or "Out Of Service." Bags used to cover hydrants must be clearly marked as such to alert the Fire Department that existing hydrants are out of service. Contractor must notify the CWD and CFD of all existing hydrants taken out of service.

The CWD reserves the right to limit the amount of existing water mains and hydrants that may be offline or out of service at any time during construction.

#### **MATERIALS – GENERAL**

All materials for water system components shall be new and of the type as specified and as currently used by the CWD as specified herein. Soil and borrow, aggregate, bituminous and cement concrete materials and other related items not specifically described herein shall meet the requirements specified in the Massachusetts Highway Department Standard Specifications for Highways and Bridges (English Units Version), including Standard Special Provisions and Supplemental Specifications (English Units Version).

#### **CONSTRUCTION METHODS – GENERAL**

Unless otherwise specified herein, construction methods for water system improvements shall be in accordance with the Massachusetts Highway Department Standard Specifications for Highways and Bridges (English Units Version), including Standard Special Provisions and Supplemental Specifications (English Units Version).

Contractor shall excavate trenches using excavation support systems as required and in accordance with all Federal, State and local regulations. Undermining of existing foundations must not occur. Excavations should not extend into the zone of influence of any existing structures. The zone of influence is defined as the line extending 2 feet beyond the edge of the foundation of any existing structure, then outward and downward at a slope of 1 horizontal to 1 vertical. If open excavations are feasible, the side slopes should be designed and sloped in accordance with OSHA regulations.

Where subgrade materials consist of granular soils (sand and gravel), the subgrade shall be proof-rolled with a minimum of 2 passes of an approved hand operated vibratory compactor. If organic soils or loose or disturbed soils are encountered at the subgrade level, the unsuitable soils shall be removed up to a maximum of 4 feet below the pipe invert and backfilled with screened gravel. Where excavations end in clay, silt, fine sand, Contractor shall use a smooth edge bucket to excavate the last 1 foot of depth. As shown on the Drawings, unsuitable organic soil is encountered in the subgrade between borings B-6A and B-6C. To limit the potential settlement of the new pipes and services between B-6A and B-6C, the Contractor shall over excavate the trench to a depth of 4 feet below the pipe invert and remove and replace the unsuitable material with compacted screened gravel as specified herein.

Where excavations extend below existing groundwater levels, the Contractor is required to design, furnish, install, operate, monitor, and maintain a dewatering system that maintains a dry, undisturbed subgrade until construction has been completed to such an extent that pipelines and fill will not be floated or otherwise damaged. The

Contractor shall furnish the necessary pumps, tools and equipment to handle any water encountered in the pipe trenches, and shall maintain the trench in satisfactory condition and free from water during the laying of the pipe. Dewatering shall at all times be conducted in such a manner as to preserve the natural undisturbed condition of the subgrade soils at the proposed bottom of excavation. Groundwater control system components shall be located where they will not interfere with construction activities adjacent to the work area.

To avoid disturbance to the subgrade, the groundwater elevation shall be maintained at least 2 feet below the subgrade level during the entire period of excavation so as to provide a dry, stable subgrade and to permit construction to proceed in-the-dry. Where the phrase "in-the-dry" is used herein, it shall be defined as an excavation subgrade where the groundwater level has been lowered to at least 2 feet below the lowest level of the excavation, is stable with no ponded water, mud, or muck, is able to support construction equipment without rutting or disturbance and is suitable for the placement and compaction of fill material, pipe or cementitious materials. Additional groundwater lowering may be necessary, depending on construction methods and equipment used and the prevailing groundwater and soil conditions. The Contractor is responsible for lowering the groundwater as necessary to complete construction in accordance with the plans and specifications at no additional cost to the CWD. The Contractor should be prepared to predrain the soil prior to excavation using a system of sumps, wells, and/or well points designed by a professional engineer registered in the Commonwealth of Massachusetts.

The Contractor shall also provide surface water control and shall collect and properly dispose of all discharge water from the dewatering and drainage systems. New pipe, after being laid, shall not under any circumstance be used as a drain pipe for the trench. Under no circumstances shall water from dewatering systems be discharged into the existing or new sanitary sewer systems. Pumping from dewatering systems shall be continuous until trenches are adequately backfilled. Dewatering units used in the work shall be surrounded by suitable filter sand and no fines shall be removed by pumping. Standby pumping systems and a source of standby power shall be maintained at all sites.

If wet weather is encountered during construction, the Contractor should take care to schedule excavations to limit the duration of open cuts, slope the bottoms of the excavations to facilitate drainage and provide berms to limit runoff into the excavations. In addition, excavated material to be reused as fill should be stockpiled in such a manner that promotes runoff and limits saturation of the materials.

Contractor shall perform all dewatering and drainage work in accordance with current applicable regulations and codes of all Federal, State and local agencies. All dewatering and drainage work shall be done in a manner which will protect adjacent structures and utilities and shall not cause loss of ground or disturbance to the pipe bearing soils or to soils which support overlying or adjacent structures. Contractor shall dewater and excavate, at all times, in a manner which does not cause loss of ground or disturbance to the pipe bearing soil or soil which supports overlying or adjacent structures. If the subgrade of the trench or excavation bottom becomes disturbed due to inadequate dewatering or drainage, Contractor shall excavate below normal grade as directed by the Engineer or CWD and refill with screened gravel or other material as approved by the Engineer at the Contractor's expense.

Prior to construction, the Contractor shall submit a dewatering and drainage system design plan prepared by a professional engineer registered in the Commonwealth of Massachusetts. The plan shall include a description of the proposed dewatering system and include the proposed installation methods to be used for dewatering and drainage system elements. The plan shall include equipment, materials, methods, and techniques for the proposed dewatering and drainage. Include the dewatering system design calculations in the plan. The plan shall identify the anticipated area influenced by the dewatering systems and address impacts to adjacent existing and proposed structures. Contractor shall not proceed with any excavation or dewatering activities until the dewatering submittals has been reviewed, approved, and accepted by the Engineer and CWD. Design review and field monitoring activities by the CWD or by the Engineer shall not relieve the Contractor of his/her responsibilities for the work. Contractor shall also prepare and obtain all dewatering permits required by the Massachusetts Department of Environmental Protection (MADEP) and the City of Cambridge.

At the completion of excavation, backfilling and compaction work, and when approved by the Engineer, all dewatering and drainage equipment used for the groundwater and surface water control systems shall be removed from the site. All areas disturbed by the installation and removal of groundwater control systems and observation wells shall be restored to their original condition. If in the opinion of the CWD removing any equipment would

result in ground movements causing adverse settlement to adjacent ground surfaces, utilities or existing structures, these systems shall be left in place.

All work associated with designing, permitting, furnishing, installing, operating, monitoring, maintaining dewatering systems throughout the construction period, repairing damage (damage to properties, buildings or structures, utility installations, pavements, etc.) caused by dewatering and drainage system operations, and removing equipment will be considered incidental to pipe items and will not be measured separately for payment.

New pipes should be placed on a bedding of at least 12 inches of screened gravel (as specified herein) below their invert. Where trench excavations extend below the groundwater level, a filter fabric should be placed between the prepared soil subgrade and the screened gravel to prevent the fines from migrating into the pipe bedding material. Pipes should be backfilled to the springline of the pipe with screened gravel. Filter fabric should be Mirafi, Type 140N; Dupont, Type PAR, Style 3401, or equal.

Screened gravel shall be in accordance with the relevant provisions and requirements of the Massachusetts Highway Department Standard Specifications for Highways and Bridges (English Units Version), including Standard Special Provisions and Supplemental Specifications (English Units Version) and shall be graded within the following limits:

<u>Sieve Size</u>	<u>Percent Finer by Weight</u>
5/8 in	100
1/2 in	40 to 100
3/8 in	15 to 45
No. 10	0 to 5

Trenches shall be backfilled using select common fill as specified herein (i.e. contain stones no larger than 2 inches) and be compacted to at least 95 percent of the maximum dry density as determined by laboratory test ASTM D1557. To limit the potential for uneven settlement along the saw-cut roadway due to the water main and service laterals, the top 2 feet of all lateral trenches shall be backfilled with cementitious flowable fill (controlled density fill) as specified herein. Trench details are shown on the Drawings.

Select common fill for trench backfill should consist of granular soil substantially free of clay, organic material, loam, wood, trash, snow, ice, frozen soil and other objectionable material which may be compressible, or which cannot be compacted properly. It should contain stones no larger than 2 inches and have no more than 30 percent of material passing the No. 200 sieve. It shall not contain broken concrete, masonry, rubble, asphalt pavement, or other similar materials. It shall have physical properties, as approved by the Engineer, such that it can be readily spread and compacted. Select common fill should be placed in layers not to exceed 8 inches, as placed, and compacted with suitable vibratory compaction equipment to at least 95 percent of maximum dry density as determined by ASTM D1557. Lift thickness should be reduced to 4 inches in confined areas accessible only to hand guided compaction equipment. Existing subgrade material excavated from the trench may be reused as select common fill for trench backfill, provided it meets these requirements and can be properly compacted to at least 95 percent of maximum dry density as determined by ASTM D1557. Any existing subgrade material removed from the trench that does not meet these requirements shall be removed from the site and replaced with suitable select common fill backfill material, compacted as specified. Care should be taken to separate topsoil and organic soil layers from trench material proposed for reuse as select common fill. Compaction testing is required to show that the required 95 percent compaction has been achieved. Compaction testing will be considered incidental to the pipe items and will not be measured separately for payment.

### **Materials**

Ductile iron water pipe of the size specified shall conform to AWWA C150 and C151 and shall be Class 52, double cement lined and tar coated. Ductile iron pipe shall have an interior cement mortar lining in accordance with AWWA C104 double thickness. Buried pipe shall be installed with a bituminous coating in accordance with AWWA C151. Pipe shall be supplied in standard lengths as much as possible. Ductile iron water pipe shall be as manufactured by U.S. Pipe and Foundry, Griffin Pipe Products or approved equal who is a member of the Ductile Iron Pipe Research Association (DIPRA). All ductile iron water pipe for this project shall be supplied by a single manufacturer.

Pipe fittings shall be ductile iron with a pressure rating of 350 psi for 24 inch and smaller piping and 250 psi for 30 inch and larger piping. Fittings shall meet the requirements of AWWA C110 or AWWA C153 as applicable. Fittings shall have the same pressure rating, as a minimum, of the connecting pipe. All ductile iron fittings shall be cement lined. Ductile iron fittings shall have an interior cement mortar lining in accordance with AWWA C104 double thickness. Buried fittings shall be installed with a bituminous coating in accordance with AWWA C110. Fittings are required to be equipped with a mechanical joint restraint as specified herein. Mechanical joint fittings shall be ductile iron compact fittings per AWWA C153, wherever compact fittings are available, and be rated for a 350 psi working pressure. All nuts and bolts for fittings shall be of a type equal to ductile iron or KOR-10 steel T-bolts and nuts. All ductile iron fittings for this project shall be supplied by a single manufacturer. Hydrant tees shall be of the anchor type, as described in the item for hydrants. The branch of the anchoring tees shall have a plain end with an integral gland and rotating mechanical joint restraints. Mechanical joint restraint to provide a restrained connection with thrust blocks as required.

Closures shall be made with mechanical joint solid sleeves or coupling systems and shall be located in straight runs of pipe outside the limits of restrained joint systems. Location and types of closures shall be subject to the approval of the CWD. Sleeve type couplings shall be Smith Blair Style 441, Dresser Style 253 or 360, Romac Style 501 or approved equal. Couplings shall be provided with plain, Grade 27, rubber gaskets and with black steel, track-head bolts with nuts. Buried sleeve-type couplings shall have a protective wrapping of "Denso" material by Denso Inc. of Texas or equal. Where "Denso" material is used, the joint shall be packed up with "Densyl mastic" to give an even contour for wrapping with "Densopol" tape. A 1.5 mm thick coating of "Denso" paste shall be applied followed by 100 mm or more wide "Densopol" tape wound spirally round the joint with at least 50 percent overlap.

The ductile iron pipe and fittings manufacturer must have experience with successful fabrication of ductile iron pipe to AWWA C151 standards of the largest specified type and diameter or larger ductile iron pipe with similar coatings/linings within the past five years, and this experience shall include the successful fabrication of at least 50 fittings in compliance with AWWA C110 or C153 of the largest specified diameter or larger with similar coatings/linings. All ductile iron pipe and fittings shall be manufactured in the United States. All ductile iron pipe and fittings shall be marked in accordance with all applicable AWWA standards, including the manufacturer's name, date of fabrication, size, type, class/wall thickness and AWWA standards produced to. Special fittings, bends and appurtenances requiring specific orientation shall be appropriately marked with the words "Top" in the correct position and in a consistent location. Each length of ductile iron pipe supplied shall be hydrostatically tested at the point of manufacturer in accordance with AWWA C151 and Contractor shall provide certified test results to CWD prior to pipe shipment to the job site. All ductile iron pipes shall be tested and inspected at the manufacturer's facilities prior to shipment. The CWD reserves the right to inspect all ductile iron pipe and fittings after delivery to the job site. Pipe and fittings shall be subject to rejection at any time on account of failure to meet any of the Specification requirements even though the pipe and fittings may have been accepted as satisfactory at the place of manufacture. Pipe and fittings rejected after delivery (including defects from manufacturing or delivery/transport) shall be marked for identification and shall immediately be removed from the job site at the Contractor's expense.

Care shall be taken in loading, transporting and unloading all ductile iron pipe and fittings to prevent damage to the pipe, fittings, coatings and linings. All pipe and fittings shall be handled, shipped, stacked and stored in accordance with AWWA C600. Any damage to ductile iron pipe and fittings discovered during examination on site shall be repaired or the item replaced to the satisfaction of the CWD at the cost of the Contractor, before proceeding with the work. Pipe and materials, if stored on-site, shall be kept safe from damage and the interior surfaces shall be kept free of dirt, excessive corrosion and other foreign matter at all times. Pipe gaskets shall be placed and stored in a cool location out of direct sunlight and shall not come into contact with petroleum products. Gaskets shall be used on a first in, first out basis. Lined and/or coated pipe shall be suitably protected from exposure and heating of the sun at all times. It is the responsibility of the Contractor to ensure that all pipe and fittings are not damaged by handling and on-site storage.

Contractor shall ensure and be responsible that all connections between pipe and fittings are compatible. Ductile iron pipe/fitting joints shall be push-on rubber gasket type or rubber gasket mechanical joint per AWWA C111 in unrestrained areas, except where flanged joints are required. In restrained areas, both pipe and fitting joints shall be push on rubber gasket, locking ring type restrained joints per the manufacturer's standard, except where flange joints

are required. All gasket materials shall comply with Table 5-1 of AWWA M41. Rubber gasket joints shall conform to AWWA C111. Gaskets shall be of styrene butadiene rubber (SBR).

The minimum number of restrained joints required for resisting forces at fittings and valves shall be determined from the length of restrained pipe on each side of the fittings and valves to develop adequate resisting friction with the soil. The required lengths of restrained joints and required concrete thrust block bearing areas and volumes shall be as shown on the Drawings. The CWD requires both restrained joints and thrust blocks be used to adequately resist forces for all fittings and valves.

Restraint for push-on joint pipe shall be positive "Locked-type" joints manufactured by the pipe and fitting manufacturer that utilize restraint independent of the joint gasket. All restrained joints shall be suitable for the required test pressure. Joints shall be fabricated of heavy section ductile iron casting. Bolts and nuts shall be low carbon steel conforming to ASTM A193, Grade B7. Restraint for mechanical joint pipe shall use retainer glands for restraining the joint. MegaLug retainer glands as manufactured by EBBA Iron Inc. of Texas or approved equal shall be used for restraining mechanical joints of ductile iron pipe and fittings. Restrained push-on joints shall be "TR Flex" by U.S. Pipe and Foundry Company, "Snap Lok" by Griffin Pipe Products Company or approved equal. Contractor must submit a laying schedule for proprietary joint restraint systems which do not allow cutting of the pipe in the field. Restrained pipe joints that achieve restraint by incorporating cut out sections in the wall of the pipe shall have a minimum wall thickness at the point of the cut out that corresponds with the minimum specified wall thickness of the rest of the pipe.

For up through 48 inch diameter ductile iron pipe, an alternate restraint system can be incorporated in the design of the follower gland. The gland shall be manufactured of ductile iron conforming to ASTM A536. Dimensions of the gland shall be such that it can be used with the standard mechanical joint bell and tee-headed bolts, as specified with the pipe. The restraint mechanism shall consist of numerous individually activated gripping surfaces to maximize restraint capability. The gripping surfaces shall be wedges designed to spread the bearing surfaces on the pipe. Actuation of the gripping wedges shall be by torque limiting twist-off nuts sized same as T-bolts for mechanical joints. When the nut is sheared off, standard hex nut shall remain. The restraint device shall be capable of full mechanical joint deflection during assembly and the flexibility of the joint shall be maintained after burial. The individual actuated gripping wedges shall increase their resistance to pull-out as pressure or forces increase. The restraint device shall have a working pressure of at least 350 psi for sizes 16 inch and smaller, 250 psi for sizes greater than 16 inches and a minimum safety factor of 2 to 1. Restraint devices shall be listed by Underwriters Laboratories up through 24 inches in size and approved by Factory Mutual up through 12 inches in size. Restraint devices shall be EBAA Iron MegaLug Series 1100 or approved equal. Pipe manufacturer proprietary mechanical joint restraint systems that utilize wedge style gripping systems or a gland/ring positive restraint system will be considered acceptable on a case by case basis. The CWD requires both restrained joints and thrust blocks be used to adequately resist forces at all fittings and valves.

Thrust blocks shall be furnished for all fittings and valves as shown on the Drawings. CWD requires restrained joints be installed in addition to thrust blocks as previously specified. The cement concrete for thrust blocks shall be 3,000 psi, 1-1/2 inch 470 cement concrete per the Massachusetts Highway Department Standard Specifications for Highways and Bridges (English Units Version), including Standard Special Provisions and Supplemental Specifications (English Units Version). Thrust blocks shall be poured against undisturbed ground as shown on the Drawings and shall be so placed so that pipe joints will be accessible for any future repairs.

Threaded ductile iron flanges for ductile iron pipe, if required, shall be fabricated per AWWA C115 and sealed during installation with a special high pressure, full face gasket per AWWA C111. At the pipe manufacturer's option, the use of 250 lb. pattern flanges, which are faced and drilled in accordance with ANSI B16.1 may be substituted in order to match valves or other equipment and/or to meet the required working pressure requirements. All flanges shall be rated for the same pressure as the adjacent pipe in all cases. Compatibility of the flanges with the 250 lb. class and higher special class AWWA valves will be the responsibility of the Contractor. Flanges shall be pre-drilled and then faced after being screwed onto the pipe, with flanges true to 90 degrees of the pipe axis and shall be flush with the end of the pipe. Gaskets shall be full face rubber, 1/8 inch thick SBR material such as American Torseal Gasket or approved equal. Special material ring gaskets such as those by Garlock or equal may be required for pressures exceeding 250 psi for ANSI and custom flanges. Flanged joints shall be supplied with bolts and nuts on one end, bolt studs with a nut at each end, or studs with nuts on one end where the flange is tapped.

The number and size of bolts shall comply with the same standard as the flange. Bolts and nuts shall, except otherwise specified, comply with ASTM A193, Grade B7. Blind flanges shall mate with regular flanges. Filler flanges and beveled flange fillers shall be furnished and drilled complete with extra length bolts.

For other types of couplings and adapters that may be required, split sleeve type flexible couplings shall be Victaulic Depend-O-Lok Style E x E (unrestrained) or F x F (self-restrained) or equal. Grooved flexible joints for ductile iron pipe sizes 36 inch and smaller must be in accordance with AWWA C606 and shall be Victaulic Style 31 or equal. Shouldered flexible joints for ductile iron pipe larger than 36 inch shall be Victaulic Style 44 or equal. A minimum of Class 53 ductile-iron pipe must be used for pipes with Victaulic couplings.

### **Construction Methods**

Ductile iron pipe and fittings shall be shipped, handled, stored and installed in accordance with AWWA C600 and the manufacturer's instructions. If any damaged pipe or fitting is discovered after it has been laid, it shall be removed and replaced with a sound pipe or fitting at the Contractor's expense. All pipe and fittings shall be thoroughly cleaned before laying, shall be kept clean and free of dirt and all foreign matter until they are used in the work and when installed or laid and shall conform to the lines and grades shown on the Drawings.

The minimum bury depth for new water mains and service pipe is 5 feet to a maximum of 7 feet, unless otherwise approved by the CWD. All water pipe shall be laid in a trench separate from any other utility. The horizontal distance between water mains or service pipe and any other utility shall be at minimum no less than 3 feet and the vertical distance shall not be less than 1 foot. The horizontal distance between water mains or service pipe and all sanitary sewers shall be at least 10 feet and the vertical distance between water mains or service pipe and all sanitary sewers shall be at least 18 inches per Massachusetts Department of Environmental Protection "Guidelines and Policies for Public Water Systems". When the vertical distance between water mains cannot be maintained at least 18 inches above the top of any sanitary sewer, or a new water main must cross under a sewer, the water main shall be constructed with mechanical joint pipe based on water-tightness and structural soundness and one full length of the new ductile iron water pipe shall be centered about the sewer crossing so that the water main joints will be as far away from the sewer as possible. All water mains and service pipe that cross under sanitary sewers must be "control density filled (CDF)" or concrete encased as shown on the Drawings.

All ductile iron pipe and fittings shall be installed in accordance with the requirements of AWWA C600. The proper tools and equipment for the safe and convenient handling and laying of pipe shall be used. A firm, even bearing throughout the length of the pipe shall be provided by digging bell holes at each joint and by tamping backfill materials at the side of the pipe to the spring line. Blocking will not be permitted. The pipe interior shall be maintained dry and broom clean throughout the construction period. When pipe installation is not in progress, open ends of the pipe shall be closed by a watertight plug or other approved means. Sufficient backfill shall be placed to prevent flotation. The deflection at joints shall not exceed that recommended by the manufacturer. Contractor shall furnish the necessary pumps and tools to handle any water encountered in the pipe trench, and shall maintain the trench in satisfactory condition and free from water when laying the pipe. Where required, Contractor shall provide suitable bridges for traffic to cross open trenches at streets and driveways.

When field cutting the pipe is required, the cutting shall be done by machine, leaving a smooth cut at right angles to the axis of the pipe. The end of the cut pipe shall be beveled to conform to the manufacturer's recommendations for the spigot end. Any coating removed from the cut end shall be repaired according to manufacturer's recommendation. Cement lining shall be undamaged. Cutting of restrained joint pipe will not be allowed, unless approved at specific joints in conjunction with the use of approved restrainer glands or field adaptable restrained joints. Where field cuts are permitted, the pipe to be cut shall be supplied by the factory as "gauged full length". Should full length gauged pipe be unavailable, the pipe to be cut shall be field gauged at the location of the new spigot using a measuring tape, or other means approved by the manufacturer, to verify that the diameter is within the tolerances permitted in Table 1 of AWWA C151.

Push-on joints shall be made in strict accordance with manufacturer's instructions, AWWA C600 and Appendix B of AWWA C111. If there is conflict, the manufacturer's instructions shall take precedence. Pipe shall be laid with bell ends looking ahead. A rubber gasket shall be inserted in the groove of the bell end of the pipe. The joint surfaces shall be cleaned and lubricated and the plain end of the pipe shall be aligned with the bell of the pipe to which it is to



be joined and pushed home. After joining the pipe, a metal feeler shall be used to make certain that the rubber gasket is properly seated.

Mechanical joints shall be assembled in strict accordance with the manufacturer's instructions, AWWA C600 and Appendix A of AWWA C111. If there is conflict, the manufacturer's instructions shall take precedence. Pipe shall be laid with bell ends looking ahead. To assemble the joints in the field, thoroughly clean and lubricate the joint surfaces and rubber gasket. Bolts shall be tightened to the specified torques. Under no condition shall extension wrenches or pipe over handle of ordinary ratchet wrench be used to secure greater leverage. After installation, apply a bitumastic coating to bolts and nuts and install polyethylene encasement, if required, as specified.

Bolts in mechanical or restrained joints shall be tightened alternately and evenly. Restraint for mechanical joint pipe shall use retainer glands for restraining joint. All restrained mechanical joints shall be suitable for the specified test pressure. Restrained joints shall be installed according to pipe manufacturer's instructions.

Flanged joints shall be assembled in strict accordance with the manufacturer's instructions and Appendix C of AWWA C111. If there is conflict, the manufacturer's instructions shall take precedence. Extreme care shall be taken to ensure that there is no restraint on opposite ends of pipe or fitting, which would prevent uniform gasket compression, cause unnecessary stress, bending or torsional strains, or distortion of flanges or flanged fittings. Adjoining push-on joints shall not be assembled until flanged joints have been tightened. Flange bolts shall be tightened uniformly to compress the gasket uniformly and obtain a seal. Flange bolts shall be left with approximately 1/2 inch projection beyond the face of the nut after tightening. After installation apply a bitumastic coating to the bolts and nuts as specified.

All fittings, valves and other appurtenances required shall be set and jointed in locations as indicated on the Drawings. Fittings in addition to those shown on the Drawings shall be provided, where required, in crossing utilities which may be encountered upon opening the trench.

Solid sleeve closures and couplings shall be installed for closure as shown on the Drawings and at locations approved by the CWD. Couplings shall not be assembled until adjoining joints have been assembled. After installation, apply a heavy bitumastic coating to bolts and nuts and install protective wrap recommended by the manufacturer as required.

After installation, the pipe, fittings, valves and hydrants (piping system) shall be tested for compliance as specified herein. The Contractor shall furnish all necessary equipment and labor for the hydrostatic pressure test on the pipelines. Contractor shall submit a detailed test procedure to CWD for review at least 10 days before starting a test. All testing shall be conducted in accordance with AWWA C600. Pressure pipelines shall be subjected to a hydrostatic test pressure of 150 psig or 1.5 times the highest working pressure along the test segment, whichever is greater, and the test pressure shall be maintained for a minimum of 2 hours. The hydrostatic testing allowances shall not exceed those listed in AWWA C600. The Contractor shall make any taps and furnish all necessary caps, plugs, restrained bulkheads, gauges, meters, pressure pumps, other equipment, etc. as may be required in conjunction with performing the testing. CWD requires that taps for testing and disinfection be installed within 3 feet of every valve as shown on the drawings, and at intervals not to exceed 500 feet. All valves and valve boxes shall be properly located and installed and operable prior to testing. Restrained bulkheads shall be provided with a sufficient number of outlets for filling and draining the line and for venting air.

CWD will provide a source of supply from the existing treated water distribution system for Contractor's use in filling the lines. The line shall be slowly filled with water and the specified test pressure shall be maintained in the pipe for the entire test period by means of a pump furnished by the Contractor. Contractor shall provide accurate means for measuring the quantity of make-up water required to maintain this pressure. The duration of the pressure test shall not be less than 2 hours. All leaks evident at the surface shall be repaired and leakage eliminated regardless of the total leakage as shown by the tests. Lines which fail to meet tests shall be repaired and retested as necessary until all test requirements are complied with. Defective pipes, fittings, valves, hydrants and other materials and accessories shall be removed and replaced at the Contractor's expense. Contractor shall submit a report containing the results of each pressure and leakage testing to the CWD, and shall obtain pre-approval of this reporting before conducting any tests. CWD reserves the right to attend any pressure and leakage tests performed by the Contractor. No pipe installation will be accepted until the requirements of AWWA C600 have been fulfilled.

At the conclusion of the work, the Contractor shall thoroughly clean all of the pipes by flushing with water or other means to remove all dirt, stones, pieces of wood, or other foreign material and debris which may have entered during the construction period. All debris shall be removed from the pipeline. The lowest segment outlet shall be flushed last to assure debris removal. After the pipe has been cleaned and if the groundwater level is above the pipe or water in the pipe trench is above the pipe following a heavy rain, CWD will inspect the pipe for leaks. If defective pipes, fittings, valves or joints are discovered at this time, they shall be repaired or replaced by the Contractor. Any water used from the existing distribution system for flushing that is discharged shall be dechlorinated and discharged in accordance with all local, state and federal standards.

Ductile iron pipe, fittings and valves for potable water service shall be disinfected after cleaning. Contractor shall provide all necessary equipment for this disinfection. Disinfection shall be in accordance with AWWA C651 standards. Contractor's procedure for disinfection shall be approved in advance by the CWD. Taps for chlorination and sampling shall be installed by the Contractor. Chlorination taps shall be 1 inch minimum, and shall be installed within 3 feet of all valves and at intervals not to exceed 500 feet along the pipelines. The location of all chlorination and sampling taps shall be approved by the CWD.

The general procedure for chlorination shall be first to flush all dirty or discolored water from the pipelines and then introduce chlorine in approved dosages through a tap at one end, while water is being withdrawn at the other end of the line or test segment. The chlorine solution shall remain in the pipeline for a minimum of 24 hours. Disinfection shall be in full accordance with the AWWA C651 standard. Following the chlorination period, all treated water shall be flushed from the lines at their extremities and replaced with water from the distribution system. All treated water flushed from the lines shall be disposed of by discharging by means approved by the CWD and Cambridge DPW. No discharge to any storm sewer or natural watercourse will be allowed. All water flushed from the lines must comply with all local, state and federal requirements and regulations. All successfully pressure tested water main segments must be properly chlorinated and flushed prior to the CWD sampling for bacteria testing. Water main segments that fail the CWD performed bacteria testing must be properly re-chlorinated and flushed before CWD returns to resample the segment for the presence of bacteria. Bacteriological sampling and analysis of the replacement water shall be provided by the Contractor in full accordance with the latest edition of the AWWA C651 standard. Contractor shall make payment for bacteriological sampling and testing as required. The Contractor will be required to rechlorinate, if necessary, and the line shall not be placed into service until all requirements of the Commonwealth of Massachusetts and the CWD are met. Additional testing by a qualified individual for heterotrophic plate count (HPC) and volatile organic compounds (VOCs) shall be completed and recorded on forms as required by the Commonwealth of Massachusetts. Final water quality results shall be consistent with the existing water quality in the CWD's system.

Special disinfecting procedures shall be used in connections to existing mains and where the method outlined above is not practical. Special disinfection procedures shall be submitted to the CWD in advance for approval. If the initial chlorination treatment fails to produce the desired results, the chlorination procedure shall be repeated until sampling and testing has been successfully completed. The Contractor shall submit to the CWD a report and all test results for all sampling, testing and laboratory analysis for each test segment. The scheduling of all disinfection, sampling and testing shall be approved by the CWD and shall be attended by a representative of the CWD. The CWD reserves the right to reschedule the disinfection and sampling to accommodate the CWD. The CWD and Cambridge DPW must be contacted prior to flushing or discharge of chlorinated water.

Excavation, backfilling and compaction for trenches shall be as specified herein and as shown on the Drawing details.

### **Materials**

Valves 4 inch through 12 inch shall be resilient seated gate valves manufactured in accordance with AWWA C509 and as specified herein. Resilient seated gate valves shall be rated for a 200 psi working pressure or be of the same working pressure as the pipe they connect to, whichever is higher. All valves shall be fully manufactured in the United States. All gate valves shall be iron body, bronze mounted, resilient seated, non-rising stem type fitted with "O" ring seals. Valves shall be provided with a minimum of two O ring stem seals. Bonnet and gland bolts and nuts

shall be Type 316 stainless steel. The hot dip process in accordance with ASTM A153 is not acceptable. Allen-wrench type bonnet and gland fastening shall not be acceptable and will be rejected. Wedges shall be totally encapsulated. Units shall be, in addition, UL and FM approved. Cast the word "OPEN" and an arrow indicating direction to open on each valve body or operator. Operating nut for all gate valves shall be 2 inches square. Extensions shall be provided for all gate valves where the depth exceeds 6 feet to the top of the operating nut. Extension stems shall be fabricated from solid steel. Stems shall not be smaller in diameter than the valve stem. Equip stem with wrench nut. Ensure all stem connections are pinned. Valves shall be non-rising stem. AWWA requirements for thrust collar and stem to be integrally cast (not pinned on), and copper alloy valve stems shall be strictly enforced. Valves shall have mechanical joint ends compliant with AWWA C111 unless otherwise noted. A 10 year warranty shall be provided for all resilient seated gate valves furnished on the project. All buried valves shall open right (clockwise) per CWD standards.

Valves larger than 12 inch shall be butterfly valves manufactured in strict accordance with AWWA C504 and as specified herein. Butterfly valves shall be bubble tight at rated pressures. Valve discs shall rotate 90 degrees from full closed to open. Operators shall be assembled to the valve by the valve manufacturer. The valve/operator shall be tested as a complete assembly by the valve manufacturer. The manufacturer shall have produced AWWA butterfly valves for a minimum of five years. Valve bodies shall be constructed of cast iron ASTM A126, Class B. Valves in vaults shall be flanged. Flange drilling shall be in accordance with ANSI B16.1, Class 150. Laying length shall be short body as listed in AWWA C504. Buried valves shall be mechanical joint end conforming to ANSI C111. Valve discs shall be constructed of cast iron ASTM A126 or A48, ductile iron ASTM A536. Material mating with the seat shall be either ni-chrome or Type 316 stainless steel. Rubber valve seats shall be Buna-N. The seat shall be located in the valve body. Seats shall be retained in the valve body by mechanical means without the use of metal retainers or other devices located in the flow stream. If seat retaining hardware in the valve body such as screws and segments are used, they shall be monel. If screws are used, monel plugs shall be affixed in the valve body and tapped to receive these screws. Valve seats located on the valve disc are not acceptable. Valve shafts shall be Type 304 stainless steel, ASTM A276 and shall be of a diameter not less than those listed in AWWA C504, Class 150B. Shaft seals shall be furnished where the shaft projects thru the valve body. Shaft seals shall be standard split-v type packing or of an O-ring design. Shaft seals shall be designed to allow replacement without removing the valve shaft. Valves shall be fitted with sleeve type bearings contained in the trunions of the valve body. Bearing material shall be nylon for valves thru 20 inch and fiberglass with teflon lining for valves 24 inches and larger. Valve manufacturer shall furnish and mount operator suitable for buried service. Operators shall be self-locking and suitable for submergence to 20 feet. A 2 inch square operating nut shall be furnished. Operator stops shall be capable of withstanding an input of 450 ft-lbs. Valve class shall be AWWA Class 150B with operators sized for bi-directional flow. All buried valves shall open right (clockwise) per CWD standards. Valves shall be manufactured by Henry Pratt (the "Groundhog" series); Mueller (Model 3211); Clow/Kennedy/M&H; DeZurik valve companies or approved equal.

All buried gate and butterfly valves shall be provided with extension shafts, operating nuts and valve boxes. Extension shafts shall be Type 304 stainless steel and the operating nut shall be 2 inch square. Shafts shall be designed to provide a factor of safety of not less than four. Operating nuts shall be pinned to the shafts. The top of the operating nut shall be located 2 inch below the rim of the valve box. Valve boxes shall be Buffalo boxes by General Foundry or equal and shall be a heavy pattern cast iron, three piece, telescoping type box with dome base suitable for installation on the buried valves. Inside diameter shall be at least 5 inches. Barrel length shall be at minimum 6 feet and adapted to the depth of cover, with a lap of at least 6 inches when in the most extended position. Covers shall be cast iron with integrally cast direction to open arrow, and the word "WATER" shall also be integrally cast. Aluminum or plastic are not acceptable. A means of lateral support for the valve extension shafts shall be provided in the top portion of the valve box. The cover of the valve boxes shall be close fitting and substantially dirt tight and flush with the top of the box rim. The upper section of each box shall have a top flange of sufficient bearing area to prevent settling and to increase the stability of the box to remain at its respective height. The bottom of the lower section shall enclose the stuffing box and operating nut of the valve and shall be oval. The lower section of the box shall have a bell shaped bottom designed to enclose the operating nut and stuffing box of the valve without settling. An approved operating key or wrench shall be furnished. All fasteners shall be Type 304 stainless steel.

Fire hydrants shall be dry barrel type conforming to the requirements of AWWA C502. Hydrants shall be designed such that the hydrant valve opens against and closes with line pressure preventing loss of water and consequent

flooding in the event of traffic damage. Hydrants shall be designed for 150 psi minimum working pressure and hydrostatically tested as specified in AWWA C502. Hydrants shall have 6 inch mechanical joint inlet connections, two 2 1/2 inch hose connections and one 4 1/2 inch pumper connection. Threads for the hose and pumper connections shall be in accordance with National Standard Thread (NST). Hydrants shall be according to manufacturer's standard pattern. Hydrants shall be equipped with O-ring packing. Each nozzle cap shall be provided with a Buna N rubber washer. Hydrants shall be so arranged that the direction of outlets may be turned 90 degrees without interference with the drip mechanism or obstructing the discharge from any outlet. Each hydrant shall have traffic type ground line construction (breakaway bolts are not acceptable) and permit 360 degree movement of the upper barrel to allow for any alignment without shutting down service and/or removing flange bolts and nuts. A bronze or rustproof steel nut and check nut shall be provided to hold the main hydrant valve on its stem. Hydrant valve opening shall have an area at least equal to that area of a 5 1/4 inches minimum diameter circle and be obstructed only by the valve rod. Each hydrant shall be able to deliver 500 gallons minimum through its two 2 1/2 inch hose nozzles when opened together with a loss of not more than 2 psi in the hydrant. Hydrants shall be designed for installation in a trench that will provide minimum cover as noted on Drawings. Hydrant extensions shall be as manufactured by the company furnishing the hydrants and of a style appropriate for the hydrants as furnished. Contractor is responsible for determining the bury depth of each hydrant prior to placing order for hydrants. The minimum bury depth for hydrant lateral/branch piping shall be 5 feet, unless otherwise approved by the CWD. The length of the hydrant barrel shall be as shown on the Drawings such that when installed with the proper depth of cover on the branch pipeline, the hydrant will be set with the normal ground line of the barrel within the distance of the actual finished ground grade surface elevation shown on the Drawings. Hydrants shall open by turning operating nut to right (clockwise) and shall be marked with a raised arrow and the word "Open" to indicate the direction to turn stem to open hydrant. Hydrants shall be furnished with caps, double galvanized steel hose cap chain, galvanized steel pumper hose cap chain, a galvanized steel chain holder and any other hooks and/or appurtenances required for proper use. Hydrant operating nut shall be AWWA Standard pentagonal type measuring 1-1/2 inches point to flat. Hydrants shall have an automatic drain that is operated by the main valve rod. The drain valve is to open as the main valve is closed and the drain valve is to close as the main valve is opened. The port and seat of the main valve is to be bronze. All iron work to be set below ground, after being thoroughly cleaned, shall be painted with two coats of asphalt varnish specified in AWWA C502. Iron work to be left above ground shall be shop painted with two coats of paint of quality and color to correspond to the present standard of the CWD. Hydrant branch piping and valve shall be minimum 6 inches in diameter. Hydrant tees shall be of the anchor type. The branch shall have a plain end with an integral gland and rotating mechanical joint restraints. Mechanical joint restraint to provide a restrained connection with thrust blocks as required. All new fire hydrants shall be flow tested by the Contractor in the presence of the CWD and the caps shall be color coded according to the present specifications of the CWD.

Manual air release valves shall be installed at the locations as shown on the drawings. Corporation stops, curb stops and valve boxes and covers shall be the same as specified for valves and water service connections. Service piping for manual air release valves shall be 1 inch polyethylene tubing.

Valves, hydrants and appurtenances provided shall be the standard product in regular production by manufacturers whose products have proven reliable in similar service for at least 10 years. If required, the manufacturer shall furnish evidence of installation in satisfactory operation. All units of the same type shall be the product of one manufacturer. Valves shall be designed for buried service and for continuous use with a minimum of maintenance and service required and shall perform the required function without exceeding the safe limits for stress, strain or vibration. In no case will used or damaged valves be acceptable. The selection of equipment to meet the specified design conditions is the responsibility of the Contractor. Both workmanship and material shall be of the very best quality and shall be entirely suitable for the service conditions specified. Valves shall have the name of the maker, nominal size, flow directional arrows, working pressure for which they are designed and standard to which they are manufactured cast in raised letters on some appropriate part of the body. Unless otherwise noted, valves shall have a minimum working pressure of 150 psi or be of the same working pressure as the pipe they connect to, whichever is higher, and suitable for the pressures noted where they are installed. Valves shall be of the same nominal diameter as the pipe or fittings they are connected to. Except as otherwise noted, joints shall be mechanical joints, with joint restraint as required.

The interior ferrous metal surfaces, except finished or bearing surfaces, shall be blast cleaned in accordance with SSPC SP-10 and painted with two coats of an approved two component epoxy coating specifically formulated for potable water use. The coating shall be NSF certified to Standard 61.

Exterior ferrous metal surfaces of all buried valves and hydrants shall be blast cleaned in accordance with SSPC SP-6 and given two shop coats of an approved two component coal tar epoxy paint.

### **Construction Methods**

Contractor shall furnish all labor, materials, equipment and incidentals required and provide all buried valves, hydrants and appurtenances complete with actuators and all accessories as shown on the Drawings and as specified herein. Valves, hydrants and appurtenances shall be delivered to the job site, handled and protected in accordance with AWWA standards and in accordance with manufacturer's instructions. Threads and seats shall be protected from corrosion and damage. Rising stems and exposed stem valves shall be coated with a protective oil film which shall be maintained until time of use. Any damaged valves, hydrants and appurtenances shall be removed and replaced by the Contractor at his/her expense.

During installation of all valves and appurtenances, Contractor shall verify that all items are clean, free of defects in material and workmanship and function properly. Valves and appurtenances shall be disinfected prior to installation as outlined in the items for ductile iron water pipe. All valves shall be closed and kept closed until the joints on each side are completely made or as otherwise directed by the CWD. Buried valves shall be cleaned and manually operated before installation. Buried valves and valve boxes shall be set with the stem vertically aligned in the center of the valve box. Valves shall be set on a firm foundation and supported by tamping pipe bedding material under the sides of the valve. The valve box shall be supported during backfilling and maintained in vertical alignment with the top flush with finish grade. The valve box shall be set so as not to transmit traffic loads to the valve. Buried valves and boxes shall be installed in full conformance with AWWA C504 and C509, as applicable, and as specified herein.

Butterfly valves shall be set on their side as shown on the Drawings with the shaft set along the spring line of the pipe with the actuator perpendicular to the shaft. Operating nut shall be set on the valve actuator and vertically aligned in the center of the valve box. Prior to installation, all butterfly valves shall be tested as specified herein. All butterfly valves shall be delivered with blind flanges bolted in place until valve is pressure-tested on site, before installation and burial. The blind flange shall include a 1 inch corporation placed in both the extreme lower and upper portion of the flange for on-site pressure testing prior to installation. All butterfly valves shall be hydrostatically and leak tested as follows:

1. All butterfly valves shall be hydrostatically and leak tested prior to installation. Engineer or CWD shall witness testing of all valves. Contractor shall submit a certification report that each valve has been tested and passed the hydrostatic and leakage tests.
2. To one side of each valve, bolt a blind flange of the same nominal diameter as the butterfly valve being tested. The flange shall include two, 1 inch corporation stops. Each tap shall be placed in the extreme lower and upper portion of the flange.
3. Set the flange tightly to the valve. Water shall be introduced into the lower corporation and shall fill the cavity between the disk and the flange. Water will continue to be supplied until all air has been purged from the cavity.
4. After all air has been purged, install a pressure gauge on the upper corporation.
5. Continue filling the cavity until the pressure is 150 psig or 1.5 times the normal working pressure of the valve, whichever is greater. Maintain this pressure for a minimum of 2 hours. Monitor valve and disk for the presence of any leaks during this time. CWD shall witness testing and verify that each valve is of a satisfactory condition to be installed.

6. It is the responsibility of the installing Contractor that he/she ensures the safety of any persons performing the testing of the valves. No valve shall be tested within City streets. Testing shall be performed at a location approved by the CWD and DPW.

Before backfilling, all exposed portions of any bolts shall be coated with two coats of bituminous paint. Valves shall be backfilled as shown on the Drawings and as directed by the CWD.

Fire hydrants shall be set at the locations as shown on the Drawings and bedded on a firm foundation. Hydrants shall be installed on City of Cambridge property. The CWD and CFD shall review and approve the location of all fire hydrants, should they need to be moved from where shown on the Drawings. Hydrants shall be installed on the property side of the sidewalk and not the curb side of the sidewalk and in locations to minimize damage from traffic and snow plowing operations. Hydrants shall be set in such a way to allow complete turning of a standard hydrant wrench to spin freely while opening or closing the valve. Hydrants and connecting pipe shall have at least the same depth of cover as the distributing pipe. Contractor must confirm bury depth of the water main prior to ordering and installing new hydrants. A drainage pit as detailed on the Drawings shall be filled with screened gravel and compacted. The hydrants shall be set upon a slab of concrete not less than 4 inches thick and 15 inches square. During backfilling, additional screened gravel shall be brought up around and 6 inches over the drain port. Each hydrant shall be set in true vertical alignment and properly braced. Concrete thrust blocks shall be placed between the back of the hydrant inlet and undisturbed soil at the end of the trench. Minimum bearing area for thrust blocks shall be as shown on the Drawings. Felt roofing paper shall be placed around hydrant elbow before placing concrete. Care shall be taken to ensure that concrete does not plug the drain ports. The cement concrete for thrust blocks shall be as specified herein. Hydrants shall be tied to the pipe with suitable rods or clamps, galvanized, painted, or otherwise rustproof treated. Hydrant paint shall be touched up as required after installation. Fire hydrants shall be painted in accordance with CWD's current, standard practice.

Manual air release valves shall be installed at the locations as shown on the Drawings. Corporation stops, service tubing, curb stops and valve boxes and covers shall be installed in accordance with these respective items as specified in this section.

All hardware and appurtenances shall be installed as required and in accordance with manufacturer's recommendations, as acceptable to the CWD.

Contractor shall conduct a functional field test of each valve, including actuators and valve control equipment, and hydrant in presence of the CWD to demonstrate that each part and all components together function correctly. All testing equipment required shall be furnished by the Contractor. Valves, hydrants and other appurtenances shall be tested to demonstrate their conformance with the specified operational capabilities, and any deficiencies shall be corrected or the device shall be replaced or otherwise made acceptable to the CWD. Contractor shall take care not to over pressurize valves or appurtenances during pipe or valve testing. If any connection proves to be defective, it shall be replaced or repaired to the satisfaction of the CWD. All valves, hydrants, appurtenances and other items (including valve interiors) shall be cleaned and disinfected prior to installation, testing and final acceptance. The various pipelines in which valves, hydrants and appurtenances are to be installed are specified to be tested, cleaned and disinfected as described in the items for ductile iron water pipe. All valves, hydrants and appurtenances shall be tested, cleaned and disinfected as part of this work.

### **Materials**

Service pipe shall be soft, annealed seamless copper tubing conforming to ASTM B88, Type K. The name and trademark of the manufacturer shall be stamped along the pipe. All service pipe shall be American manufactured and 1 inch minimum diameter. All service pipe shall conform to AWWA C800 for Underground Service Lines and Fittings.

Corporation stops for service connections shall be brass, lead free and have standard shop threads conforming to AWWA C800 on inlet end and with required joint or coupling for connection to copper pipe. Corporations for 1 inch installations shall be heavy pattern, solid plug, easy turning and of a type equal to the Cambridge Brass Series 301, 302 and/or 311 (depending upon size and location), Mueller H-10003, Ford FB 1600 series or approved equal.

The inlet shall be an AWWA (CC) thread. The outlet shall have male iron pipe thread, one size larger than the inlet. Corporation stops that are 1-1/2 inch and 2 inch shall be of a ball valve type which incorporates Teflon seats to assure self-centering of a Teflon coated bronze ball similar to a style of the Ford FAFB 1600 series or an approved equal by the CWD. All corporations shall be easy turning and non-binding. The inlet shall be an AWWA (CC) thread and the outlet shall be female, iron pipe thread the same as the inlet. All corporations shall be subject to a sustained hydraulic pressure of 200 psi and tested in both the open and closed positions for leakage and ease of turning. All taps greater than 1 inch will require the use of a tapping saddle. All service connections greater than 1 inch shall have valve boxes installed at the corporation stop at the main line pipe.

Curb stops shall be Water Works inverted ground key type, oval or round flow way, tee handle, without a drain, shall be lead free and shall be compliant with AWWA C800. Pipe connections shall be suitable for the type of service pipe used. All parts shall be of bronze with female iron pipe size connections or compression pattern flared tube couplings and shall be designed for a hydrostatic test pressure not less than 200 psi. Curb stops shall have a quarter turn stop with check, solid tee head, no waste and shall be Series FGB-44 by the Ford Meter Box Company, Inc. or approved equal. The curb stop shall have a quarter turn stop with check, solid tee head and no waste. No curb stops with plugged solid waste shall be accepted.

Adapter couplings for connecting new copper tubing to existing service connection shall be standard straight coupling fittings conforming to AWWA C800. Line fittings, if required on new service line, shall be standard three part unions conforming to AWWA C800. All adapter couplings and service fittings shall be extra heavy brass, manufactured by Water Division Products, Cambridge Brass, Ford Meter Box Company, Inc. or approved equal. All services greater than 1 inch shall have a valve box installed at the corporation stop at the main line pipe. When connecting new water service connections to existing portions of the water service, the Contractor may encounter different pipe materials such as steel, brass, lead, etc. Couplings used to connect new to existing services shall electrically isolate the two materials and be comprised of corrosion resistant material.

All curb stops up to 1 inch in size shall be furnished with curb stop service boxes of the extension type with stationary rod and arch pattern base. Services greater than 1 inch shall have a valve box installed at the corporation stop at the mainline pipe. Service boxes shall be cast iron. Plastic will not be allowed for any part of the service boxes. Extension service boxes of the required length and having slide type adjustment shall be installed at all service box locations. The boxes shall have housings of sufficient size to completely cover the service stop and shall be complete with identifying covers which read "Water". Service boxes supplied shall be Erie style, American manufactured, of telescoping type with a length from four to five feet. The cover shall be made of extra grade gray iron. The arch shall accommodate up to a 1 inch curb stop. The upper section shall be a telescoping pipe made of steel. The cover shall be counter sunk with a brass pentagonal plug that features a coarse "rope" thread to enable quick and easy removal. Inside diameter of service boxes shall be a minimum of 2-1/2 inches.

### **Construction Methods**

Furnish all labor, materials, equipment and incidentals required in tapping and making service connections as shown on the Drawings and as directed by the CWD. House and building service connections covered under the scope of this section include all service connections 2 inches and smaller. Connections larger than 2 inches are covered under ductile-iron water pipe and fittings. Furnish all necessary labor and equipment to excavate the trenches, backfill the trenches after the new connections are completed and restore the trench surface as specified. All existing service connections shall be replaced to the property line as shown on the Drawings with new curb stops, corporation stops, copper service tubing and adapters and fittings of the necessary size required. Contractor shall dispose of all existing service connections, service valves, fittings and adapters removed in accordance with all local, state and federal laws and regulations. Any existing water service connection within the project limits shall be replaced with a new service connection, whether or not it is shown on the Drawings. Contractor shall confirm with CWD the location and sizes of all existing service connections.

Corporation stops shall be installed for connecting all services to the new water mains. Keep a record of the locations of all corporation stops installed and indicate on the record those corporation stops that have not been connected to service piping. A copy of this record shall be given to the CWD at the completion of the work. Copper tubing, curb stops and necessary adapters and fittings shall be used to make connections between new corporation stops and new and existing service piping. New curb stops shall be located as shown on the Drawings

for service connections up to and including 1 inch in diameter. For service connections larger than 1 inch in diameter, valve boxes shall be installed directly over the corporation stop at the main. Be responsible for the removal and/or installation of corporation and curb stops in the locations as shown on the Drawings and as directed by the CWD.

All existing services shall be maintained until the new water pipes and service connections have been fully installed, tested and disinfected to the satisfaction of the CWD. All final connections shall then be made to the new mains as specified. Connect each existing service to the new service connections provided after the completed installation of the pipelines has been accepted by the CWD. All abandoned services shall have ends crimped.

No water service connection shall be laid in the same trench with any other utility, except a fire service water pipe. No water service pipe shall be laid within 10 feet horizontally of a sewer, except where it is necessary to cross an existing sewer perpendicularly. In cases where new service connections must cross existing sewers, they shall cross on top of the existing sewer. The minimum bury depth for all water service connections shall be 5 feet unless otherwise approved by the CWD. All connections of water service connections to public water mains shall be made in a public way and shall run 90 degrees perpendicular (the tapping angle is 90 degrees perpendicular) to the main line water pipe. The Contractor shall dispose of all existing service connection materials removed in accordance with all local, state and federal laws and regulations. The CWD requires a separate water service pipe for each premise of different address or ownership.

The tapping machine for corporation stops shall be rigidly fastened to the pipe as near the horizontal diameter as possible. The length of travel of the tap should be so established that when the stop is inserted and tightened with a 14 inch wrench, not more than one to three threads will be exposed on the outside. When a wet tapping machine is used, the corporation stop shall be inserted with the machine while it is still in place. Stops shall be tightened only sufficiently to give water-tightness and care must be constantly exercised not to over-tighten them.

Care shall be exercised in the placing and laying of copper tubing to be sure that the pipe does not have kinks or sharp bends and to assure against it being in contact with sharp stones or ledge which would cause damage to the pipe. At least 6 inches of selected fill shall be placed adjacent to and above the pipe and no stone shall be placed over the pipe until the depth of backfill above the latter is in excess of 1 foot.

Curb stops shall be installed at locations as shown on the Drawings. Install the curb stops and boxes in a workmanlike manner as described herein and as directed by the CWD and compacted screened gravel shall be placed around and below the stop to permit ready draining of the pipe through the waste opening.

Install straight couplings to existing water mains of the sizes required in the locations designated by the CWD in the field. Utilize the manufacturer's recommended installation procedures while performing the work. Care shall be taken to ensure a watertight connection.

Service and valve boxes shall be set in a true vertical position and if they are within the limits of the roadway or within limits where the plowing of snow will take place in the winter, the tops of the boxes shall be set about 1/2 inch below the top of the finished grade. In locations where these boxes are not likely to be disturbed, the tops shall be set flush with the adjoining ground.

## **IRRIGATION CONTROL BOX**

### **MATERIALS:**

Irrigation control boxes shall be the standard required by the CWD in the latest edition of their Construction and Operating Procedures. Corporation stop, copper service tubing, curb stop, service boxes, and adapters and fittings of the necessary size required. Water meters, strainers and reduced pressure zone backflow preventers (RPZ) shall be of the standard type in current use and approved by the CWD as outlined in their Construction and Operating Procedures. RPZ's shall be of the size shown on the Drawings and body shall be constructed of bronze for sizes less than 2 1/2-in and a compact design. Each bronze unit shall be complete with two companion full bore ball valves equipped with test connections. Valves shall be of similar material as that of the backflow device body. Unit shall have replaceable bronze seats and captured springs. Each unit shall be provided with a complete set of spare parts.



Units shall be supported on galvanized steel floor stanchions with floor flange secured to floor. Units shall be of the manufacture that meets the approval of the CWD. Irrigation control boxes are to be provided in suitable enclosures, the final size to be determined by the Contractor based on components as offered. The enclosure shall be of reinforced aluminum construction painted black, providing access through doors for testing of backflow preventer and meter. It must also be totally removable for maintenance purposes. The enclosure shall be structurally lined with a unicellular, non-wicking insulation consisting of a sandwich laminate or applied by spray. Insulation shall provide a minimum R-10 rating. The unit shall be thermostatically controlled to maintain a minimum 40°F within the enclosure with a 3000 Watt heat source mounted to the interior wall to provide protection to -30°F. No wood or “particle board” shall be allowed in assembly. Insulation mounted with glue will be cause for rejection. Power source will be protected with a ground fault circuit interrupting receptacle, UL Standard 943, NEMA 3R, installed by others, inside the box. The enclosure shall contain drain openings sized to accommodate the maximum discharge of the reduced pressure zone assembly. Drain openings shall open to discharge under the most severe conditions. These openings are protected against intrusion of wind, debris or animals. The enclosure shall be provided with a permanent backflow prevention assembly and water meter shall be protected within the enclosure. The enclosure is to be provided with a means of permanent, lockable access doors and/or lid to prohibit theft or vandalism. All portions of the components shall be protected within the enclosure. The enclosure shall be factory assembled and delivered to the site ready to install with no drilling, screwing or riveting of enclosure required on site. The final enclosure size shall be based on the selected equipment it is to house. The enclosure shall have the necessary provisions and Contractor shall coordinate with CWD for Automatic Meter Reading (AMR) system requirements. Enclosure shall be a Watts Regulator Company Series WattsBox, Safe-T-Cover, Hot Box a division of cdf Systems Inc., or equal. Provide pipe supports as required to properly support equipment and valves. It is not warranted that all supports are shown on the Drawings. Pipe supports shall be galvanized steel floor stanchions with floor flange secured to floor.

#### CONSTRUCTION METHODS:

Irrigation control boxes shall be set at the locations as shown on the Drawings and bedded on a firm foundation with suitable concrete pad foundation. The CWD and DPW shall review and approve of the final locations for all irrigation control boxes. Corporation stop, copper service tubing, curb stop and service boxes shall be installed in accordance with these items for water service connections in Section 300. Concrete or equal foundation pad and final enclosure shall be installed in accordance with the manufacturer’s instructions. The final enclosure size shall be based on the selected equipment it is to house.