



BEALS + THOMAS

BEALS AND THOMAS, INC.
Reservoir Corporate Center
144 Turnpike Road
Southborough, MA 01772-2104

T 508.366.0560
F 508.366.4391
www.bealsandthomas.com
Regional Office: Plymouth, MA

July 3, 2018

Mr. H. Theodore Cohen, Chair
Cambridge Planning Board
344 Broadway
Cambridge, MA 02139

Via: Hand Delivery

Reference: Cambridge Crossing Parcel I Residential Design Review Application
PB #179
Cambridge, Massachusetts
B+T Project No. 2084.56

Dear Chairman Cohen and Members of the Board:

On behalf of the Applicant, DW NP Property, LLC (an affiliate of DivcoWest), Beals and Thomas, Inc., respectfully re-submits this Design Review Application for Parcel I Residential (the Site), which is part of the larger Cambridge Crossing (formerly known as NorthPoint) development. The proposed development on Parcel I Residential is proposed to contain a residential building containing approximately 475 to 500 dwelling units comprising approximately 390,000 sf of Gross Floor Area (GFA). Parcel I is located entirely within Cambridge.

As shown on the master plan included as part of this Application, the Site is bounded by Dawes Street to the north, Parcel I open space to the west, Parcel I Retail to the south, and North First Street to the east.

The Site is currently undeveloped vacant land. Parcel I is one of twenty (20) building parcels in the Cambridge Crossing mixed-use development. To date, condominium buildings on Lot S and Lot T, a rental residential building on Lot N, North Point Common, Child Street Park and related infrastructure and other public amenities (including the Brian P. Murphy Memorial Staircase) have been constructed at Cambridge Crossing. In addition, Parcel JK has obtained Design Review approval in Cambridge and Somerville, and building permit applications have been procured in both cities. The Parcel JK building is currently under construction. The surrounding roadway network was approved by the Planning Board on September 2, 2016, as part of Major Amendment #6, and is currently under construction.

The Parcel I Residential building contains approximately 475 to 500 dwelling units and \pm 390,000 sf of GFA. The building is proposed to be 20 stories of occupied floors with two (2) stories of mechanical penthouse. The proposed building will be 220 feet in height, based on the Cambridge definition of building height. Approximately 238 to 250 parking spaces are proposed for Parcel I Residential, all of which will be internal to the building. Approximately 499 to 525 total bicycle parking spaces will be provided on-site.

Mr. H. Theodore Cohen, Chair
Cambridge Planning Board
July 3, 2018
Page 2

A total of 73 short-term bicycle parking spaces will be provided on-site, which includes those located as part of Parcel I Residential, Parcel I Retail, and Parcel I Open Space.

In addition, the Applicant intends to subdivide the Parcel in the manner depicted on the enclosed Draft Subdivision Plan prepared by Beals & Thomas, Inc., dated December 21, 2016, and last updated February 23, 2018, to create three (3) separate parcels within what is now Parcel I: Parcel I-1, I-2, and I-3. The final subdivision plan will be submitted at a later date for approval and endorsement by the Planning Board.

As part of this application, we have included fifteen (15) copies, as well as a flash drive containing an electronic version, of the following materials for review by the Cambridge Planning Board:

- Site Plans;
- Floor Plans and Building Sections;
- Architectural Elevations;
- A Zoning Compliance Summary;
- LEED/Green Building Compliance Summary;
- Shadow Study;
- Complete Wind Study;
- Acoustical Report and Noise Mitigation Narrative;
- Preliminary Signage Plan;
- Compliance Checklist – Zoning Ordinance and NorthPoint Design Guidelines;
- Materials showing the cross-sections of abutting streets;
- Subdivision Plan, previously approved by the Cambridge Planning Board; and
- Draft Subdivision Plan.

There are no changes proposed to the approved uses on the Site nor are there any changes to the layout of roads serving the Site from that shown on the approved 40-scale Roadway Network Schematic Plan.

The Cambridge Crossing team is excited to meet with the Planning Board to review and discuss the evolution of design of the proposed project. Thank you for your consideration of the enclosed.

Very truly yours,

BEALS AND THOMAS, INC.

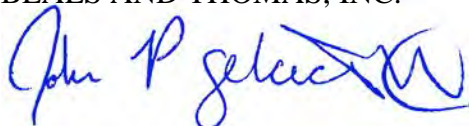

John P. Gelcich, AICP
Senior Planner

JPG/mac/208456PT001D

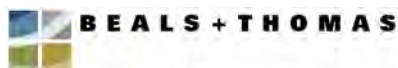



Cambridge Crossing

Cambridge, Massachusetts

Design Review Application – Parcel I Residential



Presented by:

DW NP Property, LLC
c/o DivcoWest Real Estate Investments
200 State Street, 12th Floor
Boston, MA 02109



BEALS + THOMAS

Prepared by:

Beals and Thomas, Inc.
Reservoir Corporate Center
144 Turnpike Road
Southborough, MA 01772

In collaboration with:

CBT Architects
Galluccio & Watson, LLP
Goulston & Storrs PC
Michael Van Valkenburgh Associates, Inc.

Submitted in Compliance with the City of Cambridge Zoning Ordinance and M.G.L. c.40A

July 3, 2018



BEALS + THOMAS

BEALS AND THOMAS, INC.
Reservoir Corporate Center
144 Turnpike Road
Southborough, MA 01772-2104

T 508.366.0560
F 508.366.4391
www.bealsandthomas.com
Regional Office: Plymouth, MA

July 3, 2018

Mr. H. Theodore Cohen, Chair
Cambridge Planning Board
344 Broadway
Cambridge, MA 02139

Via: Hand Delivery

Reference: Cambridge Crossing Parcel I Residential Design Review Application
PB #179
Cambridge, Massachusetts
B+T Project No. 2084.56

Dear Chairman Cohen and Members of the Board:

On behalf of the Applicant, DW NP Property, LLC (an affiliate of DivcoWest), Beals and Thomas, Inc., respectfully re-submits this Design Review Application for Parcel I Residential (the Site), which is part of the larger Cambridge Crossing (formerly known as NorthPoint) development. The proposed development on Parcel I Residential is proposed to contain a residential building containing approximately 475 to 500 dwelling units comprising approximately 390,000 sf of Gross Floor Area (GFA). Parcel I is located entirely within Cambridge.

As shown on the master plan included as part of this Application, the Site is bounded by Dawes Street to the north, Parcel I open space to the west, Parcel I Retail to the south, and North First Street to the east.

The Site is currently undeveloped vacant land. Parcel I is one of twenty (20) building parcels in the Cambridge Crossing mixed-use development. To date, condominium buildings on Lot S and Lot T, a rental residential building on Lot N, North Point Common, Child Street Park and related infrastructure and other public amenities (including the Brian P. Murphy Memorial Staircase) have been constructed at Cambridge Crossing. In addition, Parcel JK has obtained Design Review approval in Cambridge and Somerville, and building permit applications have been procured in both cities. The Parcel JK building is currently under construction. The surrounding roadway network was approved by the Planning Board on September 2, 2016, as part of Major Amendment #6, and is currently under construction.

The Parcel I Residential building contains approximately 475 to 500 dwelling units and \pm 390,000 sf of GFA. The building is proposed to be 20 stories of occupied floors with two (2) stories of mechanical penthouse. The proposed building will be 220 feet in height, based on the Cambridge definition of building height. Approximately 238 to 250 parking spaces are proposed for Parcel I Residential, all of which will be internal to the building. Approximately 499 to 525 total bicycle parking spaces will be provided on-site.

Mr. H. Theodore Cohen, Chair
Cambridge Planning Board
July 3, 2018
Page 2

A total of 73 short-term bicycle parking spaces will be provided on-site, which includes those located as part of Parcel I Residential, Parcel I Retail, and Parcel I Open Space.

In addition, the Applicant intends to subdivide the Parcel in the manner depicted on the enclosed Draft Subdivision Plan prepared by Beals & Thomas, Inc., dated December 21, 2016, and last updated February 23, 2018, to create three (3) separate parcels within what is now Parcel I: Parcel I-1, I-2, and I-3. The final subdivision plan will be submitted at a later date for approval and endorsement by the Planning Board.

As part of this application, we have included fifteen (15) copies, as well as a flash drive containing an electronic version, of the following materials for review by the Cambridge Planning Board:

- Site Plans;
- Floor Plans and Building Sections;
- Architectural Elevations;
- A Zoning Compliance Summary;
- LEED/Green Building Compliance Summary;
- Shadow Study;
- Complete Wind Study;
- Acoustical Report and Noise Mitigation Narrative;
- Preliminary Signage Plan;
- Compliance Checklist – Zoning Ordinance and NorthPoint Design Guidelines;
- Materials showing the cross-sections of abutting streets;
- Subdivision Plan, previously approved by the Cambridge Planning Board; and
- Draft Subdivision Plan.

There are no changes proposed to the approved uses on the Site nor are there any changes to the layout of roads serving the Site from that shown on the approved 40-scale Roadway Network Schematic Plan.

The Cambridge Crossing team is excited to meet with the Planning Board to review and discuss the evolution of design of the proposed project. Thank you for your consideration of the enclosed.

Very truly yours,

BEALS AND THOMAS, INC.

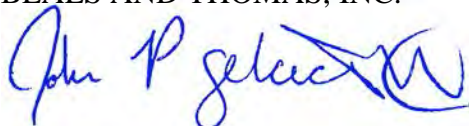

John P. Gelcich, AICP
Senior Planner

JPG/mac/208456PT001D



CAMBRIDGE CROSSING

DEVELOPMENT STATUS TABLE

Phase 1a

Building	Use(s)	Approved GFA per Special Permit Appendix I	GFA approved in thru Design Review	Project Status (i.e., Special Permit, Design Review Completed, Under Construction, Construction Completed)
N	Residential	394,000	394,000 ¹	Construction Completed. Occupied.
	Retail	8,600	8,600	Construction Completed. Occupied.
S	Residential	112,398	112,398	Construction Completed. Occupied.
T	Residential	242,194	242,194	Construction Completed. Occupied.
JK	Office/Laboratory	370,000 Total	351,192	Under construction.
	Retail	TBD	14,700	Under construction.
W	Retail	18,000	16,337	Design Review Complete.
Q1	Retail	17,675 ²	17,675	Minor Amendment Approved for GFA Increase.
L	Residential	286,000 Total		Special Permit approval. Design Review timing TBD.
	Retail	TBD (Allowed)		Special Permit approval. Design Review timing TBD.
M	Residential	208,400 Total		Special Permit approval. Design Review timing TBD.
	Retail	TBD (Required)		Special Permit approval. Design Review timing TBD.
I	Residential	390,000 Total		Special Permit approval. Design Review timing TBD.
	Retail	TBD		Special Permit approval. Design Review timing TBD.

¹ Development of Parcels N, S and T was completed before issuance of Major Amendment No. 6, and, therefore, the revision of Appendix I. As a result, Appendix I reflects the as-built GFA of each of N, S and T.

² Increased by Amendment No. 7 (Minor) from 14,000 square feet of GFA to 17,675 square feet of GFA.

Phase 1b

Building	Use(s)	Approved GFA per Special Permit Appendix I	GFA approved in thru Design Review	Project Status (i.e., Special Permit, Design Review Completed, Under Construction, Construction Completed)
G	Office/Laboratory	410,000	451,000	Special Permit approval. Design Review completed. Design Review completed in Boston.
H	Office/Laboratory	375,000	347,600	Special Permit approval. Design Review completed. Design Review completed in Boston.
EF	Office/Laboratory	400,000 Total	410,590	Special Permit approval. Amendment to Design Review and Site Plan Approval to be submitted.
	Retail	TBD		Special Permit approval. Design Review submitted in Somerville.
C	Mixed-Use	348,000		Special Permit approval. Design Review timing TBD.
U	Office/Laboratory	320,000		Special Permit approval. Design Review timing TBD.

Phase 2

Building	Use(s)	Approved GFA per Special Permit Appendix I	GFA approved in thru Design Review	Project Status (i.e., Special Permit, Design Review Completed, Under Construction, Construction Completed)
A	Residential	175,000		Special Permit approval. Design Review timing TBD.
B	Residential	373,000 Total		Special Permit approval. Design Review timing TBD.
	Retail	TBD (Allowed)		Special Permit approval. Design Review timing TBD.
D	Mixed Use	340,000		Special Permit approval. Design Review timing TBD.
Q2	Office/Laboratory	147,387 Total		Special Permit approval. Design Review timing TBD.
	Retail	TBD (Required)		Special Permit approval. Design Review timing TBD.
R	Mixed Use	148,945 Total		Special Permit approval. Design Review timing TBD.
	Retail	TBD (Required)		Special Permit approval. Design Review timing TBD.
V	Residential	199,855 Total		Special Permit approval. Design Review timing TBD.
	Retail	TBD (Required)		Special Permit approval. Design Review timing TBD.

Special Permit #179, Condition 19.d.

Statistical Summary of Dwelling Units Constructed

Parcel	Total Residential Units	Approved GFA	Use(s)	All Residential Units							
				Studio		1 Bedroom		2 Bedroom		3 Bedroom	
				No. Units	Avg. SF	No. Units	Avg. SF	No. Units	Avg. SF	No. Units	Avg. SF
N	355	402,600	Residential Retail	74	501	180	732	85	1,030	16	1,392
S	99	112,398	Residential	0	--	94	921	5	1,285	0	--
T	230	242,194	Residential	40	663	138	878	51	1,044	1	1,923
JK	--	365,892	Office/Laboratory Retail	--	--	--	--	--	--	--	--

Parcel	Affordable Residential Units	Approved GFA	Use(s)	Affordable Residential Units ¹							
				Studio		1 Bedroom		2 Bedroom		3 Bedroom	
				No. Units	Avg. SF	No. Units	Avg. SF	No. Units	Avg. SF	No. Units	Avg. SF
N	41	402,600	Residential Retail	8	516	21	734	10	1,062	2	1,407
S	12	112,398	Residential	--	--	11	887	1	1,179	--	--
T	26	242,194	Residential	4	678	15	834	6	999	1	1,839
JK	--	365,892	Office/Laboratory Retail	--	--	--	--	--	--	--	--

Issued: July 3, 2018

¹ This chart assumes that these residential properties and affordable units are in compliance with the associated affordable housing covenants on record at the Middlesex County Registry of Deeds (Parcel N: Book 61574 Page 442; Parcel S: Book 45918 Page 224; Parcel T: Book 46408 Page 98). Additional information regarding these properties is available from the Housing Department at CDD.

CAMBRIDGE CROSSING PARCEL I

DESIGN REVIEW PACKAGE

JULY 2, 2018



LOCATION IN MASTER PLAN

PARCEL I
OPEN SPACE

PARCEL I
RESIDENTIAL

PARCEL I
RETAIL

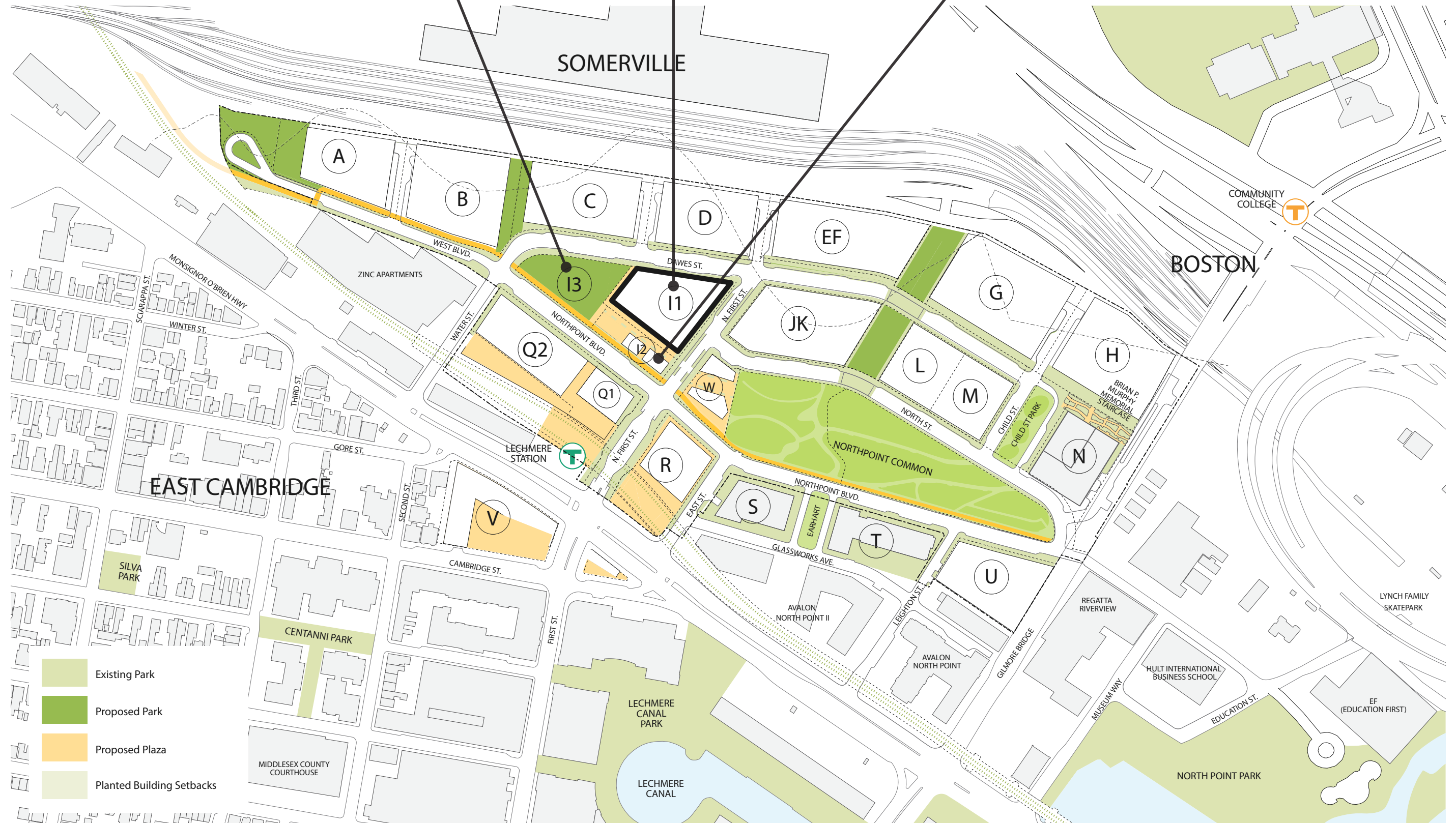

CAMBRIDGE CROSSING - PARCEL I
EXISTING CONDITIONS



DIVCOWEST

cbt

MICHAEL VAN VALKENBURGH ASSOCIATES INC

BEALS + THOMAS

McNAMARA - SALVIA

HALEY ALDRICH

BALA | TMP

NEIGHBOURING BUILDINGS



PARCEL S, PARCEL T, NORTHPOINT COMMON



PARCEL N (TWENTY | 20)



22 WATER STREET (ZINC)



BRIAN P. MURPHY MEMORIAL STAIRCASE



DESIGN & PROJECT DESCRIPTION



390,000 GROSS FLOOR AREA

220' ZONING HEIGHT

20 FLOORS (OCCUPIED)

480 UNITS

240 PARKING SPACES

0.5 VEHICLE SPACES PER UNIT

503 LONG TERM RESIDENTIAL BICYCLE PARKING SPACES

1.05 BICYCLE SPACES PER UNIT

2 LONG TERM RETAIL BICYCLE PARKING SPACES

19,000 SF RETAIL



RELATIONSHIP TO MASTER PLAN



CAMBRIDGE CROSSING - PARCEL I
HEIGHT ZONE COMPLIANCE

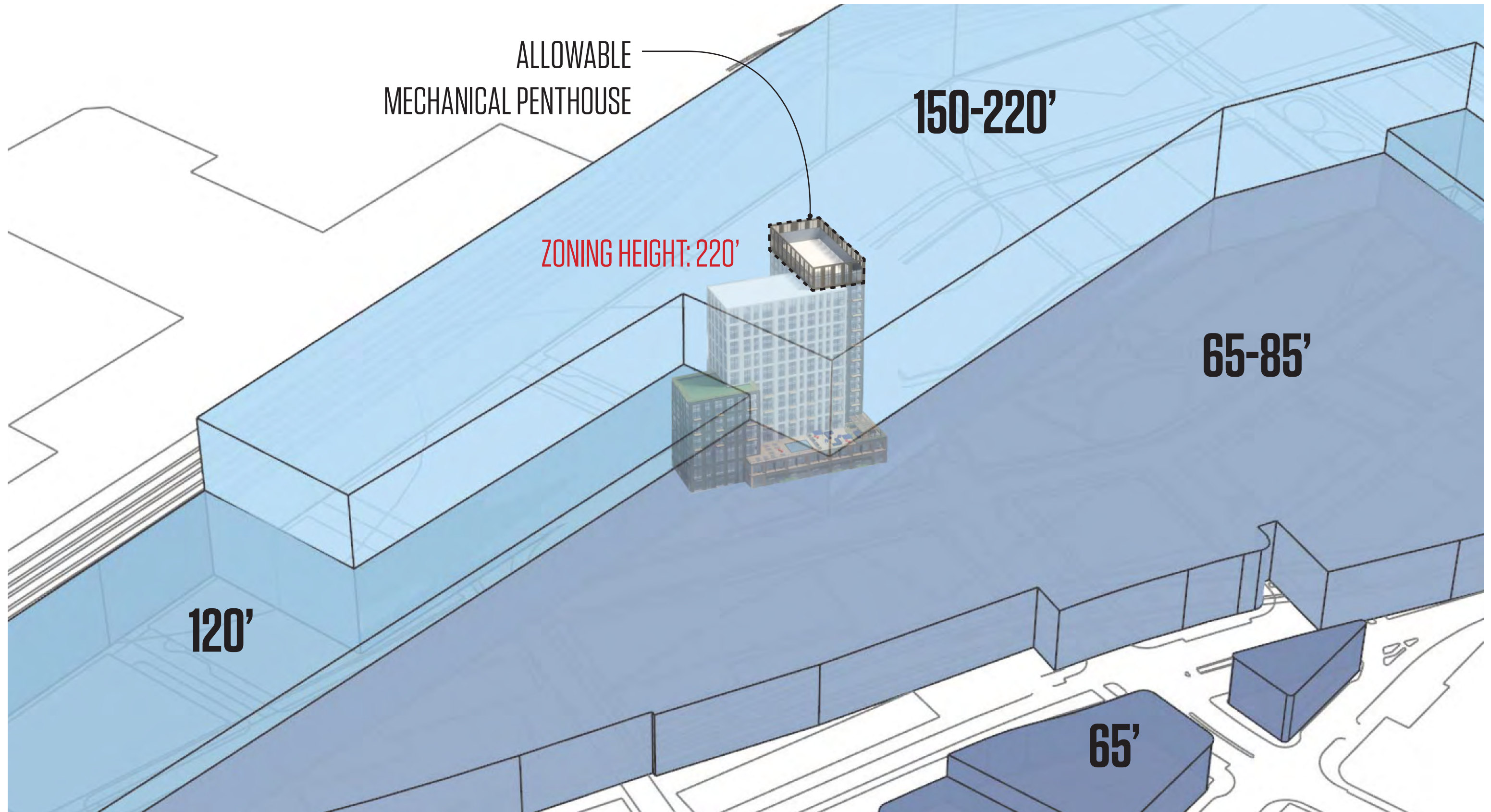

CAMBRIDGE CROSSING - PARCEL I
 EXPANDED LANDSCAPE PLAN

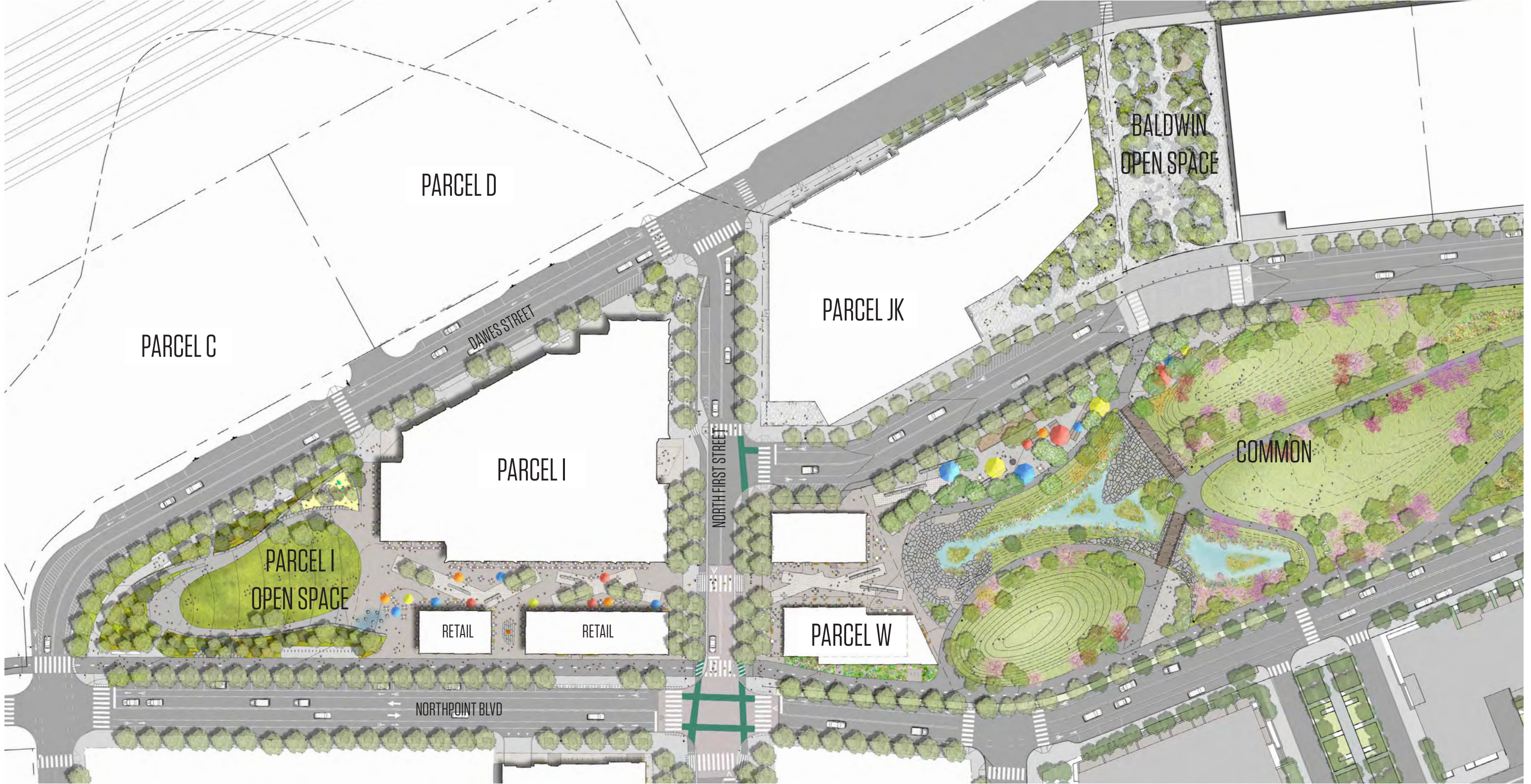

DIVCO WEST

cbt

MICHAEL VAN VALKENBURGH ASSOCIATES INC

BEALS + THOMAS

McNAMARA - SALVIA

HALEY ALDRICH

BALA | TMP

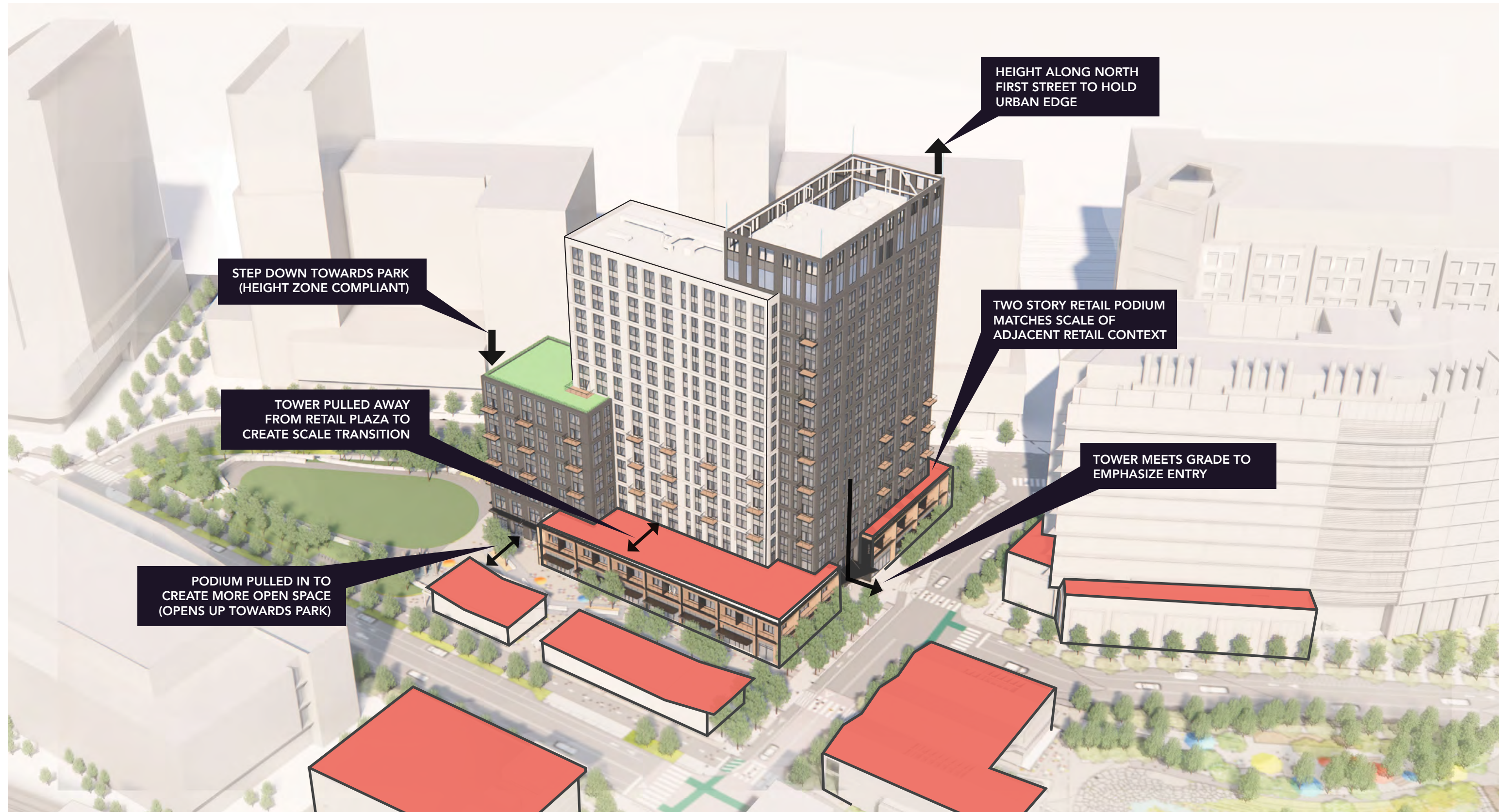

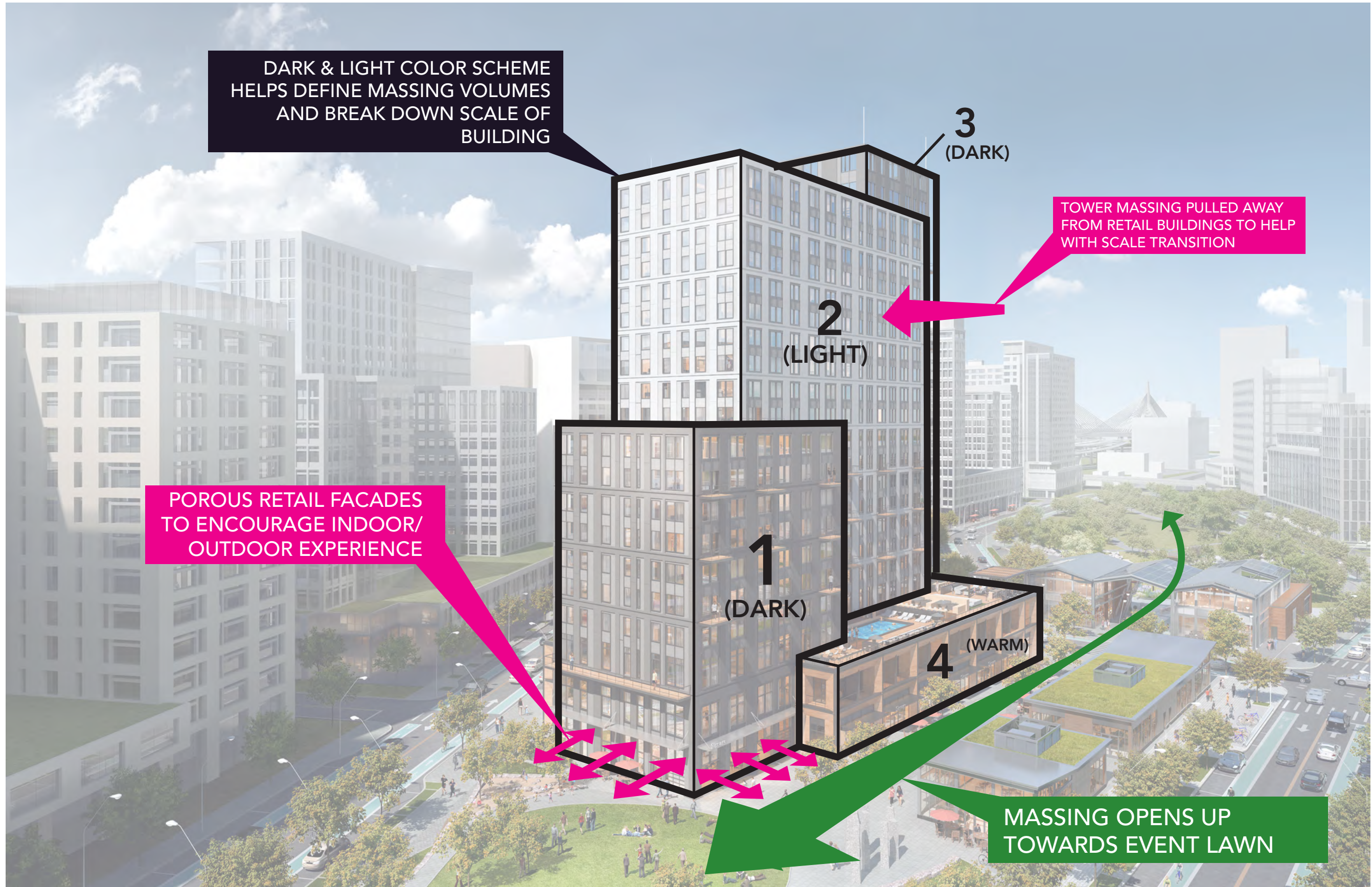



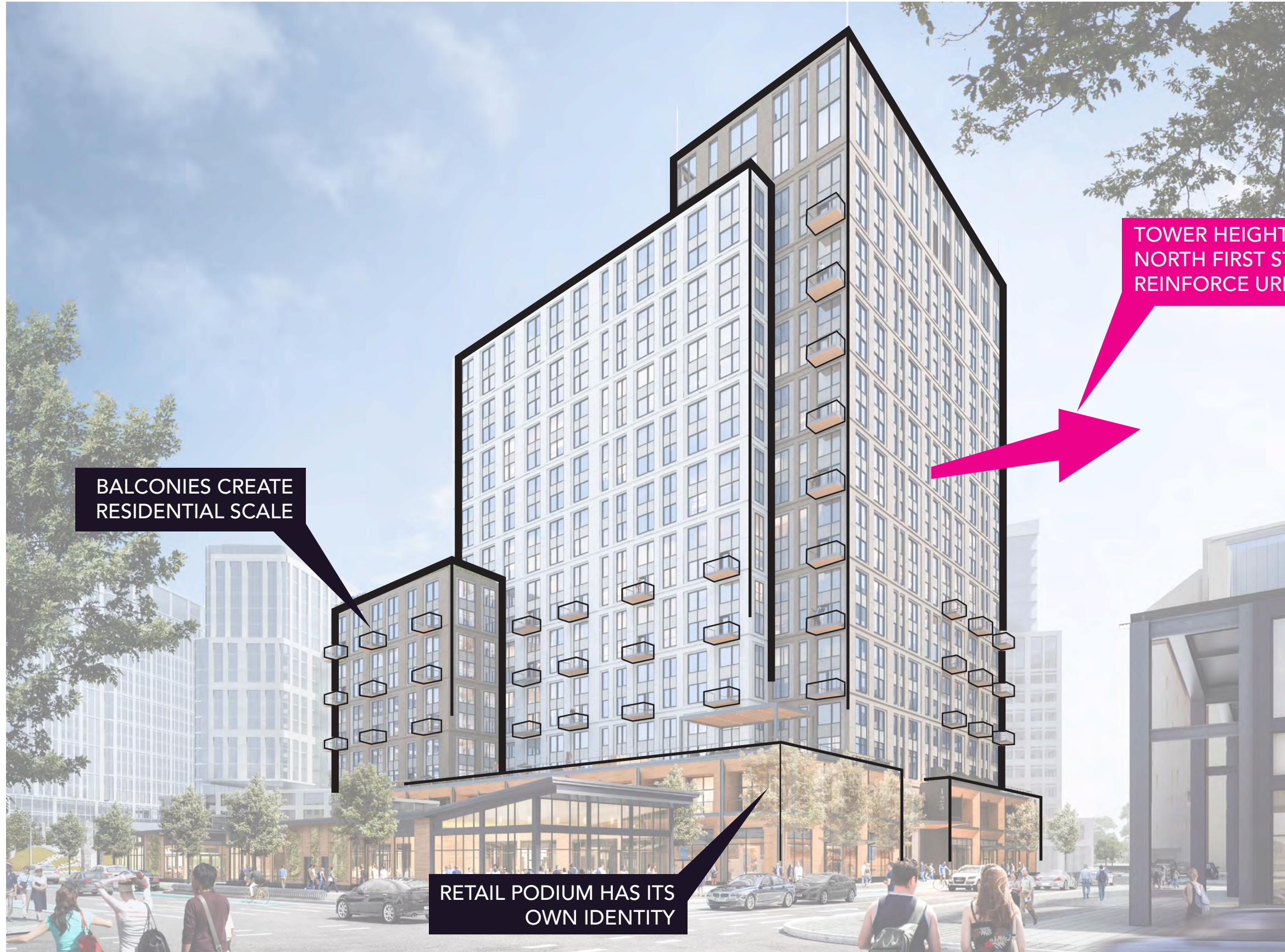

BALCONIES CREATE RESIDENTIAL SCALE

TOWER HEIGHT LOCATED ALONG NORTH FIRST STREET TO REINFORCE URBAN STREET EDGE

RETAIL PODIUM HAS ITS OWN IDENTITY





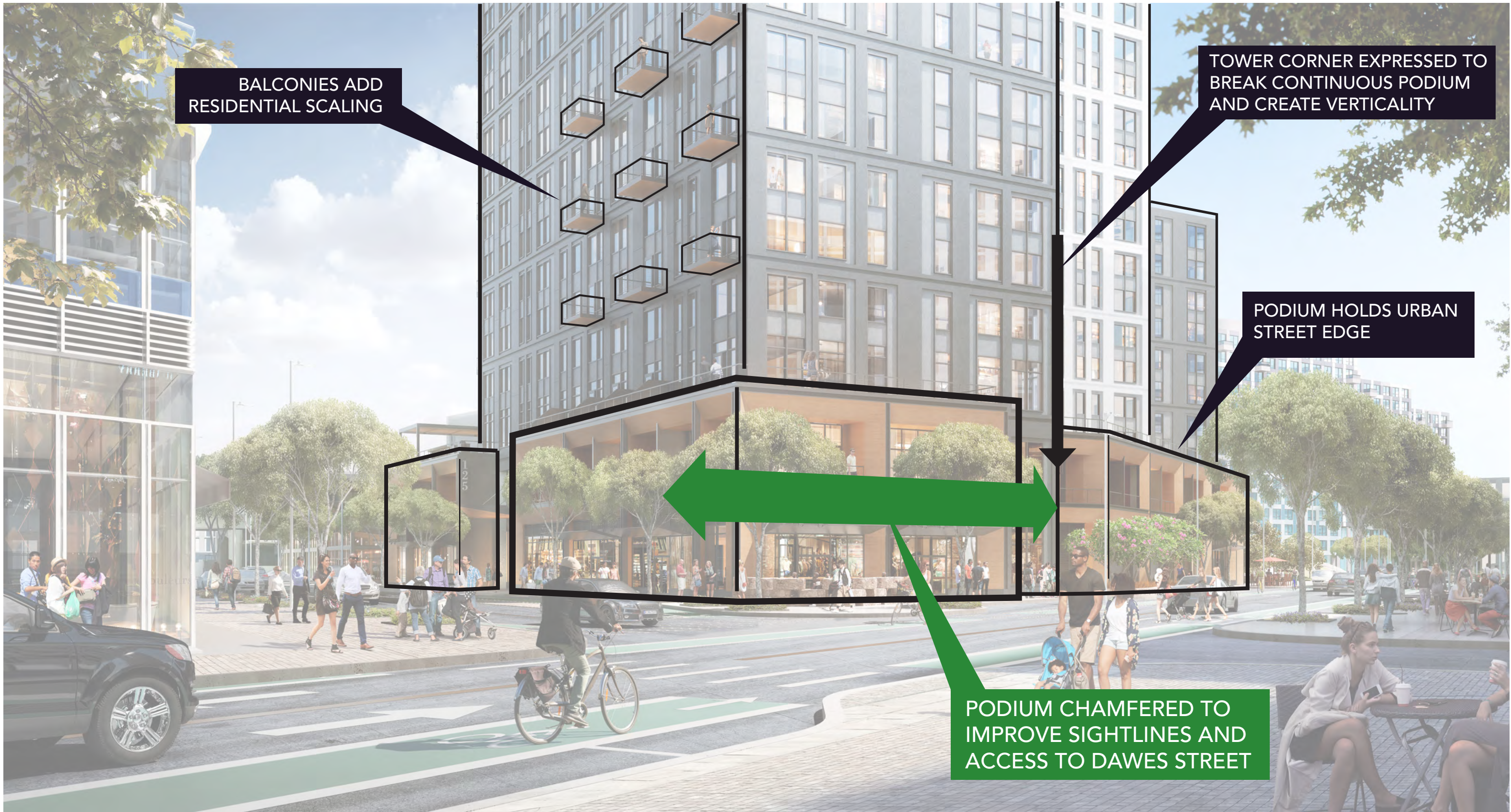

BALCONIES ADD RESIDENTIAL SCALING

TOWER CORNER EXPRESSED TO BREAK CONTINUOUS PODIUM AND CREATE VERTICALITY

PODIUM HOLDS URBAN STREET EDGE

PODIUM CHAMFERED TO IMPROVE SIGHTLINES AND ACCESS TO DAWES STREET





DIVCOWEST

cbt

MICHAEL
VAN
VALKENBURGH
ASSOCIATES
INC

BEALS + THOMAS

McNAMARA · SALVIA

HALEY
ALDRICH

BALA | TMP



DIVCOWEST

cbt

MICHAEL VAN VALKENBURGH ASSOCIATES INC

BEALS + THOMAS

McNAMARA · SALVIA

HALEY ALDRICH

BALA | TMP

BUILDING MATERIALITY

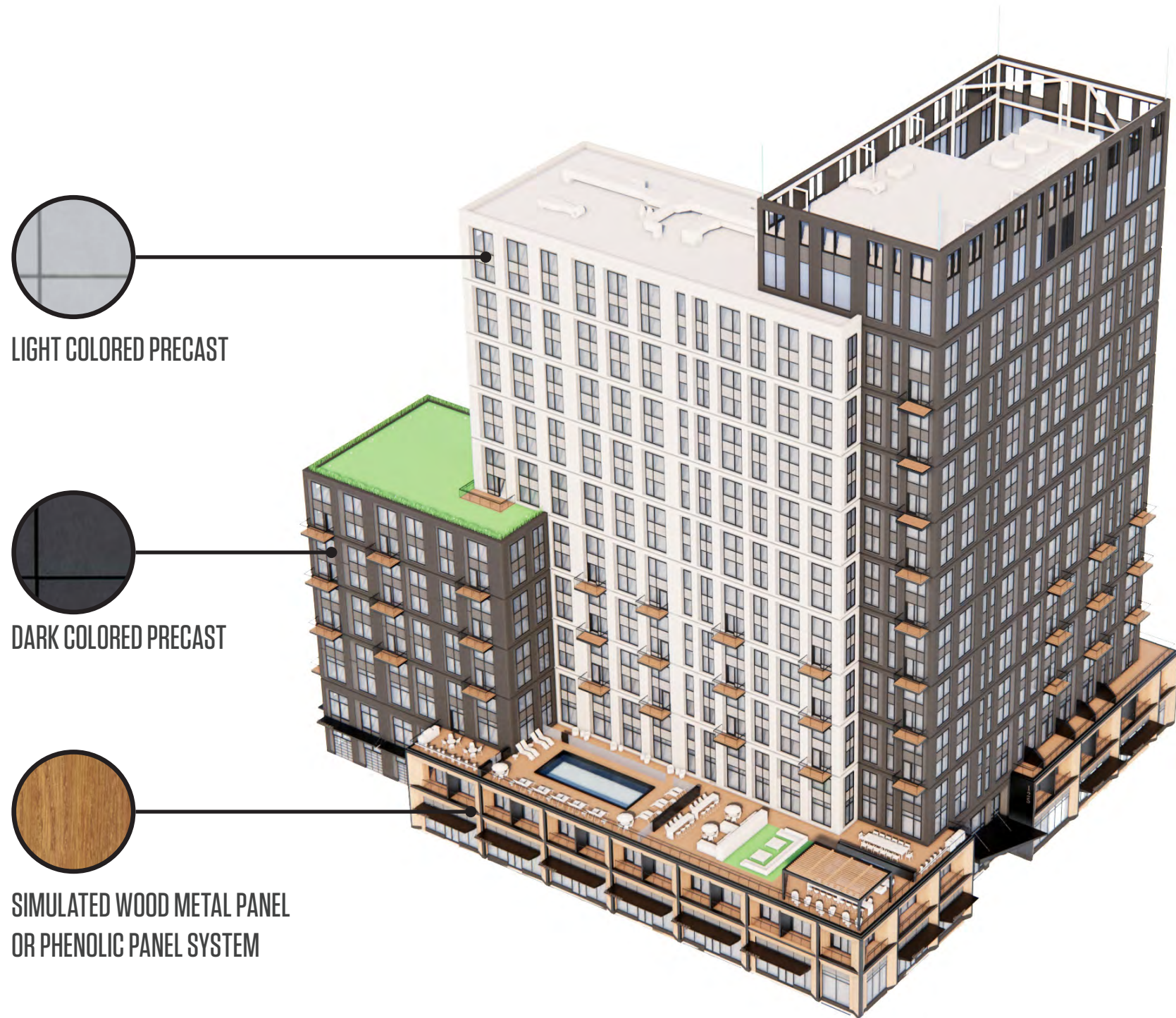

LIGHT COLORED PRECAST

DARK COLORED PRECAST

SIMULATED WOOD METAL PANEL
OR PHENOLIC PANEL SYSTEM

TOWER FACADE SYSTEM

PRECAST CONCRETE W/ MINERAL WOOL INSULATION
PAINTED ALUMINUM GLAZING SYSTEM W/ METAL PANEL SPANDREL
GLAZING BASIS OF DESIGN: SOLARBAN 60

PODIUM FACADE SYSTEM

COMPOSITE METAL OR PHENOLIC PANEL SYSTEM
PAINTED ALUMINUM GLAZING SYSTEM
GLAZING BASIS OF DESIGN: SOLARBAN 60

ROOFING SYSTEM 1 - HIGH ROOF

HIGH ALBEDO ADHERED MEMBRANE ROOFING SYSTEM

ROOFING SYSTEM 2 - GREEN ROOF

FUNCTIONAL GREEN ROOF SYSTEM - 2" MIN. PLANTING TRAYS AS DEFINED
BY ARTICLE 22.30

ROOFING SYSTEM 3 - AMENITY DECK

LEED COMPLIANT (SRI) PAVER/PEDESTAL SYSTEM

ENERGY MODEL PERFORMANCE CRITERIA

ROOF U-VALUE: 0.032
WALL U-VALUE: 0.055
VERTICAL GLAZING: U-VALUE 0.36, SHGC 0.27
WINDOW/WALL RATIO: 40%

PODIUM - FACADE DETAILS

SIMULATED WOOD METAL PANEL
OR PHENOLIC PANEL SYSTEM

PAINTED ALUMINUM
GLAZING SYSTEM

COMPOSITE METAL
PANEL SYSTEM

PAINTED ALUMINUM
LOUVER BAND

METAL PANEL CANOPY
OR SIGNAGE (BY TENANT)

STOREFRONT (BY TENANT)

STONE BASE

METAL GUARDRAIL SYSTEM
W/ HORIZONTAL CABLES

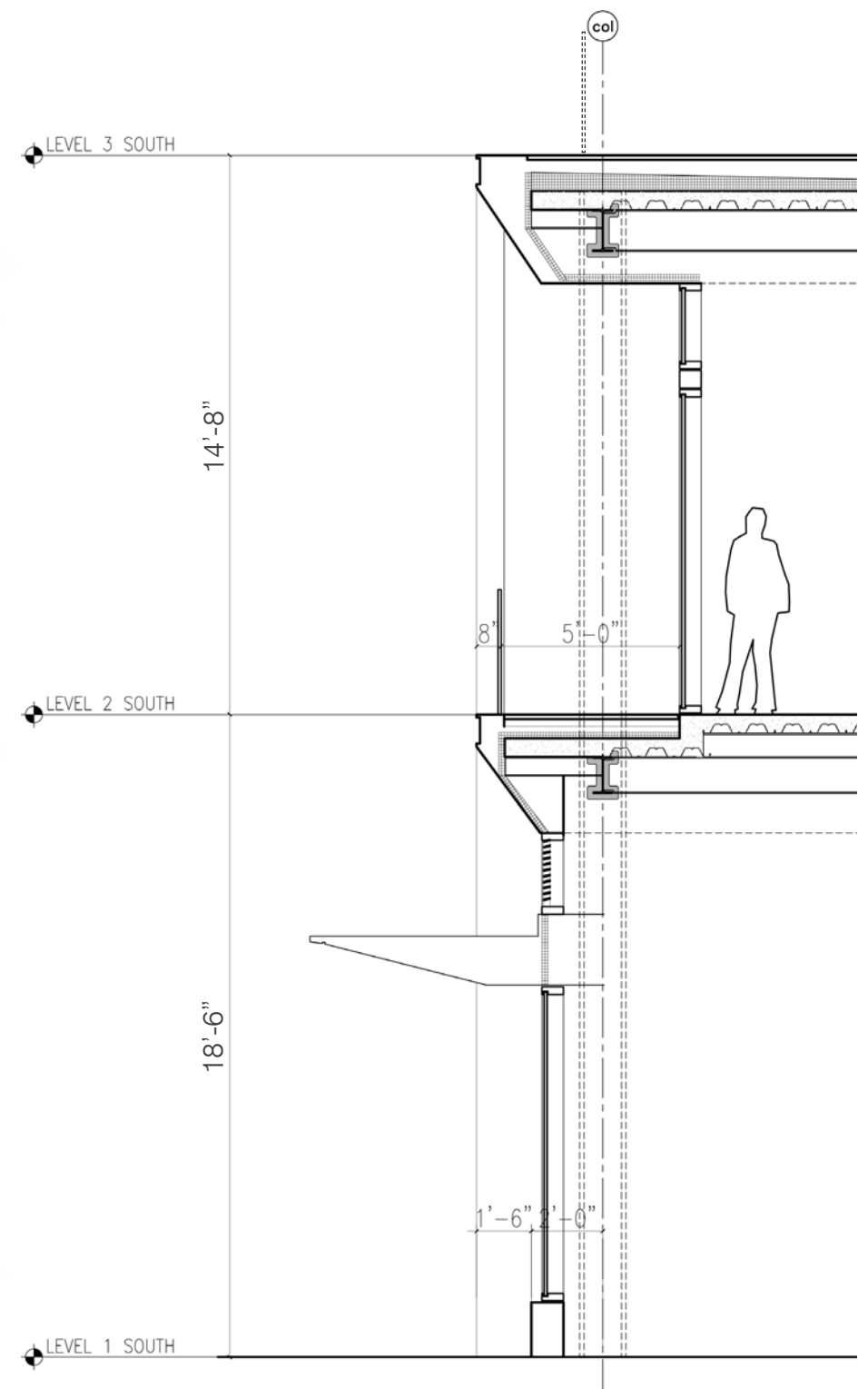
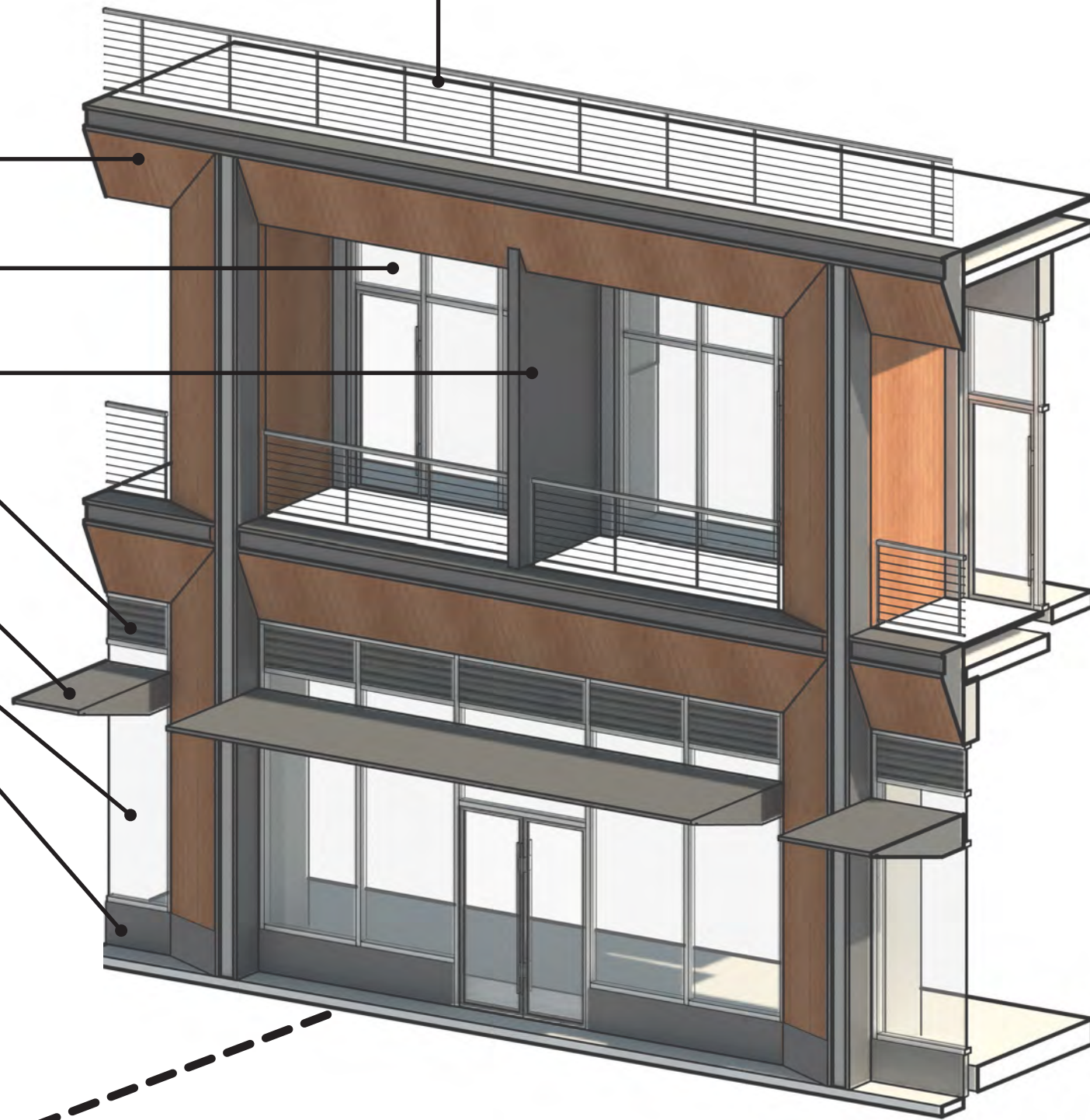

PODIUM AXON

PODIUM SECTION



TOWER - FACADE DETAILS



LIGHT COLORED PRECAST

PRECAST CONCRETE

PRECAST CONCRETE

PAINTED ALUMINUM
GLAZING SYSTEM



TOWER AXON

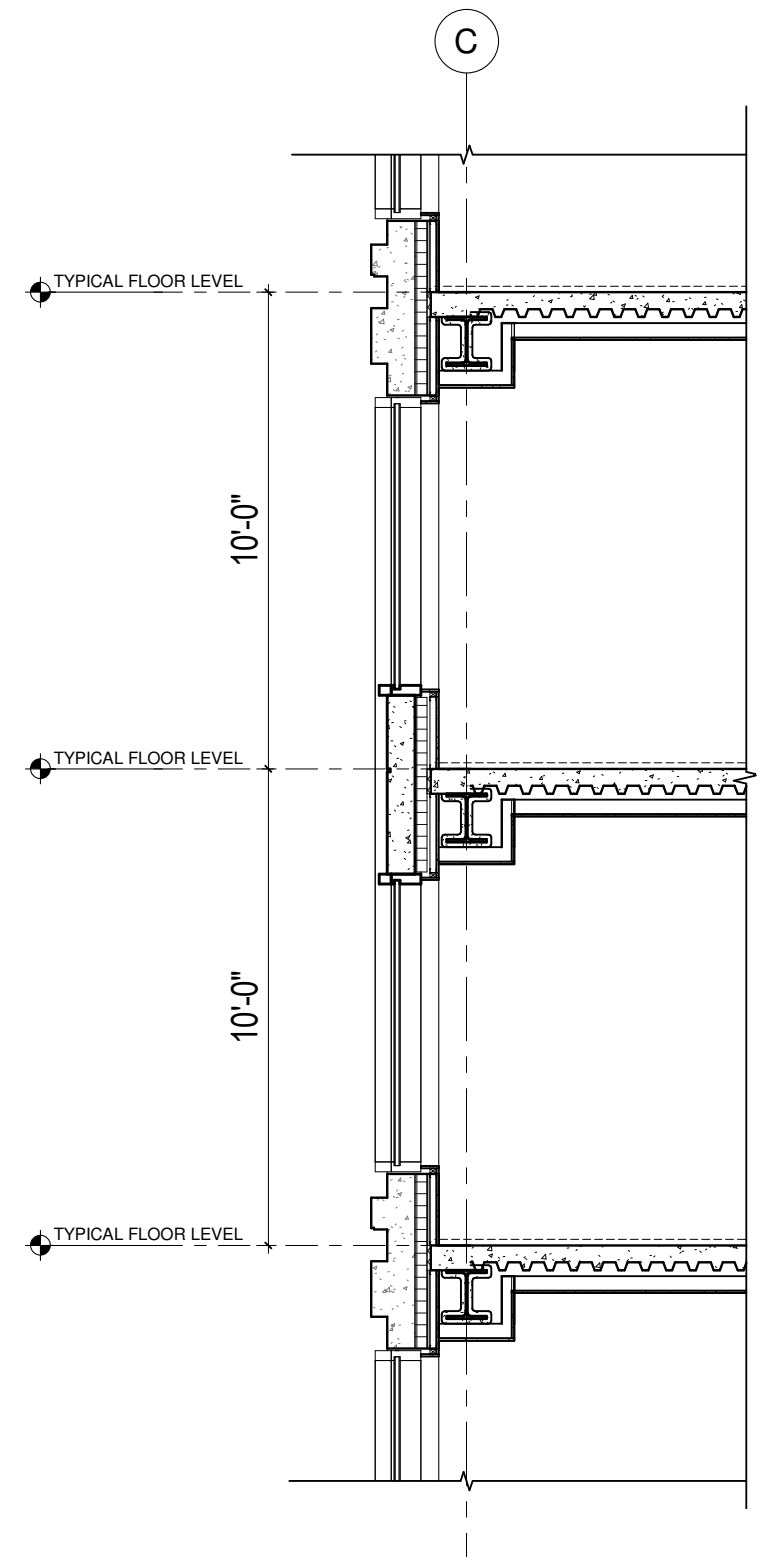

TOWER SECTION



TOWER - FACADE DETAILS



DARK COLORED PRECAST

PRECAST CONCRETE

PRECAST CONCRETE

PAINTED ALUMINUM
GLAZING SYSTEM



TOWER AXON

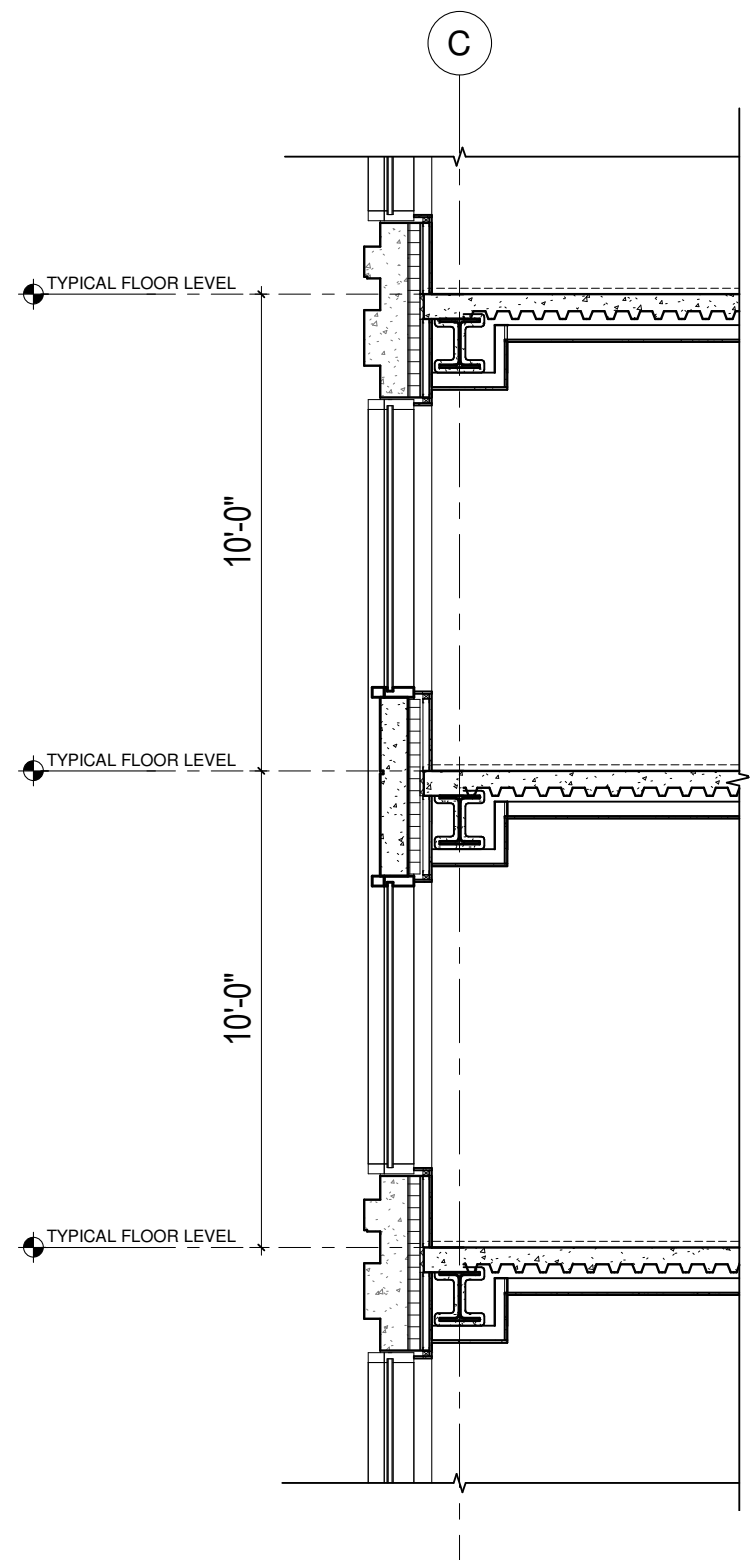

TOWER SECTION



EAST BUILDING ELEVATION

- 21 MECHANICAL

- 20 RESIDENTIAL

- 19 RESIDENTIAL

- 18 RESIDENTIAL

- 17 RESIDENTIAL

- 16 RESIDENTIAL

- 15 RESIDENTIAL

- 14 RESIDENTIAL

- 13 RESIDENTIAL

- 12 RESIDENTIAL

- 11 RESIDENTIAL

- 10 RESIDENTIAL

- 09 RESIDENTIAL

- 08 RESIDENTIAL

- 07 RESIDENTIAL

- 06 RESIDENTIAL

- 05 RESIDENTIAL

- 04 RESIDENTIAL

- 03 RESIDENTIAL / AMENITY

- 02 RESIDENTIAL

- 01 RETAIL

10'-0" FTF
TYP.



- 270'-0"

- TOP OF CFD ANTENNA
- 252'-0"

- TOP OF MECH SCREEN

- 220'-0"

- ZONING HEIGHT
- TOP OF OCCUPIED SPACE

- 120'-0"

- ZONING HEIGHT

- 33'-2"

- PODIUM HEIGHT

- 0'-0"

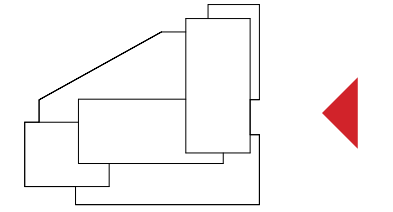

SOUTH BUILDING ELEVATION

- 21 MECHANICAL

- 20 RESIDENTIAL

- 19 RESIDENTIAL

- 18 RESIDENTIAL

- 17 RESIDENTIAL

- 16 RESIDENTIAL

- 15 RESIDENTIAL

- 14 RESIDENTIAL

- 13 RESIDENTIAL

- 12 RESIDENTIAL

- 11 RESIDENTIAL

- 10 RESIDENTIAL

- 09 RESIDENTIAL

- 08 RESIDENTIAL

- 07 RESIDENTIAL

- 06 RESIDENTIAL

- 05 RESIDENTIAL

- 04 RESIDENTIAL

- 03 RESIDENTIAL / AMENITY

- 02 RESIDENTIAL

- 01 RETAIL

10'-0" FTF
TYP.



STOREFRONT, SIGNAGE, AND
AWNINGS BY TENANT

SIGNAGE ZONES

- 270'-0"

- TOP OF CFD ANTENNA
- 252'-0"

- TOP OF MECH SCREEN

- 220'-0"

- ZONING HEIGHT
TOP OF OCCUPIED SPACE

- 120'-0"

- ZONING HEIGHT

- 33'-2"

- PODIUM HEIGHT

- 0'-0"

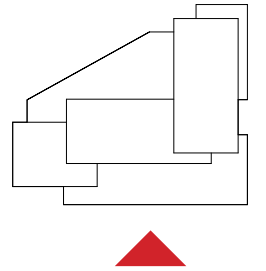

WEST BUILDING ELEVATION

- 21 MECHANICAL

- 20 RESIDENTIAL

- 19 RESIDENTIAL

- 18 RESIDENTIAL

- 17 RESIDENTIAL

- 16 RESIDENTIAL

- 15 RESIDENTIAL

- 14 RESIDENTIAL

- 13 RESIDENTIAL

- 12 RESIDENTIAL

- 11 RESIDENTIAL

- 10 RESIDENTIAL

- 09 RESIDENTIAL

- 08 RESIDENTIAL

- 07 RESIDENTIAL

- 06 RESIDENTIAL

- 05 RESIDENTIAL

- 04 RESIDENTIAL

- 03 RESIDENTIAL / AMENITY

- 02 RESIDENTIAL

- 01 RETAIL

10'-0" FTF
TYP.



270'-0"
TOP OF CFD ANTENNA

252'-0"
TOP OF MECH SCREEN

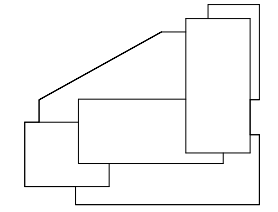

220'-0"
ZONING HEIGHT
TOP OF OCCUPIED SPACE

120'-0"
ZONING HEIGHT

33'-2"
PODIUM HEIGHT

0'-0"



NORTH BUILDING ELEVATION

- 21 MECHANICAL

- 20 RESIDENTIAL

- 19 RESIDENTIAL

- 18 RESIDENTIAL

- 17 RESIDENTIAL

- 16 RESIDENTIAL

- 15 RESIDENTIAL

- 14 RESIDENTIAL

- 13 RESIDENTIAL

- 12 RESIDENTIAL

- 11 RESIDENTIAL

- 10 RESIDENTIAL

- 09 RESIDENTIAL

- 08 RESIDENTIAL

- 07 RESIDENTIAL

- 06 RESIDENTIAL

- 05 RESIDENTIAL

- 04 RESIDENTIAL

- 03 RESIDENTIAL / AMENITY

- 02 RESIDENTIAL

- 01 RETAIL

10'-0" FTF
TYP.



18' TALL CITY OF CAMBRIDGE
FIRE DEPARTMENT MONOPOLE

270'-0"

TOP OF CFD ANTENNA

252'-0"

TOP OF MECH SCREEN

220'-0"

ZONING HEIGHT
TOP OF OCCUPIED SPACE

120'-0"

ZONING HEIGHT

33'-2"

PODIUM HEIGHT

0'-0"

STOREFRONT, SIGNAGE, AND
AWNINGS BY TENANT

GAS METERS

PARKING
ENTRY

TRANS.
VAULT

LOADING

BICYCLE
ENTRY

SIGNAGE ZONES



CAMBRIDGE CROSSING - PARCEL I
BUILDING SECTION

- 21 MECHANICAL

- 20 RESIDENTIAL

- 19 RESIDENTIAL

- 18 RESIDENTIAL

- 17 RESIDENTIAL

- 16 RESIDENTIAL

- 15 RESIDENTIAL

- 14 RESIDENTIAL

- 13 RESIDENTIAL

- 12 RESIDENTIAL

- 11 RESIDENTIAL

- 10 RESIDENTIAL

- 09 RESIDENTIAL

- 08 RESIDENTIAL

- 07 RESIDENTIAL

- 06 RESIDENTIAL

- 05 RESIDENTIAL

- 04 RESIDENTIAL

- 03 RESIDENTIAL / AMENITY

- 02 RESIDENTIAL

- 01 RETAIL

10'-0" FTF
 TYP.

- RESIDENTIAL
- RES. CIRCULATION
- BOH / LOADING
- BIKE PARKING
- RETAIL

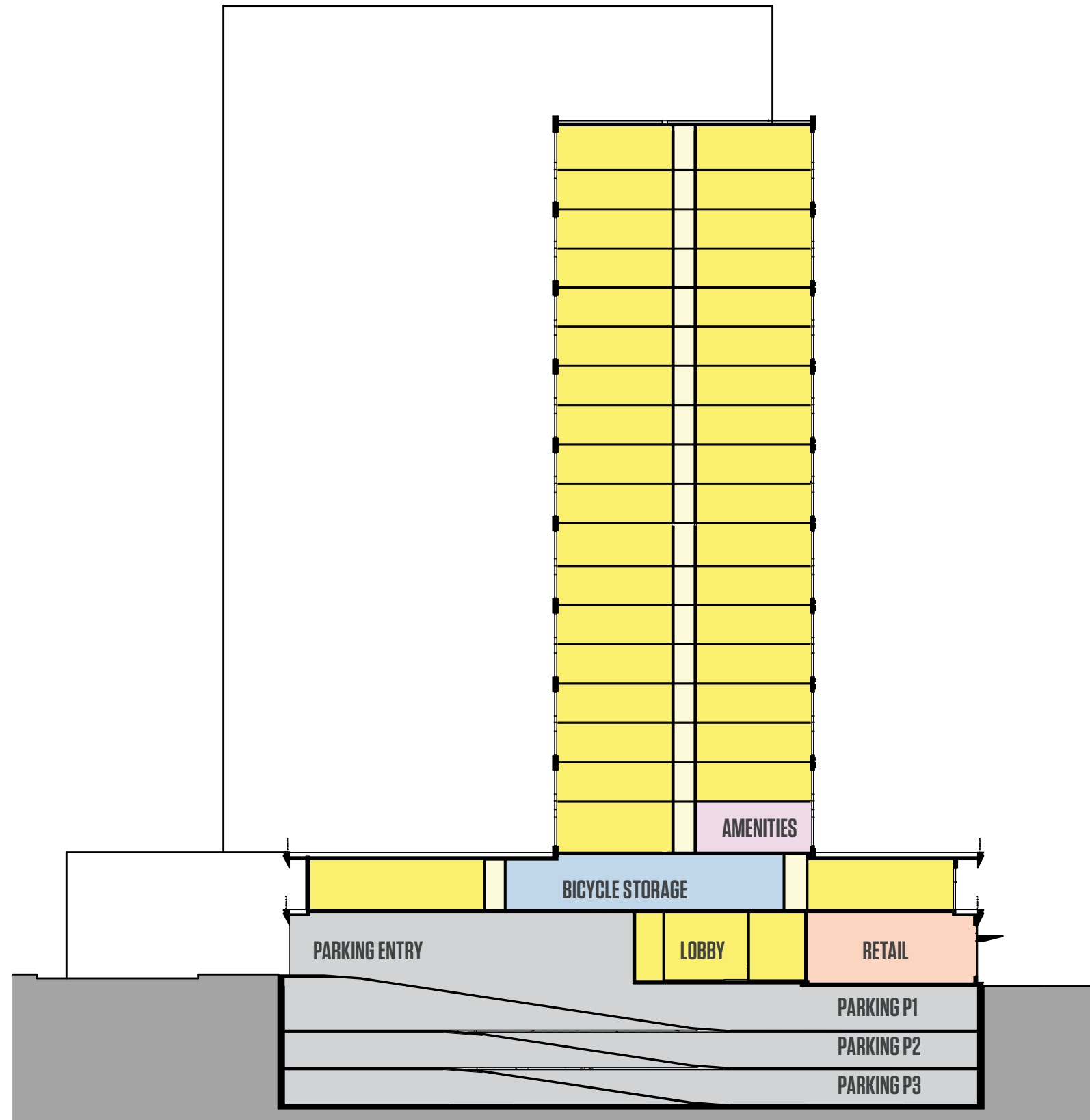

- 252'-0"**
TOP OF MECH SCREEN

- 220'-0"**
ZONING HEIGHT
TOP OF OCCUPIED SPACE

- 120'-0"**
ZONING HEIGHT

- 33'-2"**
PODIUM HEIGHT

- 0'-0"**



CAMBRIDGE CROSSING - PARCEL I
SITE PLAN



- RESIDENTIAL
- RES. CIRCULATION
- BOH / LOADING
- BIKE PARKING
- RETAIL



DIVCO WEST

cbt

MICHAEL VAN VALKENBURGH ASSOCIATES INC

BEALS + THOMAS

McNAMARA - SALVIA

HALEY ALDRICH

BALA | TMP

PLAN - LEVEL P3

Compact (7 1/2 ft x 16 ft):	39
Standard (8 1/2 ft x 18 ft):	44
Handicap (12 ft x 18 ft):	2
Electric Charging (8 1/2 ft x 16 ft):	1
Tandem (7 1/2 x 16 ft):	3 (not included in parking count)

P3 Total Spaces: 86
Including Tandem: 89

P1 Total Spaces: 86
 P2 Total Spaces: 83
 P3 Total Spaces: 71
Total Parking Spaces: 240
Including Tandem: 245

- RESIDENTIAL
- RES. CIRCULATION
- BOH / LOADING
- BIKE PARKING
- RETAIL

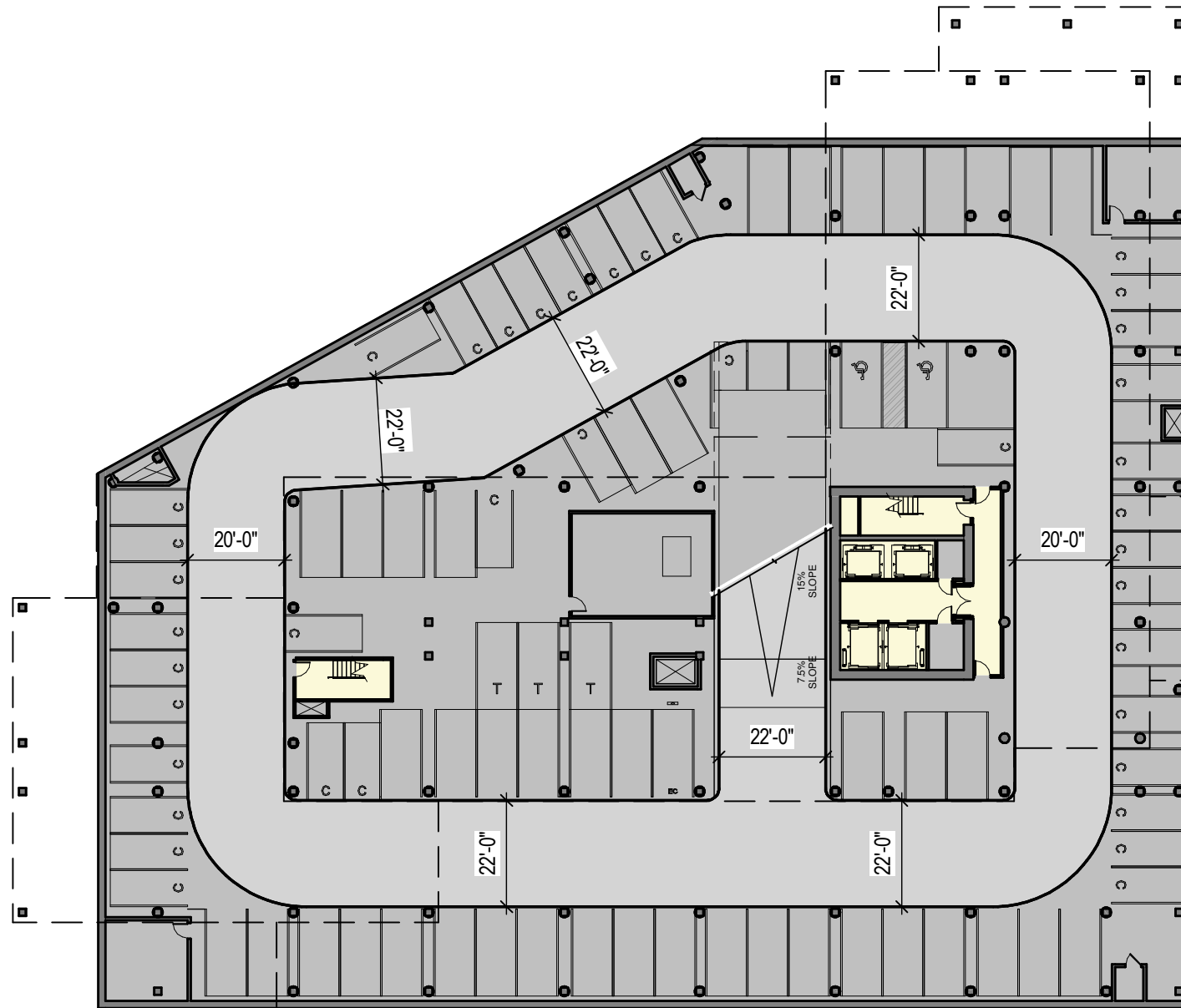

0' 10' 25' 50'

100' N



MICHAEL VAN VALKENBURGH ASSOCIATES INC



PLAN - LEVEL P2

Compact (7 1/2 ft x 16 ft):	38
Standard (8 1/2 ft x 18 ft):	41
Handicap (12 ft x 18 ft):	2
Electric Charging (8 1/2 ft x 16 ft):	2
Tandem (7 1/2 x 16 ft):	2 (not included in parking count)

P2 Total Spaces: 83
Including Tandem: 85

P1 Total Spaces:	86
P2 Total Spaces:	83
P3 Total Spaces:	71
Total Parking Spaces:	240
<i>Including Tandem:</i>	<i>245</i>

- RESIDENTIAL
- RES. CIRCULATION
- BOH / LOADING
- BIKE PARKING
- RETAIL

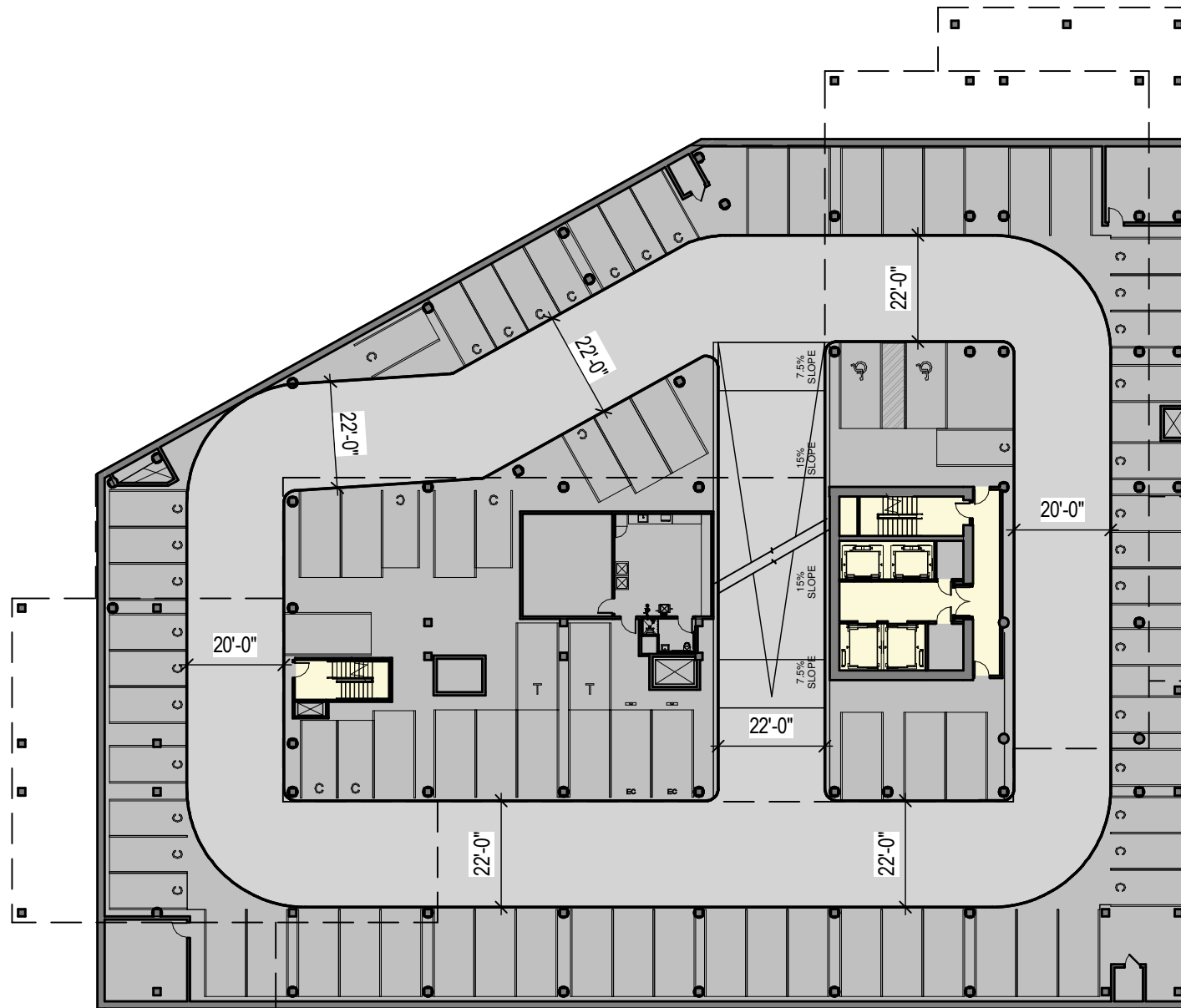

PLAN - LEVEL P1

Compact (7 1/2 ft x 16 ft):	35
Standard (8 1/2 ft x 18 ft):	32
Handicap (12 ft x 18 ft):	2
Electric Charging (8 1/2 ft x 16 ft):	2
Van (12 ft x 18 ft):	1 (not included in parking total)

P1 Total Spaces: 71

P1 Total Spaces:	86
P2 Total Spaces:	83
P3 Total Spaces:	71
Total Parking Spaces:	240
<i>Including Tandem:</i>	<i>245</i>

- RESIDENTIAL
- RES. CIRCULATION
- BOH / LOADING
- BIKE PARKING
- RETAIL

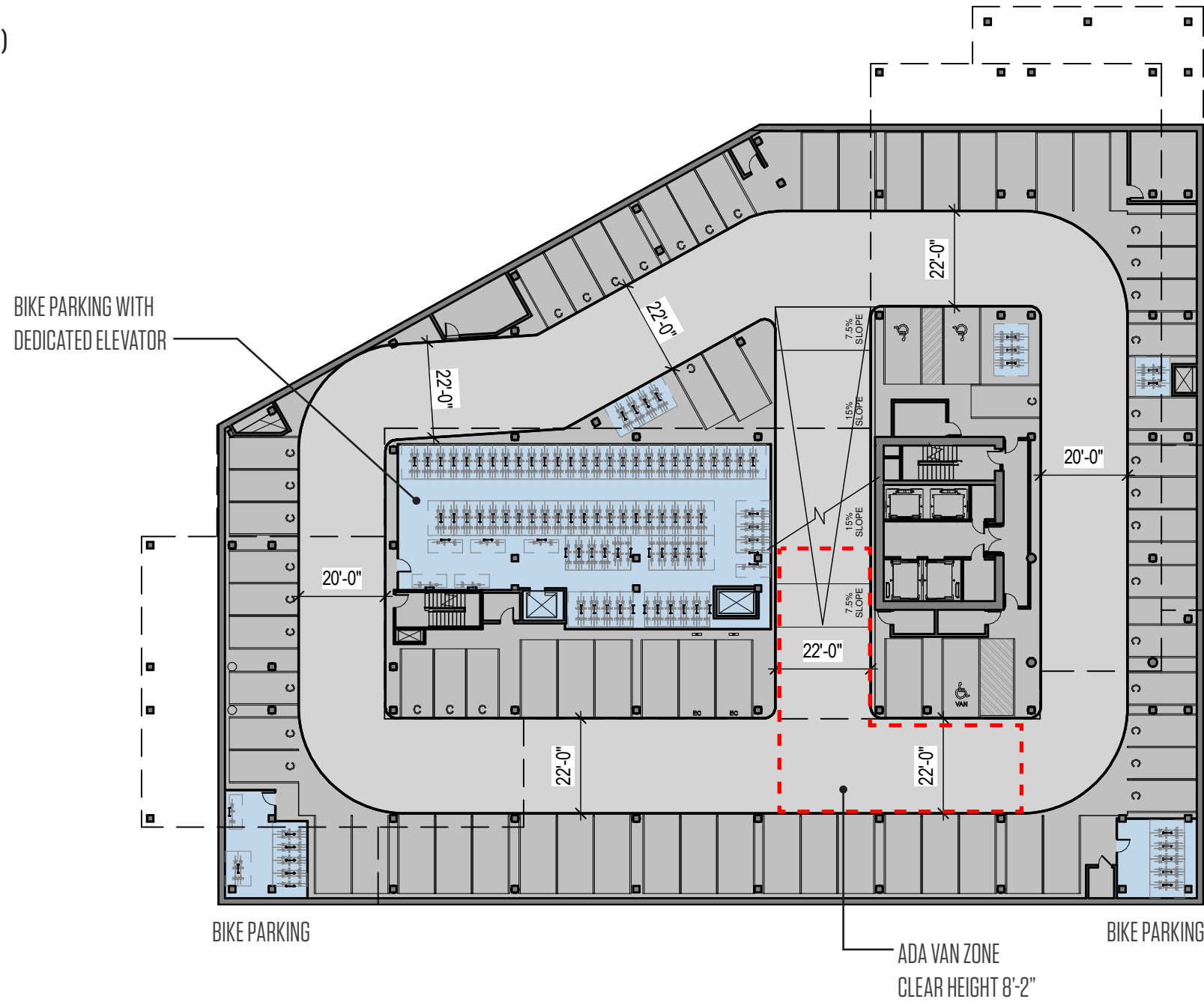

PLAN - GROUND LEVEL



- RESIDENTIAL
- RES. CIRCULATION
- BOH / LOADING
- BIKE PARKING
- RETAIL



CAMBRIDGE CROSSING - PARCEL I
 PLAN - LEVEL 02

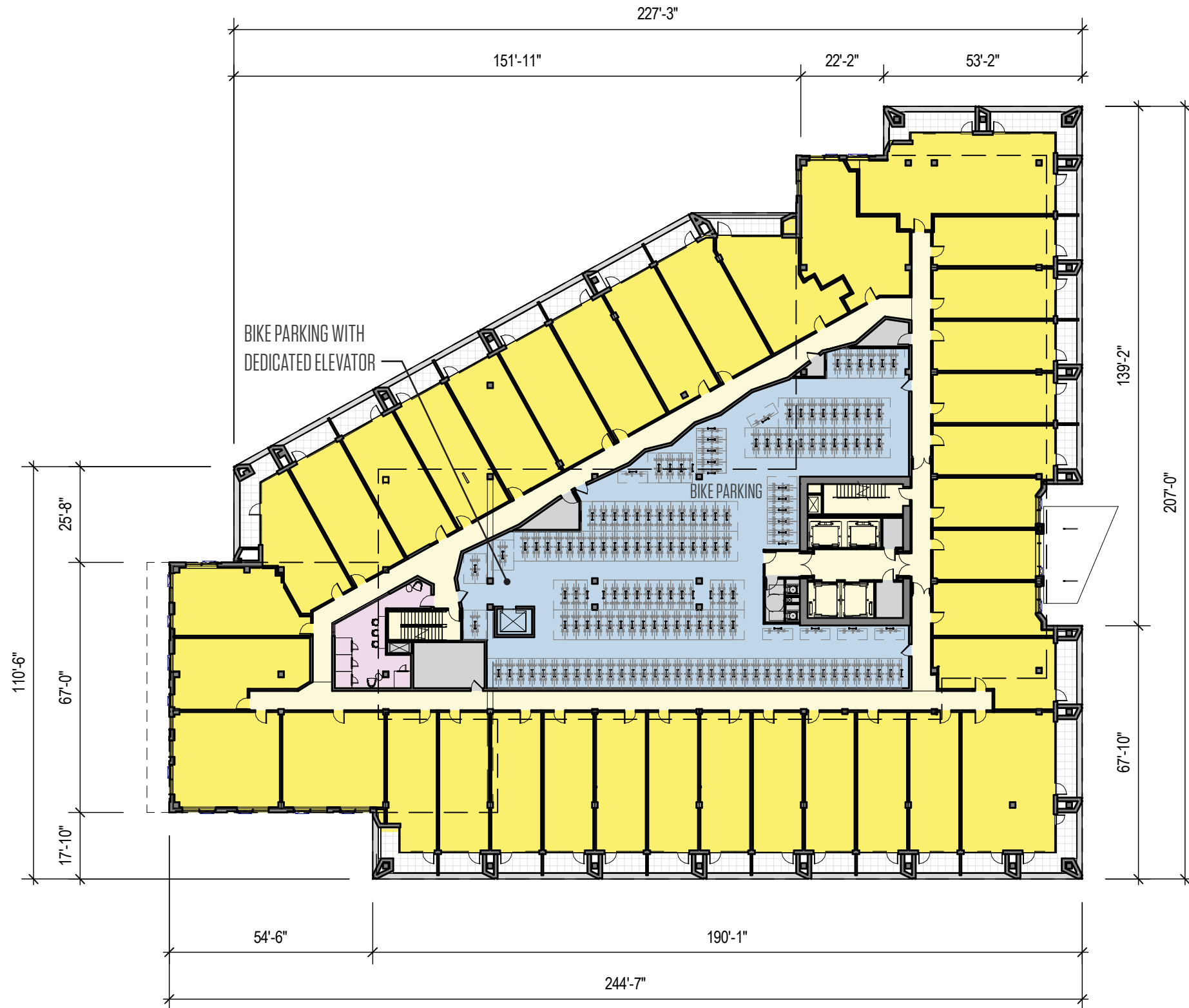

- RESIDENTIAL
- RES. CIRCULATION
- BOH / LOADING
- BIKE PARKING
- RETAIL



CAMBRIDGE CROSSING - PARCEL I
 PLAN - LEVEL 03

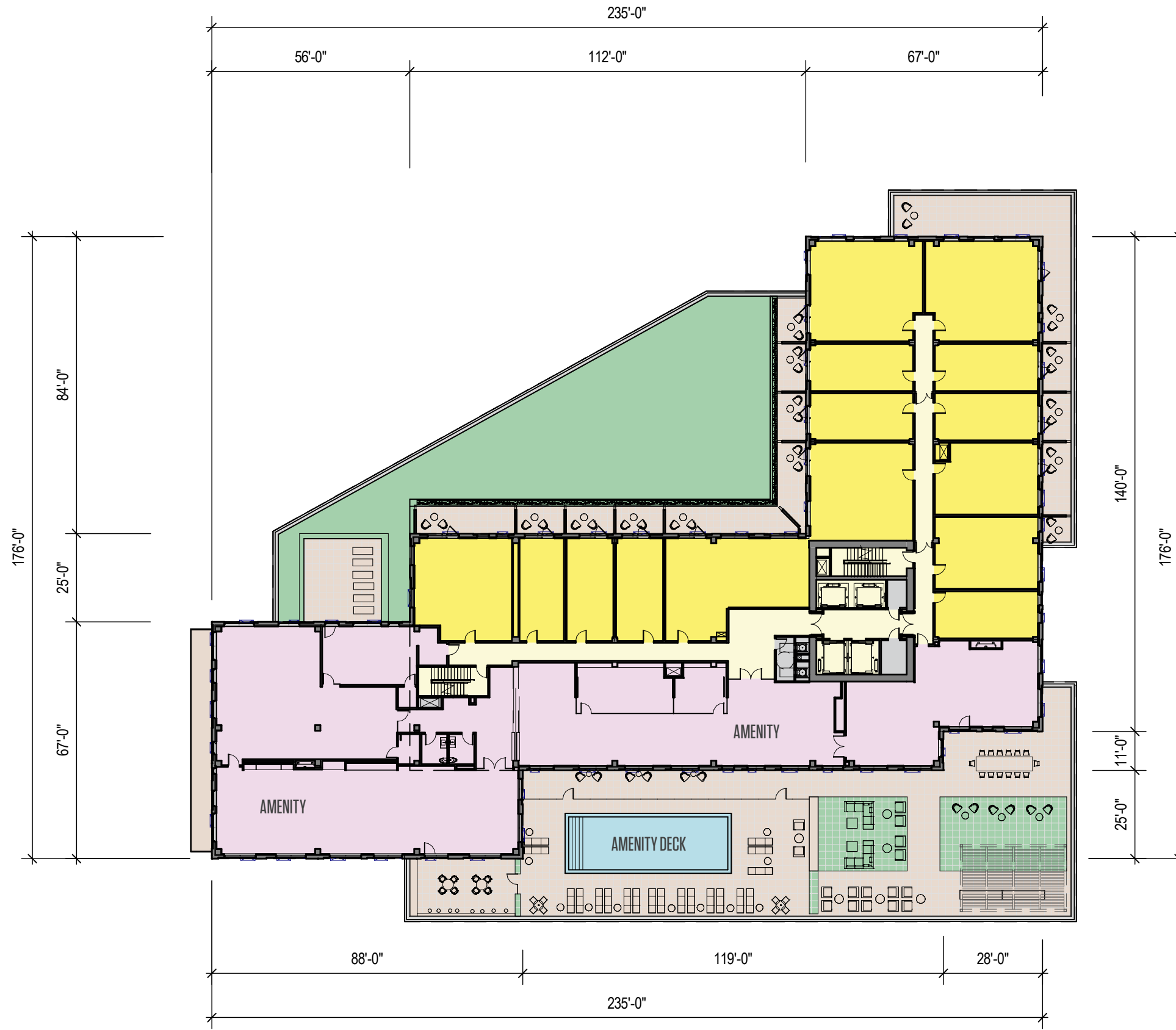

- RESIDENTIAL
- RES. CIRCULATION
- BOH / LOADING
- BIKE PARKING
- RETAIL



CAMBRIDGE CROSSING - PARCEL I
 PLAN - LEVEL 04

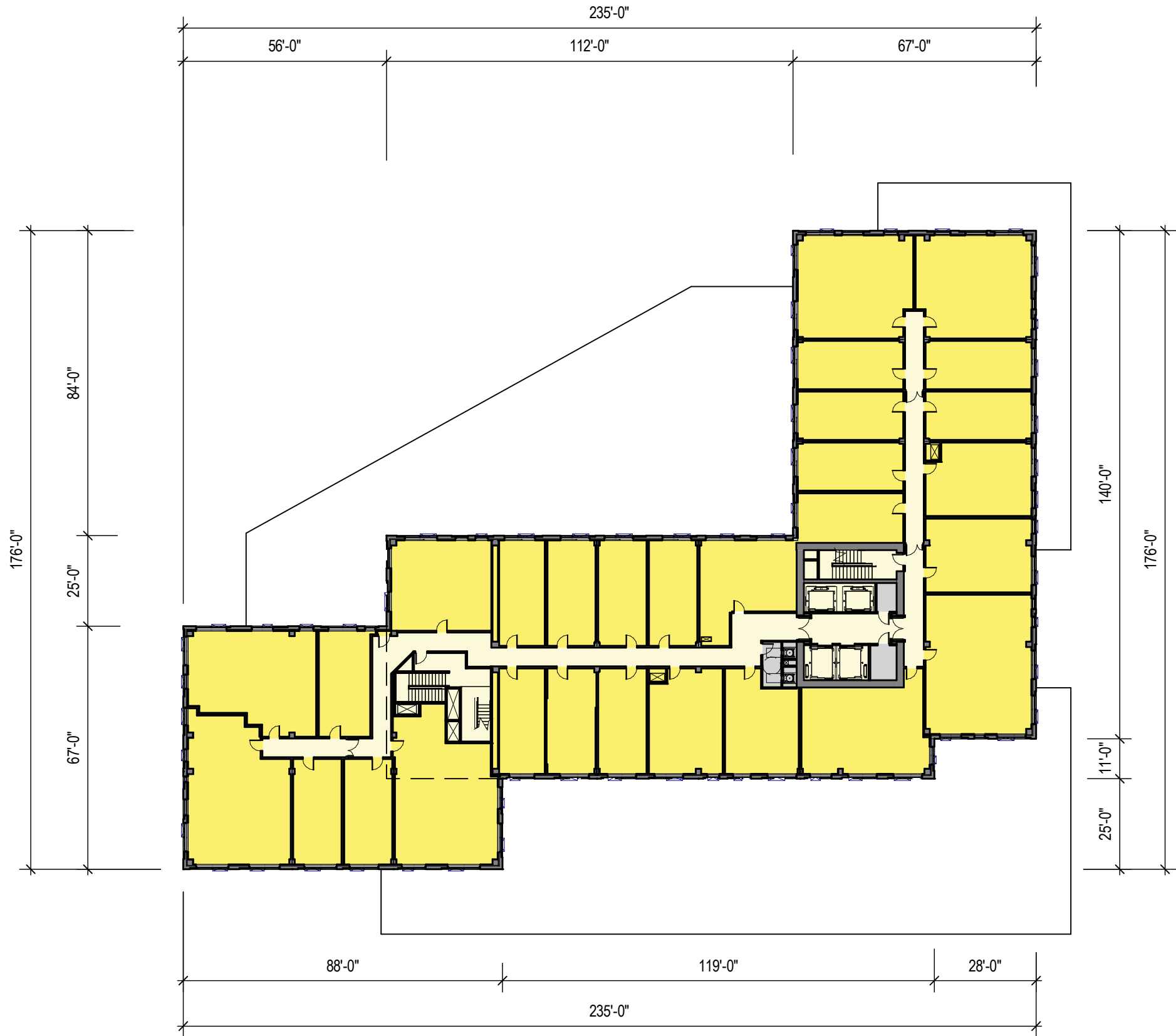

- RESIDENTIAL
- RES. CIRCULATION
- BOH / LOADING
- BIKE PARKING
- RETAIL



CAMBRIDGE CROSSING - PARCEL 1
 PLAN - LEVELS 05-10

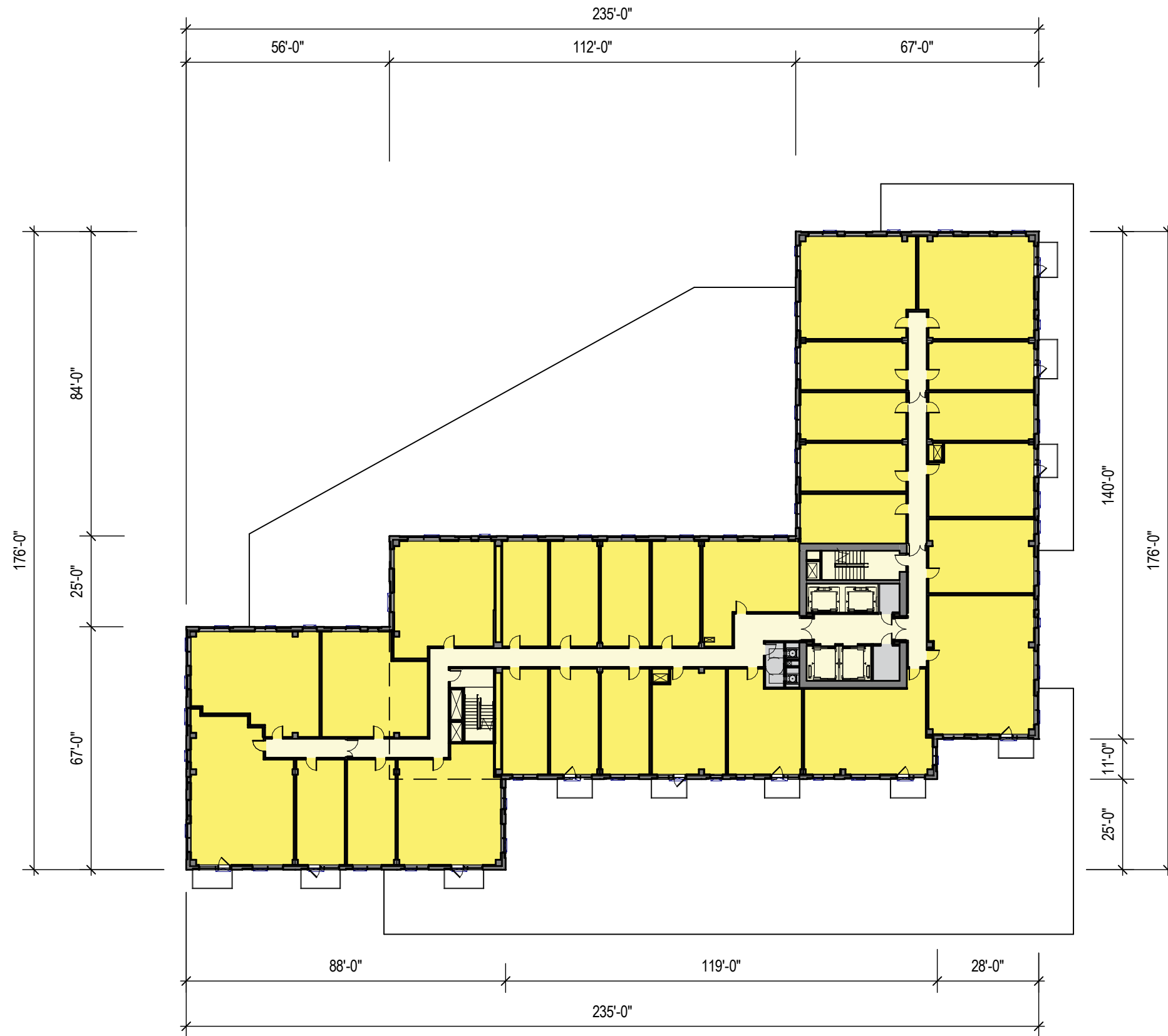

- RESIDENTIAL
- RES. CIRCULATION
- BOH / LOADING
- BIKE PARKING
- RETAIL



MICHAEL VAN VALKENBURGH ASSOCIATES INC



CAMBRIDGE CROSSING - PARCEL I
 PLAN - LEVEL 11

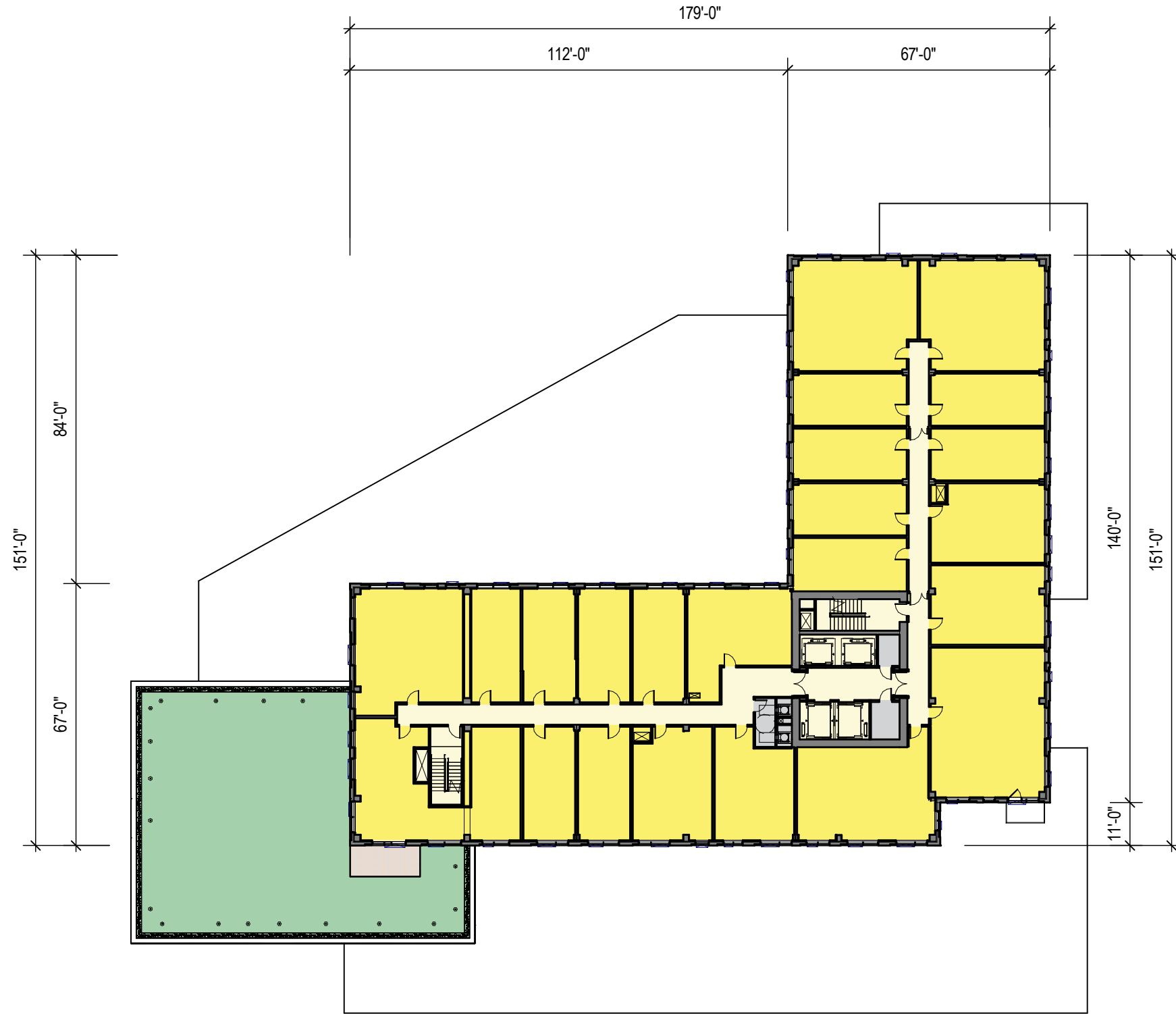

- RESIDENTIAL
- RES. CIRCULATION
- BOH / LOADING
- BIKE PARKING
- RETAIL



DIVCOWEST

cbt

MICHAEL VAN VALKENBURGH ASSOCIATES INC

BEALS + THOMAS

McNAMARA · SALVIA

HALEY ALDRICH

BALA | TMP

CAMBRIDGE CROSSING - PARCEL I
 PLAN - LEVELS 12-18

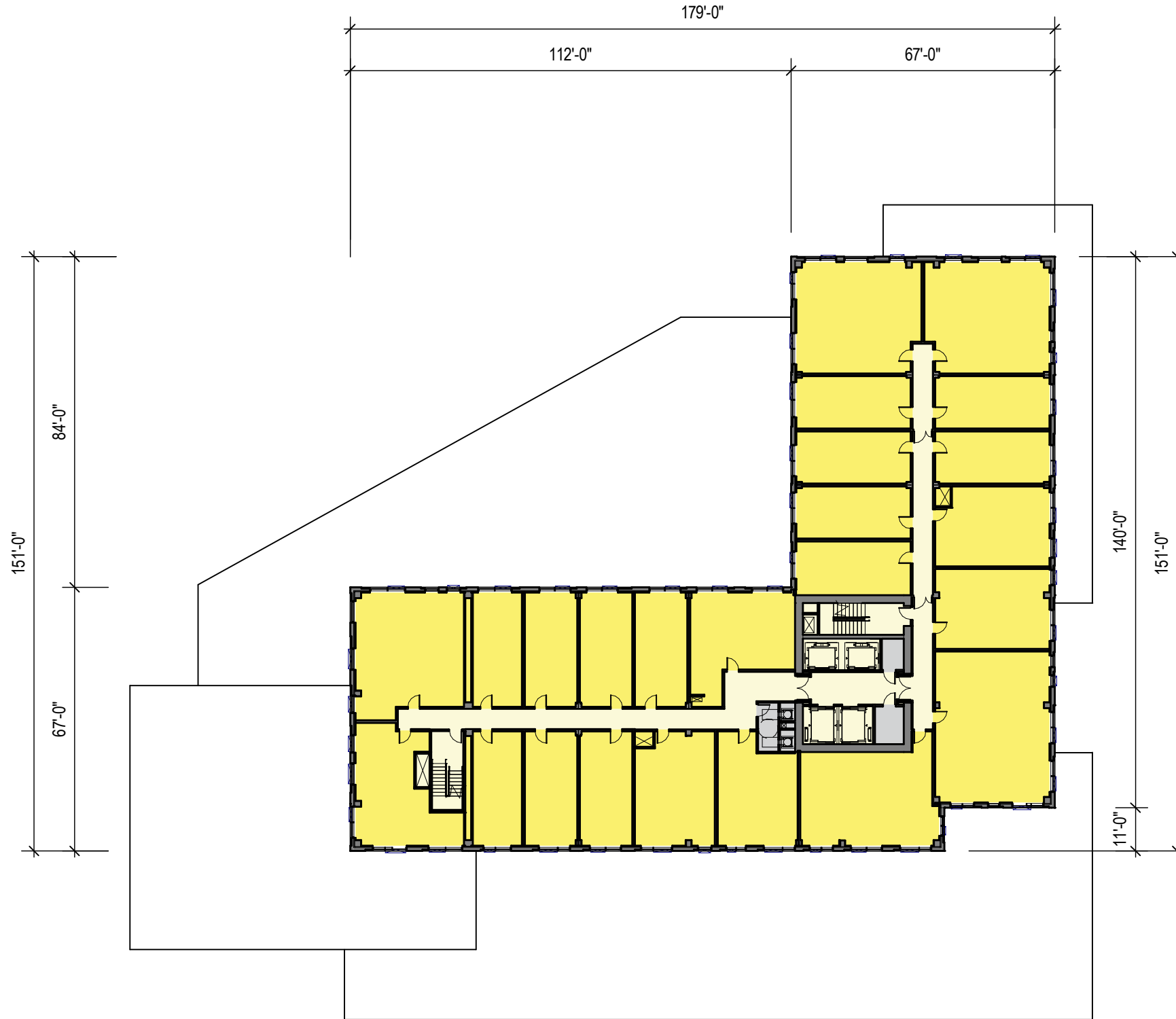

- RESIDENTIAL
- RES. CIRCULATION
- BOH / LOADING
- BIKE PARKING
- RETAIL



CAMBRIDGE CROSSING - PARCEL I
 PLAN - LEVELS 19-20

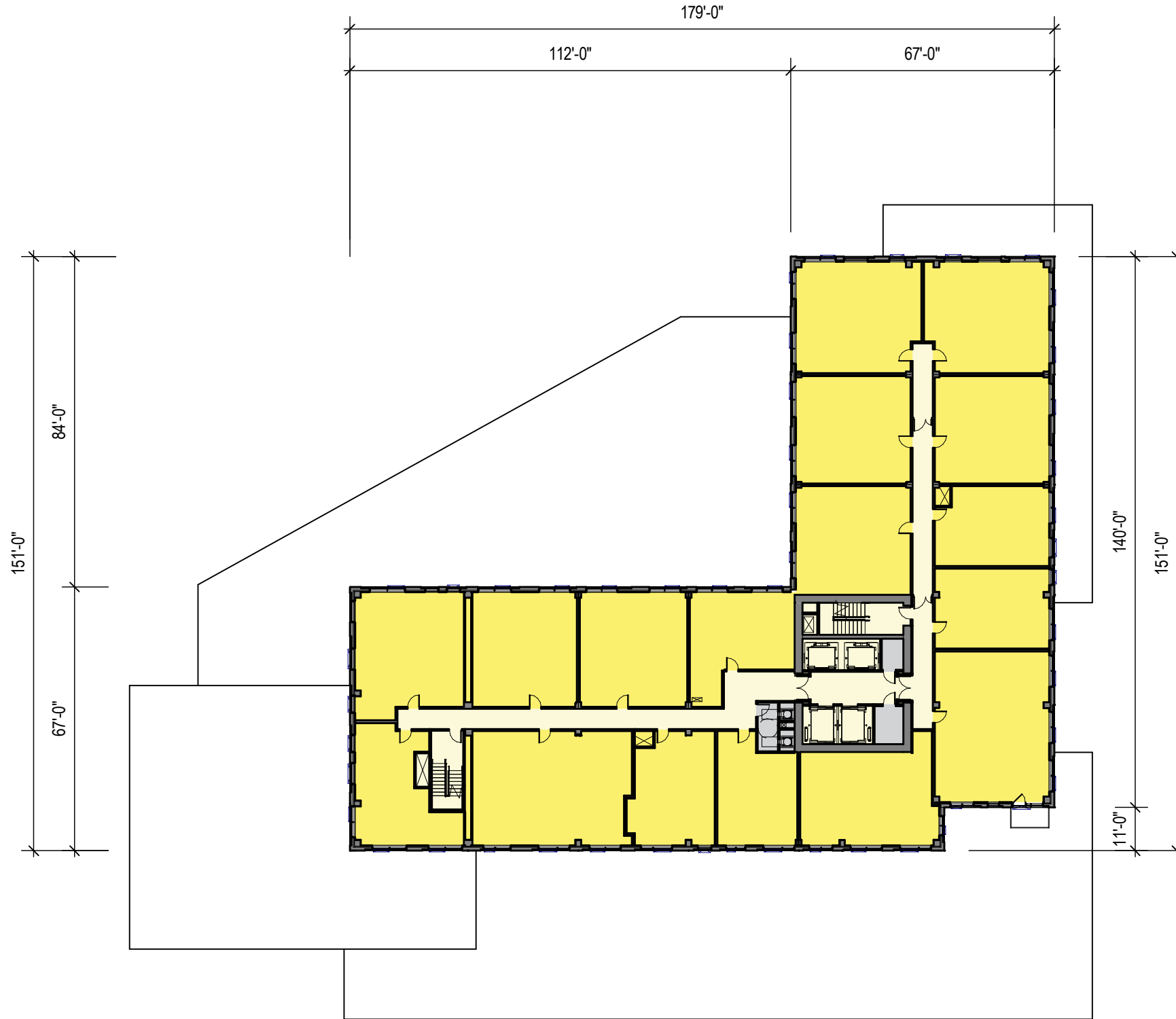

- RESIDENTIAL
- RES. CIRCULATION
- BOH / LOADING
- BIKE PARKING
- RETAIL



MICHAEL VAN VALKENBURGH ASSOCIATES INC



PLAN - ROOF

ROOFING SYSTEM 1 - HIGH ROOF

HIGH ALBEDO ADHERED MEMBRANE ROOFING SYSTEM

ROOFING SYSTEM 2 - GREEN ROOF

FUNCTIONAL GREEN ROOF SYSTEM - 2" MIN. PLANTING TRAYS AS DEFINED BY ARTICLE 22.30

ROOFING SYSTEM 3 - AMENITY DECK

LEED COMPLIANT (SRI) PAVER/PEDESTAL SYSTEM

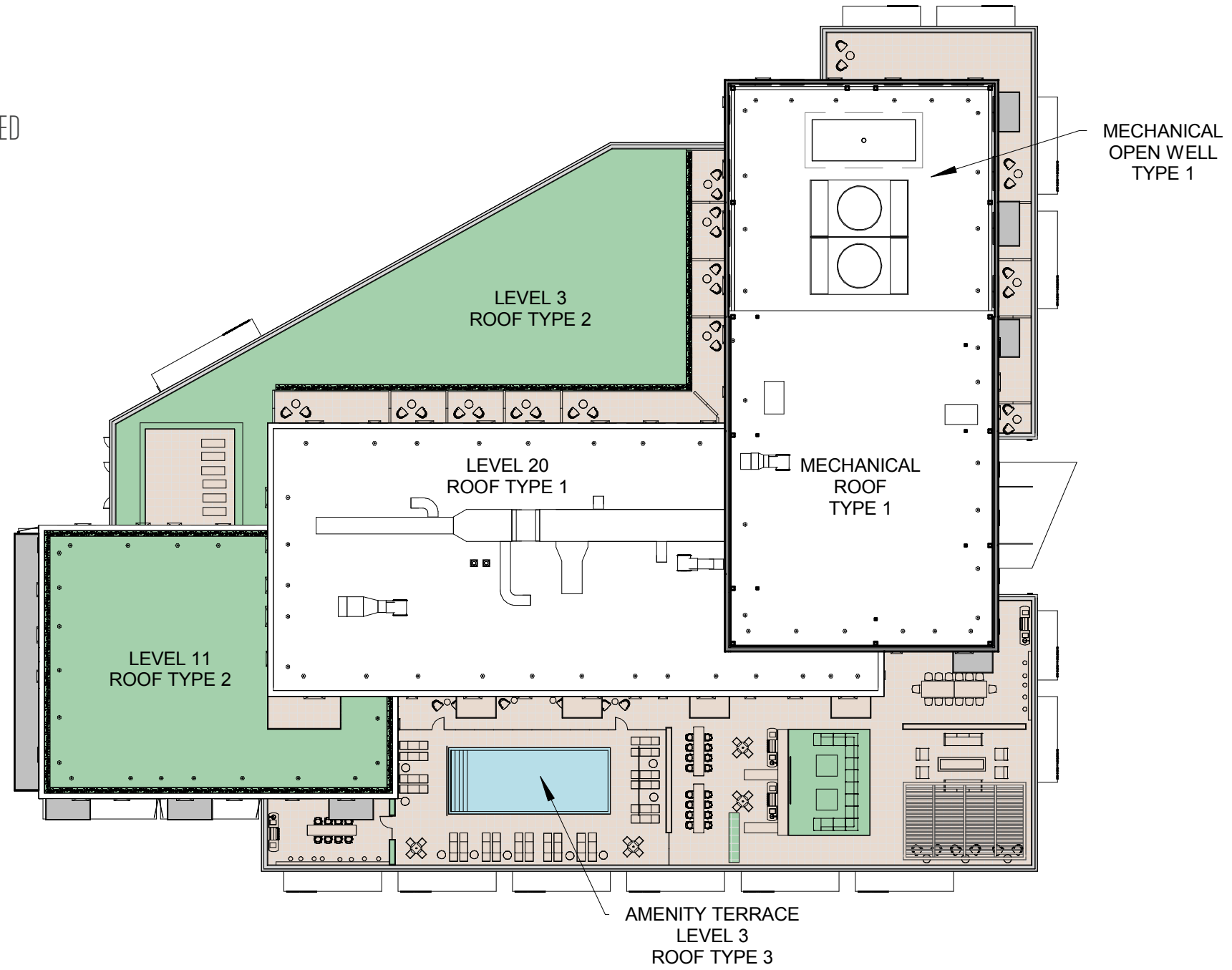

- RESIDENTIAL
- RES. CIRCULATION
- BOH / LOADING
- BIKE PARKING
- RETAIL

