

168 BRATTLE STREET
 CAMBRIDGE, MA
 AMENDED PROPOSAL

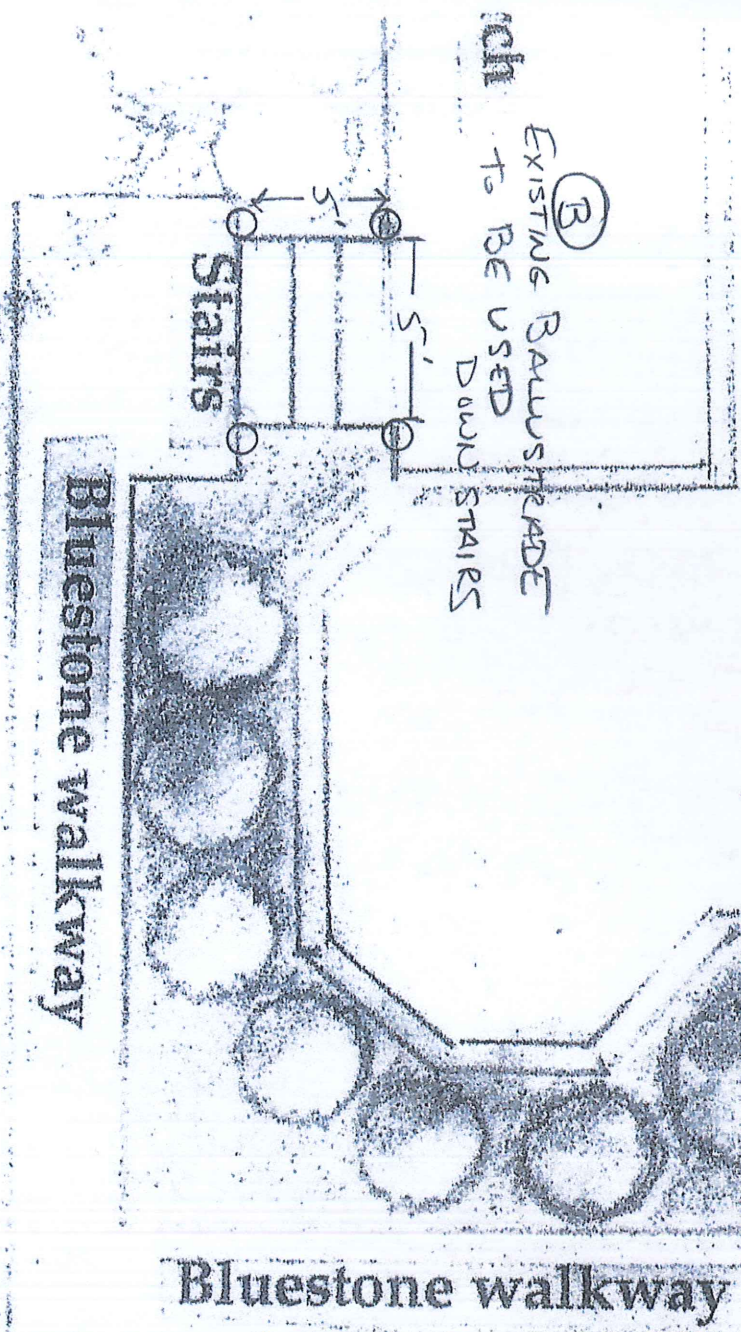

- ① REDUCE PROPOSED PORCH ADDITION
- ② ADD 2 STAIRCASES -
 - (A) 18" BEYOND EDGE OF DOOR
3' PORCH LANDING
2 STAIRS DOWN
 - (B) ADD 5' STAIR TO GARDEN LEVEL
- ③ CONNECT STAIR + PARKING W/ BLUESTONE WALKWAYS - ACCESS TO BRATTLE STREET DOOR

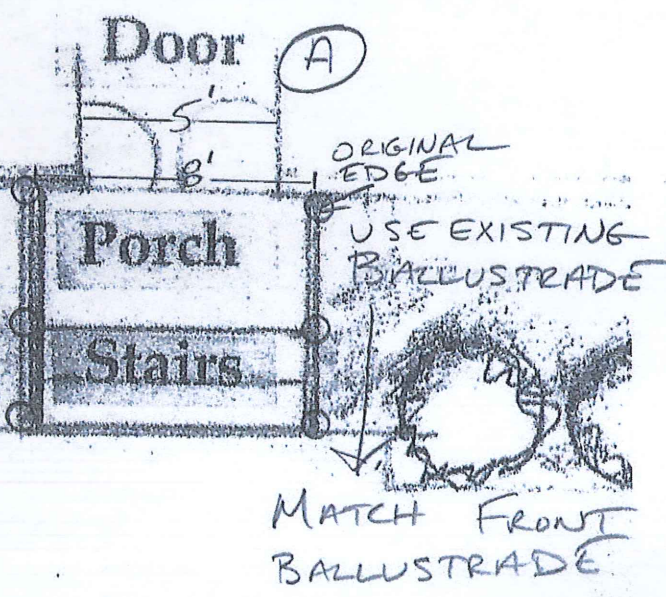

KUNG RESIDENCE
 DESIGN: SIRIUS LANDSCAPES, INC.

DETAIL

Brattle Street

Driveway

N

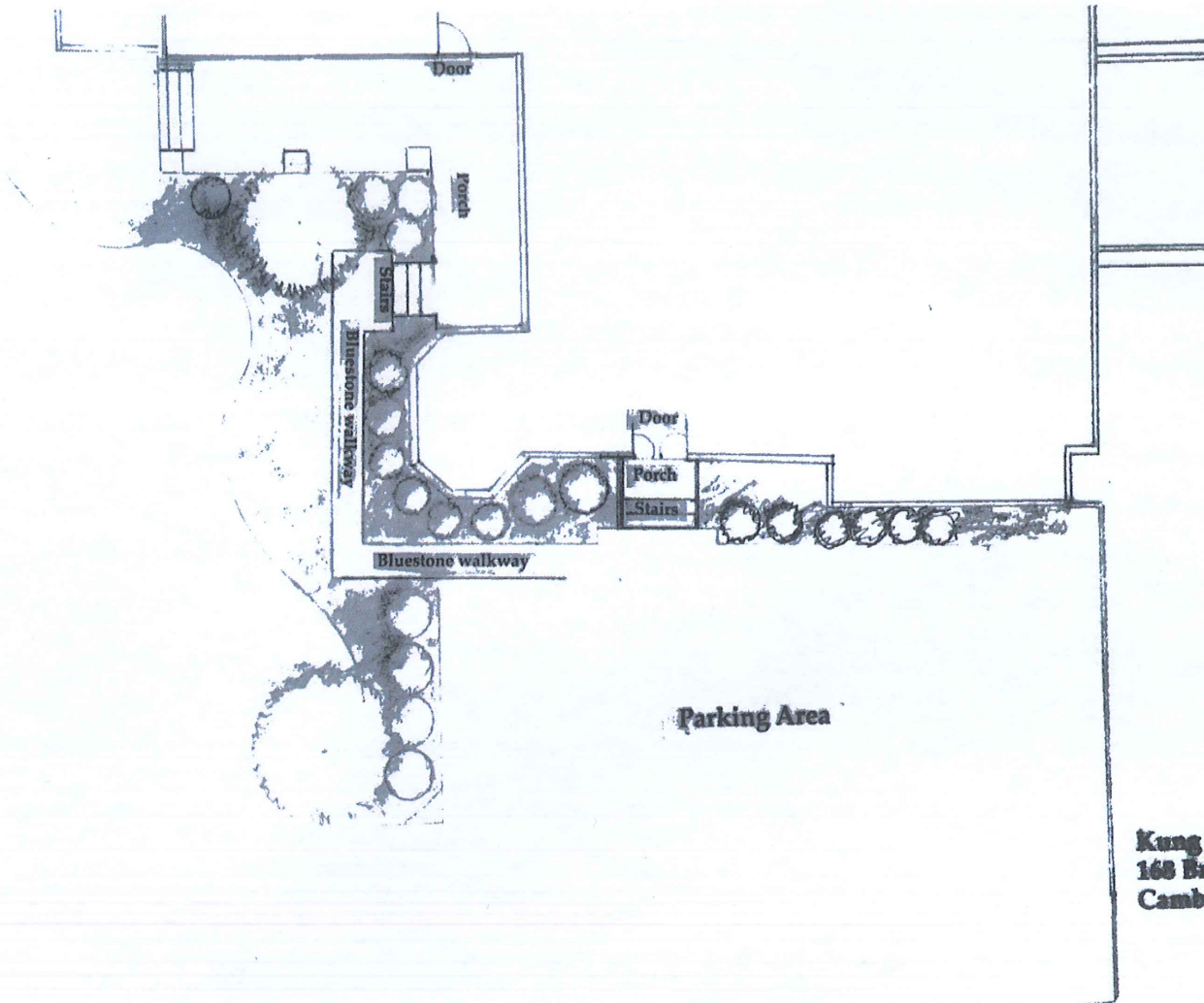

Kung Residence
168 Brattle Street
Cambridge MA

1/8" = 1'

Sirius Landscapes, Inc.

Images of railings

Susie Nacco <susie@siriuslandscapes.com>

Thu 4/2/2020 12:59 PM

To: Burks, Sarah <sburks@cambridgema.gov>

Hi Sarah,

These images are not perfect, nor have they been approved by Patricia, but they are along the line I am thinking.

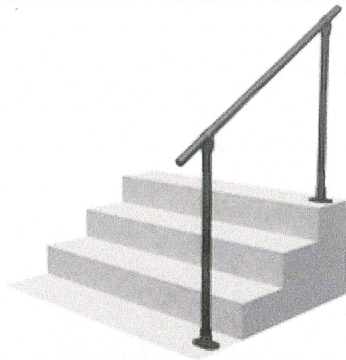

Thank you. See you later!

All the best

Susie Nacco

susie@siriuslandscapes.com

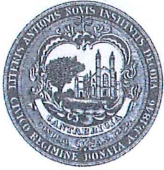

CAMBRIDGE HISTORICAL COMMISSION

831 Massachusetts Avenue, 2nd Fl., Cambridge, Massachusetts 02139

Telephone: 617 349 4683 Fax: 617 349 3116 TTY: 617 349 6112

E-mail: histcomm@cambridgema.gov URL: <http://www.cambridgema.gov/Historic>

Bruce A. Irving, *Chair*, Susannah Barton Tobin, *Vice Chair*; Charles M. Sullivan, *Executive Director*
William G. Barry, Jr., Robert G. Crocker, Joseph V. Ferrara, Chandra Harrington, Jo M. Solet, *Members*
Gavin W. Kleespies, Paula A. Paris, Kyle Sheffield, *Alternates*

CERTIFICATE OF APPROPRIATENESS

Property: 168 Brattle Street
Applicant: The Kung Family Trust
Attention: Patricia Yin Li Kung
168 Brattle Street
Cambridge, Mass. 02138

Cynthia Smith
Halvorson Design
25 Kingston Street
Boston, Mass. 02111

The Cambridge Historical Commission hereby certifies, pursuant to the Massachusetts Historic Districts Act (MGL Ch. 40C) and the Cambridge Historical Buildings and Landmarks Ordinance (Cambridge City Code, Ch. 2.78), that the work described below is not incongruous to the historic aspects or architectural character of the building or district:

1. Restore the existing porch and deck areas. Replace wood skirt at base, replicating existing details.
2. Construct an extension of the deck connecting the areas at the front of the house, around the Poet's Corner.
3. Restore grass strip along Brattle Street. Add two bluestone paths to the front and side entrances.
4. Repave driveway with dark colored exposed aggregate concrete pavement with snow melt system.
5. Pave parking court with dark colored exposed aggregate concrete. Install 5' high stockade fence and gate to match the design of the existing fence on the property. Construct walkway and stairs to north side entrance.
6. Remove paving, regrade and restore lawn in rear yard. Improve drainage and add a low granite seat wall.
7. Install bluestone patio, path and improve east entrance on east side of building.
8. Remove deck and replace with bluestone and stairs at rear yard.

9. Reconstruct the wood storage sheds and install bluestone path on east side yard.
10. Install low level lighting at driveway, parking court and limited stair entrance locations to replace existing lighting. Install tree lighting for 3-5 trees in the rear yard.

Work is to be carried out as indicated on the drawings by Halvorson Design Partnership titled, "Kung Residence 168 Brattle Street Cambridge MA," and dated June 18, 2019.

Approval was granted on the condition that construction details, including the fence and balustrade intersection, be reviewed and approved by CHC staff.

All improvements shall be carried out as shown on the plans and specifications submitted by the applicant, except as modified above. Approved plans and specifications are incorporated by reference into this certificate.

This certificate is granted upon the condition that the work authorized herein is commenced within six months after the date of issue. If the work authorized by this certificate is not commenced within six months after the date of issue, or if such work is suspended in significant part for a period of one year after the time the work is commenced, then this certificate shall expire and be of no further effect; provided that, for cause, one or more extensions of time, for periods not exceeding six months each, may be allowed in writing by the Chair.

Case Number: 4143

Date of Certificate: 10/15/19

Attest: A true and correct copy of decision filed with the offices of the City Clerk and the Cambridge Historical Commission on 10/15/19.

By Bruce A. Irving / slb, Chair.

Twenty days have elapsed since the filing of this decision.
No appeal has been filed _____. Appeal has been filed _____.
Date _____, City Clerk

Supplement

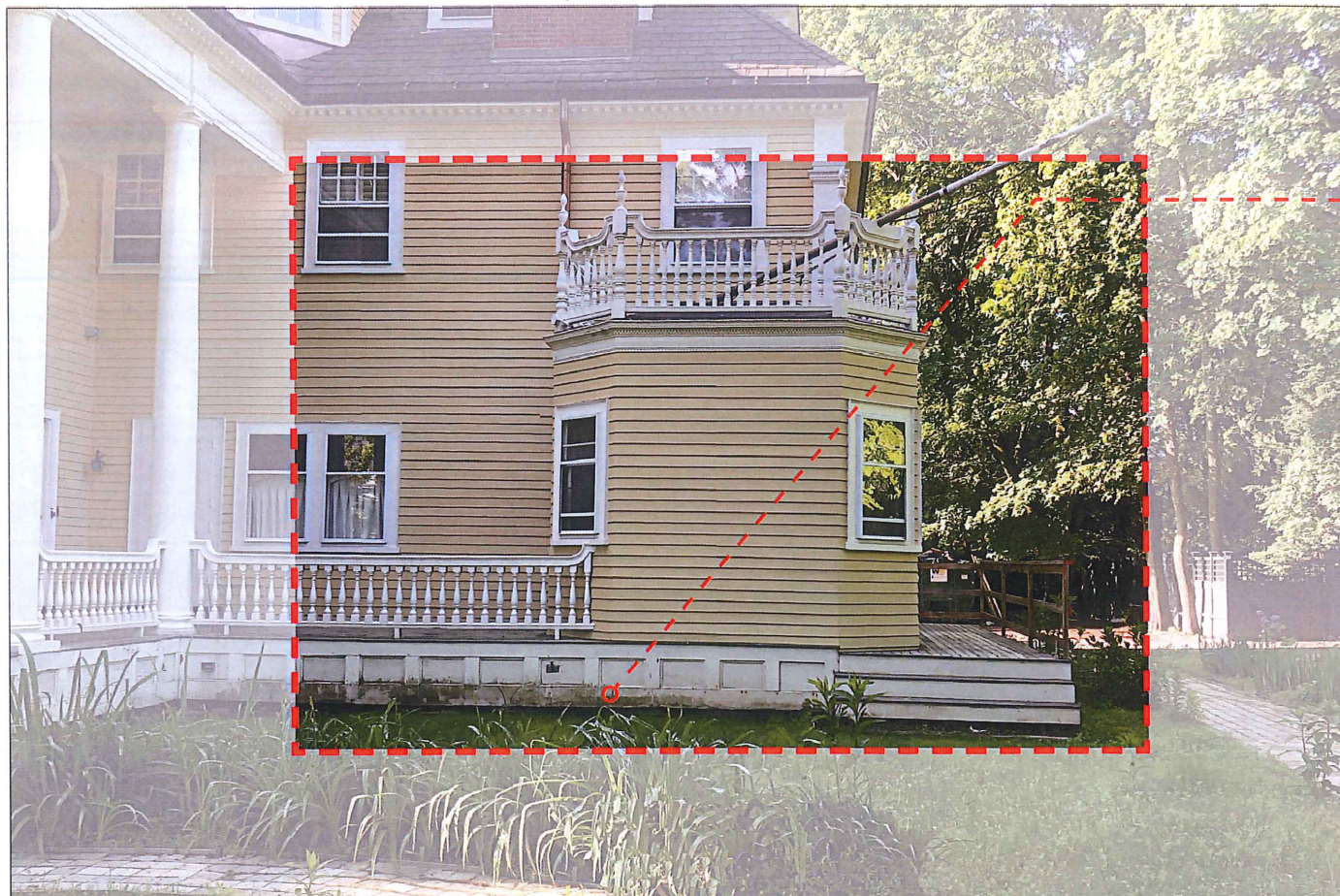

1 EXISTING CONDITION - VIEW FROM BRATTLE STREET
L6.0 SCALE: NTS

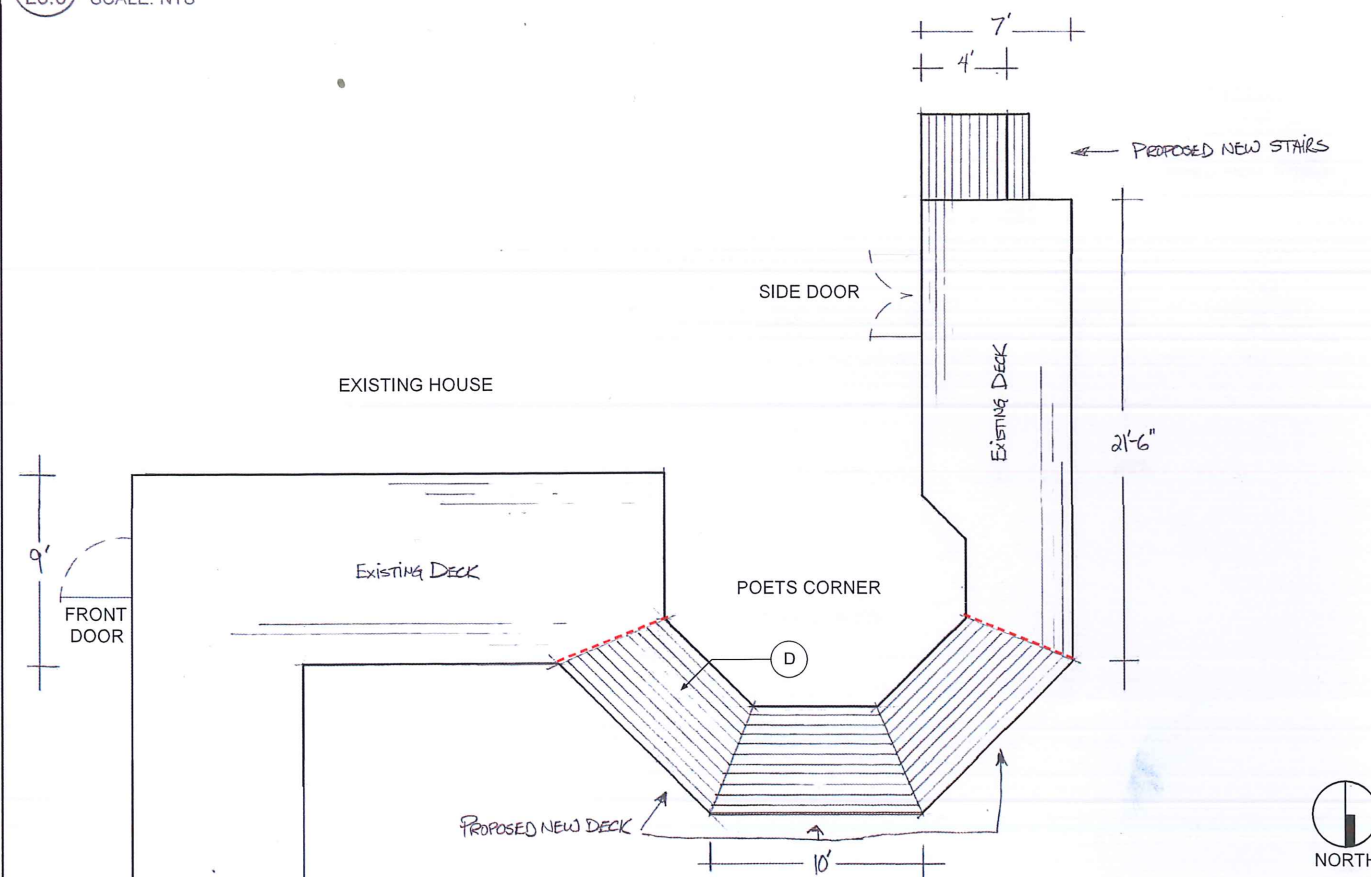

2 PROPOSED DECK PLAN / KEY PLAN
L6.0 SCALE: NTS

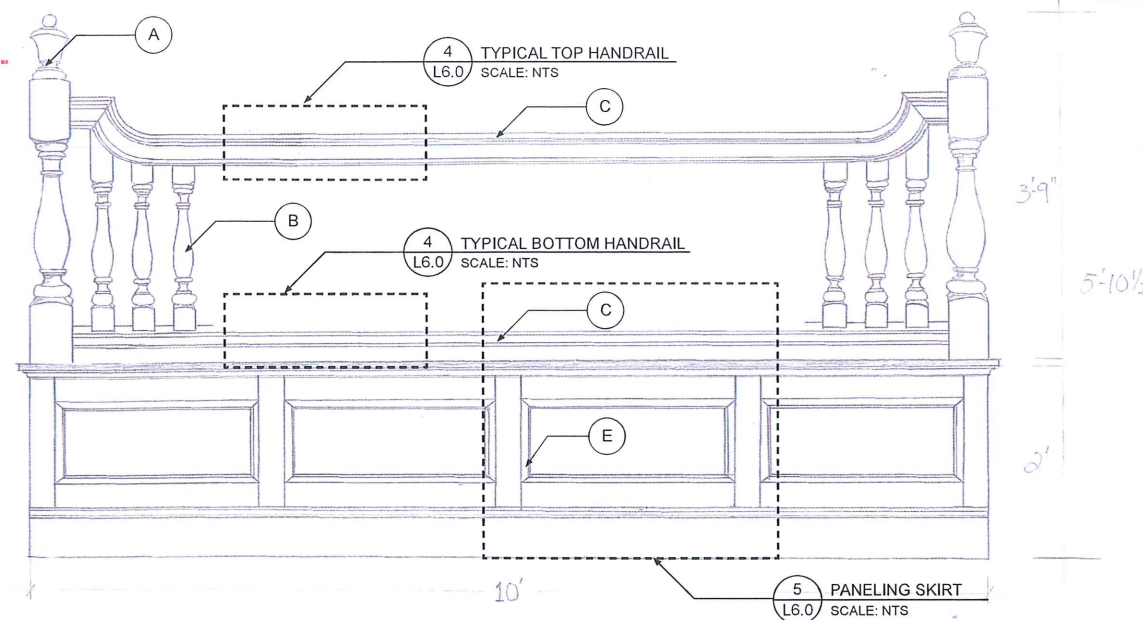

3 TYPICAL BALUSTER
L6.0 SCALE: NTS

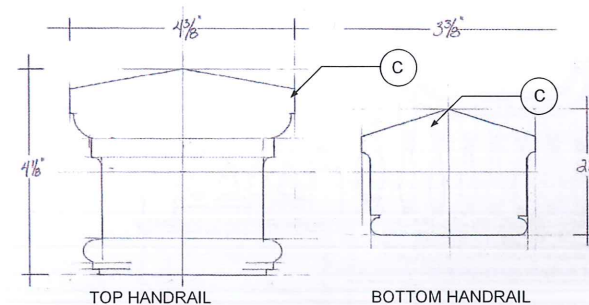

4 TYPICAL HANDRAILS
L6.0 SCALE: NTS

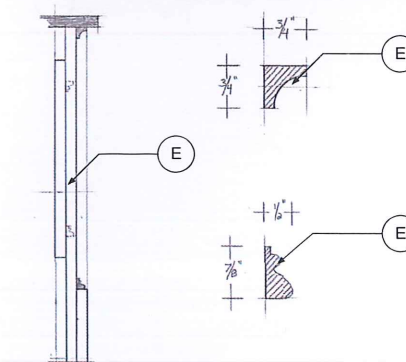

5 PANELING SKIRT
L6.0 SCALE: NTS

MATERIALS LEGEND:

TAG DETAIL DESCRIPTION

DECKING

- A 3/4" L6.0 NEWEL POSTS - WESTERN RED CEDAR
- B 3/4" L6.0 BALUSTERS - WESTERN RED CEDAR
- C 4" L6.0 HANDRAILS - WESTERN RED CEDAR / MAHOGANY
- D 2" L6.0 DECKING - 1 X 4" MAHOGANY
- E 5/8" L6.0 SKIRTS / PANELING - EASTERN WHITE PINE / MAHOGANY

NOTE(S):

- DECKING TO REMAIN NATURAL IN COLOR
- ALL PAINT TO MATCH EXISTING

HALVORSON DESIGN PARTNERSHIP

LANDSCAPE ARCHITECTS

Planned - Arden Restorations
1915 Planned - Arden East - Bridgewater, Ma
508-578-2438

KUNG RESIDENCE
168 BRATTLE ST
CAMBRIDGE, MA

HALVORSON DESIGN PARTNERSHIP

100 KINOSTON ST. BOSTON MA 02111-2808
PHONE: 617-552-2323
WWW.HALVORSONDESIGN.COM

168 BRATTLE ST.

CAMBRIDGE, MA

REVISIONS
JULY 02, 2019

RECEIVED

JUL 02 2019

CAMBRIDGE HISTORICAL COMMISSION

PROJECT NO: 19015
DRAWN BY: PC
CHECKED BY: CS
SCALE: 1/8"=1'-0"

CAMBRIDGE HISTORIC COMMISSION SUBMISSION

JUNE 18, 2019
DECK AND BALUSTER IMPROVEMENTS

L6.0



1 EXISTING CONDITION - SIDE PORCH
L6.0 SCALE: NTS

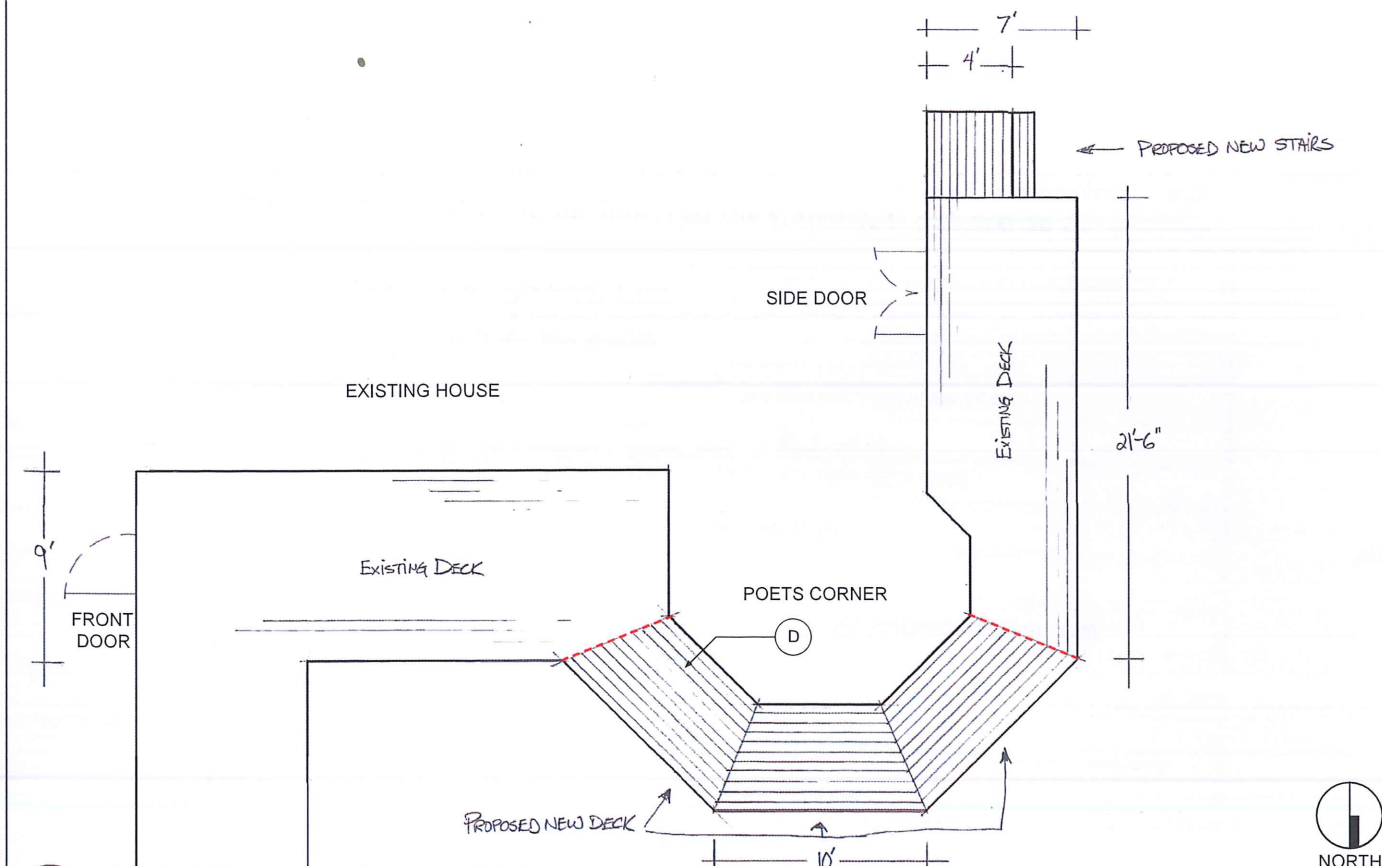

2 PROPOSED PLAN FOR DECK / KEY PLAN
L6.1 SCALE: NTS

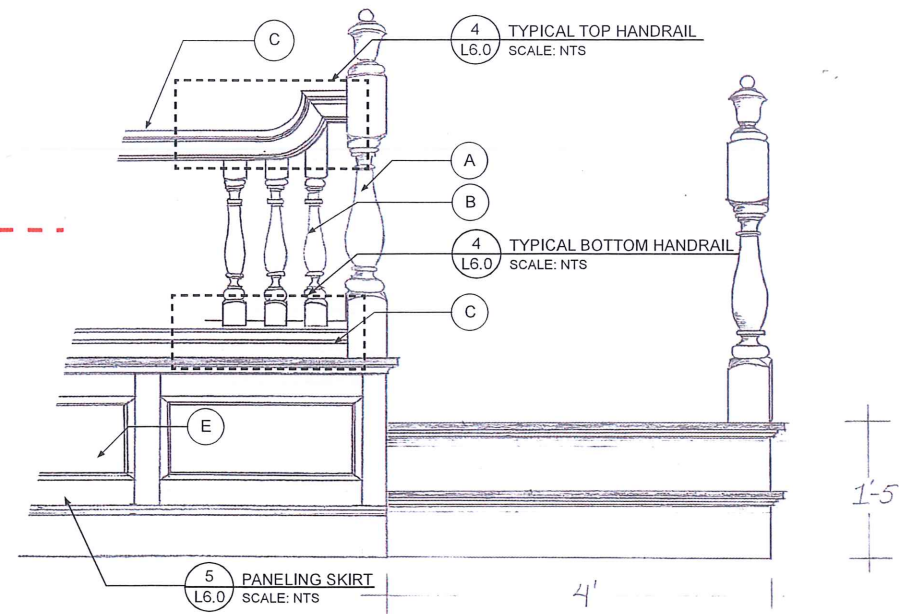

3 WEST ELEVATION
L6.1 SCALE: NTS

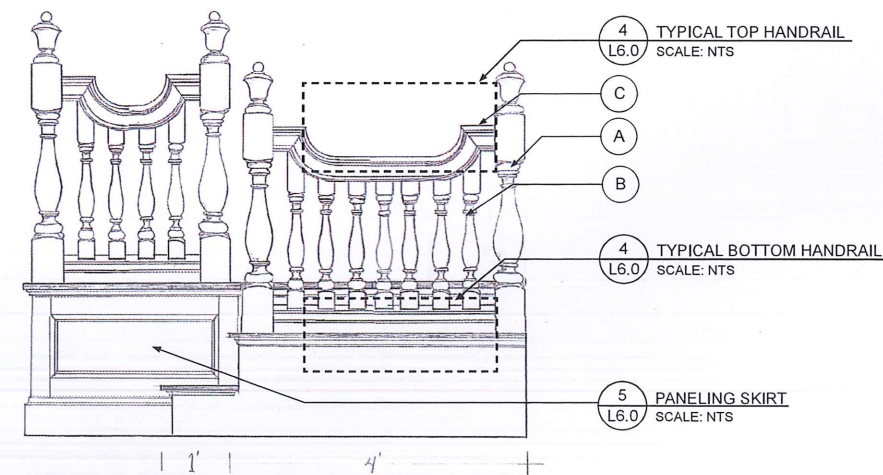

4 SOUTH ELEVATION
L6.1 SCALE: NTS

MATERIALS LEGEND:

TAG DETAIL DESCRIPTION

DECKING

- (A) 3/16.0 NEWEL POSTS - WESTERN RED CEDAR
- (B) 3/16.0 BALUSTERS - WESTERN RED CEDAR
- (C) 4/16.0 HANDRAILS - WESTERN RED CEDAR / MAHOGANY
- (D) 2/16.0 DECKING - 1 X 4" MAHOGANY
- (E) 5/16.0 SKIRTS / PANELING - EASTERN WHITE PINE / MAHOGANY

NOTE(S):

- DECKING TO REMAIN NATURAL IN COLOR
- ALL PAINT TO MATCH EXISTING

HALVORSON DESIGN PARTNERSHIP

LANDSCAPE ARCHITECTS

Planned Area Restorations
195 Planned Area East Bridgeport, Ma.
508-378-2433

KUNG RESIDENCE
168 BRATTLE ST
CAMBRIDGE, MA

HALVORSON DESIGN PARTNERSHIP

28 KENNEDY ST. SUITE 1000 MA 02111-2800
PHONE: 617-552-3333
WWW.HALVORSONDESIGN.COM

168 BRATTLE ST.

CAMBRIDGE, MA

REVISIONS
JULY 02, 2019

RECEIVED

JUL 02 2019

CAMBRIDGE HISTORICAL COMMISSION

PROJECT NO: 19015
DRAWN BY: PC
CHECKED BY: CS
SCALE: 1/8"=1'-0"

CAMBRIDGE HISTORIC COMMISSION SUBMISSION

JUNE 18, 2019

DECK AND BALUSTER IMPROVEMENTS

L6.1