

RIEDESEL AVENUE

Existing Conditions

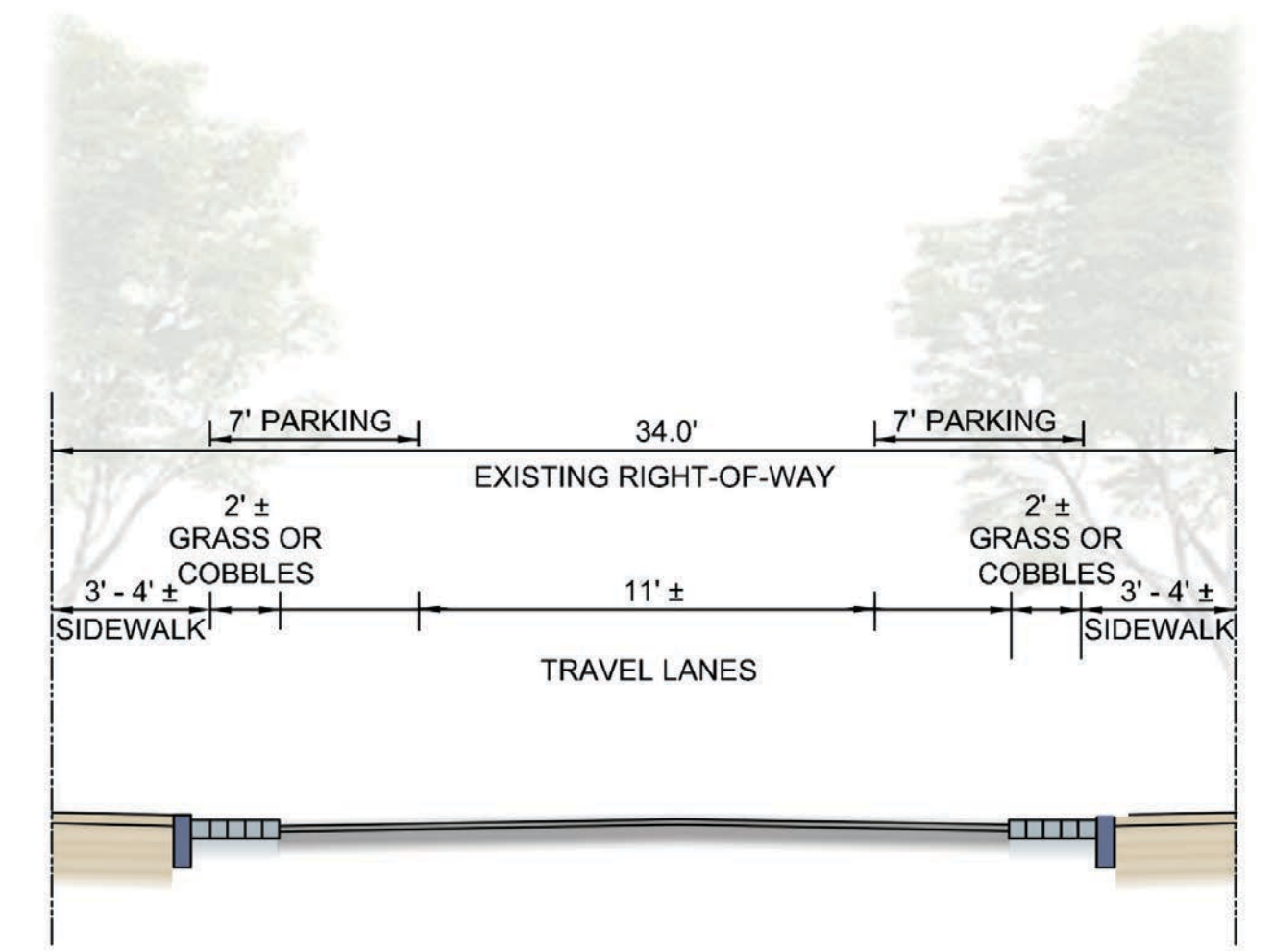

Typical Section

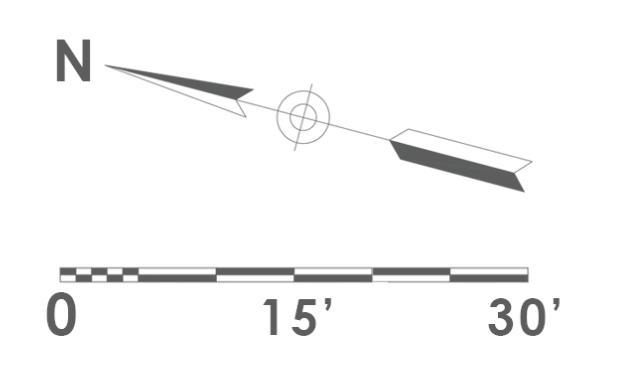
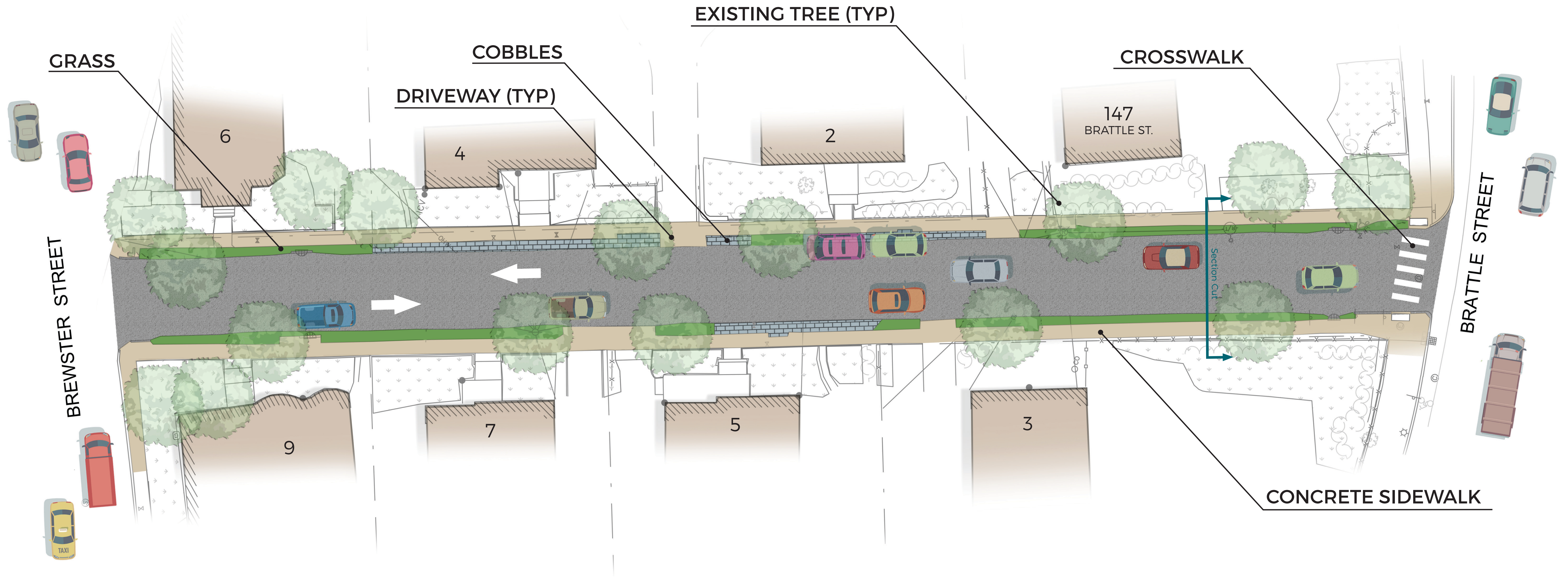

RIEDESEL AVENUE

Concept 1

**NOT FINAL DESIGN
FOR DISCUSSION ONLY**

Design Highlight

Concept 1

Fully Accessible Streets	✓
ADA Accessible Sidewalk(s)	
Raised Crosswalks at Intersections	✓
Mid-block Crosswalk for Accessibility	
Planting Opportunities (within 2' landscape area)	✓
Parking Maintained	✓
Cobbles within Parking Lane	✓

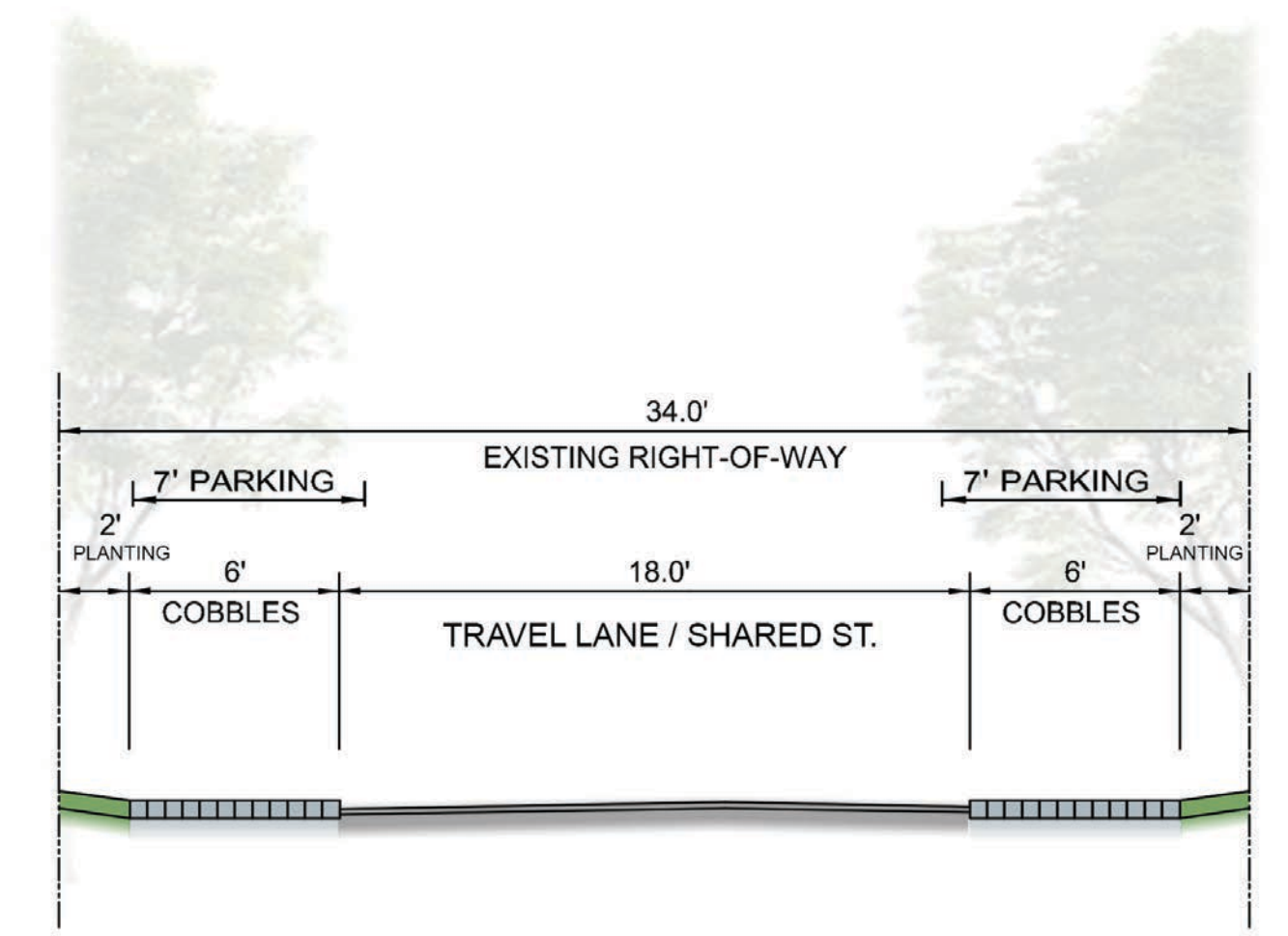

Typical Section

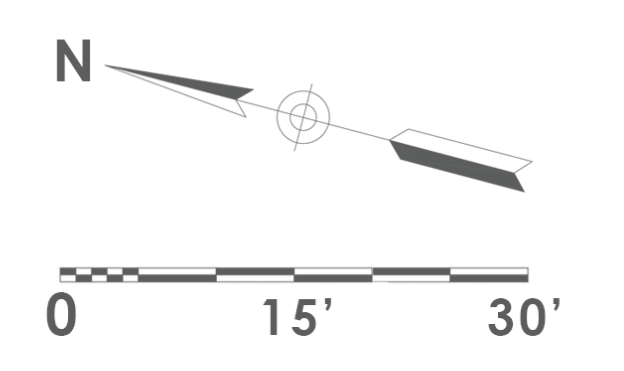
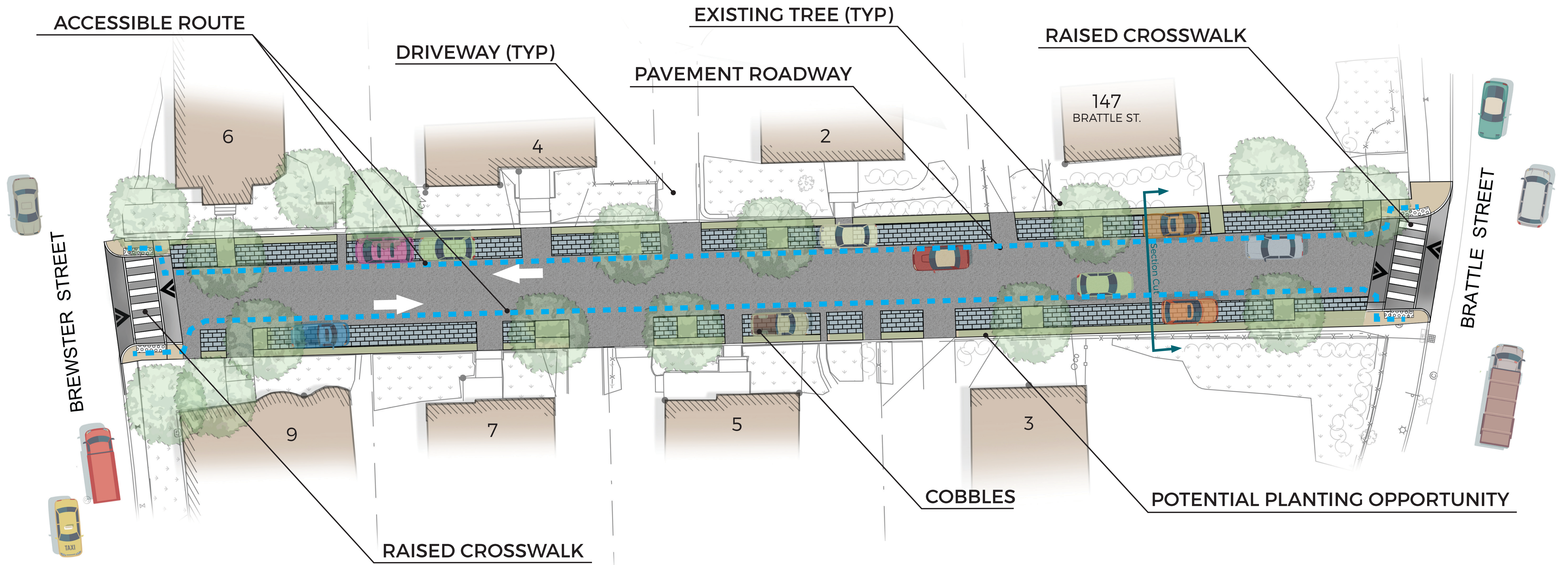

RIEDESEL AVENUE Concept 2

**NOT FINAL DESIGN
FOR DISCUSSION ONLY**

Design Highlight	Concept 2
Fully Accessible Streets	
ADA Accessible Sidewalk(s)	✓
Raised Crosswalks at Intersections	✓
Mid-block Crosswalk for Accessibility	
Planting Opportunities (within 2' landscape area)	✓
Parking Maintained	✓
Cobbles within Parking Lane	✓

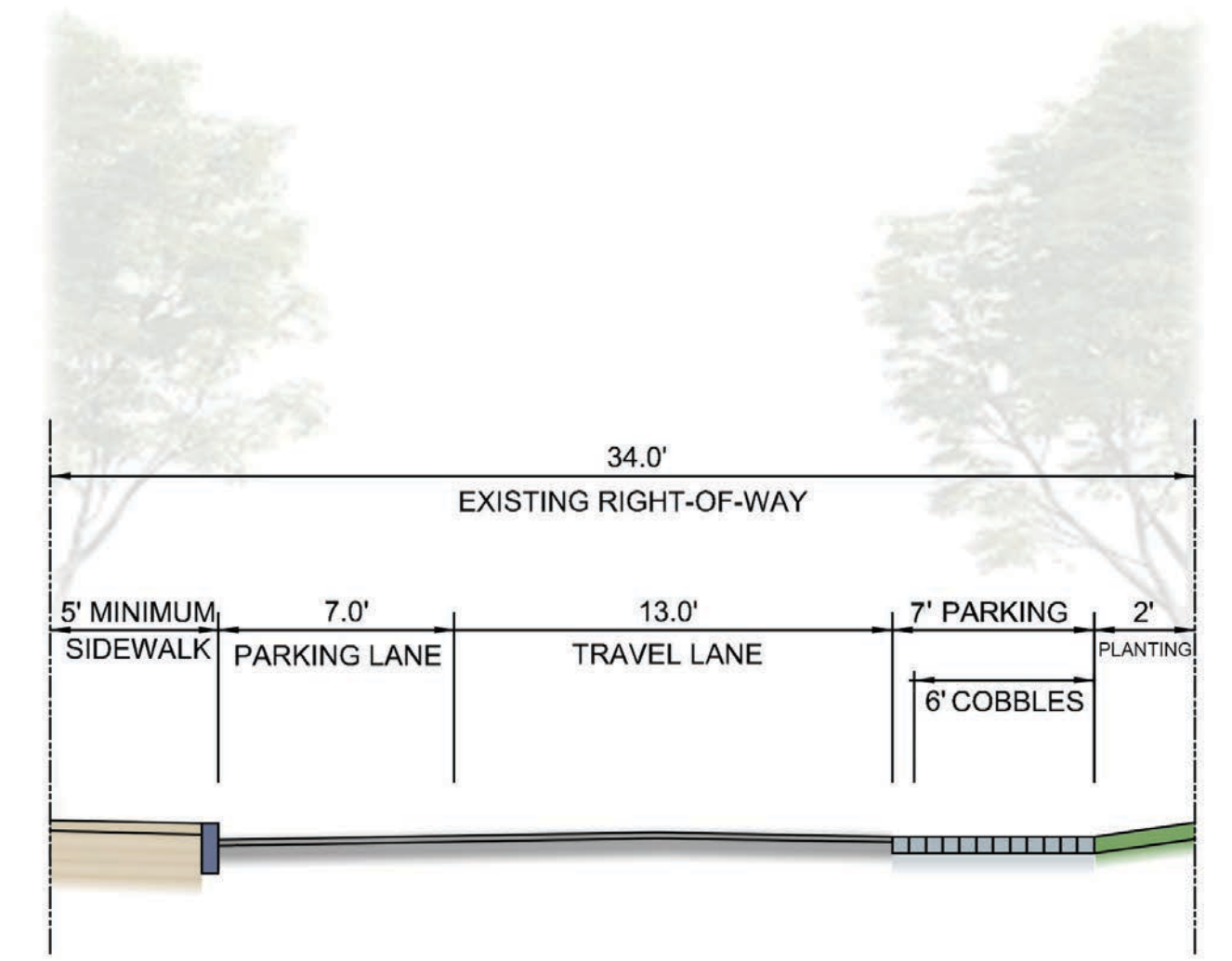

Typical Section

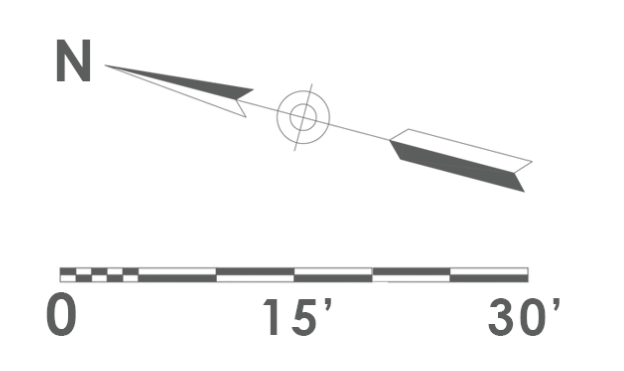
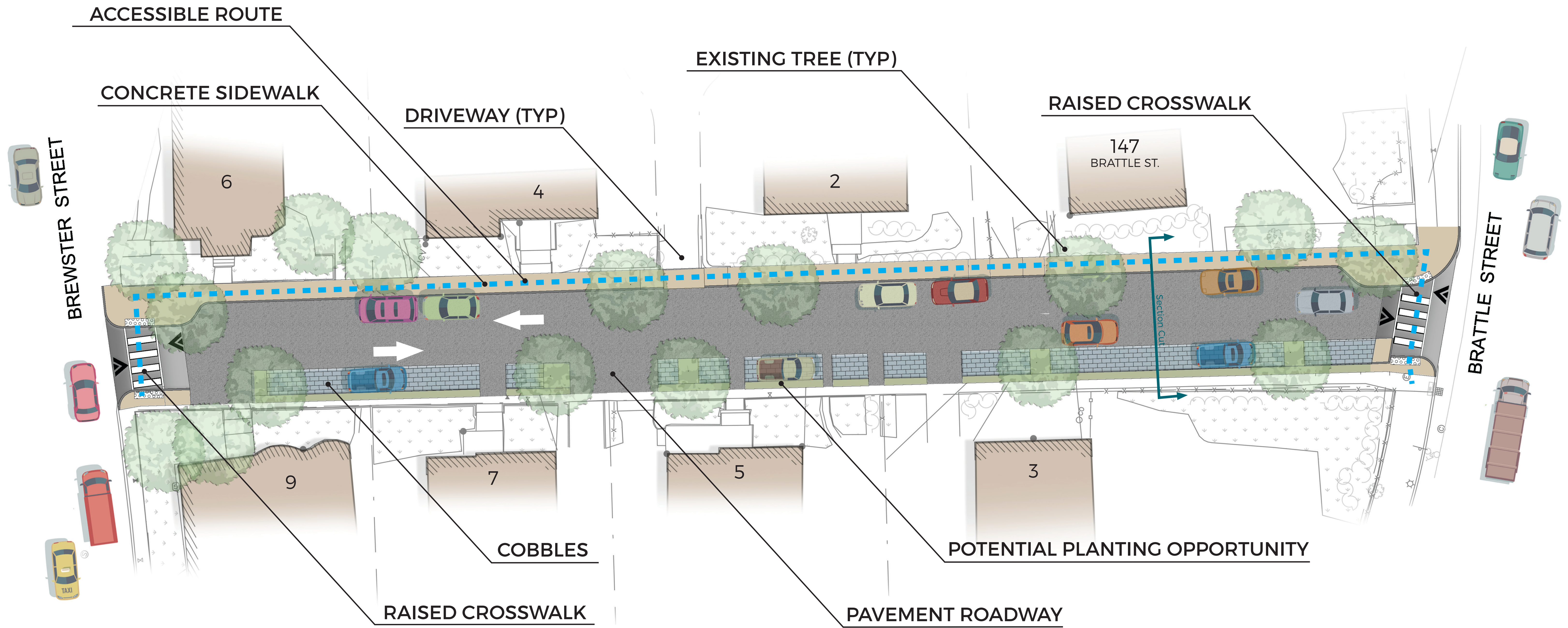

RIEDESEL AVENUE

Concept 3

**NOT FINAL DESIGN
FOR DISCUSSION ONLY**

Design Highlight

Concept 3

Fully Accessible Streets	
ADA Accessible Sidewalk(s)	✓
Raised Crosswalks at Intersections	✓
Mid-block Crosswalk for Accessibility	✓
Planting Opportunities (within 2' landscape area)	
Parking Maintained	✓
Cobbles within Parking Lane	✓

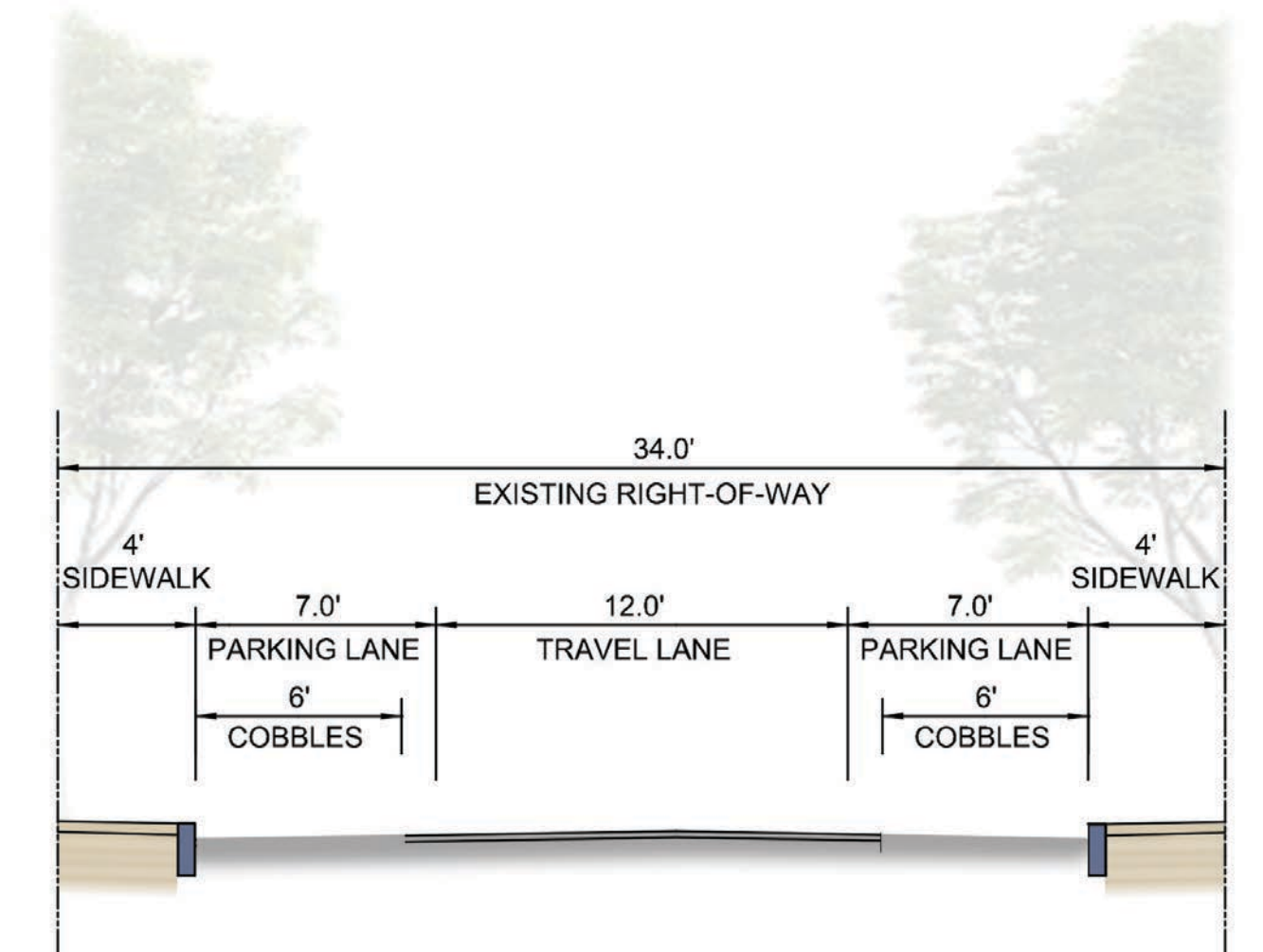

Typical Section

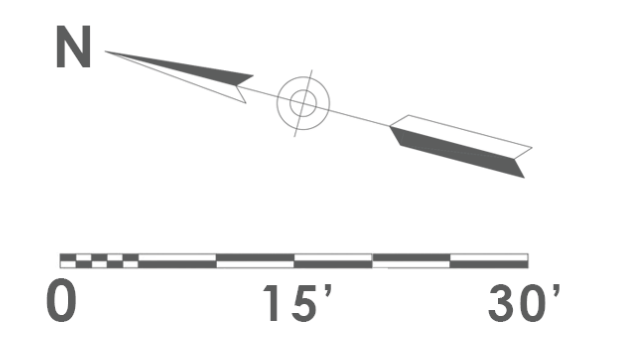
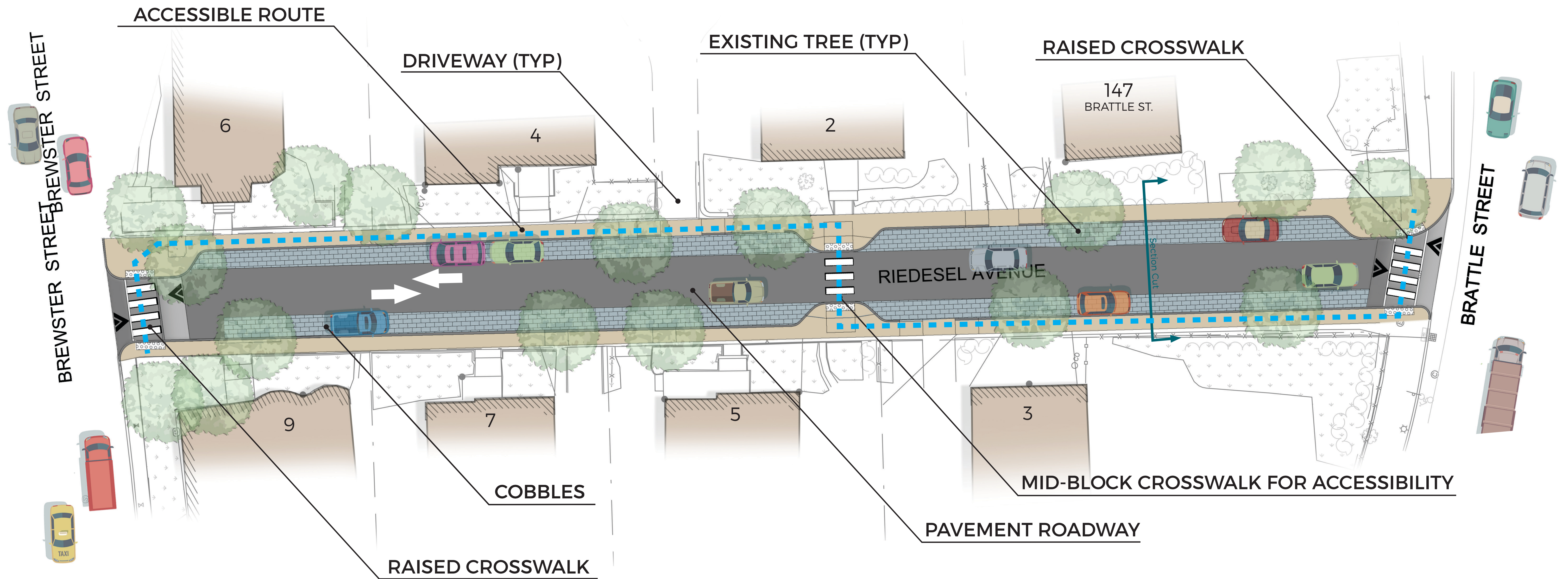

RIEDESEL AVENUE

Riedesel Avenue Concept Comparison

**NOT FINAL DESIGN
FOR DISCUSSION ONLY**

Design Highlight	Concept 1	Concept 2	Concept 3
Fully Accessible Streets	✓		
ADA Accessible Sidewalk(s)		✓	✓
Raised Crosswalks at Intersections	✓	✓	✓
Mid-block Crosswalk for Accessibility			✓
Planting Opportunities (within 2' landscape area)	✓	✓	
Parking Maintained	✓	✓	✓
Cobbles within Parking Lane	✓	✓	✓

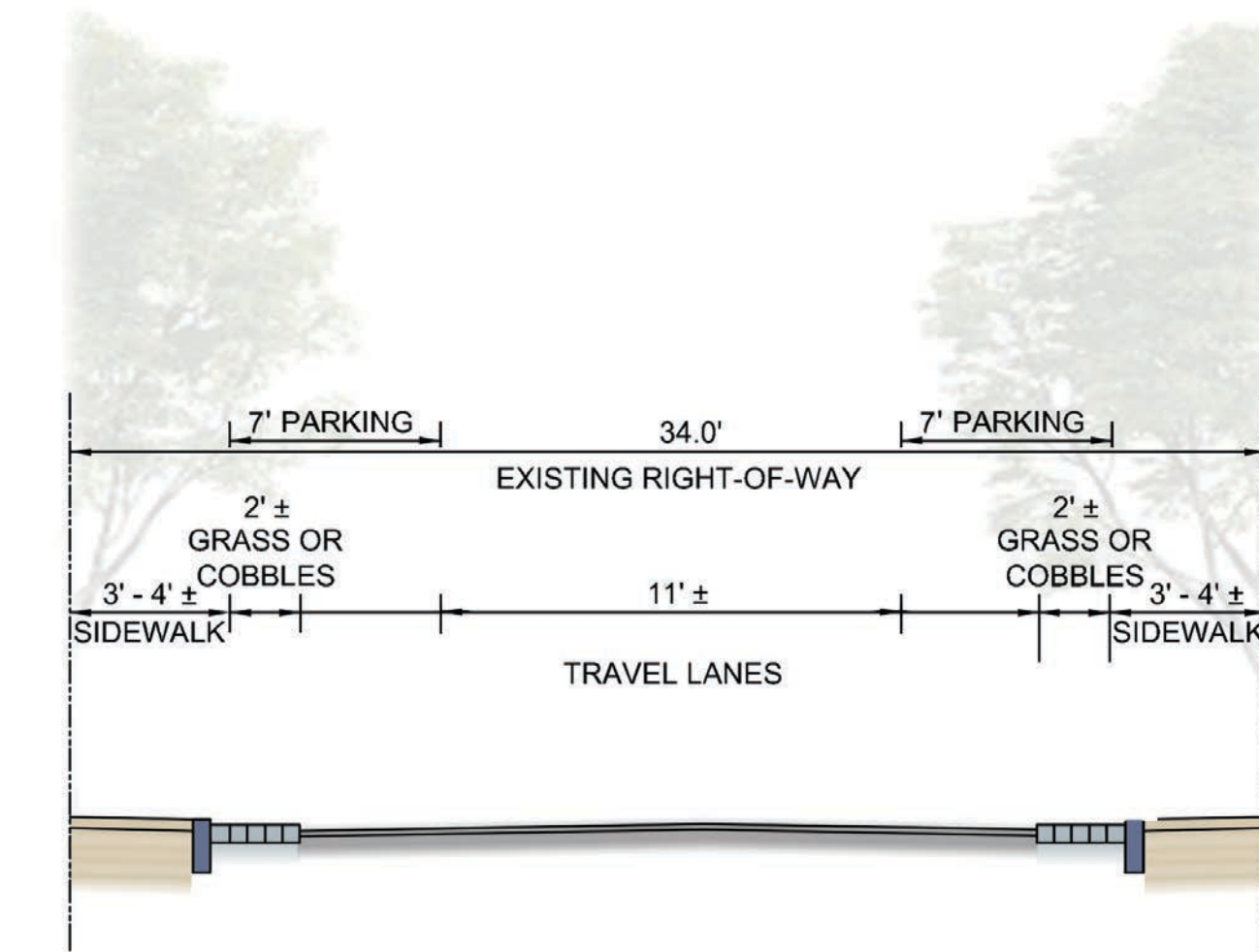

**Existing
Typical Section**

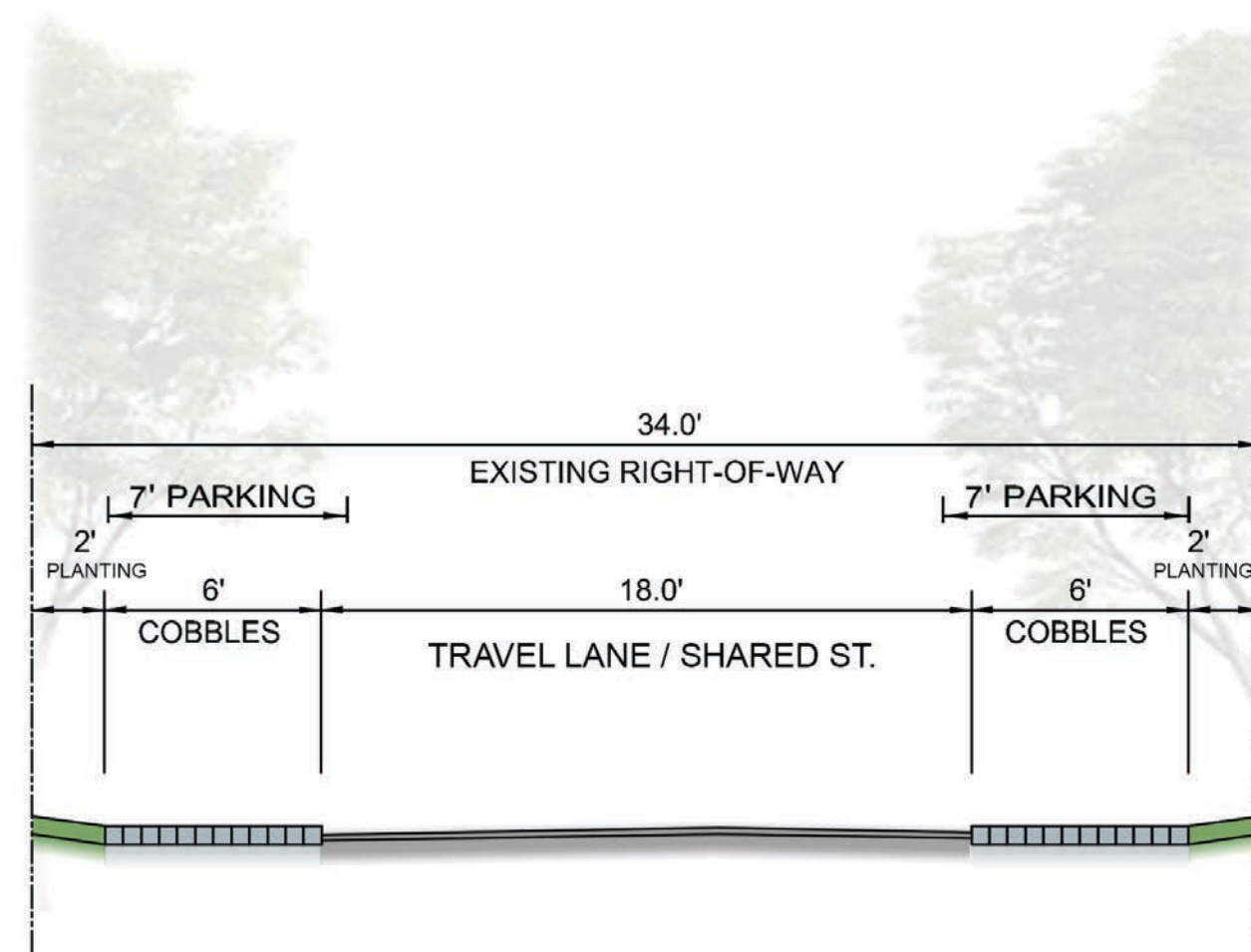

**Concept 1
Typical Section**

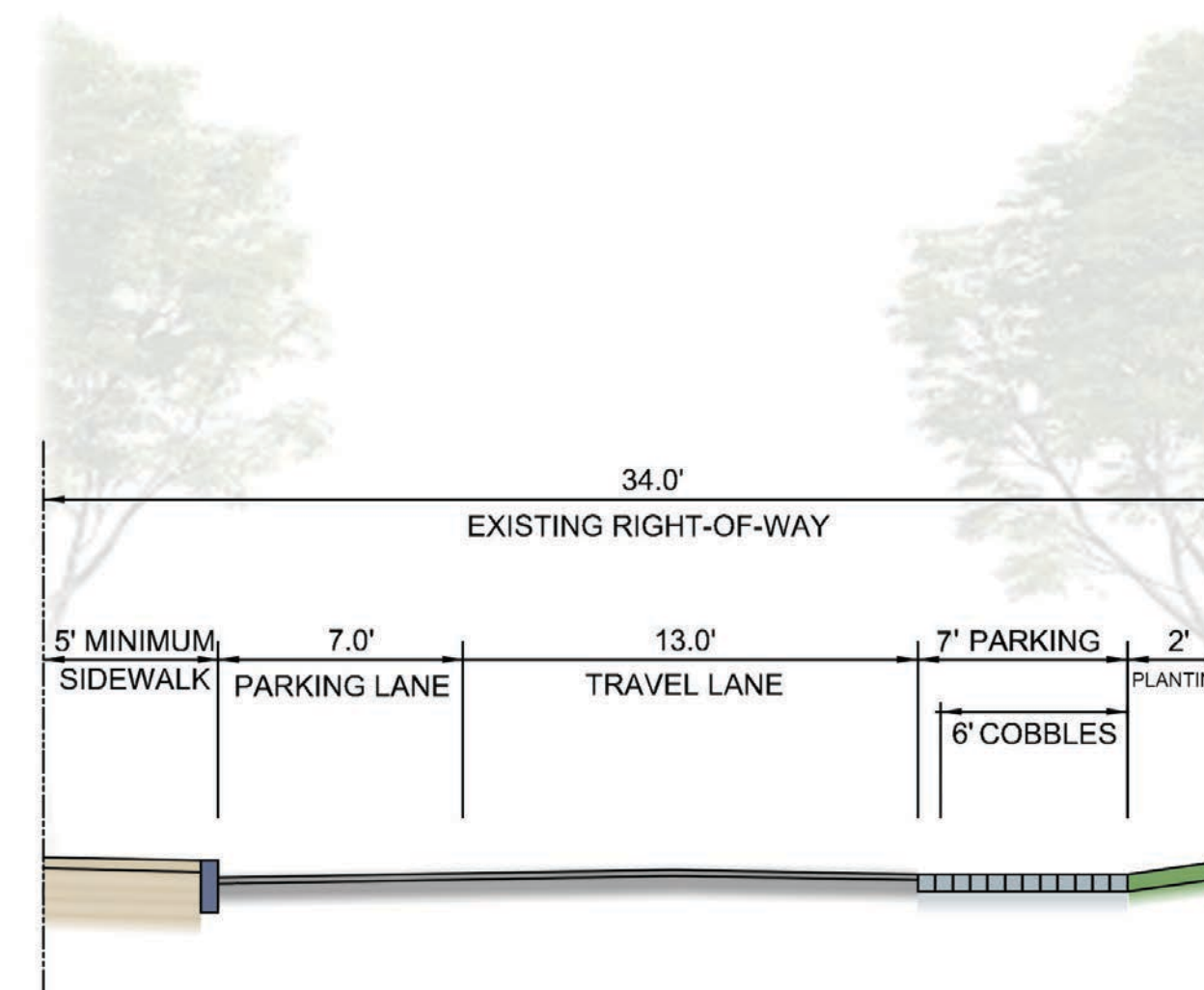

**Concept 2
Typical Section**

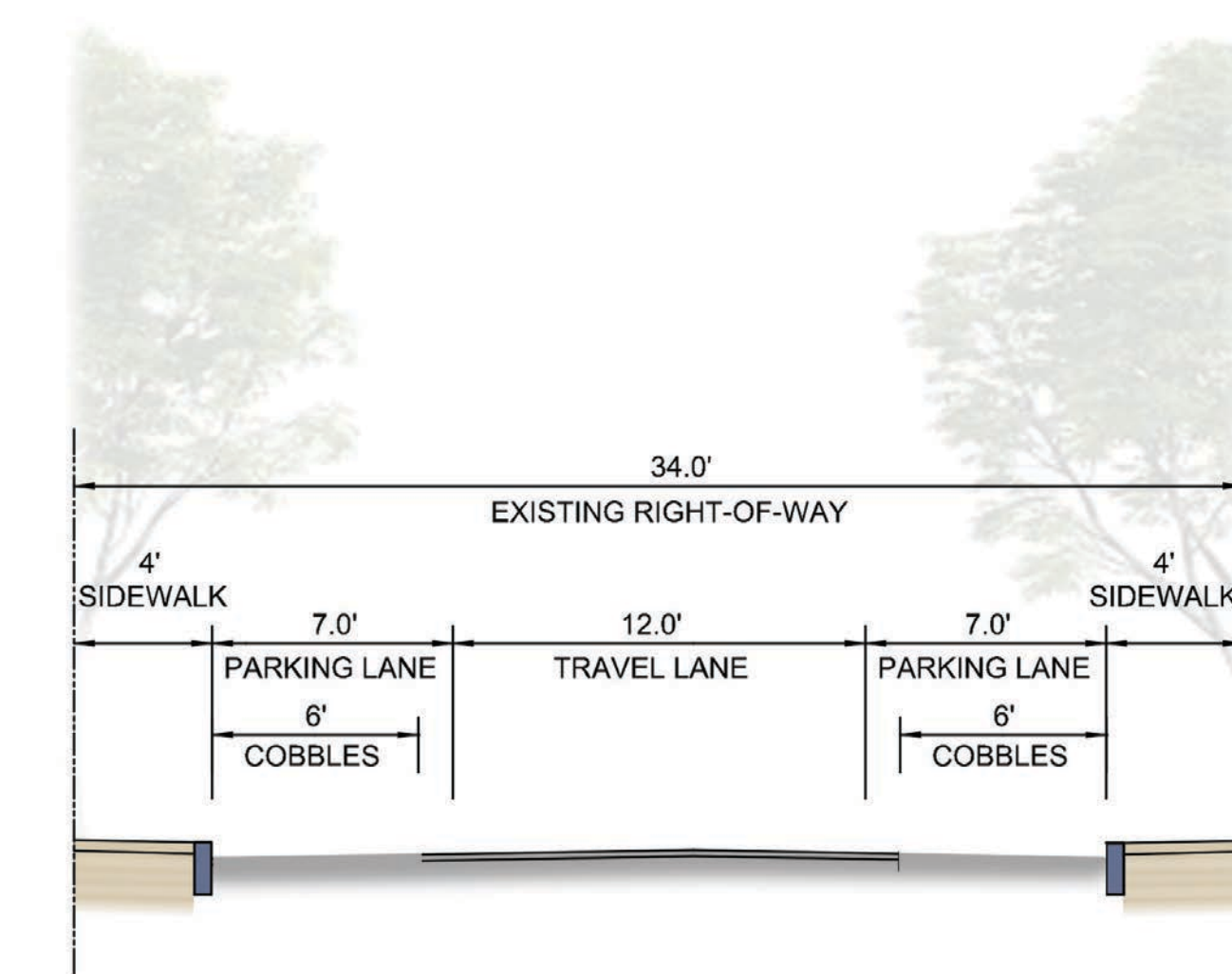

**Concept 3
Typical Section**