



CITY OF CAMBRIDGE

BOARD OF ZONING APPEAL

831 Massachusetts Avenue, Cambridge MA 02139

617-349-6100

BZA Application Form

BZA Number: 245889

General Information

The undersigned hereby petitions the Board of Zoning Appeal for the following:

Special Permit: _____ Variance: X Appeal: _____

PETITIONER: 3M J Realty C/O Morris Naggar

PETITIONER'S ADDRESS: 167 Bow Street, Suite 110, MA, Everett 02149

LOCATION OF PROPERTY: 585 Massachusetts Ave., Cambridge, MA

TYPE OF OCCUPANCY: Commercial **ZONING DISTRICT:** Business B Zone

REASON FOR PETITION:

/Sign/

DESCRIPTION OF PETITIONER'S PROPOSAL:

2 Banners 31.4 Sq ft, 31" x 146 on front of bulding on both sides of windows

SECTIONS OF ZONING ORDINANCE CITED:

Article: 7.000 Section: 7.16.22.D (Business Sign).

Article: 10.000 Section: 10.30 (Variance).

Original
Signature(s):



(Petitioner (s) / Owner)

Joseph M Naggar

(Print Name)

Address: _____
Tel. No. _____
E-Mail Address: Janice@ardonvisual.com

2023 NOV -3 AM 10:56
OFFICE OF THE CITY CLERK
CAMBRIDGE, MASSACHUSETTS

BZA APPLICATION FORM - OWNERSHIP INFORMATION

To be completed by OWNER, signed before a notary and returned to The Secretary of the Board of Zoning Appeals.

I/We Joseph M Naggar (OWNER)

Address: 585 Massachusetts Ave, Cambridge MA 02139

State that I/We own the property located at 585 Massachusetts Ave, which is the subject of this zoning application.

The record title of this property is in the name of 3MJ Associates LLC

*Pursuant to a deed of duly recorded in the date 8/1/05, Middlesex South County Registry of Deeds at Book 45765, Page 147; or Middlesex Registry District of Land Court, Certificate No. _____ Book _____ Page _____.

SIGNATURE BY LAND OWNER OR AUTHORIZED TRUSTEE, OFFICER OR AGENT*

*Written evidence of Agent's standing to represent petitioner may be requested.

Commonwealth of Massachusetts, County of Middlesex

The above-name Joseph M. Naggar personally appeared before me, this 26 of October, 2023, and made oath that the above statement is true.

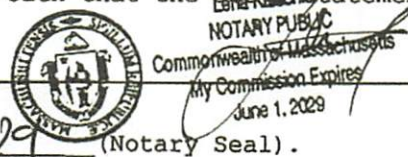
 Notary

My commission expires June 1, 2029 (Notary Seal).

- If ownership is not shown in recorded deed, e.g. if by court order, recent deed, or inheritance, please include documentation.

PROPERTY OWNER'S LETTER OF AUTHORIZATION

April 27, 2023

City of Cambridge
795 Massachusetts Avenue
Cambridge, MA 02139

RE: Dimagi

To Whom It May Concern:

I Morris M. Naggar of 585 Massachusetts Avenue, Cambridge, MA
02139 owner of said

property, hereby authorize the above-referenced tenant to obtain new/and or change existing
signage at the above-referenced address.

I also authorize Ardon Visual Communications and its employees of Woburn, MA 01801 to
obtain the required and necessary permits, licenses, and approvals, which may be required for
the installation of said signage and proceed with the installation if in accordance with all the
governing laws, statues, and ordinances.

Signature: M. M. Naggar

Printed: Morris M. Naggar

Telephone: (617) 549-0070

E-mail: Morris@3MJrealty.com



Lena Kalachian
NOTARY PUBLIC
Commonwealth of Massachusetts
My Commission Expires
June 1, 2029

BZA Application Form

SUPPORTING STATEMENT FOR A VARIANCE

EACH OF THE FOLLOWING REQUIREMENTS FOR A VARIANCE MUST BE ESTABLISHED AND SET FORTH IN COMPLETE DETAIL BY THE APPLICANT IN ACCORDANCE WITH MGL 40A, SECTION 10.

- A)** A literal enforcement of the provisions of this Ordinance would involve a substantial hardship, financial or otherwise, to the petitioner or appellant for the following reasons:
- Unknown
- B)** The hardship is owing to the following circumstances relating to the soil conditions, shape or topography of such land or structures and especially affecting such land or structures but not affecting generally the zoning district in which it is located for the following reasons:
- Unknown
- C) DESIRABLE RELIEF MAY BE GRANTED WITHOUT EITHER:**
- 1)** Desirable relief may be granted without substantial detriment to the public good for the following reasons:
- NA
- 2)** Desirable relief may be granted without nullifying or substantially derogating from the intent or purpose of this Ordinance for the following reasons:
- NA

***If you have any questions as to whether you can establish all of the applicable legal requirements, you should consult with an attorney.**

Date: _____

BZA Application Form

DIMENSIONAL INFORMATION

Applicant: 3M J Realty
Location: 585 Massachusetts Ave., Cambridge, MA
Phone:

Present Use/Occupancy: Commercial
Zone: Business B Zone
Requested Use/Occupancy: Commercial

		<u>Existing Conditions</u>	<u>Requested Conditions</u>	<u>Ordinance Requirements</u>	
<u>TOTAL GROSS FLOOR AREA:</u>		NA	NA	NA	(max.)
<u>LOT AREA:</u>		NA	N/A	N/A	(min.)
<u>RATIO OF GROSS FLOOR AREA TO LOT AREA: ²</u>		1.73	NA	NA	
<u>LOT AREA OF EACH DWELLING UNIT</u>		5,463	NA	NA	
<u>SIZE OF LOT:</u>	WIDTH	NA	NA	NA	
	DEPTH	81x92	NA	NA	
<u>SETBACKS IN FEET:</u>	FRONT	NA	NA	NA	
	REAR	NA	NA	NA	
	LEFT SIDE	N	NA	NA	
	RIGHT SIDE	NA	NA	NA	
<u>SIZE OF BUILDING:</u>	HEIGHT	42	NA	NA	
	WIDTH	NA	NA	NA	
	LENGTH	NA	NA	NA	
<u>RATIO OF USABLE OPEN SPACE TO LOT AREA:</u>		N	NA	NA	
<u>NO. OF DWELLING UNITS:</u>		Unknown	NA	NA	
<u>NO. OF PARKING SPACES:</u>		Unknown	None	NA	
<u>NO. OF LOADING AREAS:</u>		None	None	NA	
<u>DISTANCE TO NEAREST BLDG. ON SAME LOT</u>		Unknown	NA	NA	

Describe where applicable, other occupancies on the same lot, the size of adjacent buildings on same lot, and type of construction proposed, e.g; wood frame, concrete, brick, steel, etc.:

NA

1. SEE CAMBRIDGE ZONING ORDINANCE ARTICLE 5.000, SECTION 5.30 (DISTRICT OF DIMENSIONAL REGULATIONS).
2. TOTAL GROSS FLOOR AREA (INCLUDING BASEMENT 7'-0" IN HEIGHT AND ATTIC AREAS GREATER THAN 5') DIVIDED BY LOT AREA.
3. OPEN SPACE SHALL NOT INCLUDE PARKING AREAS, WALKWAYS OR DRIVEWAYS AND SHALL HAVE A MINIMUM DIMENSION OF 15'.

Level Placement on Building -----
 Alternate Placement on Building -----

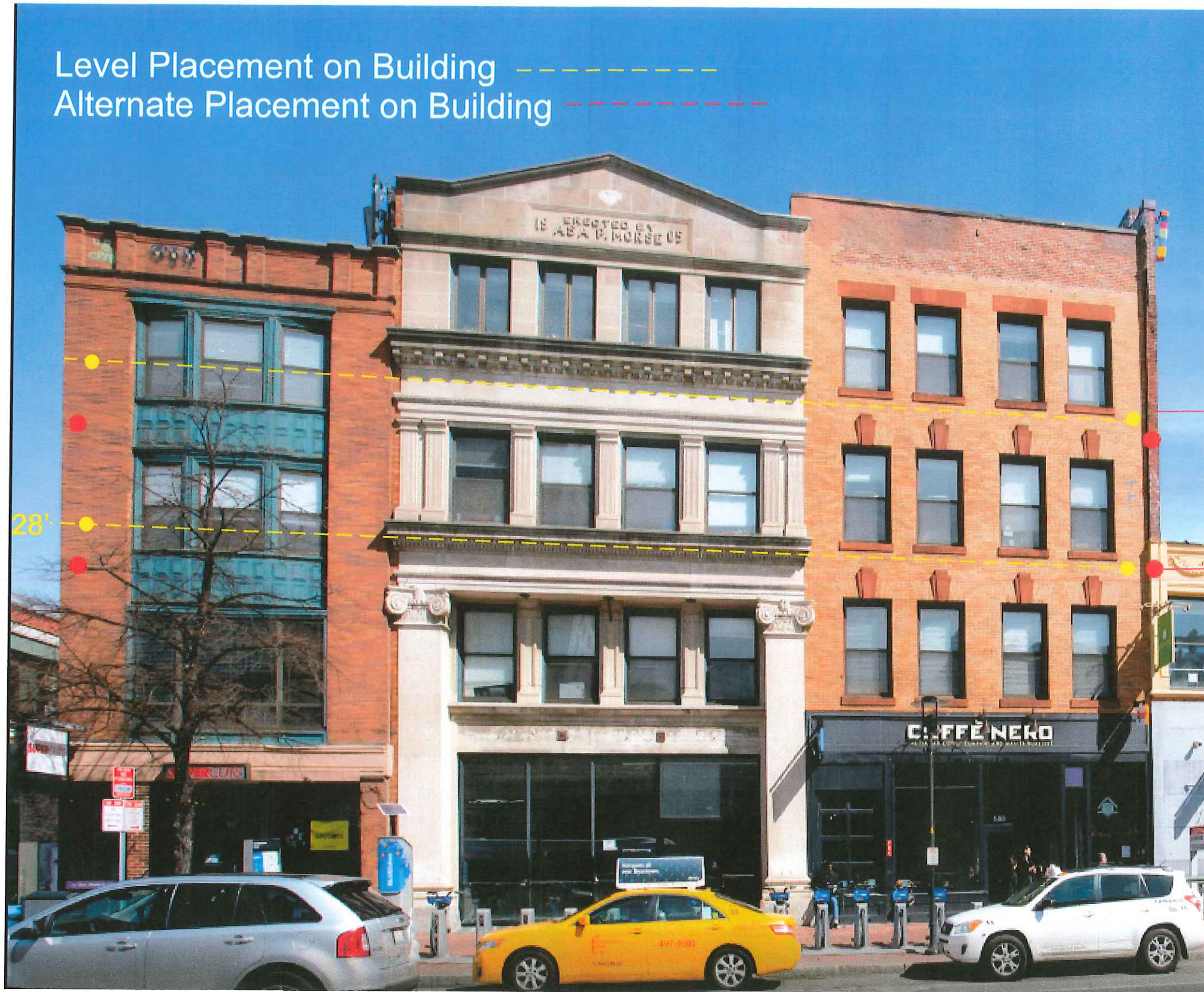

Top of Banner
above Grade

Base of Banner
above Grade

42'

28' Base of Banner
above Grade

Project Title:
Manifold Bio

Date: 3/20/23

Project Contact
 Sierra Goodrich

General Sign Specifications
 Interior Exterior
 Single Faced Double Faced
 Non-Illuminated Illuminated
 UL Labels # _____ of _____
 # of UL Sections _____ of _____
 Incoming 120 Volts 20 Amps(+/-)
 Location EXT. Windspeed _____

Drawing Revisions

Drawn By	Date	Change
▲ RMB	3/20/23	
▲		
▲		
▲		
▲		
▲		
▲		
▲		
▲		
▲		

- Approved, as is
- Approved, w/ changes
- Requires New Layout
- Rejected

Authorized Signature of Approval
 Title
 Date Signed

Electrical
 *SIGN MEETS NEC 600 ELECTRICAL REQUIREMENTS.
 20 amp weatherproof electrical disconnect required for every 16 amps of signage. Actual number of circuits to be determined by a licensed electrical contractor.
 Actual location of box may vary.
 Input voltage - 120V.
 All signage will be (UL) 485TD compliant.

Proposed View of Porperty



ARDON VISUAL
COMMUNICATIONS
167 BOW ST. UNIT 110 EVERETT, MA. 02149
1.888.578.6473
WWW.ARDONVISUAL.COM

Project Title:
Manifold Bio

Date: 3/20/23

Project Contact
Sierra Goodrich

General Sign Specifications
 Interior Exterior
 Single Faced Double Faced
 Non-Illuminated Illuminated
 UL Labels # _____ NA
 # of UL Sections _____ of _____
 Incoming 120 Volts 20 Amps(+/-)
 Location EXT. Windspeed _____

Drawing Revisions

Drawn By	Date	Change
▲ RMB	3/20/23	
▲		
▲		
▲		
▲		
▲		
▲		
▲		
▲		
▲		

- Approved, as is
- Approved, w/ changes
- Requires New Layout
- Rejected

Authorized Signature of Approval

 Title

 Date Signed

Electrical
 *SIGN MEETS NEC 600 ELECTRICAL REQUIREMENTS.
 20 amp weatherproof electrical disconnect required for every 16 amps of signage. Actual number of circuits to be determined by a licensed electrical contractor.
 Actual location of box may vary.
 Input voltage - 120V.
 All signage will be (U.L.) 48STD compliant.



Proposed View of Property



Existing View of Property



Project Title:
Manifold Bio

Date: 3/20/23

Project Contact
Sierra Goodrich

General Sign Specifications
 Interior Exterior
 Single Faced Double Faced
 Non-Illuminated Illuminated
 UL Labels # NA
 # of UL Sections _____ of _____
 Incoming 120 Volts 20 Amps(+/-)
 Location EXT. Windspeed 110+/-

Drawing Revisions		
Drawn By	Date	Change
△ RMB	3/20/23	
△		
△		
△		
△		
△		
△		
△		
△		

- Approved, as is
- Approved, w/ changes
- Requires New Layout
- Rejected

Authorized Signature of Approval

Title

Date Signed

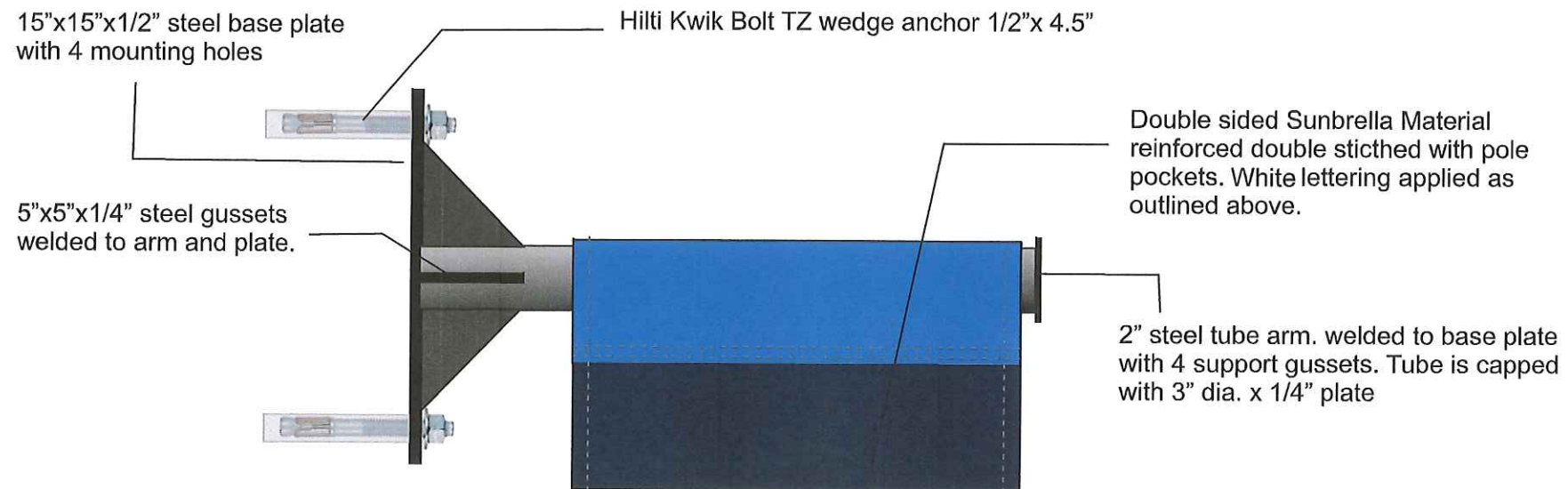

See plate details on pg.2



Electrical
 *SIGN MEETS NEC 600 ELECTRICAL REQUIREMENTS. 20 amp weatherproof electrical disconnect required for every 16 amps of signage. Actual number of circuits to be determined by a licensed electrical contractor. Actual location of box may vary. Input voltage - 120V. All signage will be (U.L.) 48STD compliant.

Project Title:
Manifold Bio

Date: 3/20/23

Project Contact
Sierra Goodrich

General Sign Specifications
 Interior Exterior
 Single Faced Double Faced
 Non-Illuminated Illuminated
 UL Labels # NA
 # of UL Sections _____ of _____
 Incoming 120 Volts 20 Amps(+/-)
 Location EXT. Windspeed _____

Drawing Revisions

Drawn By	Date	Change
▲ RMB	3/20/23	
▲		
▲		
▲		
▲		
▲		
▲		
▲		
▲		

- Approved, as is
- Approved, w/ changes
- Requires New Layout
- Rejected

Authorized Signature of Approval

Title

Date Signed

Electrical
 *SIGN MEETS NEC 600 ELECTRICAL REQUIREMENTS.
 20 amp weatherproof electrical disconnect required for every 16 amps of signage. Actual number of circuits to be determined by a licensed electrical contractor.
 Actual location of box may vary.
 Input voltage - 120V.
 All signage will be (U.L.) 48STD compliant.

Bottom Plate detail and tension bar

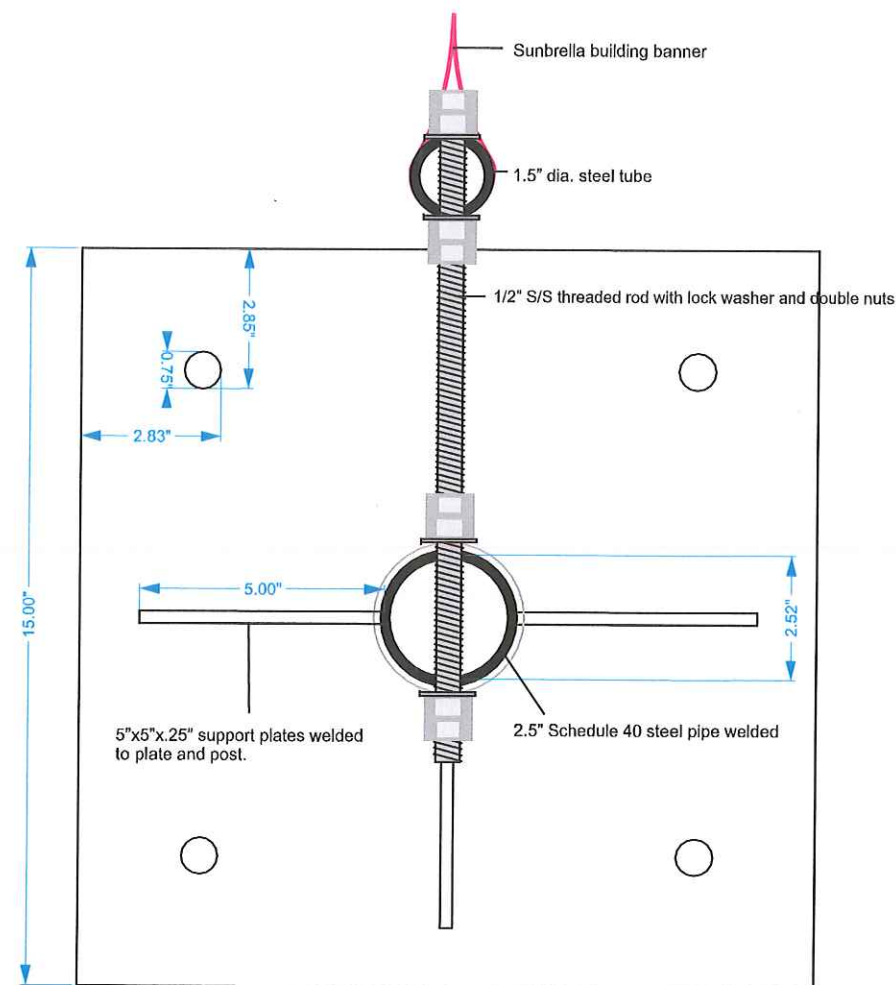

Top Plate detail and tension bar

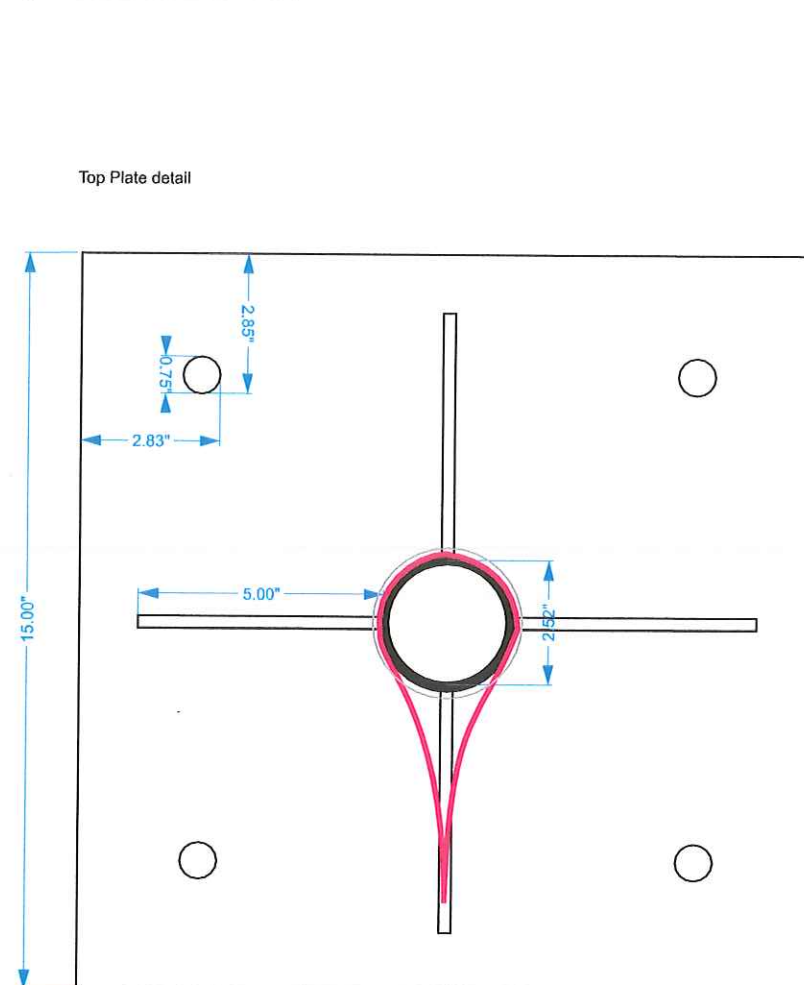

Banner area = 31.4sf



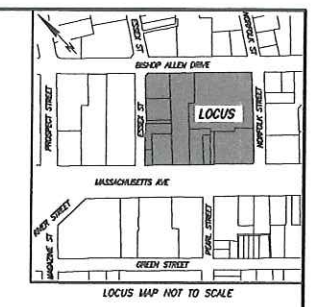
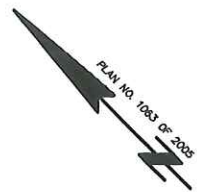

LEGEND:

- SEWER MANHOLE
- DRAIN MANHOLE
- ELECTRIC MANHOLE
- WATER MANHOLE
- TELEPHONE MANHOLE
- CABLE TV MANHOLE
- HYDRANT
- WATER SHUT OFF
- GAS SHUT OFF
- CATCH BASIN
- TRAFFIC CONTROL BOX
- TRAFFIC SIGNAL
- UTILITY POLE
- LIGHT POLE
- ELECTRIC HANDHOLE
- BOLLARD
- MAIL BOX
- PM PARKING METER
- IRRIGATION CONTROL VALVE
- CLEAN OUT
- COAL CHUTE
- FIRE ALARM
- STAND PIPE/WHAISLE CONNECTION
- ORNAMENTAL LIGHT
- GAS METER
- TRASH RECEPTACLE
- HANDICAP PARKING SPACE
- DECIDUOUS TREE
- HANDICAP RAMP
- BENCH
- BICYCLE RACK
- BICYCLE POST
- GATE POST
- TEMPORARY BENCH MARK
- RECORD
- CALCULATED
- ENT
- FINISH FLOOR ELEVATION
- BUILDING HEIGHT
- OVERHEAD DOOR
- VERTICAL GRANITE CURB
- CONCRETE CURB
- CHAIN LINK FENCE
- WROUGHT IRON FENCE
- LANDSCAPE TIMBER
- RETAINING
- GRANITE
- GRANITE
- BUTENOUS
- CONCRETE
- TOP OF STEPS
- BOTTOM OF STEPS
- TOP OF WALL
- BOTTOM OF WALL
- TOP OF CURB
- BOTTOM OF CURB
- RM ELEVATION
- INVERT ELEVATION
- TOP OF TROP
- CENTERLINE OF TROUGH
- BOTTOM ELEVATION
- UNACCESSIBLE
- NO VISIBLE PIPES
- TOP OF WATER
- TOP OF DEBRIS
- FULL OF DEBRIS
- FULL OF WATER
- SQUARE FEET
- MATCH & SHARPS
- LAND COURT CASE
- BACK
- COVER
- THRESHOLD
- GUARD RAIL
- FENCE
- SLOPER
- DOWN
- COMBINED SEWER
- WATER
- GAS
- ELECTRIC
- TELEPHONE
- CABLE TELEVISION
- OVERHEAD WIRES
- FIRE PROTECTION
- INTERIOR PARCEL UNREGISTERED LAND
- INTERIOR PARCEL REGISTERED LAND

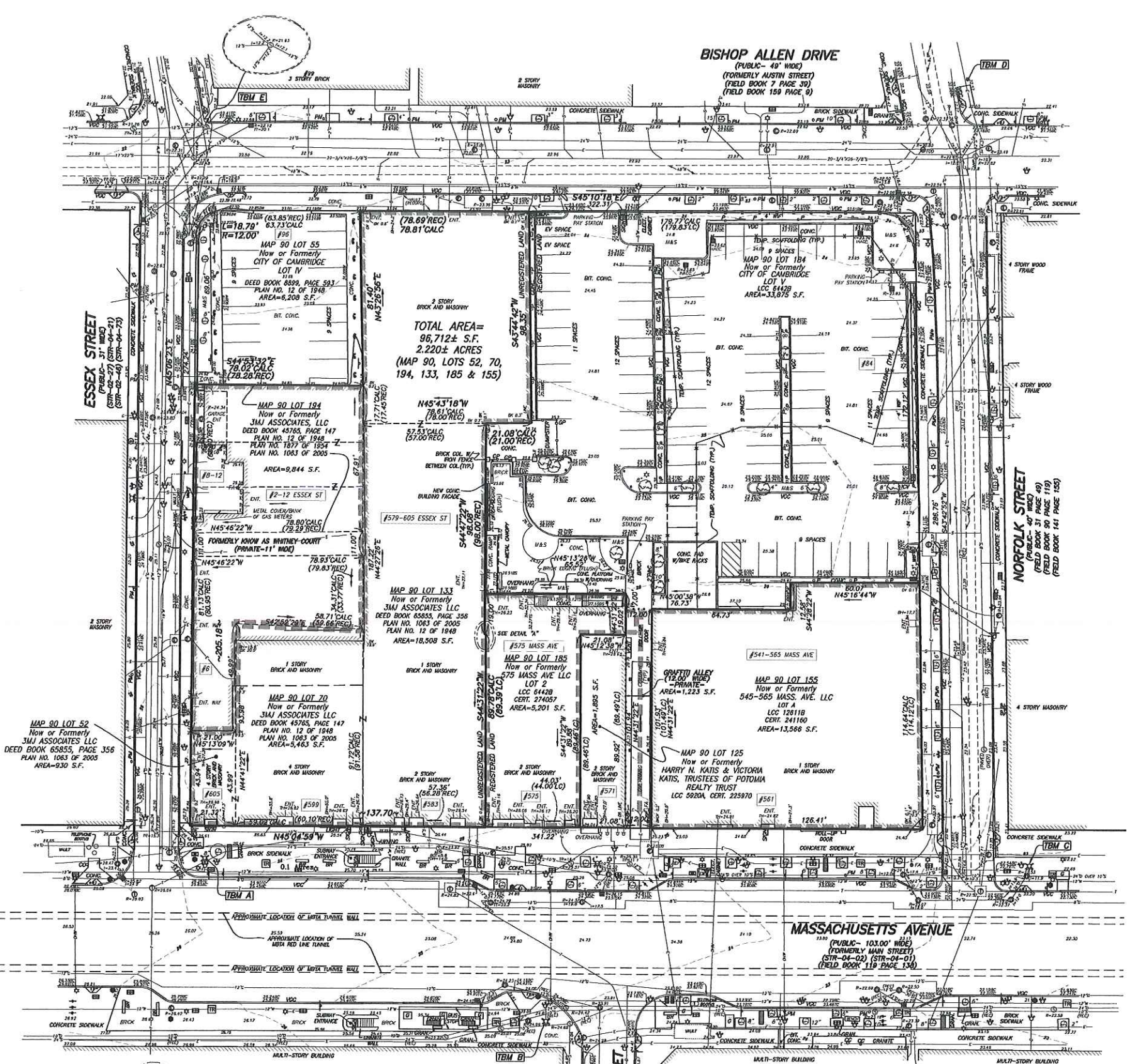

NOTES:

- 1) BENCHMARK INFORMATION:
BENCHMARK USED: CHASED SQUARE ON STONE BOUND WITH DRILL HOLE LOCATED AT THE SOUTHWEST CORNER OF THE INTERSECTION OF GREEN STREET AND WESTERN AVENUE. ELEVATION= 27.32
TAKEN FROM A PLAN ENTITLED "SITE PLAN, 349-357 GREEN STREET, CAMBRIDGE, MA," DATED NOVEMBER 1, 2001 PREPARED BY HODGE-EAST SURVEY. PLAN IS ON FILE WITH CITY OF CAMBRIDGE DEPARTMENT OF PUBLIC WORKS.
TEMPORARY BENCHMARKS SET:
TBM A - X CUT ON RIGHT FRONT BOLT OF HYDRANT LOCATED AT THE CORNER OF ESSEX STREET AND MASSACHUSETTS AVENUE, AS SHOWN ON PLAN. ELEVATION= 28.53
TBM B - X CUT ON RIGHT FRONT BOLT OF HYDRANT LOCATED AT THE CORNER OF PEARL STREET AND MASSACHUSETTS AVENUE, AS SHOWN ON PLAN. ELEVATION= 27.27
TBM C - X CUT ON RIGHT FRONT BOLT OF HYDRANT LOCATED AT THE CORNER OF NORFOLK STREET AND MASSACHUSETTS AVENUE, AS SHOWN ON PLAN. ELEVATION= 25.41
TBM D - RIGHT OUTER CORNER OF LOWEST STONE STEP LOCATED AT NO. 48 NORFOLK STREET, AS SHOWN ON PLAN. ELEVATION= 23.11
TBM E - RIGHT OUTER CORNER OF LOWEST STONE STEP LOCATED AT NO. 59 BISHOP ALLEN DRIVE, AS SHOWN ON PLAN. ELEVATION= 23.48
- 2) ELEVATIONS REFER TO CITY OF CAMBRIDGE DATUM.
- 3) CONTOUR INTERVAL EQUALS ONE (1) FOOT.
- 4) UTILITY INFORMATION SHOWN IS BASED ON BOTH A FIELD SURVEY AND PLANS OF RECORD. THE LOCATIONS OF UNDERGROUND PIPES AND CONDUITS HAVE BEEN DETERMINED FROM THE AFORESAID RECORD PLANS AND ARE APPROXIMATE ONLY. WE CANNOT ASSUME RESPONSIBILITY FOR DAMAGES INCURRED AS A RESULT OF UTILITIES THAT ARE OMITTED OR INACCURATELY SHOWN ON SAID RECORD PLANS. SINCE SUB-SURFACE UTILITIES CANNOT BE VISIBLY VERIFIED, BEFORE PLANNING FUTURE CONNECTIONS, THE PROPER UTILITY ENGINEERING DEPARTMENT SHOULD BE CONSULTED AND THE ACTUAL LOCATION OF SUB-SURFACE STRUCTURES SHOULD BE DETERMINED IN THE FIELD. CALL, TELL, FREE, THE DO SAFE CALL CENTER AT 1-888-344-7223 SEVENTY-TWO HOURS PRIOR TO EXCAVATION. THE CABLE TELEVISION PLANS PROVIDED ARE SCHEMATIC AND MAY NOT BE COMPLETE OR ACCURATE.
- 5) THIS DOCUMENT IS AN INSTRUMENT OF SERVICE OF HARRY R. FELDMAN, INC. ISSUED TO OUR CLIENT FOR PURPOSES RELATED DIRECTLY AND SOLELY TO HARRY R. FELDMAN, INC.'S SCOPE OF SERVICES UNDER CONTRACT TO OUR CLIENT FOR THIS PROJECT. ANY USE OR REUSE OF THIS DOCUMENT FOR ANY REASON BY ANY PARTY FOR PURPOSES UNRELATED DIRECTLY AND SOLELY TO SAID CONTRACT SHALL BE AT THE USER'S SOLE AND EXCLUSIVE RISK AND LIABILITY, INCLUDING LIABILITY FOR VIOLATION OF COPYRIGHT LAWS, UNLESS WRITTEN CONSENT IS PROVIDED BY HARRY R. FELDMAN, INC.
- 6) LOCATION OF UNDERGROUND METAL TUNNEL WALLS ARE SHOWN FROM VARIOUS UTILITY PLANS. THERE ARE LIKELY ADDITIONAL WALLS AND UTILITY LINES OWNED BY THE MTA WITHIN MASSACHUSETTS AVENUE TO SUPPORT AND SUPPLY INFRASTRUCTURE TO THE RED LINE. LOCATIONS SHOWN SHOULD BE CONSIDERED APPROXIMATE AND FIELD VERIFIED PRIOR TO CONSTRUCTION.
- 7) INVERTS OF SEWER AND DRAIN NOT OBTAINED ON THE EAST SIDE OF MASSACHUSETTS AVENUE FROM LOCUS.
- 8) TO DATE HARRY R. FELDMAN, INC. HAS NOT RECEIVED PLANS SHOWING UNDERGROUND TELEPHONE LINES FROM VERIZON.
- 9) BUILDING HEIGHTS SHOWN ARE FROM THE BACK OF SIDEWALK TO THE TOP OF PARAPET OR ROOF, WHICHEVER CAN BE SEEN FROM THE GROUND.

**EXISTING CONDITIONS PLAN OF LAND
NO. 541-605 MASSACHUSETTS AVENUE
NO. 84 NORFOLK STREET
NO. 96 BISHOP ALLEN DRIVE
CAMBRIDGE, MASS.**

FELDMAN LAND SURVEYORS NOVEMBER 24, 2020
152 HAMPDEN STREET PHONE: (617)357-9740
BOSTON, MASS. 02119 www.feldmansurveyors.com

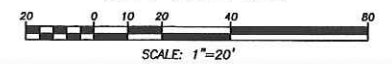

I CERTIFY THAT THIS PLAN IS BASED ON AN ACTUAL FIELD SURVEY AND THE LATEST PLANS AND DEEDS OF RECORD.

D. J. H. [Signature]
DAVID J. HANLEY, PLS (NOV 40629)
D.J.H@FELDMANLANDSURVEYORS.COM

DATE: 06-08-2021



RESEARCH	FIELD CHECK	PROJ. MGR.	APPROVED	SHEET NO.
DAVID	DAVID	DAVID	DAVID	1 OF 1
CALC	DAVID	DAVID	DAVID	JOB NO. 17147
FIELD CHECK	DAVID	DAVID	DAVID	

FILED: S:\PROJECTS\17100\17147\DWG\17147-01.dwg

AS-BUILT DOCUMENTATION

Essex & Massachusetts Ave Cambridge, MA 02139

DRAWING INDEX

- 0C1 COVER
- 0SL SYMBOLS LEGEND
- AB-0 BASEMENT
- AB-1 FIRST FLOOR
- AB-2 SECOND FLOOR
- AB-3 THIRD FLOOR
- AB-4 4TH, 5TH, & 6TH FLOORS
- AB-6 ROOF PLAN
- AB-7 3D EXTERIOR ELEVATIONS
- AB-8 3D SECTION
- AB-9 3D ROOF



**ARCHITECTURAL AS BUILT
Essex & Massachusetts Ave
Cambridge, MA 02139**

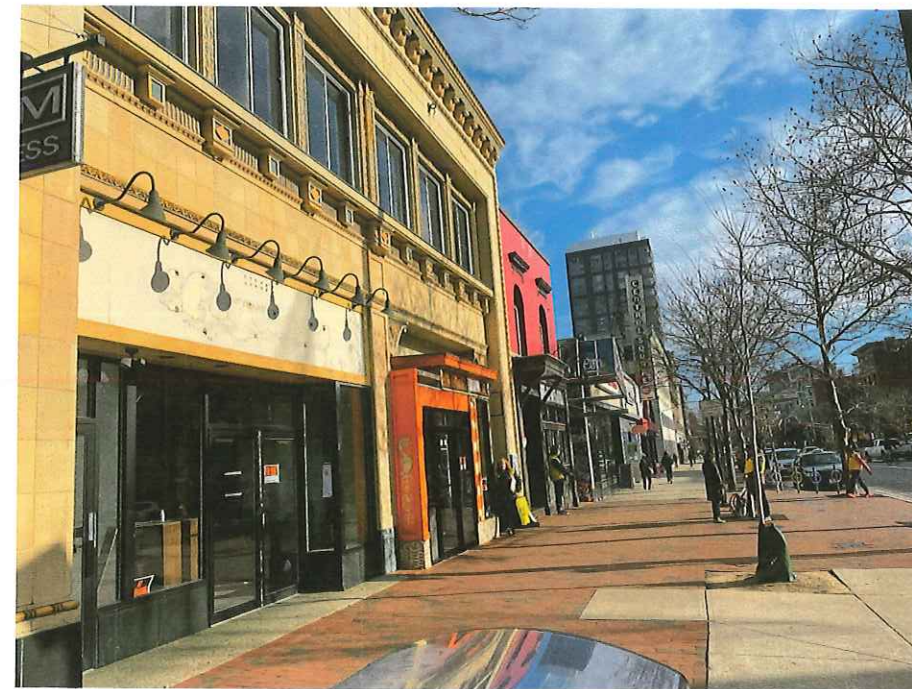
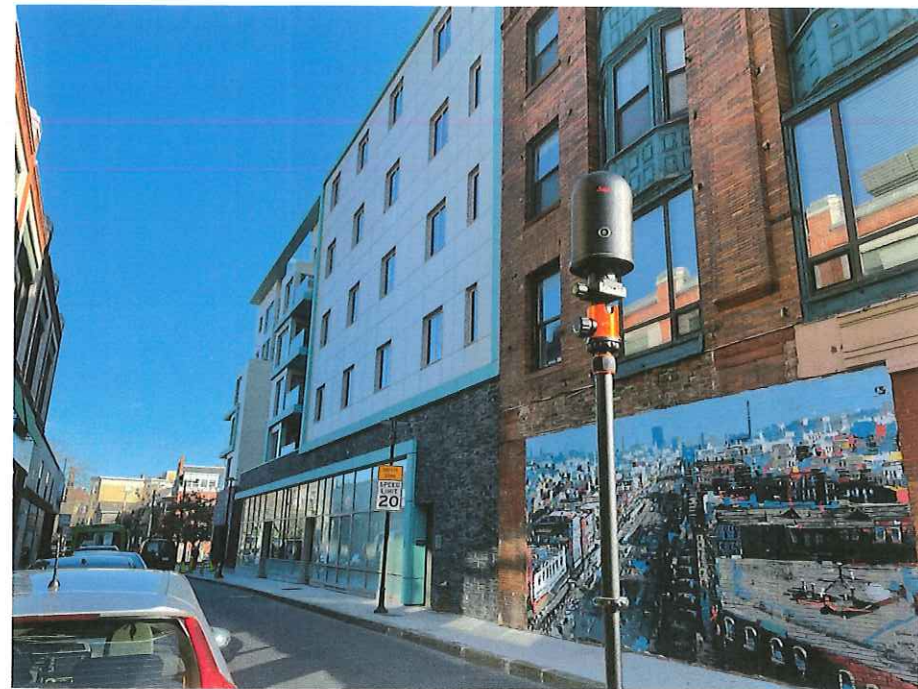

VICINITY MAP

AREA DATA	
Level	AREA
Not Placed	0 SF
Basement	41366 SF
Level 1	52317 SF
Level 2	24534 SF
Level 3	14233 SF
Level 4	14347 SF
Level 5	9304 SF
Level 6	7450 SF
Roof	52628 SF
Grand Total	224108 SF

100% SUBMITTAL

1/29/2021

COVER

0C1



SYMBOLS LEGEND

RCP

EXH	EXHAUST VENT	VL	TRACK LIGHT OR VANITY LIGHT
L1	CEILING MOUNTED LIGHT FIXTURE	NL	WALL-MOUNTED LIGHT FIXTURE
L	CEILING MOUNTED DIRECTIONAL LIGHT	ES	EMERGENCY EXIT SIGN
RC	RECESSED CAN LIGHT	EL	EMERGENCY EXIT LIGHT
EYE	EYEBALL OR SMALL CAN LIGHT	EEL	EMERGENCY EXIT LIGHT W/ SIGN
HPL	PENDANT LIGHT	STAIR	LIGHTED STAIR SIGN
FL	INDIVIDUAL FLUOR. LAY-IN FIXTURE 4 BULB	F	FLOOD LIGHT
FL2	INDIVIDUAL FLUOR. HANGING FIXTURE 2 BULB	PC	PHOTO CELL
FL3	INDIVIDUAL FLUOR. FLUSH MOUNT FIXTURE 4 BULB	F1	CEILING FAN
C	CAMERA	F1LK	CEILING FAN W/ LIGHT KIT
M	MOTION DET.	7-2-6	CEILING HEIGHT AND TRIM 7-2" ABOVE FLOOR BELOW WITH 6" CROWN MOULDING. NOTE: ALL CEILINGS NOT LABELED ARE PLASTER. CEILINGS SHOWN WITH A GRID ARE LAY IN ACOUSTICAL TILE..
SUP	SUPPLY VENT	J	JUNCTION BOX
SUP2	SUPPLY VENT		
RET	RETURN VENT		
RET2	RETURN VENT		
SPE	SPEAKER		

ELECTRIC

DAT	DATA OUTLET
TEL	TELEPHONE JACK
S1	ELECTRIC SWITCH
TV	CABLE TELEVISION OUTLET
P1	DUPLEX RECEPTACLE OUTLET
P3	SPECIAL PURPOSE CONNECTION OR OUTLET
PQ	QUADRIPLEX RECEPTACLE OUTLET
PF	FLOOR DUPLEX RECEPTACLE OUTLET
PNL	ELECTRIC PANEL
MTR	ELECTRIC METER
BUT	BUTTON SWITCH
DISC	DISCONNECT SWITCH
LG	GROUND/FLOOR LIGHT
KP	KEY PAD

FIRE PROTECTION

FE	FIRE EXTINGUISHER
FP	FIRE PULL
AS	FIRE ALARM (HORN/STROBE)
SD	SMOKE DETECTOR
SS	SMOKE ALARM SPEAKER
SP	SPRINKLER HEAD CEILING MOUNT
SPW	SPRINKLER HEAD WALL MOUNT

MEP

TH	THERMOSTAT
FD	FLOOR DRAIN
V	VALVE
HB	HOSE BIB
WS	WATER SUPPLY
HEAT	SUSPENDED GAS HEATER

MISC

BOLLARD	BOLLARD
ELEVATION SYMBOL	SPOT ELEVATION

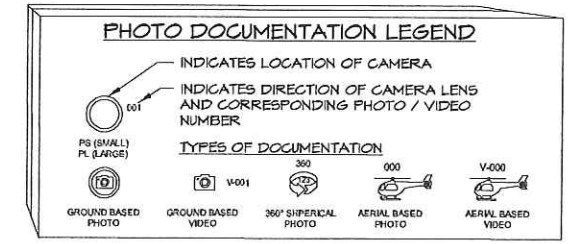
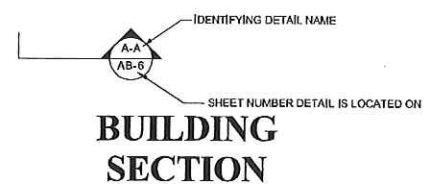
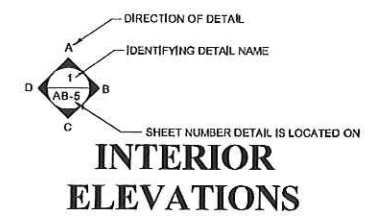

ARCHITECTURAL AS BUILT
Essex & Massachusetts Ave
Cambridge, MA 02139

SYMBOLS LEGEND

Designer	
Designer	
Project Number	
Date	
Author	
Scale	

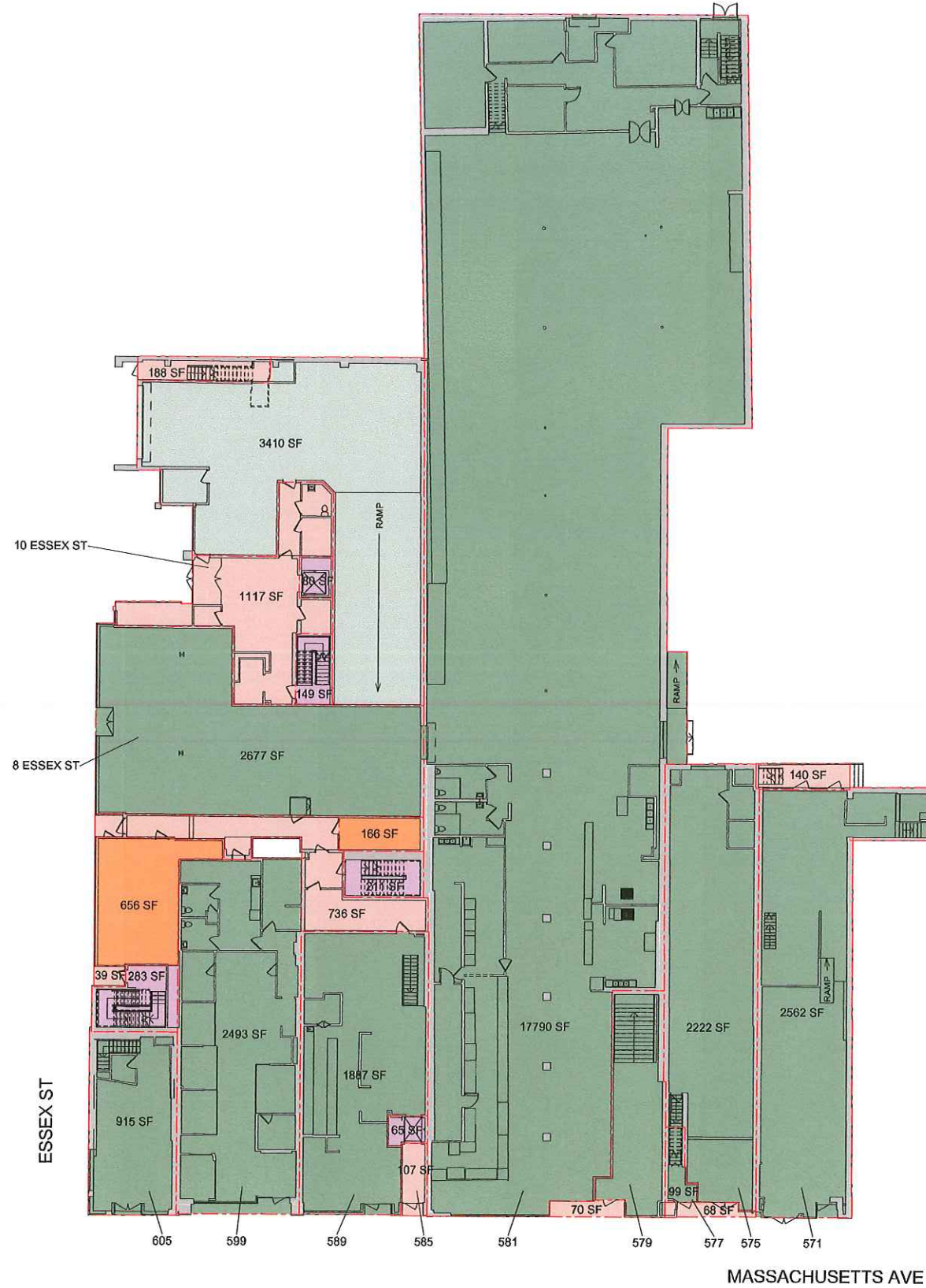

ALL AREA CALCULATIONS PER BOMA - Standard Methods of Measurement (ANSI/BOMA Z65.1-2017)

AREA DATA LEVEL 1

BUSINESS	44932 SF
COMMON AREA	2465 SF
MAJOR VERTICAL PENETRATION	781 SF
MECHANICAL	823 SF
PARKING	3410 SF
Grand Total	52311 SF

AREA LEGEND

- BUSINESS
- COMMON AREA
- MAJOR VERTICAL PENETRATION
- MECHANICAL
- PARKING

AS BUILT PROFESSIONALS
www.asbuiltprofessionals.com
A DIVISION OF:

AEC
CONSULTANTS INC

844.272.8458
844 ASBUILT

© 2020 AEC CONSULTANTS INC

ARCHITECTURAL AS BUILT
Essex & Massachusetts Ave
Cambridge, MA 02139

NO.	DESCRIPTION	DATE

FIRST FLOOR

Designer	PROJECT ARCHITECT
Project Number	3010
Author	DATE 1

AB-1

① Level 1
1/16" = 1'-0"



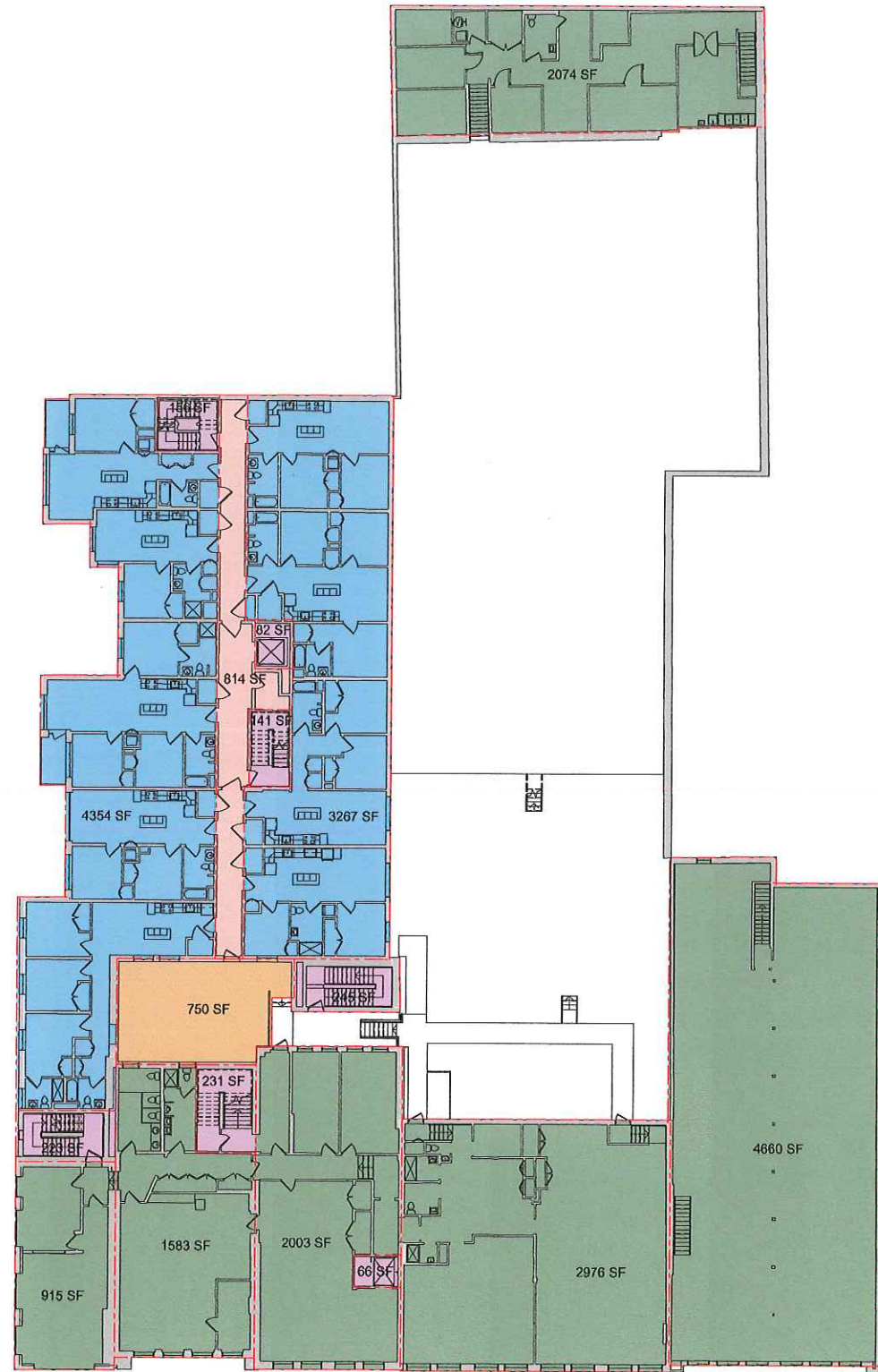

ALL AREA CALCULATIONS PER BOMA -
Standard Methods of Measurement
(ANSI/BOMA Z65.1-2017)

AREA DATA LEVEL 2	
BUSINESS	14210 SF
COMMON AREA	814 SF
MAJOR VERTICAL PENETRATION	1144 SF
RESIDENTIAL	7621 SF
SHARED AMENITY	750 SF
Grand total	24539 SF

AREA LEGEND

 BUSINESS
 COMMON AREA
 MAJOR VERTICAL PENETRATION
 RESIDENTIAL
 SHARED AMENITY

AS BUILT PROFESSIONALS
www.asbuiltprofessionals.com
A DIVISION OF:

AEC
CONSULTANTS INC
844.272.8458
844 ASBUILT

© 2020 AEC CONSULTANTS INC

ARCHITECTURAL AS BUILT
Essex & Massachusetts Ave
Cambridge, MA 02139

DATE	DESCRIPTION

SECOND FLOOR

Design by	
Designed by	
Project Number	

AB-2

① Level 2
1/16" = 1'-0"



AREA DATA LEVEL 4	
BUSINESS	4671 SF
COMMON AREA	784 SF
MAJOR VERTICAL PENETRATION	822 SF
RESIDENTIAL	8120 SF
Grand total	14347 SF

AREA DATA LEVEL 5	
COMMON AREA	145 SF
MAJOR VERTICAL PENETRATION	587 SF
RESIDENTIAL	1477 SF
Grand total	2209 SF

ALL AREA CALCULATIONS PER BOMA - Standard Methods of Measurement (ANSI/BOMA Z65.1-2017)

AREA DATA LEVEL 6	
COMMON AREA	748 SF
MAJOR VERTICAL PENETRATION	376 SF
RESIDENTIAL	6825 SF
Grand total	7949 SF

AREA LEGEND

 BUSINESS
 COMMON AREA
 MAJOR VERTICAL PENETRATION
 RESIDENTIAL

AS BUILT PROFESSIONALS
www.asbuiltprofessionals.com
A DIVISION OF:

AEC CONSULTANTS INC
844.272.8458
844 ASBUILT

© 2020 AEC CONSULTANTS INC

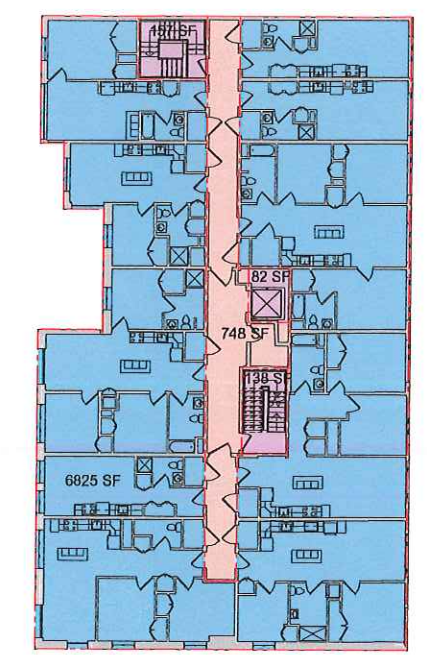
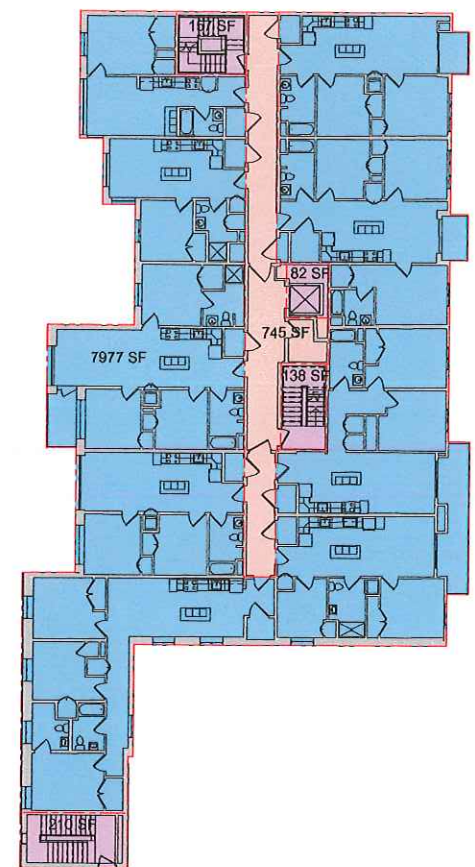
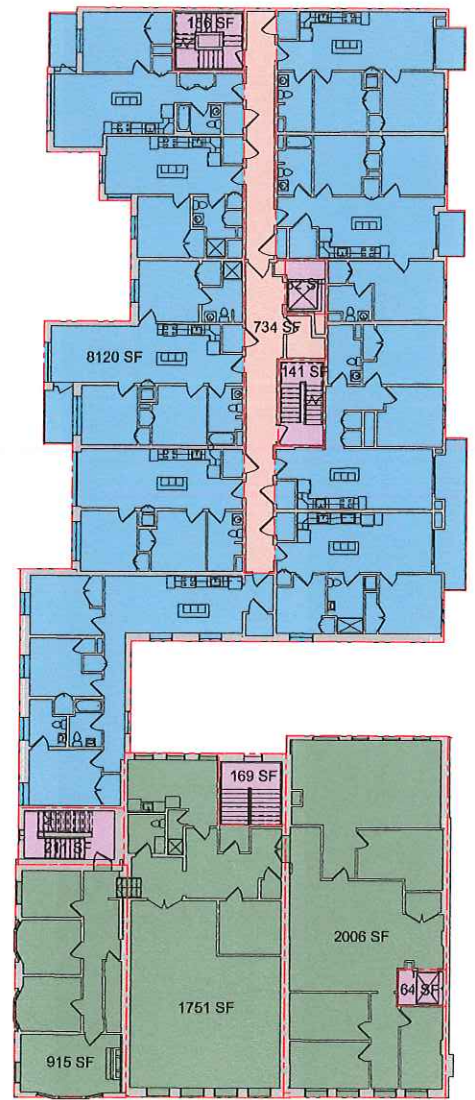

① Level 4
1/16" = 1'-0"

② Level 5
1/16" = 1'-0"

③ Level 6
1/16" = 1'-0"

ARCHITECTURAL AS BUILT
Essex & Massachusetts Ave
Cambridge, MA 02139

NO.	DATE	DESCRIPTION

4TH, 5TH, & 6TH FLOORS

Location	4TH, 5TH, 6TH FLOORS
Designer	AS BUILT PROFESSIONALS
Project Number	AB-4
Date	2020
Author	

AB-4

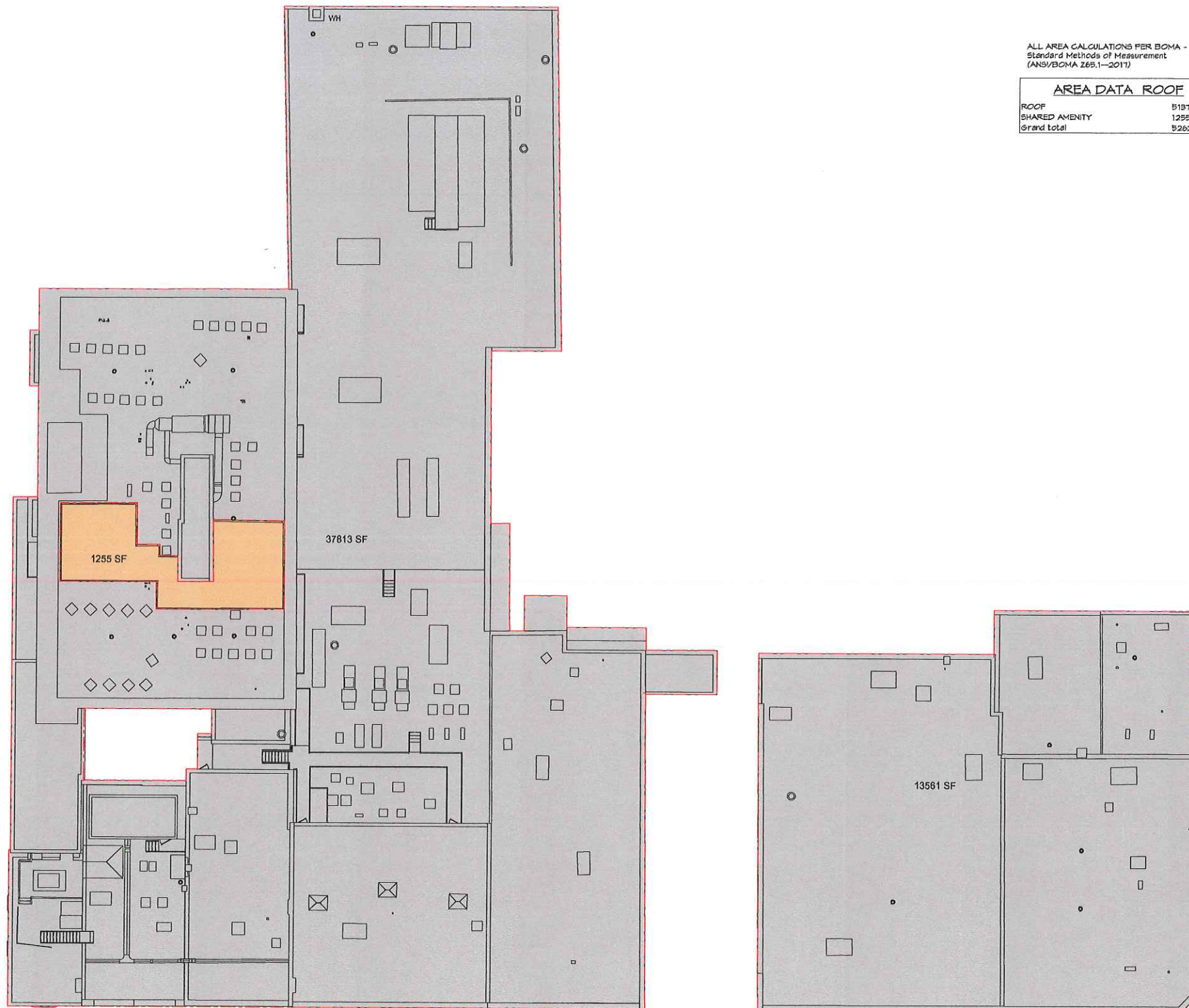

AREA LEGEND
 [Grey Box] ROOF
 [Orange Box] SHARED AMENITY

ALL AREA CALCULATIONS PER BOMA -
 Standard Methods of Measurement
 (ANSI/BOMA Z65.1-2011)

AREA DATA ROOF	
ROOF	51919 SF
SHARED AMENITY	1255 SF
Grand Total	52620 SF

AS BUILT
PROFESSIONALS
 www.asbuiltprofessionals.com
 A DIVISION OF:

AEC
 CONSULTANTS INC
 844.272.8458
 844 AS BUILT

© 2020 AEC CONSULTANTS INC

ARCHITECTURAL AS BUILT
Essex & Massachusetts Ave
Cambridge, MA 02139

NO.	DATE	DESCRIPTION

ROOF PLAN

Design by	AEC CONSULTANTS INC
Designed by	PROJECT ARCHITECT
Project Number	2019-001
Date	2020
Author	MARK
Scale	1/16" = 1'-0"

AB-6

② Roof
 1/16" = 1'-0"



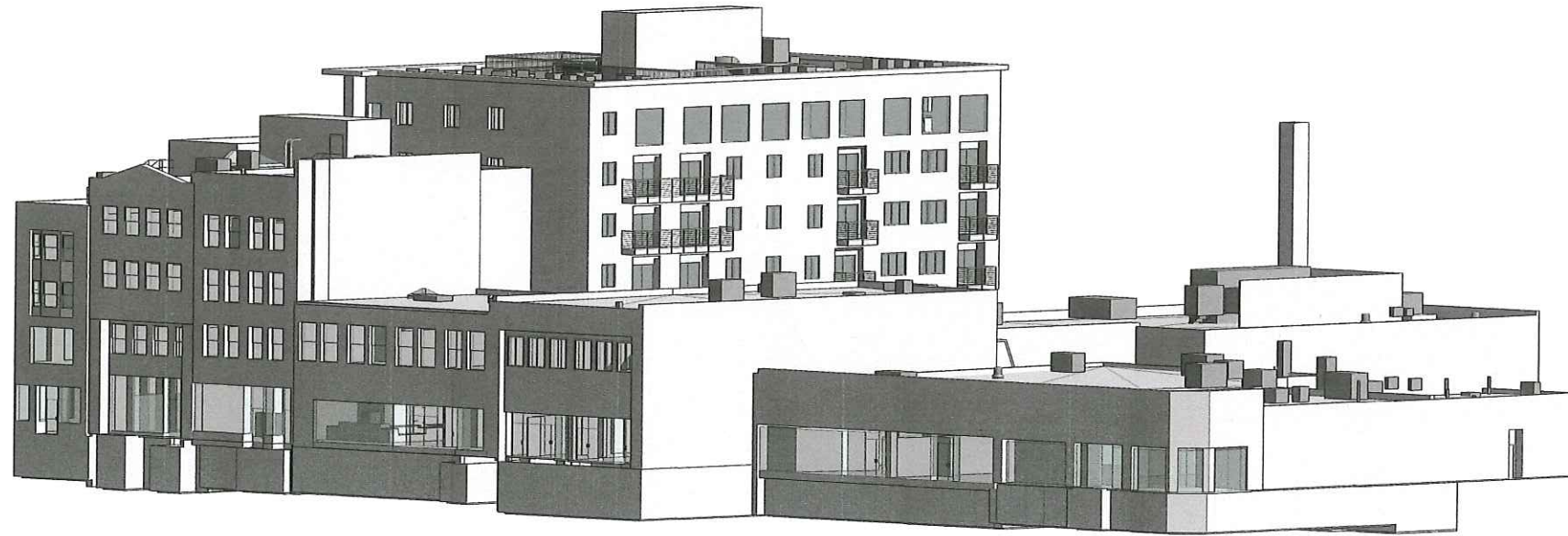
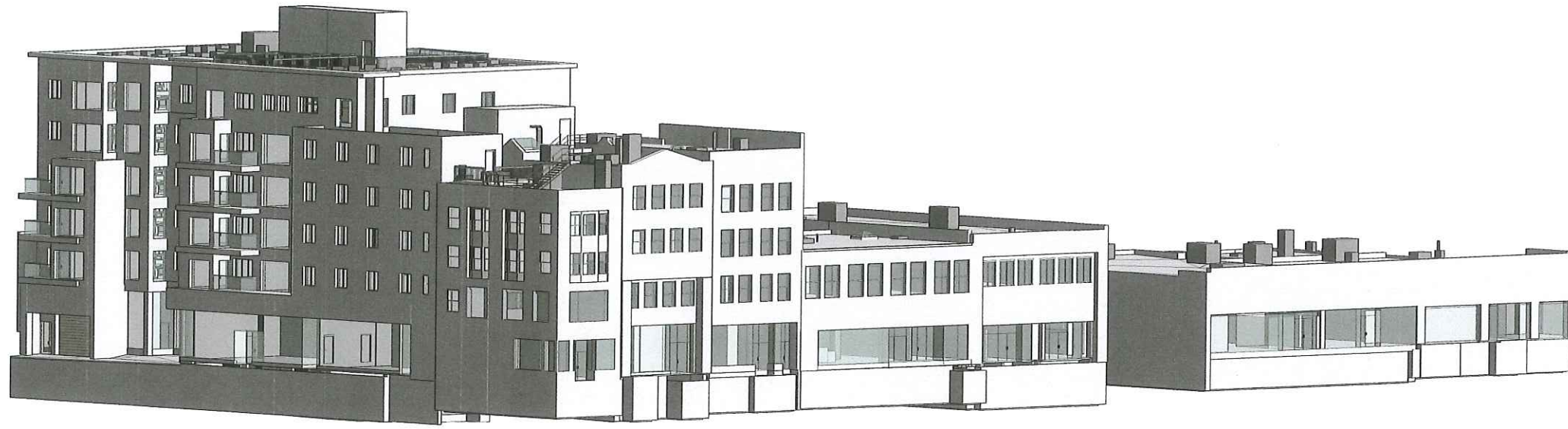

AS BUILT
PROFESSIONALS
www.asbuiltprofessionals.com
 A DIVISION OF:



© 2020 AEC CONSULTANTS INC

ARCHITECTURAL AS BUILT
Essex & Massachusetts Ave
Cambridge, MA 02139

3D EXTERIOR ELEVATIONS

Designer	AS BUILT
Project Number	PROJECT NUMBER
Date	DATE
Author	NAME

AB-7

Google Maps

585 Massachusetts Ave Cambridge MA



Image capture: Nov 2020 © 2023 Google



PLAN NO. 1063 OF 2005

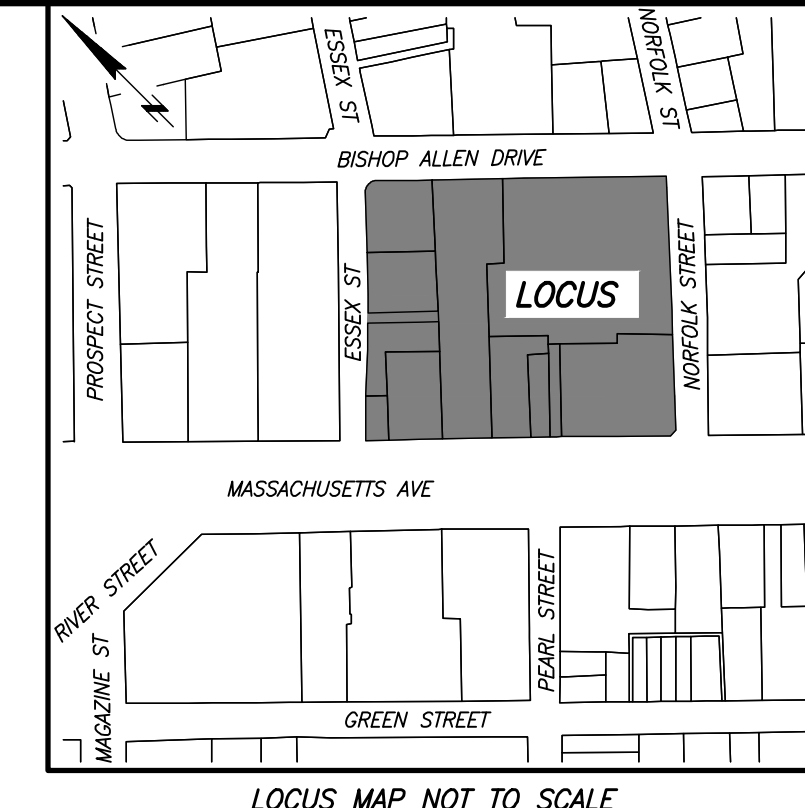

- LEGEND:**
- SEWER MANHOLE
 - DRAIN MANHOLE
 - ELECTRIC MANHOLE
 - WATER MANHOLE
 - TELEPHONE MANHOLE
 - CABLE TV MANHOLE
 - MANHOLE
 - HYDRANT
 - WATER SHUT OFF
 - GAS SHUT OFF
 - CATCH BASIN
 - TRAFFIC CONTROL BOX
 - TRAFFIC SIGNAL
 - UTILITY POLE
 - LIGHT POLE
 - ELECTRIC HANDHOLE
 - BOLLARD
 - MAIL BOX
 - SIGN
 - PARKING METER
 - IRRIGATION CONTROL VALVE
 - CLEAN OUT
 - COAL CHUTE
 - FIRE ALARM
 - STAND PIPE/SAMOSE CONNECTION
 - ORNAMENTAL LIGHT
 - GAS METER
 - TRASH RECEPTACLE
 - HANDICAP PARKING SPACE
 - DECIDUOUS TREE
 - HANDICAP RAMP
 - BENCH
 - BICYCLE RACK
 - BICYCLE POST
 - GATE POST
 - TEMPORARY BENCH MARK
 - RECORD
 - CALC
 - ENT
 - FINISH FLOOR ELEVATION
 - BHD
 - OVERHEAD DOOR
 - VGC
 - CONCRETE CURB
 - CHAIN LINK FENCE
 - WIF
 - LANDSCAPE TIMBER
 - RET
 - GRAN
 - BIT
 - CONC
 - TS
 - BTM
 - TW
 - BW
 - TC
 - BC
 - Rm
 - IT
 - TR
 - BTM
 - INACC
 - NVP
 - TOW
 - TOD
 - FOD
 - FOW
 - S.F.
 - MAS
 - LOC
 - BK
 - OV
 - TH
 - GUARD RAIL
 - FENCE
 - SEWER
 - DRAIN
 - CS
 - W
 - G
 - E
 - T
 - C
 - OHW
 - FP
 - INTERIOR PARCEL UNREGISTERED LAND
 - INTERIOR PARCEL REGISTERED LAND

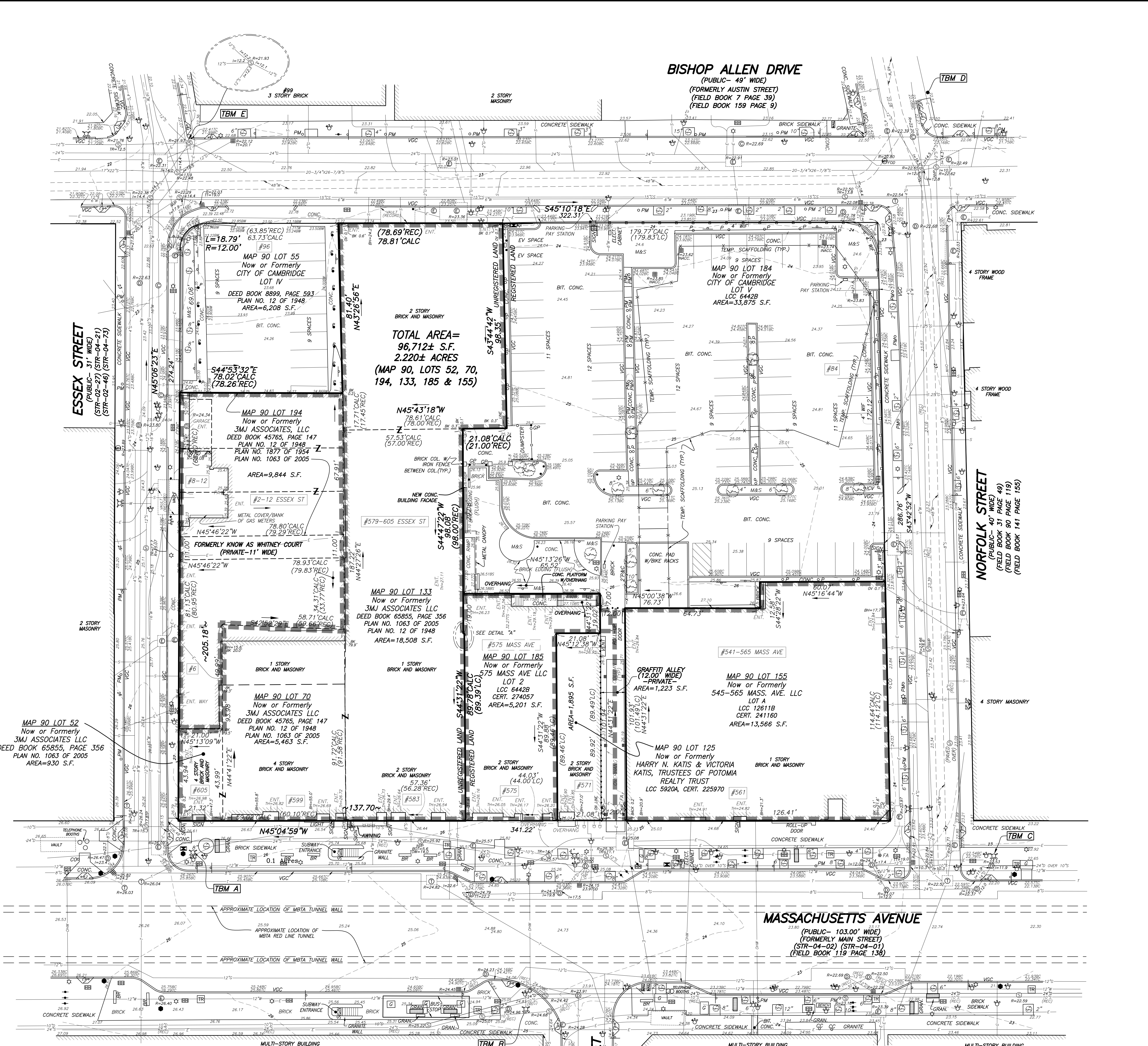

- NOTES:**
- BENCHMARK INFORMATION:
 - BENCHMARK USED: CHISELED SQUARE ON STONE BOUND WITH DRILL HOLE LOCATED AT THE SOUTHWEST CORNER OF THE INTERSECTION OF GREEN STREET AND WESTERN AVENUE. ELEVATION= 27.32
 - TAKEN FROM A PLAN ENTITLED "SITE PLAN, 349-357 GREEN STREET, CAMBRIDGE, MA," DATED NOVEMBER 1, 2001 PREPARED BY NORDE-EAST SURVEY, PLAN IS ON FILE WITH CITY OF CAMBRIDGE DEPARTMENT OF PUBLIC WORKS.
 - TEMPORARY BENCHMARKS SET:
 - TBM A - X CUT ON RIGHT FRONT BOLT OF HYDRANT LOCATED AT THE CORNER OF ESSEX STREET AND MASSACHUSETTS AVENUE, AS SHOWN ON PLAN. ELEVATION= 28.53
 - TBM B - X CUT ON RIGHT FRONT BOLT OF HYDRANT LOCATED AT THE CORNER OF PEARL STREET AND MASSACHUSETTS AVENUE, AS SHOWN ON PLAN. ELEVATION= 27.27
 - TBM C - X CUT ON RIGHT FRONT BOLT OF HYDRANT LOCATED AT THE CORNER OF NORFOLK STREET AND MASSACHUSETTS AVENUE, AS SHOWN ON PLAN. ELEVATION= 25.41
 - TBM D - RIGHT OUTER CORNER OF LOWEST STONE STEP LOCATED AT NO. 48 NORFOLK STREET, AS SHOWN ON PLAN. ELEVATION= 23.11
 - TBM E - RIGHT OUTER CORNER OF LOWEST STONE STEP LOCATED AT NO. 89 BISHOP ALLEN DRIVE, AS SHOWN ON PLAN. ELEVATION= 23.48
 - ELEVATIONS REFER TO CITY OF CAMBRIDGE DATUM.
 - CONTOUR INTERVAL EQUALS ONE (1) FOOT.
 - UTILITY INFORMATION SHOWN IS BASED ON BOTH A FIELD SURVEY AND PLANS OF RECORD. THE LOCATIONS OF UNDERGROUND PIPES AND CONDUITS HAVE BEEN DETERMINED FROM THE AFORESAID RECORD PLANS AND ARE APPROXIMATE ONLY. WE CANNOT ASSUME RESPONSIBILITY FOR DAMAGES INCURRED AS A RESULT OF UTILITIES THAT ARE OMITTED OR INACCURATELY SHOWN ON SAID RECORD PLANS, SINCE SUB-SURFACE UTILITIES CANNOT BE VISIBLY VERIFIED. BEFORE PLANNING FUTURE CONNECTIONS, THE PROPER UTILITY ENGINEERING DEPARTMENT SHOULD BE CONSULTED AND THE ACTUAL LOCATION OF SUB-SURFACE STRUCTURES SHOULD BE DETERMINED IN THE FIELD. CALL, TOLL FREE, THE DIG SAFE CALL CENTER AT 1-888-344-7233 SEVENTY-TWO HOURS PRIOR TO EXCAVATION. THE CABLE TELEVISION PLANS PROVIDED ARE SCHEMATIC AND MAY NOT BE COMPLETE OR ACCURATE.
 - THIS DOCUMENT IS AN INSTRUMENT OF SERVICE OF HARRY R. FELDMAN, INC. ISSUED TO OUR CLIENT FOR PURPOSES RELATED DIRECTLY AND SOLELY TO HARRY R. FELDMAN, INC.'S SCOPE OF SERVICES UNDER CONTRACT TO OUR CLIENT FOR THIS PROJECT. ANY USE OR REUSE OF THIS DOCUMENT FOR ANY REASON BY ANY PARTY FOR PURPOSES UNRELATED DIRECTLY AND SOLELY TO SAID CONTRACT SHALL BE AT THE USER'S SOLE AND EXCLUSIVE RISK AND LIABILITY, INCLUDING LIABILITY FOR VIOLATION OF COPYRIGHT LAWS, UNLESS WRITTEN CONSENT IS PROVIDED BY HARRY R. FELDMAN, INC.
 - LOCATION OF UNDERGROUND METAL TUNNEL WALLS ARE SHOWN FROM VARIOUS UTILITY PLANS. THERE ARE LIKELY ADDITIONAL WALLS AND UTILITY LINES OWNED BY THE MBTA WITHIN MASSACHUSETTS AVENUE TO SUPPORT AND SUPPLY INFRASTRUCTURE TO THE RED LINE. LOCATIONS SHOWN SHOULD BE CONSIDERED APPROXIMATE AND FIELD VERIFIED PRIOR TO CONSTRUCTION.
 - INVERTS OF SEWER AND DRAIN NOT OBTAINED ON THE FAR SIDE OF MASSACHUSETTS AVENUE FROM LOCUS.
 - TO DATE HARRY HARRY R. FELDMAN, INC. HAS NOT RECEIVED PLANS SHOWING UNDERGROUND TELEPHONE LINES FROM VERIZON.
 - BUILDING HEIGHTS SHOWN ARE FROM THE BACK OF SIDEWALK TO THE TOP OF PARAPET OR ROOF, WHICHEVER CAN BE SEEN FROM THE GROUND.

I CERTIFY THAT THIS PLAN IS BASED ON AN ACTUAL FIELD SURVEY AND THE LATEST PLANS AND DEEDS OF RECORD.

DAMIEN J. RAFFLE, PLS (MA# 49629)
DJR@FELDMANSURVEYORS.COM

06-08-2021
DATE

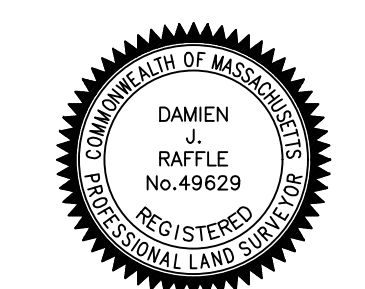

EXISTING CONDITIONS PLAN OF LAND NO. 541-605 MASSACHUSETTS AVENUE NO. 84 NORFOLK STREET NO. 96 BISHOP ALLEN DRIVE CAMBRIDGE, MASS.

FELDMAN LAND SURVEYORS
152 HAMPDEN STREET
BOSTON, MASS. 02119

NOVEMBER 24, 2020
PHONE: (617)357-9740
www.feldmansurveyors.com

FELDMAN
LAND SURVEYORS

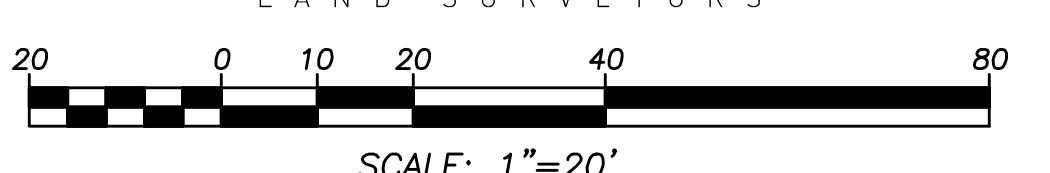

RESEARCH	FELD CHIEF NC	PROJ MGR DJR	APPROVED	SHEET NO. 1 OF 1
CALC	CADD BU/WJK	FIELD CHECKED NC	CRD FILE 17747	JOB NO. 17747
FILENAME: S:\PROJECTS\17700\17747\DWG\17747-EC.dwg				



Image capture: Nov 2020 © 2023 Google

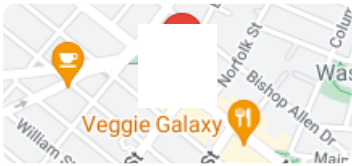

PROPERTY OWNER'S LETTER OF AUTHORIZATION

April 27, 2023

City of Cambridge
795 Massachusetts Avenue
Cambridge, MA 02139

RE: Dimagi

To Whom It May Concern:

I Morris M. Naggar of 585 Massachusetts Avenue, Cambridge, MA 02139 owner of said property, hereby authorize the above-referenced tenant to obtain new/and or change existing signage at the above-referenced address.

I also authorize Ardon Visual Communications and its employees of Woburn, MA 01801 to obtain the required and necessary permits, licenses, and approvals, which may be required for the installation of said signage and proceed with the installation if in accordance with all the governing laws, statues, and ordinances.

Signature: M. M. Naggar

Printed: Morris M. Naggar

Telephone: (617) 549-0070

E-mail: Morris@3MJrealty.com



Lena Kalachian
NOTARY PUBLIC
Commonwealth of Massachusetts
My Commission Expires
June 1, 2029



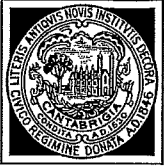

CITY OF CAMBRIDGE
Community Development Department

SIGN CERTIFICATION FORM
COVER SHEET

IRAM FAROOQ
Assistant City Manager for
Community Development

SANDRA CLARKE
Deputy Director
Chief of Administration

KHALIL MOGASSABI
Deputy Director
Chief of Planning

Sign Text: Dimagi

Location of Sign: 585 Massachusetts Ave

Applicant: Janice Ernst

Ardon Visual Communications, 167 Bow Street, Ste. 110, Everett MA 02149

Zoning District: _____ Overlay District: _____

Area of Special Planning Concern: (Sec. 19.46 & 19.42.1) _____

Application Date: 07/21/2023

Sketch of sign enclosed: Yes No

PLEASE NOTE: All signs must receive a permit from the Inspectional Services Department (ISD) before installation. Community Development Department Certification action does NOT constitute issuance of a permit or certification that all other code requirements have been met. Do not contract for the fabrication of a sign until all permits have been issued including City Council approval, if necessary for signs in the public way*.

* Any sign or portion of a sign extending more than six (6) inches into the public way/sidewalk, must receive approval from the Cambridge City Council; a bond must be posted with the City Clerk.

The Sign Ordinance is available online under Article 7.000 at <https://www.cambridgema.gov/CDD/zoninganddevelopment/Zoning/Ordinance>

Contact Liza Paden at 617 349 4647 or lpaden@cambridgema.gov for further information.

Proposed WALL Sign

Area in Square feet: _____ Dimensions: _____ X _____

Illumination: Natural _____ Internal _____ External _____

Height (from ground to the top of the sign): _____

1. COMPLETE WHEN SIGN IS ACCESSORY TO A FIRST FLOOR STORE

Length in feet of store front facing street: (a) _____. Area of signs allowed accessory to store: outside (1 x a) _____, behind windows (0.5 x a) _____. Area of all existing signs on the store front to remain (including any freestanding sign): _____. Area of additional signs permitted: _____.

2. COMPLETE FOR ANY OTHER SIGN

Length in feet of building facade facing street: (a) _____. Area of signs allowed accessory to the building facade: outside (1 x a) _____, behind windows (0.5 x a) _____. Area of all existing signs on the building facade to remain (including any freestanding sign): _____. Area of additional signs permitted: _____.

SUMMARY OF LIMITATIONS FOR WALL SIGNS (see reverse side for more general summary of the sign regulations; review Article 7.000 of the Zoning Ordinance for all zoning requirements.)

AREA: 60 square feet maximum. HEIGHT ABOVE THE GROUND: 20 feet but below the sills of second floor windows. ILLUMINATION: Natural or external, or internal illumination with significant limitations. NUMBER: No limit.

COMMUNITY DEVELOPMENT DEPARTMENT CERTIFICATION

Sign conforms to requirements of Article 7.000: YES _____ NO _____

Sign requires a variance from the Board of Zoning Appeal: YES _____

Relevant sections: _____

COMMENTS: _____

Date: _____ CDD Representative _____

Proposed FREESTANDING Sign

Area in Square feet: _____ Dimensions: _____ X _____

Illumination: Natural ___ Internal ___ External ___

Height (from ground to the top of the sign): _____

1. COMPLETE WHEN SIGN IS ACCESSORY TO A FIRST FLOOR STORE

Length in feet of store front facing street: (a) _____. Area of signs allowed accessory to store: outside (1 x a) _____, behind windows (0.5 x a) _____. Area of all existing signs on the store front to remain (including any freestanding sign): _____. Area of additional signs permitted: _____.

2. COMPLETE FOR ANY OTHER SIGN

Length in feet of building facade facing street: (a) _____ Area of signs allowed accessory to the building facade: outside (1 x a) _____, behind windows (0.5 x a) _____ Area of all existing signs on the building facade to remain (including any freestanding sign): _____ Area of additional signs permitted: _____.

SUMMARY OF LIMITATIONS FOR FREESTANDING SIGNS (see reverse side for more general summary of the sign regulations; review Article 7.000 of the Zoning Ordinance for all zoning requirements.)
AREA: 30 square feet maximum. HEIGHT ABOVE THE GROUND: 15 feet. ILLUMINATION: Natural or external only. NUMBER: Two per lot (but not exceeding 30 square feet in total area).

COMMUNITY DEVELOPMENT DEPARTMENT CERTIFICATION

Sign conforms to requirements of Article 7.000: YES _____ NO _____

Sign requires a variance from the Board of Zoning Appeal: YES _____

Relevant sections: _____

COMMENTS: _____

Date: _____ CDD Representative _____

Existing Legally Established NONCONFORMING Sign

Area in Square feet: _____ Dimensions: _____ X _____

Illumination: Natural Internal _____ External _____

Height (from ground to the top of the sign): 83

1. TYPE OF SIGN

a. wall _____ b. projecting _____ c. freestanding _____

2. REASON FOR NONCONFORMITY

a. dimensions b. illumination _____ c. other _____

3. NATURE OF ALTERATIONS

a. replacement of plastic face _____ b. repainting of face _____ c. other

I certify that the above referenced sign was legally erected and in conformance with the requirements of Article 7.000 at that time and further that the alterations now proposed, and any others made within the last three (3) years, do not exceed fifty (50%) percent of the current replacement value of the sign.)

Date: _____ Applicant signature: _____

COMMUNITY DEVELOPMENT DEPARTMENT CERTIFICATION

Sign conforms to requirements of Article 7.000: YES _____ NO _____

Sign requires a variance from the Board of Zoning Appeal: YES

Relevant sections: _____

COMMENTS: _____

Date: _____ CDD Representative _____

**SIGN CERTIFICATION FORM
COMMUNITY DEVELOPMENT DEPARTMENT**

CERTIFICATION OF EXEMPTION

Applicant: Janice Ernst

Ardon Visual Communications

167 Bow Street, Suite 110 Everett, MA 02149

Signature _____

Telephone: 857-256-4370 **FAX:** _____

Location of Premises: 585 Massachusetts Ave. Cambridge MA

Zoning District: _____ **Overlay District:** _____

Date Application Submitted: 07/21/2023

Sketch of Sign Enclosed: Yes No

PLEASE NOTE: Signs, even if exempt under Article 7.000, may require a permit from the Inspectional Services Department (ISD) before installation. Community Development Department (CDD) action does NOT constitute issuance of a permit or certification that all other code requirements have been met. Awnings of any kind projecting over a city sidewalk require City Council approval.

REASON FOR EXEMPTION: *Awning without graphics* _____ *Exempt signs in Section 7.16.11 (including directional signs)* _____

Date: _____ **CDD Representative** _____

Copies: ISD _____ City Clerk* _____ CDD _____ Applicant _____

Summary of Major Provisions for Office, Business and Industrial Districts

(Please consult Article 7.000 of the Zoning Ordinance for specific requirements)

Limitations on Total Area of the Signs on a Building

(See definition of sign frontage)

1. **For Ground Floor stores:** Width of store x 1 square foot equals area of all signs permitted on the outside of the storefront
2. **For all signs on a single façade of a building:** (including those in paragraph 1 above): Width of building façade facing a street x 1 square foot equals area of all signs permitted on that façade. * *

(Note: An additional 0.5 square feet per foot of sign frontage is permitted for signs located behind the glass of a window).

Limitations on the Height of Signs Above the Ground

Fifteen (15) for free-standing signs; twenty (20) feet for all other signs with exception for certain hotel and theater signs.

Limitations on Area of Individual Signs

1. Wall signs: Sixty (60) Square feet Maximum. *
2. Projecting Signs: Thirteen (13) square feet maximum. *
3. Free-standing signs: Thirty (30) Square feet maximum. *

* However no sign may exceed that area determined by the formula: sign frontage x 1 square foot.

Limitations on Number of Signs Permitted

1. No limit
2. Projecting signs: one per ground floor establishment plus one per door serving the remainder of the building.
3. Free-standing Signs: Two per lot.

Limitations on Kinds of Illumination

1. Projecting (including awning signs) and free-standing signs: Natural and external only.
2. Wall signs: Natural or external without limit. Internal under the following conditions:
 - a. At least one dimension is 30" or less; and
 - b. The sign is located behind window glass or projects no more than 2" from the building face; or the sign consists only of individual letters, or channel letters, or only the letters in a box sign illuminated.

** Where the sign frontage is more than 100 feet from a street the multiplier may be increased to 2 square feet.



City of Cambridge Community Development Department STOREFRONT IMPROVEMENT PROGRAM

The City of Cambridge Community Development Department (CDD) established the Storefront Improvement Program to provide financial assistance to property owners or retail tenants seeking to **remove architectural barriers, renovate the commercial building façade and enhance exterior signage**. The Program's objectives are to improve accessibility and physical appearance of retail establishments and enhance commercial districts.

The Program provides a **matching grant for the funding of well-designed improvements** that will coordinate all the important features of the storefront into a more attractive image while creating an accessible entrance for the public. This may include removal of physical barriers, restoration of architectural details, better windows and doors, and well-proportioned signage and lighting. Past matching grants have ranged from \$2,500 to \$35,000 with accessible design upgrades getting 90% reimbursement based on scope of work and available funds. Grants vary each year so contact CDD for further information.

Applicants are responsible for hiring licensed designers, architects, contractors, and sign fabricators. A retail tenant is defined as a commercial establishment selling goods or services directly to members of the public for personal use and whose use is not solely for re-sale purposes (wholesale). Included in this definition are food and creative for-profit businesses.

Improvements made prior to a signed contract with the City of Cambridge will not be funded.

The following criteria must be met for participation in the Program:

1. Applicants must be property owners or commercial retail tenants whose storefronts face onto a Cambridge street;
2. Commercial retail tenants must offer goods or services that are open to the public;
3. Preference will be given to independent businesses not required by contractual arrangement to maintain standardized décor, architecture, signs or similar features;
4. Preference will be given to commercial retail tenants in a commercial district or corridor;
5. Tenants must have written approval from property owners to participate in program;
6. Billboards on property, if applicable, must be permanently removed as part of the improvement;
7. Property owners must be up to date on all municipal taxes prior to participation in the program;
8. Applicants must comply with all State and local laws and regulations pertaining to licensing, permits, building code and zoning requirements.

The City of Cambridge reserves the right to apply additional criteria before accepting a project if program demand exceeds budgeted resources.

For more information, please contact Christina DiLisio, (617) 349-4601, cdilisio@cambridgema.gov

585 Mass Ave

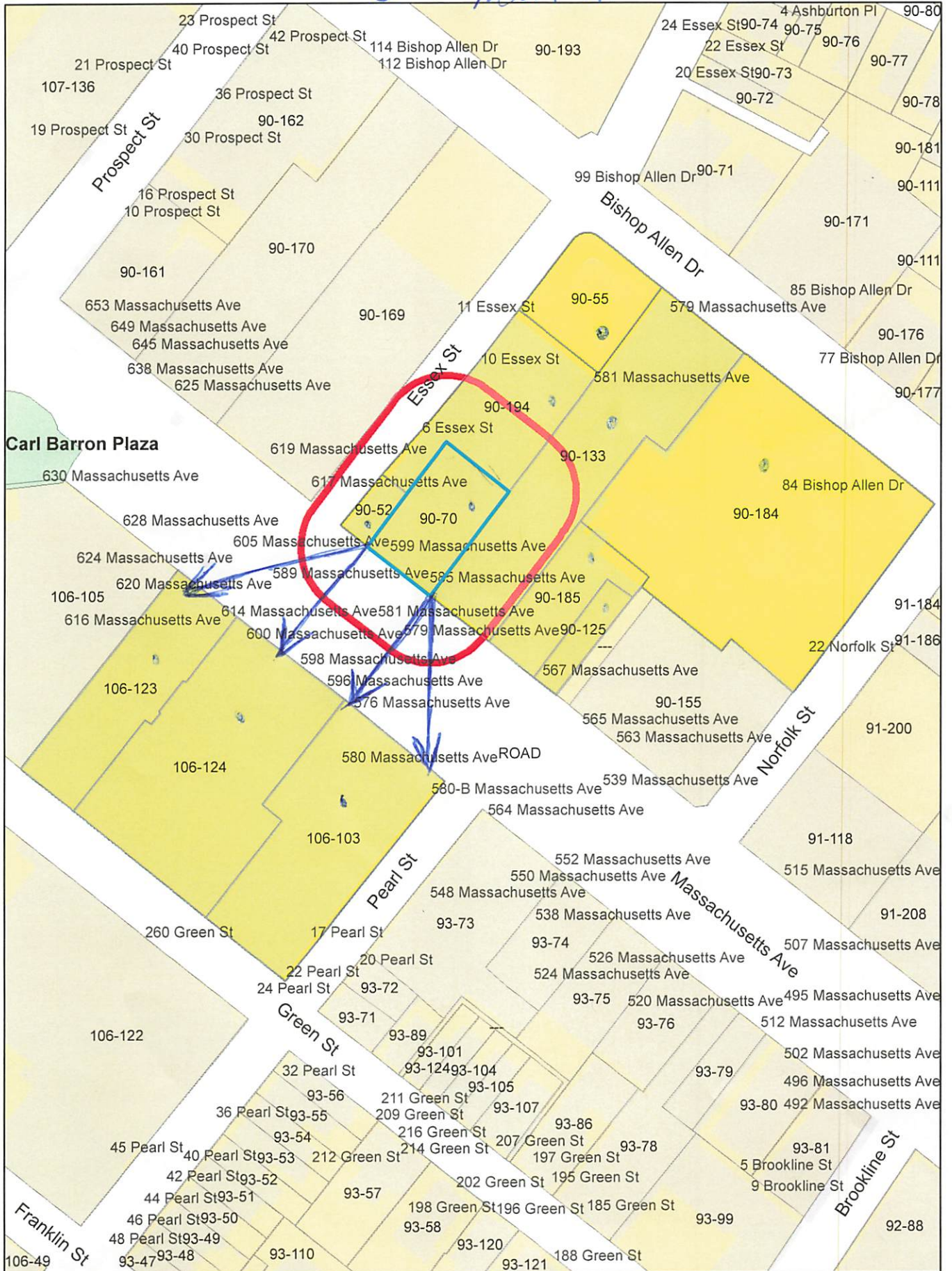

585 Mass Ave

Petitioner

106-103
ROTHMAN, GEORGE & ETHEL ROTHMAN,
C/O FIRST CAMBRIDGE REALTY
907 MASS AVE
CAMBRIDGE, MA 02139

106-124
CIFRINO-MASSACHUSETTS AVENUE REALTY LLC.
C/O SUPERIOR REALTY CO., INC.
540 GALLIVAN BOULEVARD
DORCHESTER, MA 02124

JOSEPH NAGGAR
585 MASS AVENUE
CAMBRIDGE, MA 02139

90-52-70-194-133
3MJ ASSOCIATES LLC
585 MASSACHUSETTS AVE
CAMBRIDGE, MA 02139

90-55 & 184
CITY OF CAMBRIDGE
C/O TRAFFIC & PARKING

90-55 & 184
CITY OF CAMBRIDGE
C/O YI-AN HUANG
CITY MANAGER

90-55 & 184
CITY OF CAMBRIDGE
C/O MEGAN BAYER
CITY SOLICITOR

106-123
CARU CAMBRIDGE LLC.
620 MASSACHUSETTS AVE
CAMBRIDGE, MA 02139

90-125
KATIS, HARRY N, & VICTORIA KATIS,
TRUSTEE OF POTAMIA REALTY TRUST
720 MASS AVE
CAMBRIDGE, MA 02139

90-185
575 MASS AVE LLC
585 MASSACHUSETTS AVE
CAMBRIDGE, MA 02139

1 * * * * *

2 (8:28)

3 Sitting Members: Jim Monteverde, Steven Ng, Virginia
4 Keesler, Daniel Fernando Hidalgo, and
5 Wendy Leiserson

6 JIM MONTEVERDE: Next case is 245889 -- 585 Mass
7 Avenue. Is there anyone who wishes to speak on the signage
8 issue there?

9 [Pause]

10 Is there anyone who wishes to speak on 585 Mass
11 Avenue? The signage proposal? Actually --

12 RICHARD BIGGINS: This is Richard Biggins. Can
13 you hear me?

14 JIM MONTEVERDE: Yes, we can.

15 RICHARD BIGGINS: Hi. Good evening. This is Rick
16 with Ardon Visual Communications. We're the signage vendor
17 for Dimagi and they are looking to, or they're proposing to
18 put two vertical building banners.

19 Given where they are a second- and third-floor
20 tenant, and there's not much room for signage on the ground
21 level to lead to the retail spaces, they wanted to do
22 vertical building banners so they could at least get their

1 name out there to be seen by all the many passersby on Mass
2 Ave.

3 JIM MONTEVERDE: Can you walk us through the
4 drawing that shows the banners that you're proposing?

5 RICHARD BIGGINS: Yep. So we were asked on the
6 original application to keep them in line because the
7 building steps up at three different tiers. So you've got
8 the general height of the building.

9 You can go back up to the first slide.

10 I think that leaves the overall height of the
11 banners as roughly 12'2", which brought them from yellow
12 point to yellow point, continuing that curve on the line
13 straight across the building makes it look like it goes a
14 little higher, but level wise they are in level on the
15 building.

16 If you go down to the next slide.

17 This is a photo rendering of what the proposed
18 signage would look like once it's going to be installed if
19 approved. Not really sticking out too far overall.

20 Dimension of the banner is 31" given the brackets
21 I think that's off the building, they're probably about four
22 to six inches, which pretty much keeps it in line with the

1 light boxes down at the corner of the building, which is 3'
2 light box that you can see right at the very corner.

3 So we -- nothing sticks out any further than what
4 is already on the building at various locations. There's
5 another one a little further down under the other banner
6 above Caffè -- I believe it's Caffè Nero, which stays within
7 the same projections on that end of the building as well.

8 And I think the overall square footage was just a
9 touch over -- you know, allotted square footage. But given
10 the locations of the banners, where they were much higher,
11 if we stayed within that, I believe it's 12 square feet,
12 which is what Santander has, that the much lower level is
13 kind of right behind the tree.

14 It's a little hard to see in this photo. That
15 would just look very minuscule that far up on the building,
16 and at that point the text would be relatively small and not
17 really legible from too much of a distance.

18 So the company kind of feels like they were kind
19 of losing their identity of having or doing business in that
20 area.

21 JIM MONTEVERDE: That's your presentation?

22 RICHARD BIGGINS: That is, sir. Thank you.

1 JIM MONTEVERDE: Okay. And I think that the areas
2 again, I read somewhere else in the file it's 13 square feet
3 -- I'm assuming that's each sign -- is allowed? For a total
4 -- is it 31, sorry 13 total and you're at 31.4 square feet
5 each? Is that correct?

6 RICHARD BIGGINS: Yeah, it's -- well the 13 -- I
7 believe it's 13' is the overall -- yeah, 13 or 14 square
8 feet is what's allowed. And we are --

9 JIM MONTEVERDE: Total.

10 RICHARD BIGGINS: Yeah, total. Well, per -- per
11 banner.

12 JIM MONTEVERDE: Oh, okay. Thank you.

13 RICHARD BIGGINS: Yep. Per sign. We're having
14 two of them, but they said given the location, if we stayed
15 at that height, you know, without altering their branding,
16 if I stayed at that height, that text would probably be
17 about six inches -- you know, six inches at almost 30 some-
18 odd feet, 40 some-odd feet up is very, very small.

19 And they -- the company just kind of felt like
20 they just lost their identity. So that's why we're seeking
21 the variance for this.

22 JIM MONTEVERDE: And this is for a tenant that's

1 on the second and third floor?

2 RICHARD BIGGINS: Yes.

3 JIM MONTEVERDE: Where is their entry?

4 RICHARD BIGGINS: Their entry is -- see where the
5 parking sign is?

6 JIM MONTEVERDE: Yeah.

7 RICHARD BIGGINS: In that photo? It's --

8 JIM MONTEVERDE: Yep.

9 RICHARD BIGGINS: Just to the right of that
10 there's one doorway. And another tenant already has a blade
11 sign, that little blue sign --

12 JIM MONTEVERDE: Yep.

13 RICHARD BIGGINS: -- over the door.

14 JIM MONTEVERDE: So that's the entry to the space
15 on the second and third floor?

16 RICHARD BIGGINS: Yeah. You go in there, then
17 there's a hallway, then you take an elevator up --

18 JIM MONTEVERDE: -- Okay.

19 RICHARD BIGGINS: -- to the tenant spaces.

20 JIM MONTEVERDE: Okay. Thank you.

21 Any questions from members of the Board? No? If
22 not --

1 VIRGINIA KEESLER: I was wondering if you can just
2 speak a bit to the need to have two signs rather than one
3 sign?

4 RICHARD BIGGINS: Just because they occupy that
5 much -- they occupy left to right on the second floor; third
6 floor it's occupied on the left side, middle and a portion
7 -- I think it's one window, or it's the corner office on
8 that.

9 So when that tree is kind of in bloom, when we
10 were out there the first time, it's been kind of cut back
11 down. The owner doesn't really do as much stuff. But that
12 tree definitely fills up. So they were trying to ensure
13 that it's visible from both sides. That was the reasoning
14 for it.

15 VIRGINIA KEESLER: Thanks.

16 RICHARD BIGGINS: You're welcome.

17 WENDY LEISERSON: Daniel, you're unmuted. Do you
18 have a question? I didn't want to jump in front of you.

19 DANIEL HIDALGO: No, okay. Well, I just -- you
20 know, the application form for the supporting statement for
21 the variance didn't really have any kind of -- nothing about
22 the hardship.

1 And so, I think I can heard some possible
2 candidates for the hardship -- you know, I guess something
3 to do with the fact that ground floor retail precludes the
4 -- you know, the offices from having their own signs. I
5 don't know exactly if that really fits.

6 But yeah, I just wanted to comment on the fact
7 that the application form didn't really have any kind of
8 justification.

9 RICHARD BIGGINS: Yeah. I apologize; that
10 typically one of the girls in our office handles all the
11 permitting. Most of the time it's all relatively
12 straightforward plans when we have to scan drawings and such
13 so, this didn't actually cross my desk to be filled out as a
14 variance, or else I would have included a lot of this
15 information prior to this meeting so I do apologize for
16 that.

17 JIM MONTEVERDE: Did you want to speak to that,
18 even though it's not part of the submittal. But just asking
19 for some commentary that we can support the variance
20 requirement that there be a hardship.

21 RICHARD BIGGINS: Well, the first floor, all the
22 retail tenants have pretty much all of the space wrapped up.

1 There is no space for additional signage on any of those
2 three locations. And where the one door is, there's already
3 an existing projecting sign there.

4 And if we were to put a duplicate one there, we
5 would be blocking one side of the visibility of their sign.
6 So it really becomes an issue of where can the company who
7 chews up a lot of square footage within the building, how
8 can they be identified?

9 And this was kind of the only solution. So when
10 we had the one, if you put one on one side of the building,
11 when that tree's in bloom and you're closer to the Central
12 Square area, that tree totally blocks that view.

13 So it would put one over there on the closer side,
14 but then when you're further away on the Boston side of Mass
15 Ave, because that tree is in bloom, it comes pretty close to
16 touching the windows in the summertime.

17 So they opted to ask for two, to make sure that
18 their branding and identity was covered -- you know, amongst
19 all the other businesses in the area.

20 It's -- potentially it's only a block, block and a
21 half or two right outside of Central Square, so it's a very
22 heavy commercial district, as I'm sure you guys are all well

1 aware of.

2 So that was the reason for it. And given the
3 height, the signage is really small. I mean, when you look
4 at visibility, a three-inch letter is visible, you know,
5 upwards of 10 feet up and about 15 feet away. So we're
6 almost tripling those numbers.

7 And if I were to double the height of the number,
8 I'm roughly at about a 6"- to 7"-line of text, it would be
9 -- it would be too small to be read from oncoming traffic or
10 people trying to identify where the space is.

11 WENDY LEISERSON: I'd like to jump in. Do you see
12 the green sign that's above Caffè Nero underneath your
13 proposed location for the sign?

14 RICHARD BIGGINS: I do.

15 WENDY LEISERSON: Is that a compliant sign?

16 RICHARD BIGGINS: I can't speak on that. I don't
17 know if that's compliant or --

18 WENDY LEISERSON: I mean, it looks to me from the
19 photo -- and obviously, it's imperfect that it's not
20 exceptionally larger. And actually, it may even be the same
21 size as the first floor signs that we see; the blue sign and
22 the light box that you called attention to --

1 RICHARD BIGGINS: Yep.

2 WENDY LEISERSON: Yep.

3 JIM MONTEVERDE: Yep.

4 WENDY LEISERSON: So I guess I'm having trouble
5 understanding why -- first of all why you need two, when the
6 Ordinance prescribes one as the maximum.

7 And also, these signs are not helping the person
8 on the street to find the entrance to your door, because the
9 entrance to your building is where the blue sign is on the
10 first level, where your banners are.

11 RICHARD BIGGINS: The landlord has given them
12 permission to put a vinyl graphic on the door --

13 WENDY LEISERSON: Mm-hm.

14 RICHARD BIGGINS: -- with their name.

15 STEVEN NG: Well that's -- is that -- that's not
16 part of this application, is it?

17 RICHARD BIGGINS: Nope. They were going to seek
18 that after the banners. They wanted to --

19 WENDY LEISERSON: It's just I want to call
20 attention to the Board that the purposes of this Ordinance
21 are to reduce visual clutter. And, like, I don't see a
22 purpose that includes helping businesses to brand

1 themselves.

2 I do think that there's something to be said for
3 navigating and helping people navigate around the city. But
4 this seems a lot to ask, given what the Ordinance's purposes
5 are for signs.

6 But I'll leave it at that time for now, and
7 welcome to hear others' opinions.

8 JIM MONTEVERDE: Any other questions from members
9 of the Board? We'll get to discussion in a moment. If not,
10 we have one correspondence in the file -- two, actually.
11 One from a Mason Wells. He's an Associate Zoning Planner
12 for the Cambridge Community Development Department.

13 He writes that he solicited written feedback from
14 members of the Central Square Advisory Committee. He
15 received one comment from Christopher Fort, which I'll read
16 in a second. And no formal recommendation was made by the
17 Central Square Advisory Committee.

18 The one who did write -- this is Christopher Fort;
19 this is from November 27 -- says -- I'll read this one. It
20 looks at the documents -- it looked at the documents in the
21 Google Street view of the area:

22 "At first, the size of the sign seemed out of

1 place, but there are more signs sticking out perpendicular
2 to buildings in Central Square than I remember.

3 As long as the 31" is in line with the usual depth
4 of these signs, I don't see any reason why Dimagi shouldn't
5 be allowed to have this sign."

6 And that is the correspondence in the file.

7 I will open this to public comment. Any member of
8 the public who wishes to speak should now click the icon at
9 the bottom of your Zoom screen that says, "Raise hand."

10 If you're calling in by phone, you can raise your
11 hand by pressing *9 and unmute or mute by pressing *6.

12 I'll now ask Staff to unmute speakers one at a
13 time. You should begin by saying your name and address, and
14 Staff will confirm that we can hear you. After that you
15 will have up to three minutes to speak before I ask you to
16 wrap up.

17 JAMES WILLIAMSON: Can you hear me?

18 JIM MONTEVERDE: Yep.

19 JAMES WILLIAMSON: Should I go ahead?

20 JIM MONTEVERDE: Yep. Can you --

21 JAMES WILLIAMSON: So this is James Williamson, at
22 30 Churchill Ave in Cambridge. And first of all, I track

1 the meetings of the Central Square Advisory Committee pretty
2 closely. It's possible that I overlooked something. But I
3 do often attend, and there is often an opportunity for some
4 public comment, which can sometimes lead to certain
5 perspectives being included in any report.

6 It's not clear to me whether there was -- this was
7 actually discussed at a meeting of the Cambridge Historical
8 Commission, or whether there was just a sort of a private e-
9 mail sent around to members for their comment. I just think
10 that warrants clarification.

11 And in fact, I would hope that in the future they
12 actually include the discussions about a proposal like this
13 at their meeting, so that the public can be aware of it and
14 have an opportunity.

15 I may be mistaken. It may have been an agenda
16 item; I just didn't notice it.

17 I wish that Carol O'Hare were here to provide some
18 -- her perspective and guidance on it's not exactly the
19 typical branding sign that we have heard a lot about on the
20 big high-rises, the big corporate buildings in for example
21 Kendall.

22 But we heard already some commentary about

1 branding. And not sure exactly what the letter of the
2 Ordinance is now in terms of above 20'.

3 But I think that a more modest sign -- I'd be
4 interested, by the way, if the Historical Commission were
5 asked about this if they signed off on it. I think there's
6 an argument to be made for the historic buildings. Central
7 Square is a Historic District, nationally recognized. I
8 don't know the exact term.

9 But I'm not sure that given the historic character
10 of the buildings in Central Square, whether this kind of
11 signage is really such a great idea.

12 I do share what I think is behind some of the
13 questions that have already been asked, that to have first
14 of all a more modest sign I think would be worth
15 considering.

16 And the idea of having these two signs at either
17 end of a building that includes other businesses is -- you
18 know, just a little jarring in that it sort of presents a
19 notion -- and symbiotically -- of the entire building being
20 encompassed by this brand and this one company, which is not
21 the fact. It's not the fact, even not on the two upper
22 floors.

1 So I think that's a little bit much for -- they're
2 going for a little bit much.

3 And I -- so basically, I think, you know, one sign
4 if it's appropriate and modest, should be more than enough
5 in this location. And I'd certainly like to hear whether
6 the Historical Commission had an opportunity to weigh in
7 what they might have -- what their view of this might have
8 been if they had a hearing. I don't know that they did.

9 Thank you.

10 JIM MONTEVERDE: Thank you, James. Anyone else?

11 STEPHEN NATOLA: 6178311.

12 HEATHER HOFFMAN: Hello. Heather Hoffman, 213
13 Hurley Street. And I won't do as good a job as Carol
14 O'Hare area would have done, were she here. But I think
15 Wendy Leiserson said most of what needs saying.

16 It's -- and also James's point about just the kind
17 of proprietariness (sic) of making it look as though this
18 business is the whole building is a reasonable one.

19 I'm a firm believer in having signs that help
20 people find places. They certainly help me. But I think
21 that, as the petitioner said, this is for branding. This is
22 turning this building into a billboard for this business.

1 And I don't think that's necessary. I think that
2 we have done a really good job of making signs perform their
3 major purpose, which is helping find a place then we don't
4 need billboards.

5 So I suspect that there's a good place to put one
6 sign on this building so the people can -- who need to find
7 this business can find it. And I hope that they will
8 rethink their land grab here and go for the one sign in a
9 good place.

10 Thank you very much.

11 JIM MONTEVERDE: Thank you, Heather. Anyone else?
12 That's it for public testimony. So I'll close public
13 testimony.

14 Discussion among members of the Board?

15 STEVEN NG: Yeah. This is Steve Ng. I think the
16 current signage bylaw requirements are appropriate for the
17 street level like retail spaces. You can see the band
18 between the first and second floor where the blade sign,
19 which would be to meet 13 square feet or so -- yeah, 3' x 3'
20 or something in that range -- is visible. It identifies
21 where a retail outlet goes. And I think it works really
22 well I think in a Central Square situation or context.

1 The corporate identity stuff for the tenant,
2 that's a whole nother design factor or something I think
3 that needs to be considered. I mean, you remember the other
4 applications of corporate identity in Cambridge. And it's
5 always a pretty tough battle.

6 Even though this is a commercial area, I think to
7 go two-and-a-half times larger than that bylaw, and then at
8 the same time two signs, and then even higher than the range
9 of where their space is located seems to be a little heavy-
10 handed. I think the public comment is similar. I'm
11 sympathetic to their thoughts on that.

12 I mean, if the Board isn't considering maybe one
13 location a blade sign over the entrance door, like it would
14 be between second and third floor, but just above where
15 their doorway is -- I think it's within the Caffè Nero
16 storefront -- I think that's probably the most I'd be
17 willing to support.

18 JIM MONTEVERDE: Thank you. I feel I have similar
19 sentiments. At the moment, in what's presented, I would not
20 be in favor. And I think, Steven, if -- from what you said,
21 you feel the same. That's two out of the five, and that's
22 enough to deny this if we go further.

1 So anyone else have any discussion before I make a
2 proposal to the proponent?

3 WENDY LEISERSON: I would like to see -- this is
4 probably maybe outside the scope of our discussion, but it
5 seems to me if the role of the Zoning rules about signage
6 are to reduce clutter, and there are so many signs on this
7 building, it would be nice if the landlord and the tenants
8 could get together and make a uniform, you know, shape and
9 system --

10 STEVEN NG: Yeah.

11 WENDY LEISERSON: -- with the different -- I feel
12 like that would be very attractive to that building and the
13 tenants, if there was some uniformity in the type of signs
14 there. But that just my comment.

15 But I'm inclined to follow Steve and Jim's
16 leaning.

17 JIM MONTEVERDE: Okay. Thank you. Any other
18 discussion from members of the Board?

19 VIRGINIA KEESLER: I agree that the number of
20 signs starts to look a bit cluttered, and having two signs
21 seems excessive. I'm less bothered by the size of the sign
22 if it's higher. But I generally -- I agree with the

1 sentiments already expressed by the fellow members.

2 DANIEL HIDALGO: Yeah. I basically, along with
3 what Virginia's saying, I actually don't mind one of those.
4 And I think that serves some purpose that it's identified
5 that businesses in the building. So I don't necessarily
6 need it to be right where the entrance is, but yeah. Two
7 seems, you know, excessive to me.

8 JIM MONTEVERDE: Okay. So I think for the
9 proponent, if you've heard the discussion among the Board
10 members, that's by my count five against, if we go to a
11 vote, which is a denial.

12 So I think your options are either we proceed to a
13 vote, and you be denied, in which case you can't come back
14 within a two-year period with something the same proposal --
15 or you can withdraw, we can continue, we can come back.

16 Think about this, revise this, look at the
17 Ordinance, look at your options to do something that's
18 within the 20' height, so it's closer to the -- at or closer
19 to the allowed square footage -- come up with a revised
20 proposal and present it at another time.

21 Do you have a preference?

22 RICHARD BIGGINS: If we go to a vote, and

1 obviously by the feel of the conversation, it would get
2 denied, if they resubmit as a new sign, since that wouldn't
3 be within that two-year timeframe, because it would be a new
4 application, a new sign, new layout, that would be
5 completely brand new again, correct?

6 JIM MONTEVERDE: It would have to be significantly
7 different.

8 RICHARD BIGGINS: Well --

9 JIM MONTEVERDE: Otherwise, it's a repetitive
10 petition.

11 RICHARD BIGGINS: Let me just make sure I'm
12 understanding correctly. If I'm being told to stay within
13 the 12 square feet, then it's going to be drastically
14 different, given the comments of the Board. Because it
15 seems everyone feels this is drastically oversized and
16 multiple, so --

17 JIM MONTEVERDE: Yep.

18 RICHARD BIGGINS: -- if I'm reducing -- reducing
19 the overall size by a fair amount and then changing the
20 overall shape of the design -- because that is what really
21 chews into the square footage of the -- I'm being forced to
22 take into consideration the fabric, not just with a word

1 again.

2 Like, if we look at Caffè Nero, you know Caffè
3 Nero's square footage is technically larger than my banner.
4 Given that's only one not for instance two, but the ground
5 floor tenants have more square footage of the signage base
6 than the -- than the one.

7 Obviously, I'm not comparing it against two signs,
8 just comparing it against one. It just so happens that
9 there is no space for that type of square footage flat
10 against the wall, and -- you know, where these kind of
11 broken off, they're -- like, typically designed, I would
12 think the bylaws typically designed for most businesses to
13 have ground level storefronts with wall signage.

14 And they typically usually put a 2 x 4 or a 3 x 4
15 blade sign; that's where that 12' kind of thumb (sic) comes
16 in, I -- like the lightbox on the corner. And it's not
17 really taken into consideration for vertical building
18 banners.

19 And the intention of this wasn't to brand the
20 building or make it feel like a billboard, it was just for
21 the company to be able to advertise that they are in the
22 building, since there's really not much room for them to do

1 so.

2 And given their name, the way their logo goes, if
3 you turn that 90 degrees, once you get off at 4', you're
4 talk about, like 3" of text, 2" of text. It's not very big.

5 So they don't have the walls -- they don't have
6 the wall area to come up with that type of a signage. So
7 this is why they went that route.

8 WENDY LEISERSON: I'm sorry, Mr. --

9 JIM MONTEVERDE: Wendy?

10 WENDY LEISERSON: -- Chair. Yes. I was just
11 wondering whether we were hearing more argument at this
12 point, or whether we were --

13 JIM MONTEVERDE: No. I --

14 WENDY LEISERSON: -- hearing --

15 JIM MONTEVERDE: Yeah. I was going to say the
16 discussion really is -- the presentation is completed. It's
17 over. And we're at the point when I asked you is your
18 option is in terms of what kind of motion do we make?

19 And the sense from the Board members is there --
20 we would be prepared to -- you would have enough negative
21 votes that you would be denied.

22 And like I said, you couldn't come back within a

1 two-year period with the same or similar proposal. Or we
2 can continue this for you. You can come back, and come back
3 with hopefully your revised scheme, and we'll review it
4 again. That's what we're talking about.

5 You have to make a choice or -- it's time for you
6 to make a choice. I can't make it for you.

7 RICHARD BIGGINS: Okay. Can we please continue?
8 I'll have to go back to the client. I don't want to --

9 JIM MONTEVERDE: Yeah.

10 RICHARD BIGGINS: -- give the client the foot
11 right now.

12 JIM MONTEVERDE: Okay. We can do -- would January
13 11 give you enough time to --

14 RICHARD BIGGINS: Yes. That would be sufficient.

15 JIM MONTEVERDE: Okay. Let's do that.

16 So make a motion -- hold on one second, please.

17 Let me make a motion to continue this matter to January 11,
18 2024 on the condition that the petitioner change the posting
19 sign to reflect the new date of January 11, 2024 and the
20 time of 6:00 p.m.

21 Also that the petitioner sign a waiver to the
22 statutory requirements for the hearing. This waiver can be

1 obtained from Maria Pacheco or Olivia Ratay at the
2 Inspectional Services Department.

3 I ask that you sign the waiver and return it to
4 the Inspectional Services Department by a week from this
5 coming Monday.

6 Failure to do so will de facto cause this Board to
7 give an adverse ruling on this case.

8 Also, that if there are any new submittals,
9 changes to the drawings, dimensional forms, or any
10 supporting statements that those be in in the file by 5:00
11 p.m. on Monday prior to the continued meeting date.

12 On the motion to continue the matter until January
13 11, 2024 on a voice vote from the Board members, Virginia?

14 VIRGINIA KEESLER: In favor.

15 JIM MONTEVERDE: Wendy Leiserson?

16 WENDY LEISERSON: In favor.

17 JIM MONTEVERDE: Thank you. Steven Ng?

18 STEVEN NG: In favor.

19 JIM MONTEVERDE: Thank you. Daniel?

20 DANIEL HIDALGO: In favor.

21 JIM MONTEVERDE: Thank you. And Jim Monteverde in
22 favor.

1
2
3
4
5
6
7
8
9
10
11
12
13
14
15
16
17
18
19
20
21
22

[All vote YES]

JIM MONTEVERDE: That's five in favor. The matter is continued until January 11, 2024.

RICHARD BIGGINS: All right. Good evening, everybody. Thank you. I appreciate it.

JIM MONTEVERDE: Thank you.



City of Cambridge

MASSACHUSETTS

BOARD OF ZONING APPEAL

831 Mass Avenue, Cambridge, MA.
(617) 349-6100

2023 DEC 13 PM 3:36

OFFICE OF THE CITY CLERK
CAMBRIDGE, MASSACHUSETTS

Board of Zoning Appeal Waiver Form

The Board of Zoning Appeal
831 Mass Avenue
Cambridge, MA 02139

RE: Case # BZA-245889

Address: 585 Mass Avenue

Owner, Petitioner, or Representative: Joseph Naggari
(Print Name)

hereby waives the required time limits for holding a public hearing as required by Section 9 or Section 15 of the Zoning Act of the Commonwealth of Massachusetts, Massachusetts General Laws, Chapter 40A. The Owner, Petitioner, or Representative further hereby waives the Petitioner's and/or Owner's right to a Decision by the Board of Zoning Appeal on the above referenced case within the time period as required by Section 9 or Section 15 of the Zoning Act of the Commonwealth of Massachusetts, Massachusetts General Laws, Chapter 40A, and/or Section 6409 of the federal Middle Class Tax Relief and Job Creation Act of 2012, codified as 47 U.S.C. §1455(a), or any other relevant state or federal regulation or law.

Date: 12/1/23

James Ernst
Signature

Pacheco, Maria

From: Wells, Mason
Sent: Wednesday, November 29, 2023 4:33 PM
To: Pacheco, Maria
Cc: Janice Ernst; Kane, Drew; Messplay, Daniel
Subject: Central Square Advisory Committee Comments on 585 Mass Ave BZA Case
Attachments: CSAC Member Comment - Christopher Fort - 585 Mass Ave - 20231127.pdf

Hi Maria,

I solicited written feedback from members of CSAC on the 585 Mass Ave BZA case. I received one comment from Christopher Fort that is attached for consideration by the BZA.

No formal recommendation was made by CSAC.

Please let me know if you have any questions.

Thank you,
Mason

Mason Wells

he/him/his

Associate Zoning Planner

Cambridge Community Development Department

344 Broadway, Cambridge, MA. 02139

mwells@cambridgema.gov

Re: CSAC Mtg Confirmed December 6th

Christopher Fort <christopher.fort@gmail.com>

Mon 11/27/2023 12:18 PM

To: Wells, Mason <mwells@cambridgema.gov>

Hi Mason,

I looked at the documents and the Google Street View of the area. At first, the size of the sign seemed out of place, but there are more signs sticking out perpendicular to buildings in Central Square than I remembered. As long as the 31" is in line with the usual depth of these signs, I don't see any reason Dimagi shouldn't be allowed to have this sign.

Best,
Chris

On Wed, Nov 22, 2023 at 2:40 PM Wells, Mason <mwells@cambridgema.gov> wrote:

Hi everyone,

Thanks for getting back to us about our upcoming CSAC meeting. Based on the mix of feedback and the short timeline we will go ahead with our regularly scheduled December 6th meeting. **We will not schedule a special meeting for November 29th.**

Please email me and Drew directly with **any comments on the 585 Mass Avenue case** (materials attached to this email). If it's easier, I'm also happy to take anyone's comments over a quick phone call. Just let me know.

The main focus of our December 6th meeting will be an update on the Central Square Lot Study. I'll follow up next week with meeting details and materials.

I hope you all have a wonderful Thanksgiving!

Cheers,
Mason

Mason Wells

he/him/his

Associate Zoning Planner

Cambridge Community Development Department

344 Broadway, Cambridge, MA. 02139

mwells@cambridgema.gov



City of Cambridge

MASSACHUSETTS

BOARD OF ZONING APPEAL

831 Mass Avenue, Cambridge, MA.
(617) 349-6100

BZA

POSTING NOTICE - PICK UP SHEET

The undersigned picked up the notice board for the Board of Zoning Appeals Hearing.

Name:

Sanic-Fox
Jamie Ernst

(Print)

Date:

11/16/2023

Address:

585 Mass Ave

Case No.

245889

Hearing Date:

11/30/23

Thank you,
Bza Members

1 * * * * *

2 (6:03 p.m.)

3 Sitting Members: Jim Monteverde, Steven Ng, Virginia
4 Keesler, and Wendy Leiserson

5 JIM MONTEVERDE: The first case I'm going to call
6 is a continued case, and it is BZA 245889 -- 585
7 Massachusetts Avenue. Is there anyone wishing to speak on
8 this case?

9 [Pause]

10 Let's give them a minute.

11 So if you all remember, this is the signage on the
12 building in Central Square, the banners. We -- this case
13 was continued. That was no one came in for the continued
14 session, and this is the second continued.

15 So if they don't -- no one arrives, shows up, then
16 with the four of us, I will recommend that we vote to deny
17 without prejudice.

18 Does this allow them to come back?

19 STEPHEN NATOLA: Someone's --

20 JIM MONTEVERDE: Yeah. Let's see who it is. We
21 have someone who's calling in. We'll see if this is the
22 proponent or --

1 STEVEN NATOLA: Sarah Nabulsi?

2 SARA NABULSI: Yes, that's correct. Hello,
3 everybody.

4 JIM MONTEVERDE: Hi. Can you tell us your name --

5 SARAH NABULSI: Yes, absolutely. My name is Sarah
6 Nabulsi. I am an individual contributor for the location at
7 585 Massachusetts Avenue.

8 We are advocating to have two of the banners
9 placed on the third and/or fourth floor of the building. We
10 have a landlord approval letter.

11 We have two main entrances to our building, which
12 reading the code -- City of Cambridge code, it does allow us
13 to have the two. I understand that they are bigger in size
14 because this is due to -- because of the placement of where
15 we're looking to have the banners placed.

16 JIM MONTEVERDE: Yep. Yeah. Can I interrupt you
17 a second? So --

18 SARAH NABULSI: Yeah.

19 JIM MONTEVERDE: We went through all of this.

20 SARAH NABULSI: Okay.

21 JIM MONTEVERDE: Let me find the date. When was
22 this? This is February 8, it's tonight. I'm sorry, I'm not

1 finding the date of the original -- oh, it was November 30.

2 SARAH NABULSI: Okay.

3 JIM MONTEVERDE: And we went through the
4 presentation. The proponent walked us through the
5 presentation. We stated concerns, give them a couple
6 options on how to proceed, and the proceed was to continue
7 this case.

8 SARAH NABULSI: Yes.

9 JIM MONTEVERDE: And that would mean we would
10 expect to see something new in the file, a revision, a
11 change.

12 SARAH NABULSI: Okay.

13 JIM MONTEVERDE: There is nothing in the file.
14 Nothing's been submitted by the due date. And are you
15 explaining to us the original proposal?

16 SARAH NABULSI: I apologize. Yes, sir, I am. I
17 -- we hired vendors, which is Art and Visual, who did the
18 initial presentation to you all. So --

19 JIM MONTEVERDE: Yep.

20 SARAH NABULSI: I am just here to try to help
21 advocate for us getting the banners.

22 JIM MONTEVERDE: Well, we've had this -- you

1 really have to get -- I think I would suggest --

2 SARAH NABULSI: Yes, sir.

3 JIM MONTEVERDE: -- you get the transcript of the
4 November 30 meeting --

5 SARAH NABULSI: Okay, yes, sir.

6 JIM MONTEVERDE: -- and go through it and the
7 questions that were raised and we expected to see, if in
8 fact the proponent wanted to continue with this discussion,
9 is to have some revision through the initial proposal, not a
10 representation of the initial proposal, submitted at the
11 appropriate time before this meeting date, so that we can
12 hear it.

13 SARAH NABULSI: Okay, I --

14 JIM MONTEVERDE: So if you're the one who will be
15 following -- will you be the one following this up?

16 SARAH NABULSI: I will be, going forward, yes,
17 sir.

18 JIM MONTEVERDE: So what I would suggest is -- and
19 we've continued -- this is the second continuance. So
20 typically, we deny you at this point, but since you're here,
21 if you'd like us to continue this one more time, I'd be
22 happy to do that.

1 SARAH NABULSI: I very much appreciate that. I
2 would greatly appreciate that, as I was not aware that there
3 was a first continuance. I initially thought this was the
4 first one.

5 JIM MONTEVERDE: Nope. This is -- and again, even
6 if it was the first continuance, we expect --

7 SARAH NABULSI: You're looking for a revision.

8 JIM MONTEVERDE: -- we did not receive anything in
9 the file to modify what the original presentation was.

10 SARAH NABULSI: Yes, sir. I understand --

11 JIM MONTEVERDE: -- which is typical.

12 SARAH NABULSI: I will go back to the transcripts.
13 May you please reiterate where I can find that at?

14 JIM MONTEVERDE: If you can contact Maria Pacheco
15 at the Inspectional Services Department, give her a call,
16 and send her an email.

17 SARAH NABULSI: Maria Pacheco?

18 JIM MONTEVERDE: And I think -- yeah. I don't
19 know that it's available online. But ask Maria.

20 SARAH NABULSI: Okay, for the November --

21 JIM MONTEVERDE: All right?

22 SARAH NABULSI: -- 30 transcript. Yes, sir.

1 Thank you so much. I very much appreciate it and I --

2 JIM MONTEVERDE: Wait, wait.

3 SARAH NABULSI: -- apologize for wasting --

4 JIM MONTEVERDE: We're not done.

5 SARAH NABULSI: -- your time.

6 JIM MONTEVERDE: We're not done.

7 SARAH NABULSI: Oh.

8 JIM MONTEVERDE: We have to set a date for it.

9 SARAH NABULSI: Sure thing. Yes, sir.

10 JIM MONTEVERDE: We can do -- the next opportunity
11 is February 29.

12 SARAH NABULSI: Okay.

13 JIM MONTEVERDE: Or March 14, whatever your
14 preference is. And then let's see if the -- let me know
15 which one works for you, and then we'll check and see if
16 these Board members are available.

17 SARAH NABULSI: Yes, sir. March 14 would be the
18 best, so I may be able to work with our vendor.

19 JIM MONTEVERDE: That's good. Wendy, does that
20 work for you?

21 WENDY LEISERSON: Yes.

22 JIM MONTEVERDE: Steven?

1 STEVEN NG: Yes. That date's fine.

2 JIM MONTEVERDE: Virginia? Yes, Virginia?

3 VIRGINIA KEESLER: Yes, that works for me.

4 JIM MONTEVERDE: Okay. And it works for me. And
5 we'll contact Daniel, I think, and see if he can make it.

6 JIM MONTEVERDE: All right. Let me make a motion
7 to continue. Let me make a motion to continue this matter
8 until March 14, 2024, on the condition that the petitioner
9 change the posting sign to reflect the new date of March 14,
10 2024, and the new time of 6:00 p.m.

11 Also, that the petitioner sign a waiver to the
12 statutory requirements for the hearing. This waiver can be
13 obtained from Maria Pacheco or Olivia Ratay at the
14 Inspectional Services Department.

15 I ask that you sign the waiver and return it to
16 the Inspectional Services Department by a week from this
17 coming Monday. Failure to do so will de facto cause this
18 Board to give an adverse ruling on this case.

19 Also, that if there are any new submittals,
20 changes to drawings, dimensional forms, or any supporting
21 statements, that those be in the file by 5:00 p.m. on the
22 Monday prior to the continued meeting date.

1 On the motion to continue this matter until March
2 14, 2024, Wendy?

3 WENDY LEISERSON: In favor.

4 JIM MONTEVERDE: Virginia?

5 VIRGINIA KEESLER: In favor.

6 JIM MONTEVERDE: Steven?

7 STEVEN NG: In favor.

8 JIM MONTEVERDE: Thank you. Jim Monteverde in
9 favor.

10 [All vote YES]

11 JIM MONTEVERDE: That's four in favor; the motion
12 is carried, and the case is continued.

13 Now, is the caller still on the line?

14 SARAH NABULSI: Yes. I am still here.

15 JIM MONTEVERDE: Okay. Sarah?

16 SARAH NABULSI: Yes.

17 JIM MONTEVERDE: Just if you heard the motion --

18 SARAH NABULSI: Yes, sir.

19 JIM MONTEVERDE: -- you've got to change the sign
20 that should be posted up on the property to reflect the new
21 date and the new time of 6:00 p.m., sign a waiver -- you'll
22 get that from the Inspectional Services Department -- and

1 then any new drawings, and we expect something new, or some
2 response to the comments from the Board previously, has to
3 be filed by 5:00 p.m. on the Monday prior to the meeting
4 date. Okay?

5 SARAH NABULSI: Yes, sir. Thank you very much.
6 Thank you all. I very much appreciate your time.

7 JIM MONTEVERDE: Thank you. Now we have to wait
8 until 6:30.

9 SARAH NABULSI: Sorry for making it so fast.

10
11
12
13
14
15
16
17
18
19
20
21
22

1
2
3
4
5
6
7
8
9
10
11
12
13
14
15
16
17
18
19
20
21
22

* * * * *

(6:30 p.m.)

Sitting Members: Jim Monteverde, Steven Ng, Virginia
Keesler, Wendy Leiserson, and Thomas
Miller

JIM MONTEVERDE: Just to confirm forth evening we
have myself, Jim Monteverde; Virginia, you're still with,
correct?

VIRGINIA KEESLER: That's correct.

JIM MONTEVERDE: Steven, are you with us?

STEVEN NG: Steven Ng, present.

JIM MONTEVERDE: Yep. Thank you. Wendy?

WENDY LEISERSON: Present.

JIM MONTEVERDE: Thank you. And Tom?

THOMAS MILLER: Present.

JIM MONTEVERDE: Excellent. Okay. We're good to
go.

The first case on the Regular Agenda is BZA-252574
-- 83 Winter Street.

Is there anyone wishing to speak on this case?

DUO(ALAN) YU: Good evening, Board. So this is
Alan Yu. I'm the Project Architect. And I'm here with our

Proposed View of Property



Existing View of Property

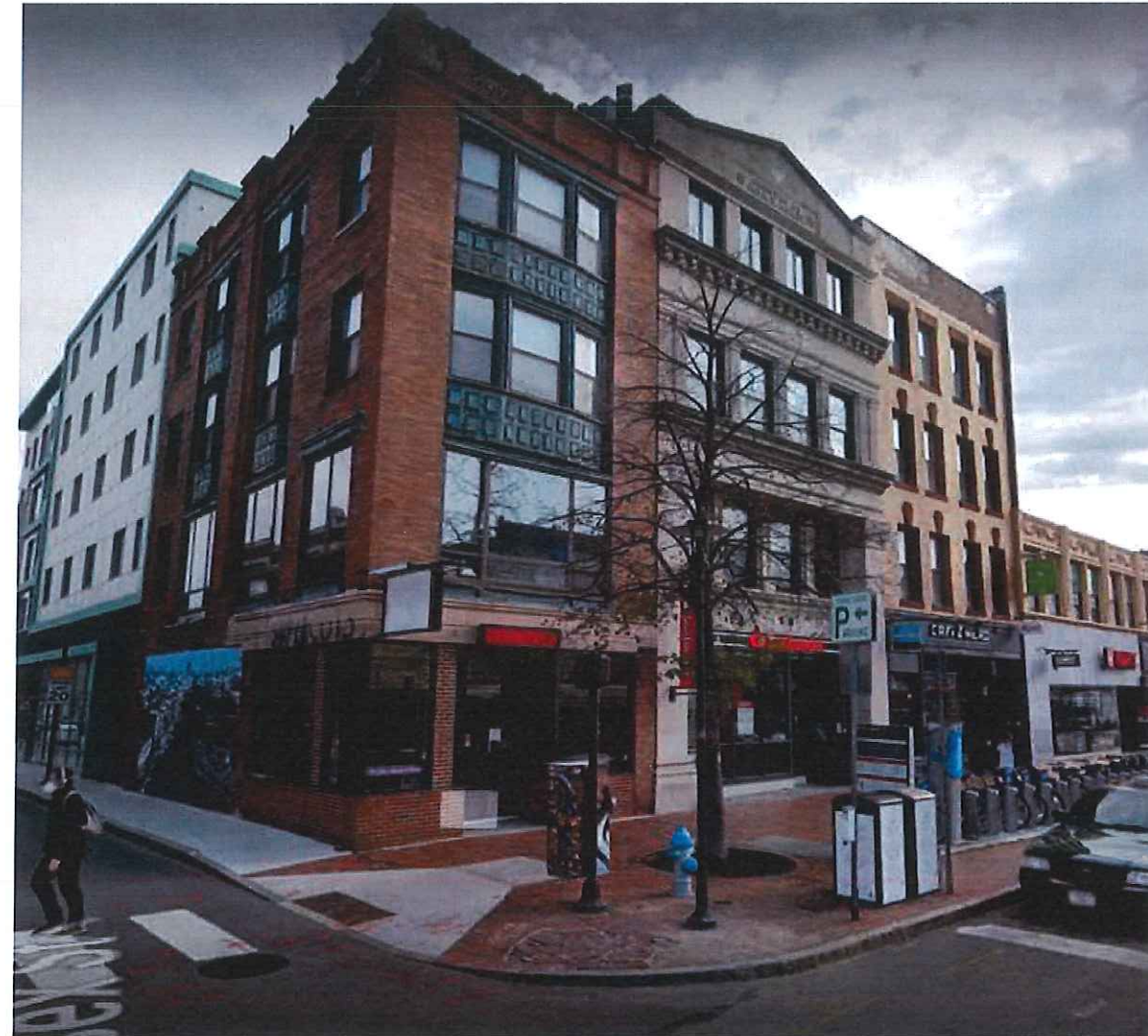

Project Title:
Dimagi - Mass Ave. Cambridge

Date: 2/27/2024

Project Contact
Sarah Nabulsi

General Sign Specifications
 Interior Exterior
 Single Faced Double Faced
 Tension fit - Building Banner
 Non-Illuminated Illuminated
 UL Labels # _____ NA
 # of UL Sections _____ of _____
 Incoming _____ Volts _____ Amps(+/-)
 Location EXT. Windspeed 110+/-

Drawing Revisions

Drawn By	Date	Change
△ RMB	2/27/2024	Revised scaling & Qty reduced
△		
△		
△		
△		
△		
△		
△		
△		
△		

- Approved, as is
- Approved, w/ changes
- Requires New Layout
- Rejected

Authorized Signature of Approval _____

Title _____

Date Signed _____

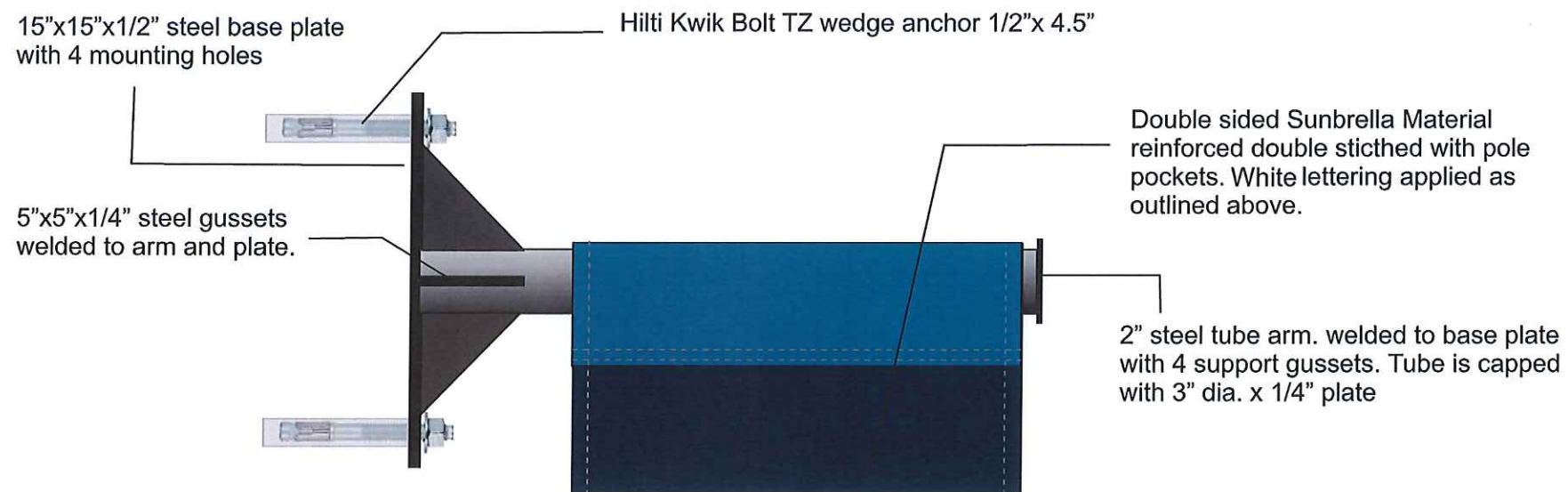

See plate details on pg.2



Electrical

*SIGN MEETS NEC 600 ELECTRICAL REQUIREMENTS. 20 amp weatherproof electrical disconnect required for every 16 amps of signage. Actual number of circuits to be determined by a licensed electrical contractor.
 Actual location of box may vary.
 Input voltage - 120V.
 All signage will be (U.L.) 48STD compliant.

Project Title:
Dimagi - Mass Ave. Cambridge

Date: 2/27/2024

Project Contact:
Sarah Nabulsi

General Sign Specifications
 Interior Exterior
 Single Faced Double Faced
 Tension fit - Building Banner
 Non-Illuminated Illuminated
 UL Labels # _____ NA
 # of UL Sections _____ of _____
 Incoming _____ Volts _____ Amps(+/-)
 Location EXT. Windspeed 110+/-

Drawing Revisions

Drawn By	Date	Change
▲ RMB	2/27/2024	Revised scaling & Qty reduced
▲		
▲		
▲		
▲		
▲		
▲		
▲		
▲		

- Approved, as is
- Approved, w/ changes
- Requires New Layout
- Rejected

Authorized Signature of Approval _____

Title _____

Date Signed _____

Electrical
 *SIGN MEETS NEC 600 ELECTRICAL REQUIREMENTS.
 20 amp weatherproof electrical disconnect required for every 16 amps of signage. Actual number of circuits to be determined by a licensed electrical contractor.
 Actual location of box may vary.
 Input voltage - 120V.
 All signage will be (U.L.) 48STD compliant.

Bottom Plate detail and tension bar

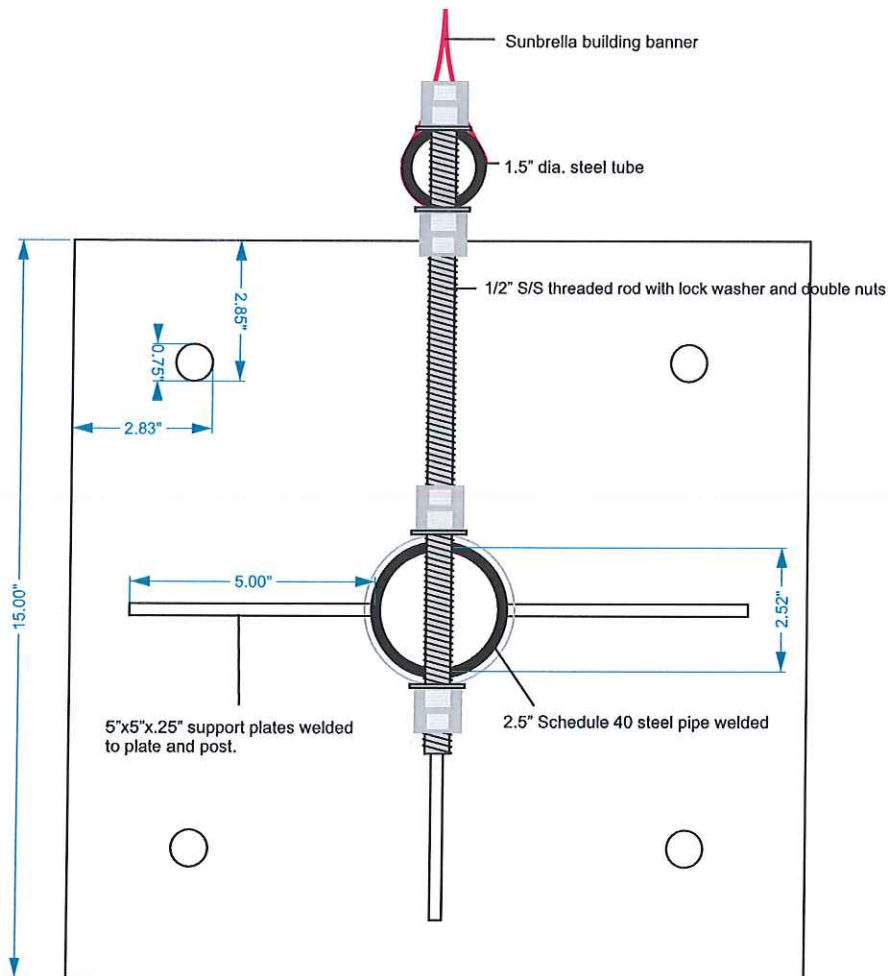

Top Plate detail and tension bar

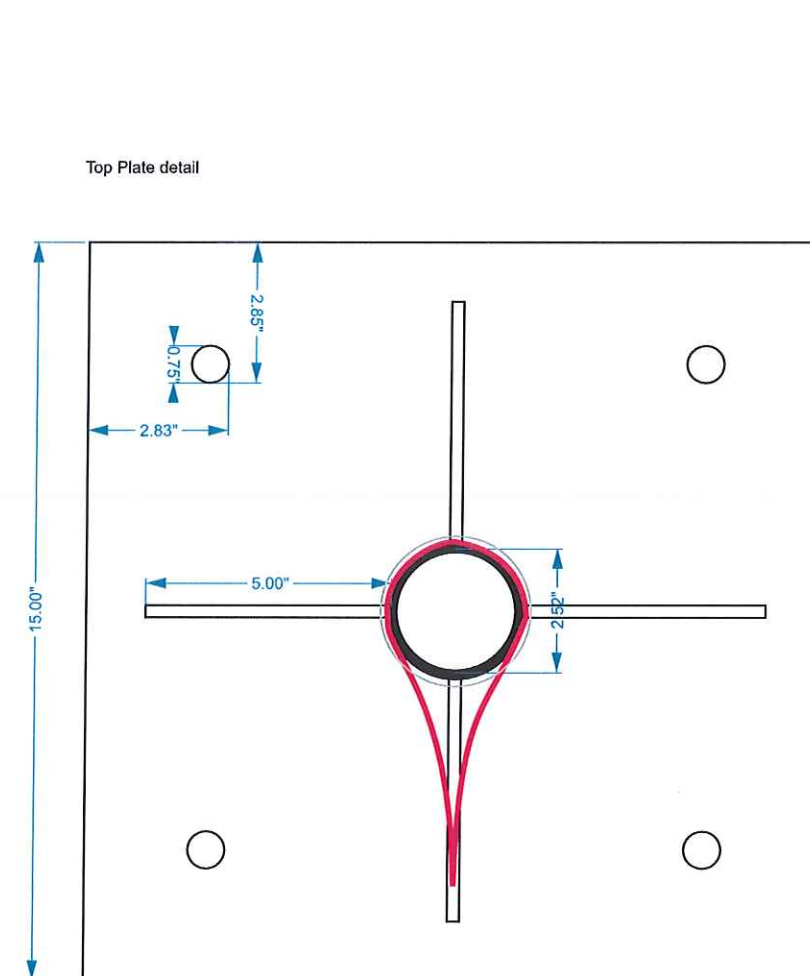

Banner area = 31.4sf





42'

28' Base of Banner above Grade

Project Title:
Dimagi - Mass Ave. Cambridge

Date: 2/27/2024

Project Contact:
Sarah Nabulsi

General Sign Specifications
 Interior Exterior
 Single Faced Double Faced
 Tension fit - Bulking Banner
 Non-Illuminated Illuminated
 UL Labels # _____ NA
 # of UL Sections _____ of _____
 Incoming _____ Volts _____ Amps(+/-)
 Location EXT. Windspeed 110+/-

Drawing Revisions

Drawn By	Date	Change
▲ RMB	2/27/2024	Revised scaling & Qty reduced
▲		
▲		
▲		
▲		
▲		
▲		
▲		
▲		

- Approved, as is
- Approved, w/ changes
- Requires New Layout
- Rejected

Authorized Signature of Approval _____

Title _____

Date Signed _____

Electrical
 *SIGN MEETS NEC 600 ELECTRICAL REQUIREMENTS.
 20 amp weatherproof electrical disconnect required for every 16 amps of signage. Actual number of circuits to be determined by a licensed electrical contractor.
 Actual location of box may vary.
 Input voltage - 120V.
 All signage will be (U.L.) 485TD compliant.

