

PLOT DATE: 8/21/2013 4:59:22 PM USER: DANIEL.MCCORMACK FILENAME: G:\clients\cambridge\MA20111401-A - Huron B2 & Drawings\Conformed Set\Production\_Drawings\Construction\_Saville Street.dwg

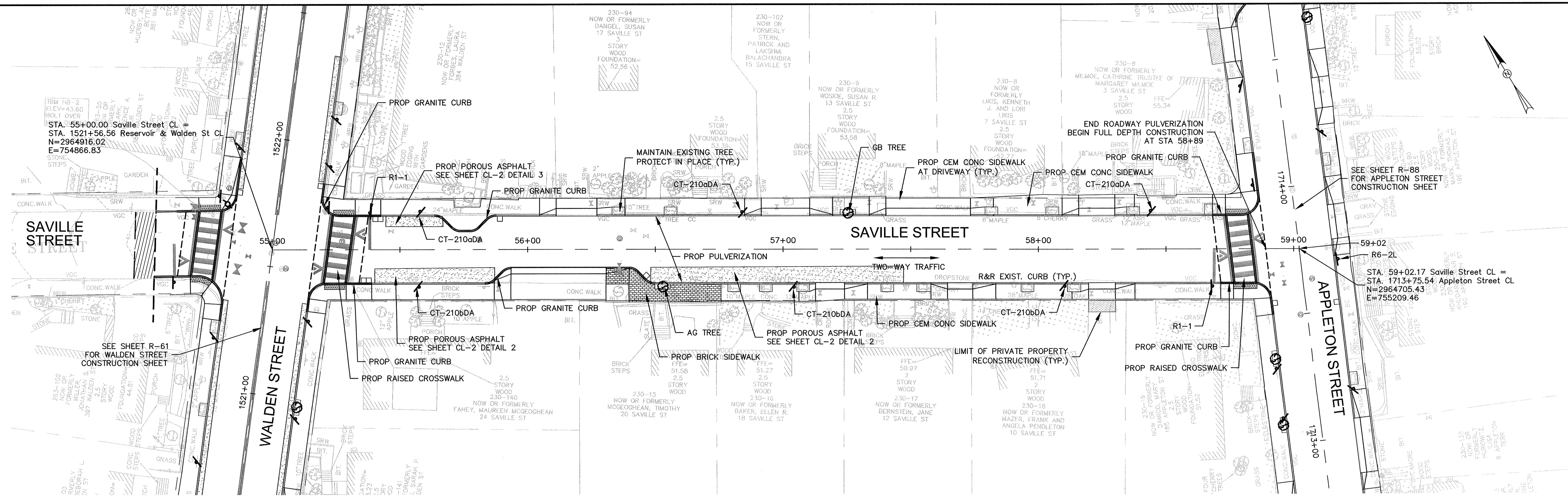

- NOTES:**
1. WORK IN SAVILLE STREET SHALL MEET THE REQUIREMENTS OF THE CITY OF CAMBRIDGE DEPARTMENT OF PUBLIC WORKS.
  2. SEE DETAILS ON SHEETS RG-1, RG-2 AND RG-3 FOR CURB INSTALLATION, PEDESTRIAN RAMP, DRIVEWAY, AND SIDEWALK CONSTRUCTION DETAILS.
  3. CONTRACTOR SHALL ADJUST EXISTING UTILITY COVERS AND CASTINGS TO RE-GRADED SURFACES. THE CONTRACTOR TO COORDINATE WITH RESPECTIVE UTILITY COMPANIES FOR GAS/TELECOM/CABLE/ELECTRIC.
  4. ALL VERTICAL GRANITE CURBING WITHIN WORK LIMITS SHALL BE REMOVED AND RESET UNLESS OTHERWISE NOTED.
  5. CONTRACTOR TO ADJUST TREE PIT OPENINGS AS NECESSARY TO MAINTAIN A MINIMUM AREA OF 12 SF. FOR EXISTING TREES, A MINIMUM OF 3'-0" WIDE SIDEWALK SHALL BE MAINTAINED BETWEEN TREE PIT AND BACK OF SIDEWALK UNLESS SHOWN OTHERWISE. EXISTING TREE PITS THAT ARE LESS THAN 5 FEET IN LENGTH (PARALLEL TO CURB) SHALL BE ADJUSTED TO A MINIMUM LENGTH OF 5'-0".
  6. PROPOSED TREE TYPE CODING AND LOCATIONS HAVE BEEN IDENTIFIED ON THE ROADWAY CONSTRUCTION SHEETS. REFER TO SHEET CL-1 FOR PLANTING LIST.
  7. ALL EXISTING FEATURES AT BACK OF SIDEWALK SHALL REMAIN IN PLACE UNLESS OTHERWISE NOTED. DAMAGES OR DISLODGING OF FEATURES AT BACK OF SIDEWALK SHALL BE REPAIRED/REPLACED AT NO ADDITIONAL COST TO THE OWNER.
  8. CONTRACTOR SHALL MATCH THE EXISTING GRADE AT THE LIMIT OF PROPOSED COLD PLANE AND OVERLAY. THE JOINT BETWEEN EXISTING AND PROPOSED PAVEMENT SHALL BE TREATED WITH INFRARED PAVEMENT SEALANT AND HOT POURED RUBBERIZED ASPHALT SEALER.
  9. ALL EXISTING TREES AND SHRUBS SHALL BE RETAINED UNLESS OTHERWISE NOTED.
  10. ALL EXISTING SIGNS AND POSTS SHALL BE REMOVED AND STACKED.
  11. ALL PROPOSED SIGNS SHALL BE LOCATED A LATERAL CLEARANCE OF 1' FROM CURB.
  12. PASSING ZONES HAVE BEEN LOCATED APPROXIMATELY EVERY 200' WITHIN ACCESSIBLE ROUTES. PASSING ZONES SHALL BE A MINIMUM SIZE OF 5'X5' AND HAVE A MAXIMUM SLOPE OF 1.5% IN ALL DIRECTIONS. FOR ACCESSIBLE ROUTES, REFER TO CONSTRUCTION DRAWINGS.

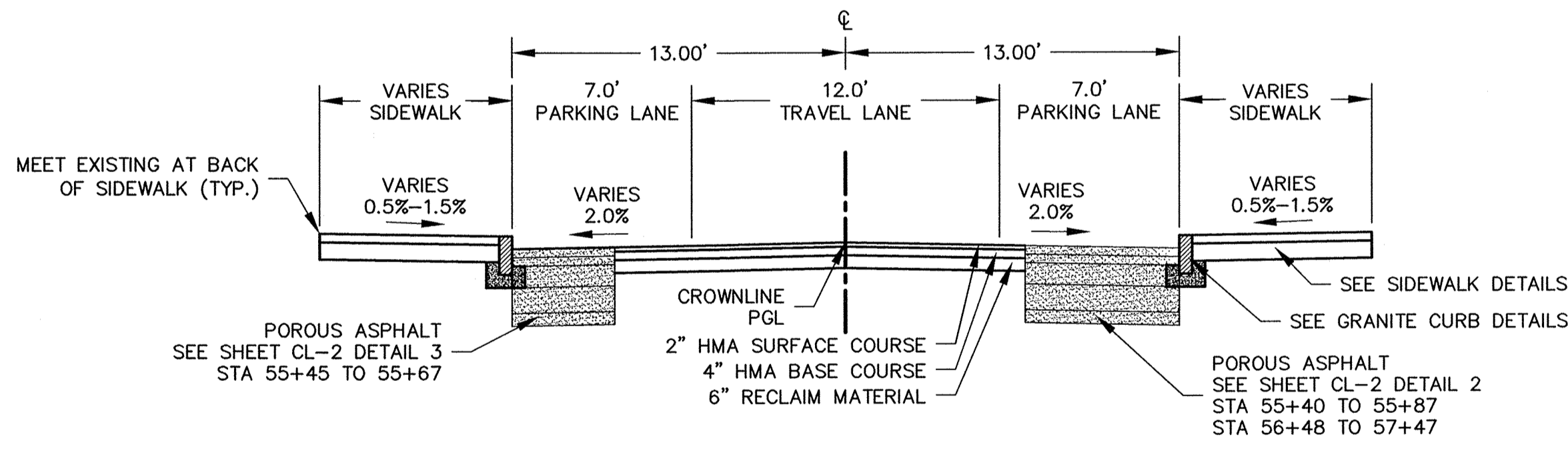

**TYPICAL SECTION**  
SAVILLE STREET  
STA 55+17 TO 58+59  
SCALE: 1"=5'

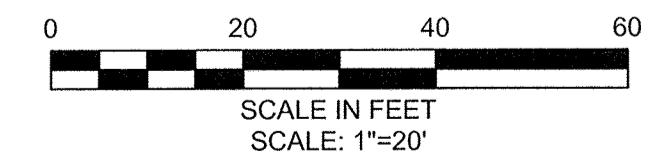

CONFORMED

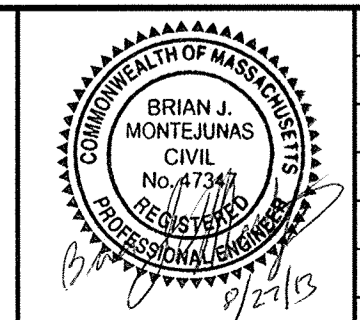

Scale	AS NOTED			
Date	AUGUST 2013			
Job No.	20110140.01-A			
Designed by	JB/TAL/KJL			
Drawn by	KJL			
Checked by	CMC/BJM	No.	Description	Date
Approved by	BJM		REVISIONS	



Client	CITY OF CAMBRIDGE, MASSACHUSETTS	Sheet	R-77
Project	HURON B SEWER SEPARATION PROJECT Contract No. 8B	File No.	6089
Drawing	ROADWAY - CONSTRUCTION PLAN SAVILLE STREET STA. 55+00 TO 59+02		