



CAMBRIDGE HISTORICAL COMMISSION

831 Massachusetts Avenue, 2nd Fl., Cambridge, Massachusetts 02139
Telephone: 617 349 4683 TTY: 617 349 6112
E-mail: histcomm@cambridgema.gov URL: www.cambridgema.gov/Historic

APPLICATION FOR CERTIFICATE

1. The undersigned hereby applies to the Cambridge Historical Commission for a Certificate of (check one box): Appropriateness, Nonapplicability, or Hardship, in accordance with Chapter 40C of the Massachusetts General Laws and/or Chapter 2.78 of the Municipal Code.

2. Address of property: , Cambridge, Massachusetts

3. Describe the proposed alteration(s), construction or demolition in the space provided below: (An additional page can be attached, if necessary).

Spyce, a restaurant company, plans to put a small pergola over our outdoor patio (about 20 seats outside of COVID). We would like to hang string lights and plan to have some plants outside. The design intent will match aspects of the building and the structure will be simple and made of wood. We believe a simple pergola with some string lights will liven up that corner of the square.

See attached pdf for some digital renderings of the proposed pergola.

I certify that the information contained herein is true and accurate to the best of my knowledge and belief. The undersigned also attests that he/she has read the statements printed on the reverse.

Name of Property Owner of Record: <input type="text" value="Piedmont - One Brattle Square I, LLC"/>	
Mailing Address: <input type="text" value="c/o Piedmont Office REIT, One Brattle Square, Cambridge, MA 02138"/>	
Telephone/Fax: <input type="text" value="617.661.0903"/>	E-mail: <input type="text" value="steve.brodsky@piedmontreit.com"/>
Signature of Property Owner of Record: <u><i>Steve Brodsky - General Manager</i></u> (Required field; application will not be considered complete without property owner's signature)	
Name of proponent, if not record owner: <input type="text" value="SPYCE FOOD CO PERMIT AGENT-DANIEL BRENNAN"/>	
Mailing Address: <input type="text" value="8 STONEGATE LANE SALEM NH 03079"/>	
Telephone/Fax: <input type="text" value="603-505-5633"/>	E-mail: <input type="text" value="DPBPERMITS@GMAIL.COM"/>

<u>(for office use only):</u>			
Date Application Received: <u>8/13/20</u>	Case Number: <u>4384</u>	Hearing Date: <u>9/10/2020</u>	
Type of Certificate Issued: _____	Date Issued: _____		

NOTE: INSTALLATION TO FOLLOW MANUFACTURES AND LOCAL CODE STANDARDS. DRAWINGS NOT FOR CONSTRUCTION

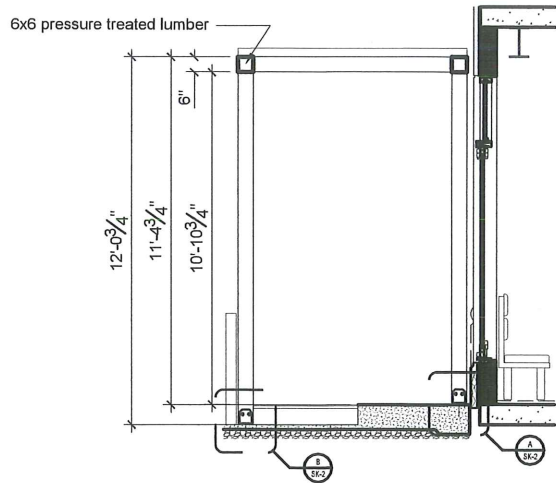

D PATIO SECTION
SCALE: 1/4" = 1'-0"

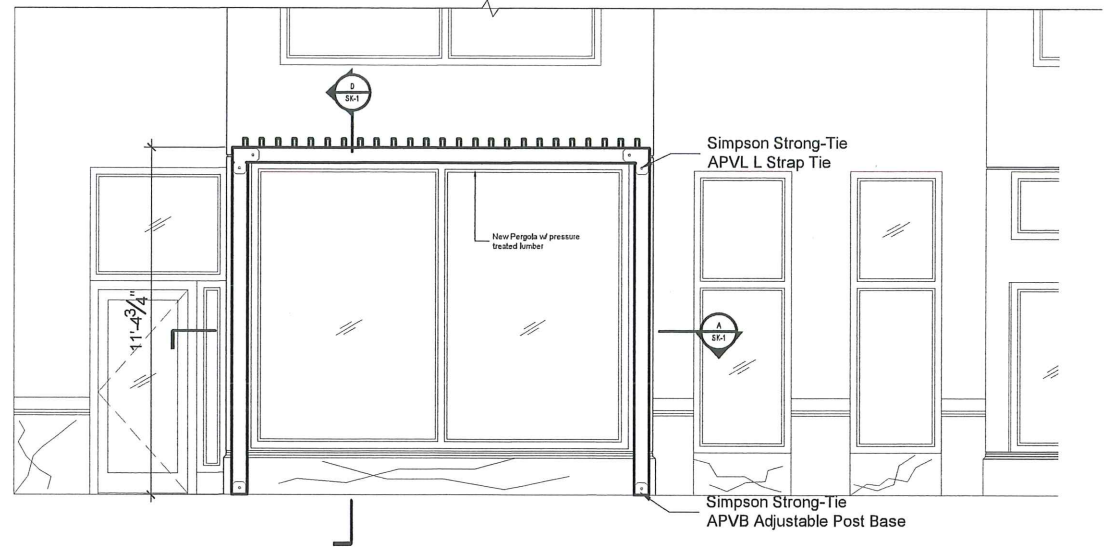

C PATIO ELEVATION
SCALE: 1/4" = 1'-0"

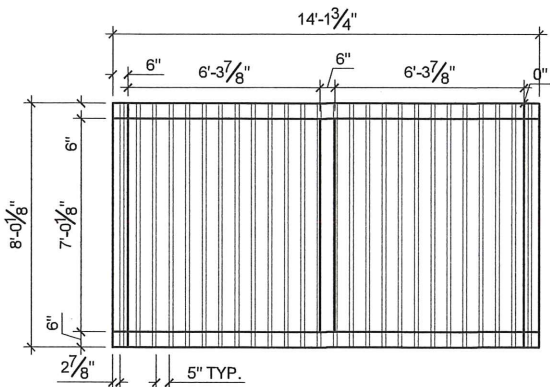

B PERGOLA PLAN
SCALE: 1/4" = 1'-0"

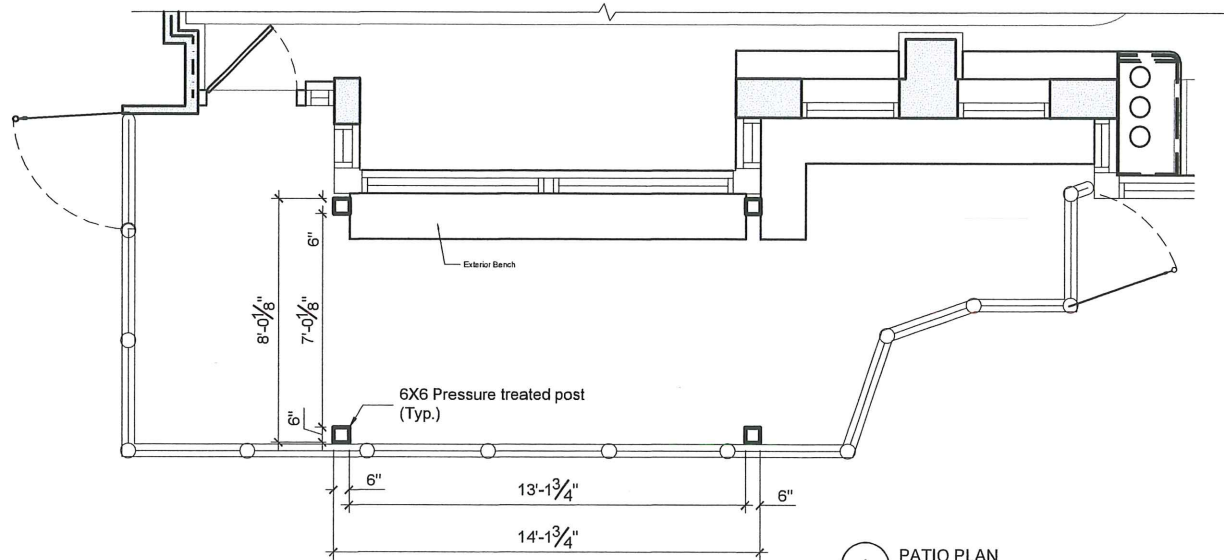

A PATIO PLAN
SCALE: 1/4" = 1'-0"

SK-01
SPYCE HARVARD SQ - PERGOLA
SCALE AS NOTED

CEDAR STREET

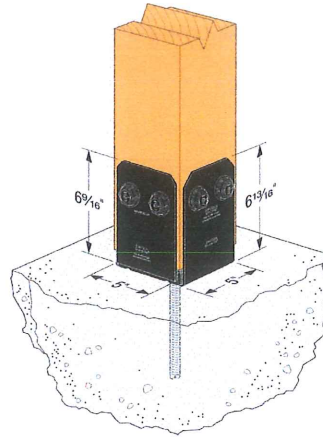

TYPICAL SIMPSON STRONGTIE -
APVB66 INSTALLATION - OUTDOOR ACCENTS AVANT COLLECTION

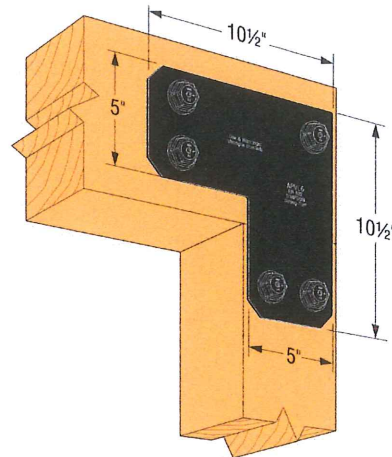
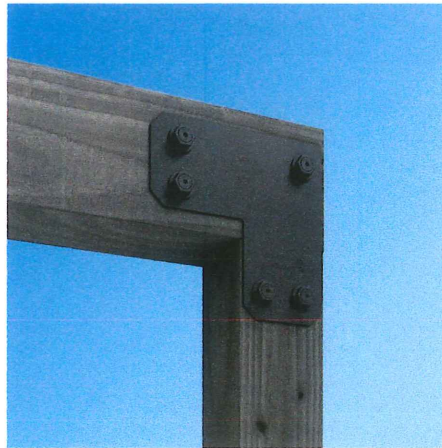

TYPICAL SIMPSON STRONGTIE -
APVL6 INSTALLATION - OUTDOOR ACCENTS AVANT COLLECTION

NOTE: INSTALLATION TO FOLLOW MANUFACTURES AND LOCAL CODE STANDARDS. DRAWINGS NOT FOR CONSTRUCTION

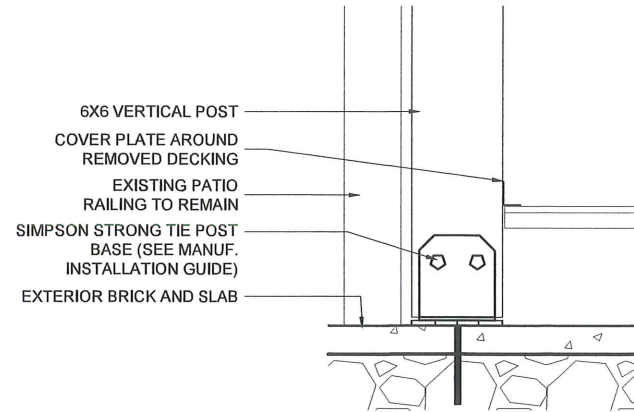

B POST DETAIL
SCALE: 1 1/2" = 1'-0"

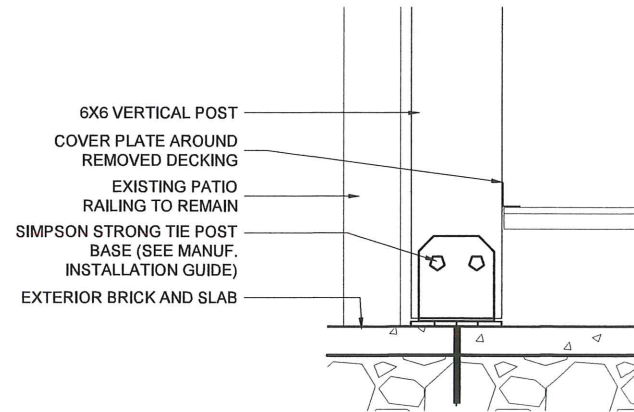

A POST DETAIL
SCALE: 1 1/2" = 1'-0"

SK-02
SPYCE HARVARD SQ - PERGOLA
SCALE AS NOTED

CEDAR STREET

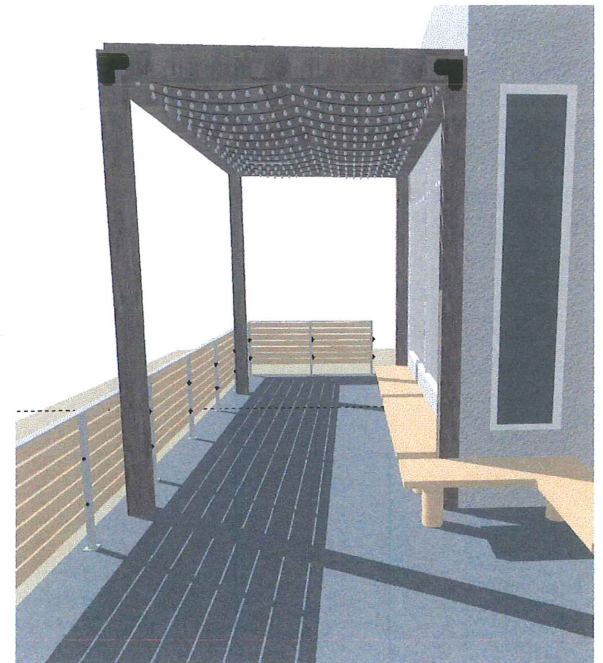
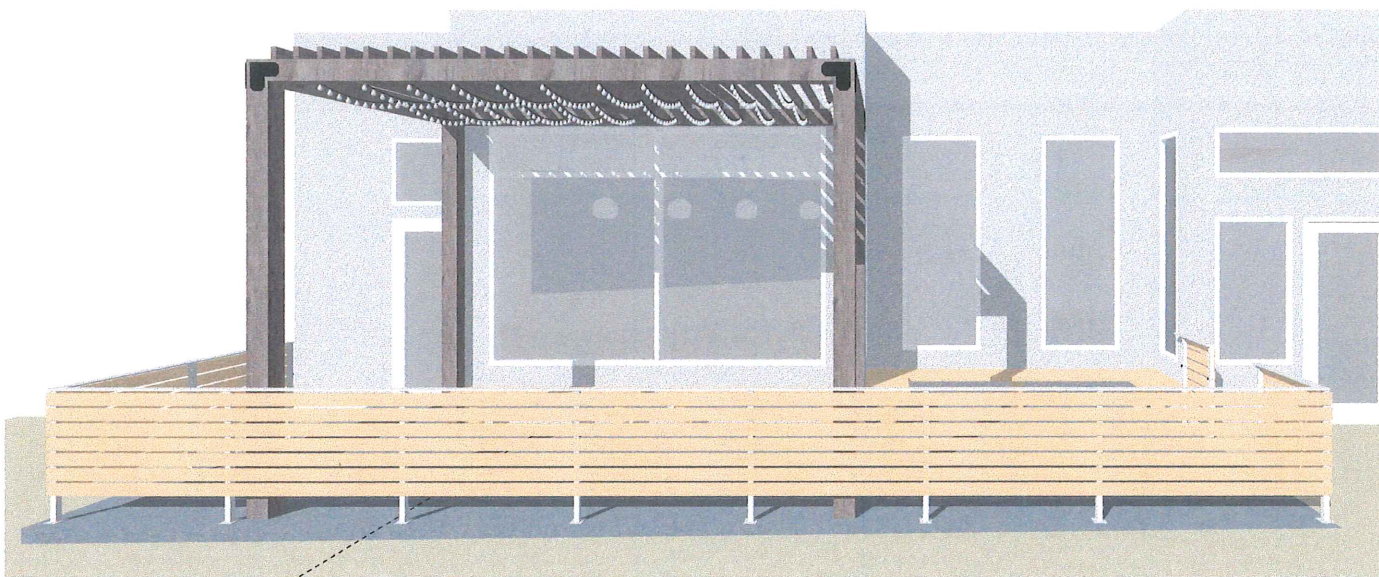

SK-03

SPYCE HARVARD SQ - PERGOLA
NTS

CEDAR STREET

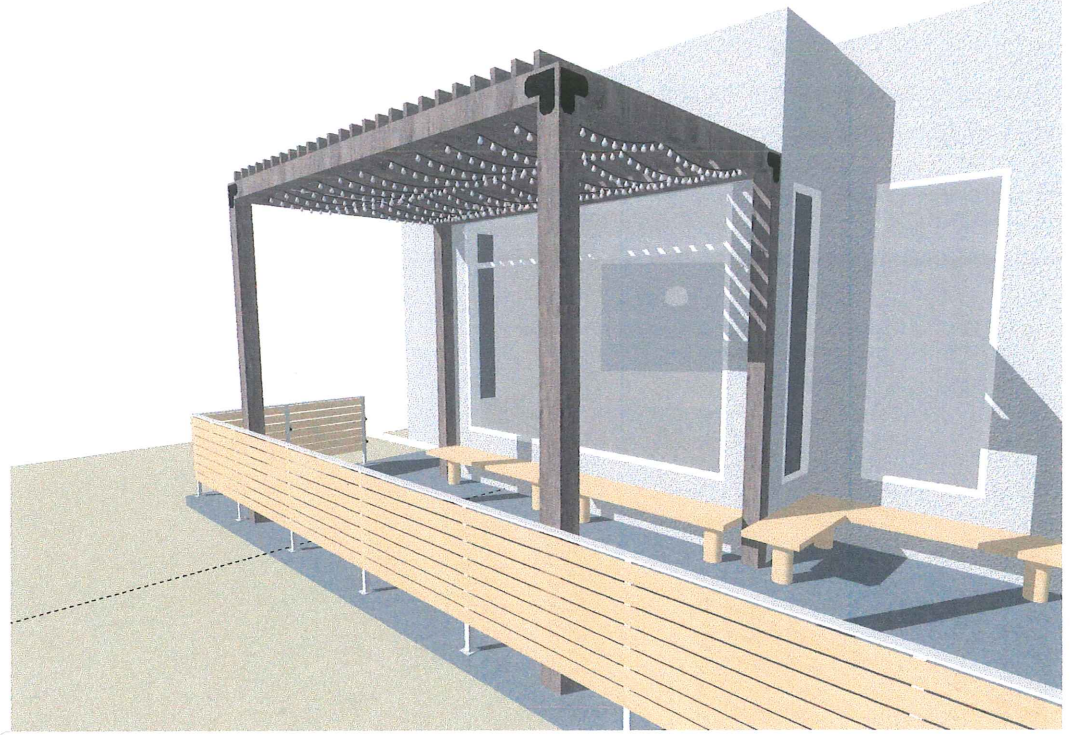
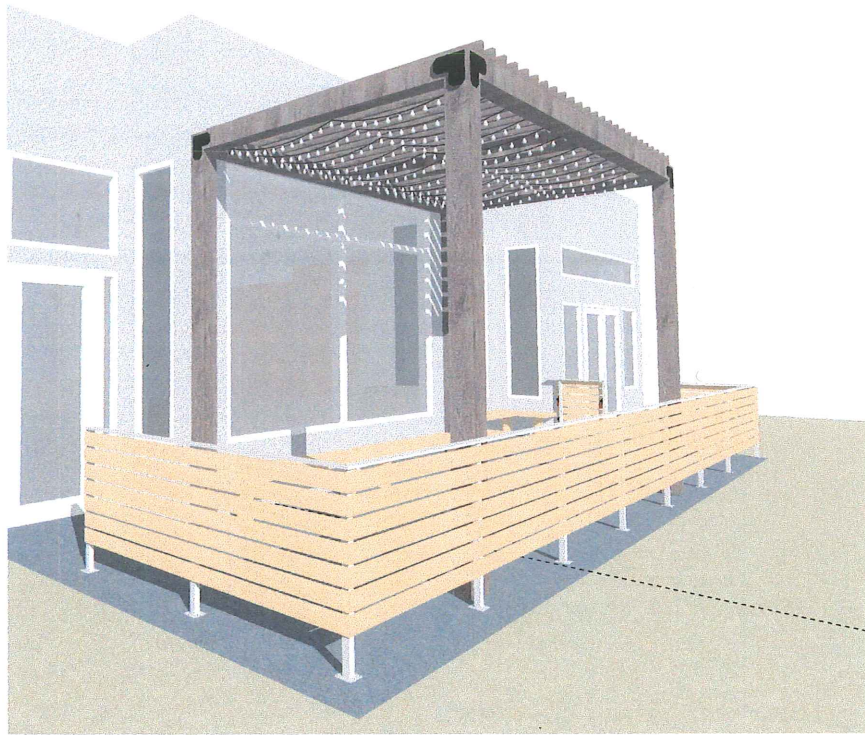

SK-04
SPYCE HARVARD SQ - PERGOLA
NTS

CEDAR STREET

Railing Detail

Wood slat assembly to be fastened to existing structure of fence/railing

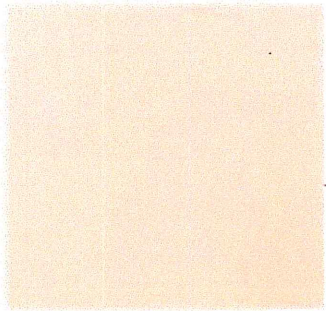
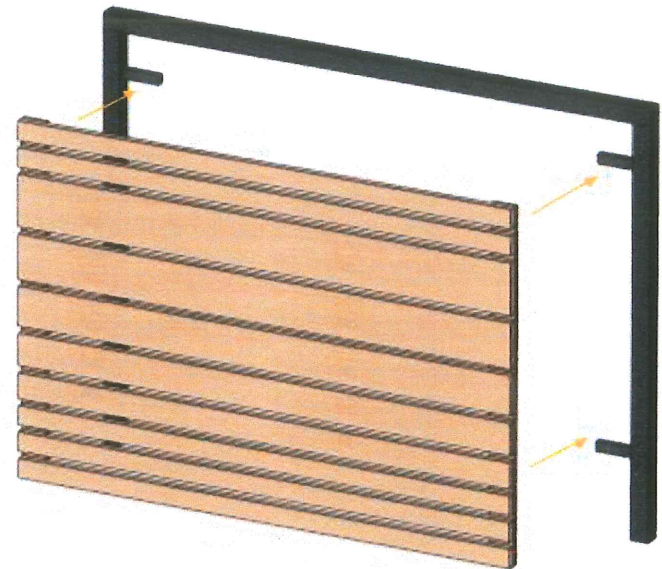
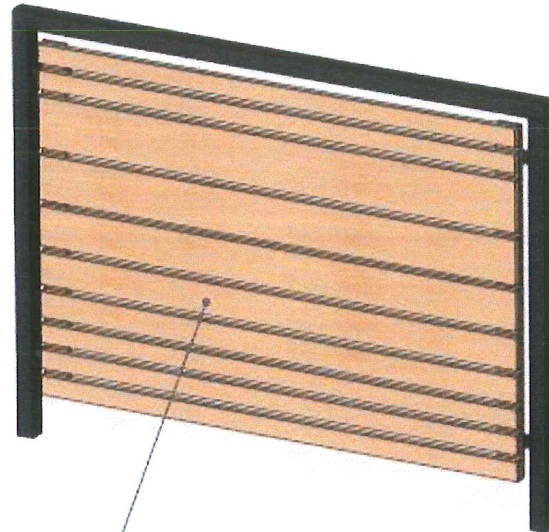

Pressure Treated Birch
Plywood w/ Outdoor
Wood Sealer