



# CITY OF CAMBRIDGE

BOARD OF ZONING APPEAL

831 Massachusetts Avenue, Cambridge MA 02139

617-349-6100

2021 JUL 20 PM 12: 20

OFFICE OF THE CITY CLERK  
CAMBRIDGE, MASSACHUSETTS

## BZA Application Form

**BZA Number: 102207**

### General Information

The undersigned hereby petitions the Board of Zoning Appeal for the following:

Special Permit:   X                        Variance:                             Appeal:       

**PETITIONER:** 1925 Mass Ave LLC C/O Eric Hoagland

**PETITIONER'S ADDRESS:** 195 Lexington Avenue, Cambridge, MA 02138

**LOCATION OF PROPERTY:** 1923 Massachusetts Ave., Cambridge, MA

**TYPE OF OCCUPANCY:** Wireless Telecommunications Facility    **ZONING DISTRICT:** Business C Zone

### **REASON FOR PETITION:**

/Telecommunication Facility (antenna)/

### **DESCRIPTION OF PETITIONER'S PROPOSAL:**

Modification to the existing T-Mobile wireless telecommunications facility involving replace 8 existing antennas, adding 4 additional antennas, replacing 4 existing RRHs, and adding 4 additional RRHs within the existing lease area.

### **SECTIONS OF ZONING ORDINANCE CITED:**

- Article: 4.000      Section: 4.32.G.1 (Telecommunication Facility).
- Article: 4.000      Section: 4.40 (Footnote 49) (Telecommunication Facility).
- Article: 10.000    Section: 10.40-10.46 (Special Permit).

6409A

Original  
Signature(s):

Eric W. Hoagland  
(Petitioner (s)/ Owner)

Hoagland, Eric  
(Print Name)

Address:

Tel. No.                      857-998-0836  
E-Mail Address:          ehoagie@gmail.com

**BZA Application Form**

**SUPPORTING STATEMENT FOR A SPECIAL PERMIT**

**Please describe in complete detail how you meet each of the following criteria referring to the property and proposed changes or uses which are requested in your application. Attach sheets with additional information for special permits which have additional criteria, e.g.; fast food permits, comprehensive permits, etc., which must be met.**

**Granting the Special Permit requested for 1923 Massachusetts Ave , Cambridge, MA (location) would not be a detriment to the public interest because:**

**A) Requirements of the Ordinance can or will be met for the following reasons:**

The proposed modification of the existing facility will have minimal visual impact compared to the existing configuration and provide an improved wireless communication system to those in the effected area.

**B) Traffic generated or patterns of access or egress would not cause congestion hazard, or substantial change in established neighborhood character for the following reasons:**

No physical modification of the building or parking area will be modified and no traffic patterns will be changed due to the change to the roof top cell site.

**C) The continued operation of or the development of adjacent uses as permitted in the Zoning Ordinance would not be adversely affected by the nature of the proposed use for the following reasons:**

The proposed work will result in minimal visual impact and will not impair the use of property in the immediate vicinity.

**D) Nuisance or hazard would not be created to the detriment of the health, safety, and/or welfare of the occupant of the proposed use or the citizens of the City for the following reasons:**

This is a modification and improvement to an existing wireless facility which conforms to FCC regulations and standards.

**E) For other reasons, the proposed use would not impair the integrity of the district or adjoining district or otherwise derogate from the intent or purpose of this ordinance for the following reasons:**

The approval of this modification will lead to improved data and voice communication services within the effective range with minimal visual impact.

**\*If you have any questions as to whether you can establish all of the applicable legal requirements, you should consult with an attorney.**

**BZA Application Form****DIMENSIONAL INFORMATION****Applicant:** 1925 Mass Ave LLC**Location:** 195 Lexington Avenue**Phone:** 857-998-0836**Present Use/Occupancy:** Wireless  
Telecommunications Facility**Zone:** Business C Zone**Requested Use/Occupancy:** Wireless  
Telecommunications Facility

	<b><u>Existing Conditions</u></b>	<b><u>Requested Conditions</u></b>	<b><u>Ordinance Requirements</u></b>	
<b><u>TOTAL GROSS FLOOR AREA:</u></b>	N/A	N/A	N/A	(max.)
<b><u>LOT AREA:</u></b>	N/A	N/A	N/A	(min.)
<b><u>RATIO OF GROSS FLOOR AREA TO LOT AREA: <sup>2</sup></u></b>	N/A	N/A	N/A	
<b><u>LOT AREA OF EACH DWELLING UNIT</u></b>	N/A	N/A	N/A	
<b><u>SIZE OF LOT:</u></b>				
WIDTH	N/A	N/A	N/A	
DEPTH	N/A	N/A	N/A	
<b><u>SETBACKS IN FEET:</u></b>				
FRONT	N/A	N/A	N/A	
REAR	N/A	N/A	N/A	
LEFT SIDE	N/A	N/A	N/A	
RIGHT SIDE	N/A	N/A	N/A	
<b><u>SIZE OF BUILDING:</u></b>				
HEIGHT	N/A	N/A	N/A	
WIDTH	N/A	N/A	N/A	
<b><u>RATIO OF USABLE OPEN SPACE TO LOT AREA:</u></b>	N/A	N/A	N/A	
<b><u>NO. OF DWELLING UNITS:</u></b>	N/A	N/A	N/A	
<b><u>NO. OF PARKING SPACES:</u></b>	N/A	N/A	N/A	
<b><u>NO. OF LOADING AREAS:</u></b>	N/A	N/A	N/A	
<b><u>DISTANCE TO NEAREST BLDG. ON SAME LOT</u></b>	N/A	N/A	N/A	

Describe where applicable, other occupancies on the same lot, the size of adjacent buildings on same lot, and type of construction proposed, e.g; wood frame, concrete, brick, steel, etc.

1. SEE CAMBRIDGE ZONING ORDINANCE ARTICLE 5.000, SECTION 5.30 (DISTRICT OF DIMENSIONAL REGULATIONS).
2. TOTAL GROSS FLOOR AREA (INCLUDING BASEMENT 7'-0" IN HEIGHT AND ATTIC AREAS GREATER THAN 5') DIVIDED BY LOT AREA.
3. OPEN SPACE SHALL NOT INCLUDE PARKING AREAS, WALKWAYS OR DRIVEWAYS AND SHALL HAVE A MINIMUM DIMENSION OF 15'.

## Pacheco, Maria

---

**From:** Ratay, Olivia  
**Sent:** Thursday, August 19, 2021 2:33 PM  
**To:** Pacheco, Maria  
**Subject:** FW: Cambridge Board of Zoning Appeal (BZA): 8/19/21 Hearing Instructions

**From:** jshappy@transcendwireless.com <jshappy@transcendwireless.com>  
**Sent:** Thursday, August 19, 2021 2:25 PM  
**To:** Daglian, Sisia <sdaglian@cambridgema.gov>  
**Cc:** Ratay, Olivia <oratay@cambridgema.gov>; 'Eric Hoagland' <ehoagie@gmail.com>  
**Subject:** RE: Cambridge Board of Zoning Appeal (BZA): 8/19/21 Hearing Instructions

Sisia,

After speaking internally with T-Mobile, as well as discussing with the building owner, T-Mobile would like to ask for a continuance on tonight's meeting in order to address the concerns the Planning Board brought up on Tuesday and sent to me yesterday afternoon. Is this something that will need to be done during the BZA meeting tonight or can this be confirmed in advance?

Jake Shappy  
10 Industrial Ave, Suite 3  
Mahwah, NJ 07430  
Cell: 845-553-3330  
[jshappy@transcendwireless.com](mailto:jshappy@transcendwireless.com)

**From:** Daglian, Sisia <sdaglian@cambridgema.gov>  
**Sent:** Wednesday, August 18, 2021 11:47 AM  
**To:** 'jshappy@transcendwireless.com' <[jshappy@transcendwireless.com](mailto:jshappy@transcendwireless.com)>  
**Cc:** Ratay, Olivia <[oratay@cambridgema.gov](mailto:oratay@cambridgema.gov)>; 'Eric Hoagland' <[ehoagie@gmail.com](mailto:ehoagie@gmail.com)>  
**Subject:** RE: Cambridge Board of Zoning Appeal (BZA): 8/19/21 Hearing Instructions

BZA is only on Thursdays.

Regards,

Sisia Daglian  
Inspectional Services  
617-349-6107

**From:** [jshappy@transcendwireless.com](mailto:jshappy@transcendwireless.com) <[jshappy@transcendwireless.com](mailto:jshappy@transcendwireless.com)>  
**Sent:** Tuesday, August 17, 2021 6:49 PM  
**To:** Daglian, Sisia <[sdaglian@cambridgema.gov](mailto:sdaglian@cambridgema.gov)>  
**Cc:** Ratay, Olivia <[oratay@cambridgema.gov](mailto:oratay@cambridgema.gov)>; 'Eric Hoagland' <[ehoagie@gmail.com](mailto:ehoagie@gmail.com)>  
**Subject:** RE: Cambridge Board of Zoning Appeal (BZA): 8/19/21 Hearing Instructions

Sisia,



# City of Cambridge

MASSACHUSETTS

BOARD OF ZONING APPEAL

831 Mass Avenue, Cambridge, MA.  
(617) 349-6100

2021 AUG 20 AM 10:05

OFFICE OF THE CITY CLERK  
CAMBRIDGE, MASSACHUSETTS

## Board of Zoning Appeal Waiver Form

**The Board of Zoning Appeal  
831 Mass Avenue  
Cambridge, MA 02139**

RE: Case # BZA-102207

Address: 1923 Mass Ave

Owner,  Petitioner, or  Representative: Jake Shappy  
(Print Name)

**hereby waives the required time limits for holding a public hearing as required by Section 9 or Section 15 of the Zoning Act of the Commonwealth of Massachusetts, Massachusetts General Laws, Chapter 40A. The  Owner,  Petitioner, or  Representative further hereby waives the Petitioner's and/or Owner's right to a Decision by the Board of Zoning Appeal on the above referenced case within the time period as required by Section 9 or Section 15 of the Zoning Act of the Commonwealth of Massachusetts, Massachusetts General Laws, Chapter 40A, and/or Section 6409 of the federal Middle Class Tax Relief and Job Creation Act of 2012, codified as 47 U.S.C. §1455(a), or any other relevant state or federal regulation or law.**

Date: 8/19/21

Signature [Signature]

1 \* \* \* \* \*

2 (8:00 p.m.)

3 Sitting Members: Brendan Sullivan, Jim Monteverde, Laura  
4 Wernick, Matina Williams and Jason  
5 Marshall

6 BRENDAN SULLIVAN: It is now 8:00. The Board will  
7 hear Case Number #102207 -- 1923 Massachusetts Avenue.

8 Anybody representing the applicant at this time?

9 [Pause]

10 BRENDAN SULLIVAN: No. We have a letter in the  
11 file. "After speaking internally with T-Mobile, as well as  
12 discussing with the building owner, T-Mobile would like to  
13 ask for a continuance on tonight's meeting, in order to  
14 address the concerns the Planning Board brought up on  
15 Tuesday and sent yesterday afternoon."

16 And they want to know if they can be done just  
17 tonight or can it be confirmed in advance, and it was  
18 confirmed in advance that they could be granted the  
19 continuance.

20 The Planning Board recommends that the BZA  
21 continue the hearing also, to allow the applicant to revise  
22 the proposal to respond to the comments and suggestions

1 provided in the CDD memo, which is two pages long. I won't  
2 need to go into that. That is a part of the public record,  
3 and available for Board members and the public to review.

4 On the motion to continue Case Number #102207 --  
5 1923 Massachusetts Avenue, the motion is to continue it to  
6 October 21, 2021, at 6:00 p.m. on the condition that the  
7 petitioner change the posting sign to reflect the new date  
8 of October 21 and the new time of 6:00 p.m.

9 Also, that the petitioner sign a waiver to the  
10 statutory requirement for a hearing and a decision to be  
11 rendered thereof, and that should any new submittals, which  
12 there will be, must be in the file no later than Monday  
13 prior to the October 21 meeting.

14 Also, that the petitioner -- and it's imperative  
15 that the petitioner also submit any new submissions,  
16 documents to the Planning Board for their review and perusal  
17 and comment back to the Board prior to our October 21  
18 hearing.

19 On the motion to continue this matter, Jim  
20 Monteverde?

21 JIM MONTEVERDE: Jim Monteverde in favor of the  
22 continuance.

1 BRENDAN SULLIVAN: Matina?

2 MATINA WILLIAMS: Matina Williams in favor of the  
3 continuance.

4 BRENDAN SULLIVAN: Laura?

5 LAURA WERNICK: Laura Wernick in favor of the  
6 continuance.

7 BRENDAN SULLIVAN: Jason?

8 JASON MARSHALL: Jason Marshall yes in favor of  
9 the continuance.

10 BRENDAN SULLIVAN: And the Chair votes also in  
11 favor of the continuance.

12 [All vote YES]

13 The matter is continued until October 2021.

14 And that concludes our meeting. Thank you  
15 very much, Board members.

16 COLLECTIVE: Thank you very much. Goodnight.  
17 Bye.

18 BRENDAN SULLIVAN: Goodnight and stay well.

19 [8:02 p.m. End of Proceedings]

20

21

22





10 INDUSTRIAL AVE,  
SUITE 3  
MAHWAH NJ 07430

PHONE: 201.684.0055  
FAX: 201.684.0066

---

October 18, 2021

City of Cambridge  
831 Massachusetts Avenue  
Cambridge, MA 02139

RE: 1923-1925 Massachusetts Ave. Cambridge, MA (T-Mobile Site ID 4DE7032A) – BZA-102207

Maria Pacheco and Members of the Cambridge BZA,

I am asking for an extension regarding the T-Mobile filing to modify the existing wireless telecommunications facility located at 1923 Mass Ave. in Cambridge, MA. I have been working with T-Mobile's RF engineers as well as our A&E to revise the drawings and supporting documents for this project to match the recommendations provided to us by the Planning Board on August 17, 2021 to the best of our ability. To this end we are unable to provide completed revision at this time and request an extension so that all points that can be addressed are. Thank you for your understanding and assistance in this matter.

If you have any questions, please feel free to contact me.

Thank you,

Jake Shappy  
Authorized Agent of T-Mobile  
165 Orange Turnpike Sloatsburg, NY 10974  
845-553-3330 – JShappy@TranscendWireless.com

# T-Mobile®

## T-MOBILE NORTHEAST LLC ANCHOR

**SITE #: 4DE7032A**  
**SITE NAME: B0032/1923-1925 MASS. AVE.**  
**1923-1925 MASSACHUSETTS AVE.**  
**CAMBRIDGE, MA 02140**  
**MIDDLESEX COUNTY**

**CONSTRUCTION DRAWINGS**  
 ALL SCALES RELATIVE TO 24"X36" PAGE SIZE

**APPROVED**  
 By Ryan Monte de Ramos at 8:40 pm, Aug 28, 2020

**COM-EX**  
 Consultants  
 115 ROUTE 46  
 SUITE E39  
 MOUNTAIN LAKES, NJ 07046  
 PHONE: 862.209.4300  
 FAX: 862.209.4301

**T-Mobile®**  
 T-MOBILE NORTHEAST LLC  
 15 COMMERCE WAY, SUITE B  
 NORTON, MA 02766  
 OFFICE: (508) 286-2700  
 FAX: (508) 286-2893

Documents prepared by Com-Ex Consultants, including this document, are to be used only for the specific project and specific use for which they were intended. Any extension of use to any other projects, by owner or by any other party, without the expressed written consent of Com-Ex Consultants, is done unlawfully and at the users own risk. If used in a way other than that specifically intended, user will hold Com-Ex Consultants, harmless from all claims and losses.

**SITE CONFIGURATION: 4SEC-67D5997DB OUTDOOR**

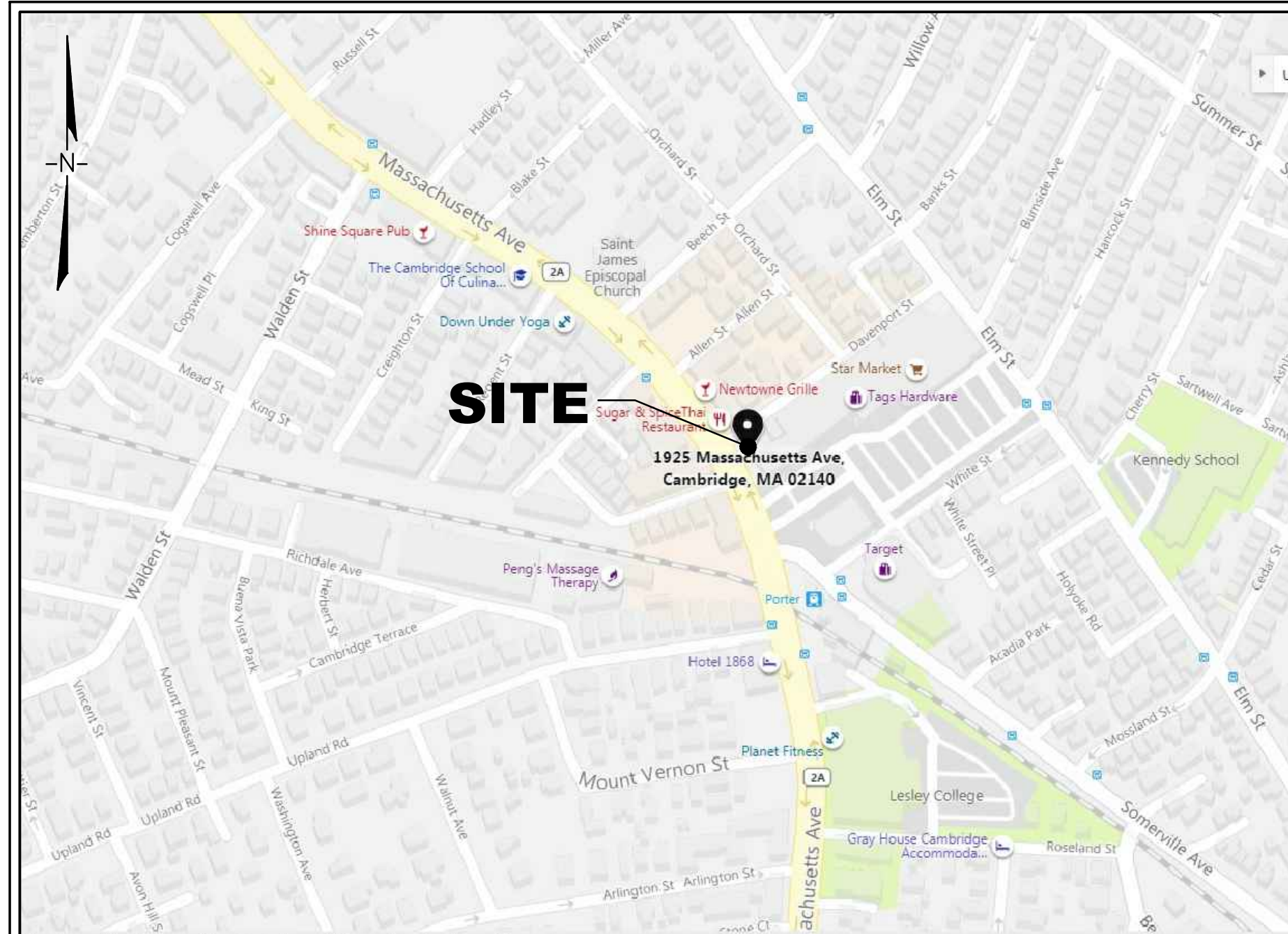

**KEY MAP**

SCALE = N.T.S.

**SITE LOCATION INFORMATION**

SITE NUMBER: 4DE7032A  
 SITE ADDRESS: 1923-1925 MASSACHUSETTS AVE. CAMBRIDGE, MA 02140  
 JURISDICTION: CITY OF CAMBRIDGE  
 COUNTY: BRISTOL COUNTY  
 PARCEL ID: 179 81  
 PROPERTY OWNER: 1925 MASS AVE LLC  
 195 LEXINGTON AVE, 100  
 CAMBRIDGE, MA 02138  
 APPLICANT: T-MOBILE NORTHEAST LLC  
 15 COMMERCE WAY, SUITE B  
 NORTON, MA 02766

**SITE CHARACTERISTICS**

LATITUDE: N 42.38949000  
 LONGITUDE: W -71.11966100  
 STRUCTURE TYPE: BUILDING  
 LOCATION OF PROPOSED EQUIPMENT: ROOFTOP  
 STRUCTURE HEIGHT: ±44'-0" AGL  
 ANTENNA (RAD CENTER) ALPHA - ±49'-0" AGL  
 BETA - ±45'-0" AGL  
 GAMMA - ±53'-0" AGL  
 DELTA - ±45'-0" AGL

**SHEET INDEX**

SHEET NO.	SHEET DESCRIPTION
T-1	TITLE SHEET
GN-1	GROUNDING & GENERAL NOTES
A-1	ROOF PLAN & ELEVATION
A-2	ANTENNA PLANS
A-3	FINAL EQUIPMENT PLAN & SCHEMATIC
A-4	DETAILS
E-1	ELECTRICAL DETAILS & NOTES

**UNDERGROUND SERVICE ALERT**



**GENERAL NOTES**

THIS DOCUMENT IS THE CREATION, DESIGN, PROPERTY, AND COPYRIGHTED WORK OF T-MOBILE. ANY DUPLICATION OR USE WITHOUT EXPRESS WRITTEN CONSENT IS STRICTLY PROHIBITED. DUPLICATION AND USE BY GOVERNMENT AGENCIES FOR THE PURPOSES OF CONDUCTING THEIR LAWFULLY AUTHORIZED REGULATORY AND ADMINISTRATIVE FUNCTIONS IS SPECIFICALLY ALLOWED.

THE FACILITY IS AN UNMANNED, PRIVATE, AND SECURED EQUIPMENT INSTALLATION. IT IS ONLY ACCESSED BY TRAINED TECHNICIANS FOR PERIODIC ROUTINE MAINTENANCE AND, THEREFORE, DOES NOT REQUIRE ANY WATER OR SANITARY SEWER SERVICE. THE FACILITY IS NOT GOVERNED BY REGULATIONS REQUIRING PUBLIC ACCESS PER ADA REQUIREMENTS.

CONTRACTOR SHALL VERIFY ALL PLANS AND EXISTING DIMENSIONS AND CONDITIONS ON THE JOB SITE AND SHALL IMMEDIATELY NOTIFY THE T-MOBILE NORTHEAST, LLC REPRESENTATIVE IN WRITING OF DISCREPANCIES BEFORE PROCEEDING WITH THE WORK OR BE RESPONSIBLE FOR SAME.

**SPECIAL STRUCTURAL NOTES**

STRUCTURE OWNER SHALL BE RESPONSIBLE FOR GLOBAL STRUCTURAL STABILITY ANALYSIS OF EXISTING SUPPORT STRUCTURE. GENERAL CONTRACTOR SCOPE OF WORK SHALL INCLUDE ALL REQUIRED STRUCTURAL MODIFICATIONS, RE-BUNDLING OF COAXIAL CABLES OR OTHER SPECIAL MODIFICATIONS AS OUTLINED THEREIN.

STRUCTURAL DESIGNS AND DETAILS FOR ANTENNA MOUNTS COMPLETED BY COM-EX CONSULTANTS, LLC ON BEHALF OF T-MOBILE ARE INCLUSIVE OF THE ENTIRE ANTENNA SUPPORT STRUCTURE (GLOBAL STRUCTURAL STABILITY ANALYSIS BY OTHERS), EXISTING PLATFORM, EXISTING ANTENNA MOUNTS, AND ALL OTHER ASPECTS OF THE STRUCTURE THAT WILL SUPPORT THE T-MOBILE EQUIPMENT DEPLOYMENT AS DEPICTED HEREIN.

COM-EX CONSULTANTS, LLC ASSUMES THAT THE STRUCTURE IS PROPERLY CONSTRUCTED AND MAINTAINED. ALL STRUCTURAL MEMBERS AND THEIR CONNECTIONS ARE ASSUMED TO BE IN GOOD CONDITION AND ARE FREE FROM DEFECTS WITH NOT DETERIORATION TO IT'S MEMBER CAPACITIES.

**APPROVALS**

PROJECT MANAGER	DATE
CONSTRUCTION	DATE
RF ENGINEERING	DATE
ZONING / SITE ACQUISITION	DATE
OPERATIONS	DATE

**SCHEDULE OF REVISIONS**

REV. NO.	DATE	DESCRIPTION OF CHANGES
7		
6		
5		
4		
3		
2	08/27/20	ISSUED AS FINAL
1	07/23/20	REVISED PER RF COMMENTS
0	06/30/20	INITIAL SUBMISSION

**DRAWN BY:** WG  
**CHECKED BY:** CJT  
**SCALE:** AS NOTED  
**JOB NO:** 20002-TRN

INFORMATION ON THIS SET OF DRAWINGS IS NOT FOR OFFICIAL USE UNLESS ACCOMPANIED BY THE STAMPED SEAL & SIGNATURE OF A PROFESSIONAL ENGINEER

**NICHOLAS D. BARILE**  
 PROFESSIONAL ENGINEER, MA LIC. No. 11464

**SITE #: 4DE7032A**  
**B0032/1923-1925 MASS AVE**  
**1923-1925 MASSACHUSETTS AVE.**  
**CAMBRIDGE, MA 02140**  
**MIDDLESEX COUNTY**

**DRAWING TITLE:**

**TITLE SHEET**

**DRAWING SHEET: 1 OF 7**

**T-1**

## GENERAL NOTES

- FOR THE PURPOSE OF THE CONSTRUCTION DRAWING, THE FOLLOWING DEFINITIONS SHALL APPLY:
  - CONTRACTORS – TO BE DETERMINED
  - SUBCONTRACTOR – GENERAL CONTRACTOR (CONSTRUCTION)
  - OWNER – T-MOBILE
- PRIOR TO THE SUBMISSION OF BIDS, THE BIDDING SUBCONTRACTOR SHALL VISIT THE CELL SITE TO FAMILIARIZE WITH THE EXISTING CONDITIONS AND TO CONFIRM THAT THE WORK CAN BE ACCOMPLISHED AS SHOWN ON THE CONSTRUCTION DRAWINGS. ANY DISCREPANCY FOUND SHALL BE BROUGHT TO THE ATTENTION OF THE CONTRACTOR.
- ALL MATERIALS FURNISHED AND INSTALLED SHALL BE IN STRICT ACCORDANCE WITH ALL APPLICABLE CODES, REGULATIONS AND ORDINANCES. SUBCONTRACTOR SHALL ISSUE ALL APPROPRIATE NOTICES AND COMPLY WITH ALL LAWS, ORDINANCES, RULES, REGULATIONS AND LAWFUL ORDERS OF ANY PUBLIC AUTHORITY REGARDING THE PERFORMANCE OF THE WORK. ALL WORK CARRIED OUT SHALL COMPLY WITH ALL APPLICABLE MUNICIPAL AND UTILITY COMPANY SPECIFICATIONS AND LOCAL JURISDICTIONAL CODES, ORDINANCES AND APPLICABLE REGULATIONS.
- DRAWINGS PROVIDED HERE ARE NOT TO BE SCALED AND ARE INTENDED TO SHOW OUTLINE ONLY.
- UNLESS NOTED OTHERWISE, THE WORK SHALL INCLUDE FURNISHING MATERIALS, EQUIPMENT APPURTENANCES, AND LABOR NECESSARY TO COMPLETE ALL INSTALLATIONS AS INDICATED ON THE DRAWINGS.
- "KITTING LIST" SUPPLIED WITH THE BID PACKAGE IDENTIFIES ITEMS THAT WILL BE SUPPLIED BY CONTRACTOR. ITEMS NOT INCLUDED IN THE BILL OF MATERIALS AND KITTING LIST SHALL BE PROVIDED BY THE SUBCONTRACTOR.
- THE SUBCONTRACTOR SHALL INSTALL ALL EQUIPMENT AND MATERIALS IN ACCORDANCE WITH MANUFACTURERS RECOMMENDATIONS UNLESS SPECIFICALLY STATED OTHERWISE.
- IF THE SPECIFIED EQUIPMENT CANNOT BE INSTALLED AS SHOWN ON THESE DRAWINGS, THE SUBCONTRACTOR SHALL PROPOSED AND ALTERNATIVE INSTALLATION SPACE FOR APPROVAL BY CONTRACTOR.

- SUBCONTRACTOR SHALL DETERMINE ACTUAL ROUTING OF CONDUIT, POWER AND T1 CABLES, GROUNDING CABLES AS SHOWN ON THE POWER, GROUNDING AND TELCO PLAN DRAWING. SUBCONTRACTOR SHALL UTILIZE EXISTING TRAYS AND/OR SHALL ADD NEW TRAYS AS NECESSARY. SUBCONTRACTOR SHALL CONFIRM THE ACTUAL ROUTING WITH THE CONTRACTOR.
- THE SUBCONTRACTOR SHALL PROTECT THE EXISTING IMPROVEMENTS, PAVEMENTS, CURBS, LANDSCAPING AND STRUCTURES. ANY DAMAGED PART SHALL BE REPAIRED AT SUBCONTRACTORS EXPENSE TO THE SATISFACTION OF OWNER.
- SUBCONTRACTOR SHALL LEGALLY AND PROPERLY DISPOSE OF ALL SCRAP MATERIAL SUCH AS COAXIAL CABLE AND OTHER ITEMS REMOVED FROM THE EXISTING FACILITY. ANTENNAS REMOVED SHALL BE RETURNED TO THE OWNERS DESIGNATED LOCATION.
- SUBCONTRACTOR SHALL LEAVE PREMISES IN CLEAN CONDITION.
- ALL CONCRETE REPAIR WORK SHALL BE DONE IN ACCORDANCE WITH AMERICAN CONCRETE INSTITUTE (ACI) 301.
- ANY NEW CONCRETE NEEDED FOR THE CONSTRUCTION SHALL BE AIR-ENTRAINED AND SHALL HAVE 4000 PSI STRENGTH AT 28 DAYS. ALL CONCRETE WORK SHALL BE DONE IN ACCORDANCE WITH ACI 318 CODE REQUIREMENTS.
- ALL STRUCTURAL STEEL WORK SHALL BE DETAILED, FABRICATED AND ERECTED IN ACCORDANCE WITH AISC SPECIFICATIONS. ALL STRUCTURAL STEEL SHALL BE ASTM A36 (Fy = 36 ksi) UNLESS OTHERWISE NOTED. PIPES SHALL BE ASTM A53 TYPE E (Fy = 36 ksi). ALL STEEL EXPOSED TO WEATHER SHALL BE HOT DIPPED GALVANIZED. TOUCH UP ALL SCRATCHED AND OTHER MARKS IN THE FIELD AFTER STEEL IS ERRECTED USING A COMPATIBLE ZINC RICH PAINT.
- CONSTRUCTION SHALL COMPLY WITH UMS SPECIFICATIONS AND "GENERAL CONSTRUCTION SERVICES FOR CONSTRUCTION OF T-MOBILE SITES."
- SUBCONTRACTORS SHALL VERIFY ALL EXISTING DIMENSIONS AND CONDITIONS PRIOR TO COMMENCING ANY WORK. ALL DIMENSIONS OF EXISTING CONSTRUCTION SHOWN ON THE DRAWINGS MUST BE VERIFIED. SUBCONTRACTOR SHALL NOTIFY THE CONTRACTOR OF ANY DISCREPANCIES PRIOR TO ORDERING MATERIAL OR PROCEEDING WITH CONSTRUCTION.

18. THE EXISTING CELL SITE IS ACTIVE, ALL SAFETY PRECAUTIONS MUST BE TAKEN WHEN WORKING AROUND HIGH LEVELS OF ELECTROMAGNETIC RADIATION. EQUIPMENT SHOULD BE SHUTDOWN PRIOR TO PERFORMING ANY WORK THAT COULD EXPOSE THE WORKERS TO DANGER. PERSONAL RF EXPOSURE MONITORS ARE ADVISED TO BE WORN TO ALERT OF ANY DANGEROUS EXPOSURE LEVELS.

19. APPLICABLE BUILDING CODES:

SUBCONTRACTORS WORK SHALL COMPLY WITH ALL APPLICABLE NATIONAL, STATE AND LOCAL CODES AS ADOPTED BY THE LOCAL AUTHORITY HAVING JURISDICTION (AHJ) FOR THE LOCATION. THE EDITION OF THE AHJ ADOPTED CODES AND STANDARDS IN EFFECT ON THE DATE OF CONTRACT AWARD SHALL GOVERN THE DESIGN.

- BUILDING CODE: MA STATE BUILDING CODE 780 CMR 8TH EDITION
- ELECTRICAL CODE: REFER TO ELECTRICAL DRAWINGS
- LIGHTNING CODE: REFER TO ELECTRICAL DRAWINGS

SUBCONTRACTORS WORK SHALL COMPLY WITH THE LATEST EDITION OF THE FOLLOWING STANDARDS:

- AMERICAN CONCRETE INSTITUTE (ACI) 318; BUILDING CODE REQUIREMENT FOR STRUCTURAL CONCRETE
- AMERICAN INSTITUTE FOR STEEL CONSTRUCTION (AISC)
- MANUAL OF STEEL CONSTRUCTION, ASD, NINTH EDITION
- TELECOMMUNICATIONS INDUSTRY ASSOCIATION (TIA) 222-G, STRUCTURAL STANDARDS FOR STEEL
- ANTENNA TOWER AND ANTENNA SUPPORTING STRUCTURES; REFER TO ELECTRICAL DRAWINGS FOR SPECIFIC ELECTRICAL STANDARDS.

FOR ANY CONFLICTS BETWEEN SECTIONS OF LISTED CODES AND STANDARDS REGARDING MATERIAL, METHODS OF CONSTRUCTION, OR OTHER REQUIREMENTS, THE MOST RESTRICTIVE REQUIREMENT SHALL GOVERN. WHERE THERE IS A CONFLICT BETWEEN A GENERAL REQUIREMENT, THE SPECIFIC REQUIREMENT SHALL GOVERN.

## ELECTRICAL & GROUNDING NOTES

- THE SUBCONTRACTOR SHALL REVIEW AND INSPECT THE EXISTING FACILITY GROUNDING SYSTEM AND LIGHTNING PROTECTION SYSTEM (AS DESIGNED AND INSTALLED) FOR STRICT COMPLIANCE WITH THE NEC (AS ADOPTED BY THE AHJ), THE SITE SPECIFIC (UL, LPI, OR NFPA) LIGHTNING PROTECTION CODE, AND GENERAL COMPLIANCE WITH TELCORDIA AND TIA GROUNDING STANDARDS. THE SUBCONTRACTOR SHALL REPORT ANY VIOLATIONS OR ADVERSE FINDINGS TO THE CONTRACTOR FOR RESOLUTION.
- ALL GROUND ELECTRODE SYSTEMS (INCLUDING TELECOMMUNICATION, RADIO LIGHTNING PROTECTION AND AS POWER GES'S) SHALL BE BONDED TOGETHER, AT OR BELOW GRADE, BY TWO OR MORE COPPER BONDING CONDUCTORS IN ACCORDANCE WITH THE NEC.
- THE SUBCONTRACTOR SHALL PERFORM IEEE FALL-OF-POTENTIAL RESISTANCE TO EARTH TESTING (PER IEEE 1100 AND 81) FOR NEW GROUND ELECTRODE SYSTEMS. THE SUBCONTRACTOR SHALL FURNISH AND INSTALL SUPPLEMENTAL GROUND ELECTRODES AS NEEDED TO ACHIEVE A TEST RESULT OF 5 OHMS OR LESS.
- METAL RACEWAY SHALL NOT BE USED AS THE NEC REQUIRED EQUIPMENT GROUND CONDUCTOR. STRANDED COPPER CONDUCTORS WITH GREEN INSULATION, SIZED IN ACCORDANCE WITH THE NEC, SHALL BE FURNISHED AND INSTALLED WITH THE POWER CIRCUITS TO THE BTS EQUIPMENT.
- EACH BTS CABINET FRAME SHALL BE DIRECTLY CONNECTED TO THE MASTER GROUND BAR WITH GREEN INSULATED SUPPLEMENTAL EQUIPMENT GROUND WIRES, 6 AWG STRANDED COPPER OR LARGER FOR INDOOR BTS 2 AWG STRANDED COPPER FOR OUTDOOR BTS.
- EXOTHERMIC WELDS SHALL BE USED FOR ALL GROUNDING CONNECTIONS BELOW GRADE.
- APPROVED ANTIOXIDANT COATING (I.E. CONDUCTIVE GEL OR PASTE) SHALL BE USED ON ALL COMPRESSION AND BOLTED GROUND CONNECTIONS.
- ICE BRIDGE BONDING CONDUCTORS SHALL BE EXOTHERMICALLY BONDED OR BOLTED TO THE BRIDGE AND THE TOWER GROUND BAR.
- ALUMINUM CONDUCTOR OR COPPER CLAD STEEL CONDUCTOR SHALL NOT BE USED FOR GROUNDING CONNECTIONS.
- MISCELLANEOUS ELECTRICAL AND NON-ELECTRICAL METAL BOXES, FRAMES AND SUPPORTS SHALL BE BONDED TO THE GROUND RING, IN ACCORDANCE WITH THE NEC.

- METAL CONDUIT SHALL BE MADE ELECTRICALLY CONTINUOUS WITH LISTED BONDING FITTINGS OR BY BONDING ACROSS THE DISCONTINUITY WITH 6 AWS COPPER WIRE UL APPROVED GROUNDING TYPE CONDUIT CLAMPS.
- ALL NEW STRUCTURE WITH A FOUNDATION AND/OR FOOTING HAVING 20 FT. OR MORE OF 1/2 IN. OR GREATER ELECTRICALLY CONDUCTIVE REINFORCING RING USING AN EXOTHERMIC WELD CONNECTION USING #2 AWG SOLID BARE TINNED COPPER GROUND WIRE, PER NEC 250.50.
- ALL ELECTRICAL WORK SHALL CONFORM TO THE REQUIREMENTS OF THE NATIONAL ELECTRICAL CODE (NEC) AS WELL AS APPLICABLE STATE AND LOCAL CODES.
- ALL ELECTRICAL ITEMS SHALL BE U.L. APPROVED OR LISTED AND PROCURED PER SPECIFICATION REQUIREMENTS.
- THE ELECTRICAL WORK INCLUDES ALL LABOR AND MATERIAL DESCRIBED BY DRAWINGS AND SPECIFICATIONS INCLUDING INCIDENTAL WORK TO PROVIDE COMPLETE OPERATING AND APPROVED ELECTRICAL SYSTEM.
- GENERAL CONTRACTOR SHALL PAY FEES FOR PERMITS, AND IS RESPONSIBLE FOR OBTAINING SAID PERMITS AND COORDINATION OF INSPECTIONS.
- ELECTRICAL AND TELCO WIRING OUTSIDE A BUILDING AND EXPOSED TO WEATHER SHALL BE IN WATER TIGHT GALVANIZED RIGID STEEL CONDUITS OR SCHEDULE 80 PVC (AS PERMITTED BY CODE) AND WHERE REQUIRED IN LIQUID TIGHT FLEXIBLE METAL OR NONMETALLIC CONDUITS.
- RIGID STEEL CONDUITS SHALL BE GROUNDED AT BOTH ENDS.
- ELECTRICAL WIRING SHALL BE COPPER WITH TYPE XHHW, THWN OR THIN INSULATION.
- RUN ELECTRICAL CONDUIT OR CABLE BETWEEN ELECTRICAL ROOM AND PROPOSED CELL SITE POWER PEDESTAL AS INDICATED ON THIS DRAWING. PROVIDE FULL LENGTH PULL ROPE. COORDINATE INSTALLATION WITH UTILITY COMPANY.
- RUN TELCO CONDUIT OR CABLE BETWEEN TELEPHONE UTILITY DEMARCATION POINT AND PROPOSED CELL SITE TELCO CABINET AND BTS CABINET AS INDICATED ON DRAWING A-1. PROVIDE FULL LENGTH PULL ROPE IN INSTALLED TELCO CONDUIT. PROVIDE GREENLEE CONDUIT MEASURING TAPE AT EACH END.
- ALL EQUIPMENT LOCATED OUTSIDE SHALL HAVE NEMA 3R ENCLOSURE.

- GROUNDING SHALL COMPLY WITH NEW ART. 250.
- GROUND COAXIAL CABLE SHIELDS MINIMUM AT BOTH ENDS USING MANUFACTURERS COAX CABLE GROUNDING KITS SUPPLIED BY PROJECT OWNER.
- USE #6 COPPER STRANDED WIRE WITH GREEN COLOR INSULATION FOR ABOVE GRADE GROUNDING (UNLESS OTHERWISE SPECIFIED) AND #2 SOLID TINNED BARE COPPER WIRE FOR BELOW GRADE GROUNDING AS INDICATED ON DRAWING.
- ALL GROUND CONNECTIONS TO BE BURNDY HYGROUND COMPRESSION TYPE CONNECTORS OR CADWELD EXOTHERMIC WELD. DO NOT ALLOW BARE COPPER WIRE TO BE IN CONTACT WITH GALVANIZED STEEL.
- ROUTE GROUNDING CONDUCTORS ALONG THE SHORTEST AND STRAIGHTEST PATH POSSIBLE EXCEPT AS OTHERWISE INDICATED. GROUNDING LEADS SHOULD NEVER BE BENT AT RIGHT ANGLE. ALWAYS MAKE AT LEAST 12" RADIUS BENDS. #6 WIRE CAN BE BENT AT 6" RADIUS WHEN NECESSARY. BOND ANY METAL OBJECTS WITHIN 7 FEET OF PROPOSED EQUIPMENT OR CABINET TO MASTER GROUND BAR.
- CONNECTIONS TO MGB SHALL BE ARRANGED IN THREE MAIN GROUPS: SURGE PRODUCERS (COAXIAL CABLE GROUND KITS, TELCO AND POWER PANEL GROUND); (GROUNDING ELECTRODE RING OR BUILDING STEEL); NON-SURGING OBJECTS (EGB GROUND IN BTS UNIT)
- CONNECTIONS TO GROUND BARS SHALL BE MADE WITH TWO HOLE COMPRESSION TYPE COPPER LUGS. APPLY OXIDE INHIBITING COMPOUND TO ALL LOCATIONS.
- BOND ANTENNA MOUNTING BRACKETS. COAXIAL CABLE GROUND KITS AND ALNA TO EGB PLACES NEAR THE ANTENNA LOCATION.
- BOND ANTENNA EGB'S AND MGB TO WATER MAIN.
- TEST COMPLETED GROUND SYSTEM AND RECORD RESULTS FOR PROJECT CLOSE-OUT DOCUMENTATION.
- BOND ANY METAL OBJECTS WITHIN 7 FEET OF PROPOSED EQUIPMENT OR CABINET TO MASTER GROUND BAR.
- VERIFY PROPOSED SERVICE UPGRADE WITH LOCAL UTILITY COMPANY PRIOR TO CONSTRUCTION.

## ABBREVIATIONS

AGL	ABOVE GRADE LEVEL	G.C.	GENERAL CONTRACTOR	RF	RADIO FREQUENCY
AWG	AMERICAN WIRE GAUGE	MGB	MASTER GROUND BUS		
BCW	BARE COPPER WIRE	MIN	MINIMUM	TBD	TO BE DETERMINED
BTS	BASE TRANSCEIVER STATION	PROPOSED	NEW	TBR	TO BE REMOVED
EXISTING	EXISTING	N.T.S.	NOT TO SCALE	TBRR	TO BE REMOVED AND REPLACED
EG	EQUIPMENT GROUND	REF	REFERENCE		
EGR	EQUIPMENT GROUND RING	REQ	REQUIRED	TYP	TYPICAL

**COM-EX**  
Consultants

115 ROUTE 46  
SUITE E39  
MOUNTAIN LAKES, NJ 07046  
PHONE: 862.209.4300  
FAX: 862.209.4301

**T-Mobile**

**T-MOBILE NORTHEAST LLC**

15 COMMERCE WAY, SUITE B  
NORTON, MA 02766  
OFFICE: (508) 286-2700  
FAX: (508) 286-2893

Documents prepared by Com-Ex Consultants, including this document, are to be used only for the specific project and specific use for which they were intended. Any extension of use to any other projects, by owner or by any other party, without the expressed written consent of Com-Ex Consultants, is done unlawfully and at the users own risk. If used in a way other than that specifically intended, user will hold Com-Ex Consultants, harmless from all claims and losses.

## SCHEDULE OF REVISIONS

REV NO.	DATE	DESCRIPTION OF CHANGES
7		
6		
5		
4		
3		
2	08/27/20	ISSUED AS FINAL
1	07/23/20	REVISED PER RF COMMENTS
0	06/30/20	INITIAL SUBMISSION

**DRAWN BY:** WG  
**CHECKED BY:** CJT  
**SCALE:** AS NOTED  
**JOB NO:** 20002-TRN

INFORMATION ON THIS SET OF DRAWINGS IS NOT FOR OFFICIAL USE UNLESS ACCOMPANIED BY THE STAMPED SEAL & SIGNATURE OF A PROFESSIONAL ENGINEER

  
NICHOLAS D. BARILE  
PROFESSIONAL ENGINEER

**NICHOLAS D. BARILE**  
PROFESSIONAL ENGINEER, MA LIC. No. 51464

**SITE #: 4DE7032A**  
**B0032/1923-1925 MASS AVE**  
**1923-1925 MASSACHUSETTS AVE.**  
**CAMBRIDGE, MA 02140**  
**MIDDLESEX COUNTY**

**DRAWING TITLE:**

**GROUNDING & GENERAL NOTES**

**DRAWING SHEET: 2 OF 7**

**GN-1**

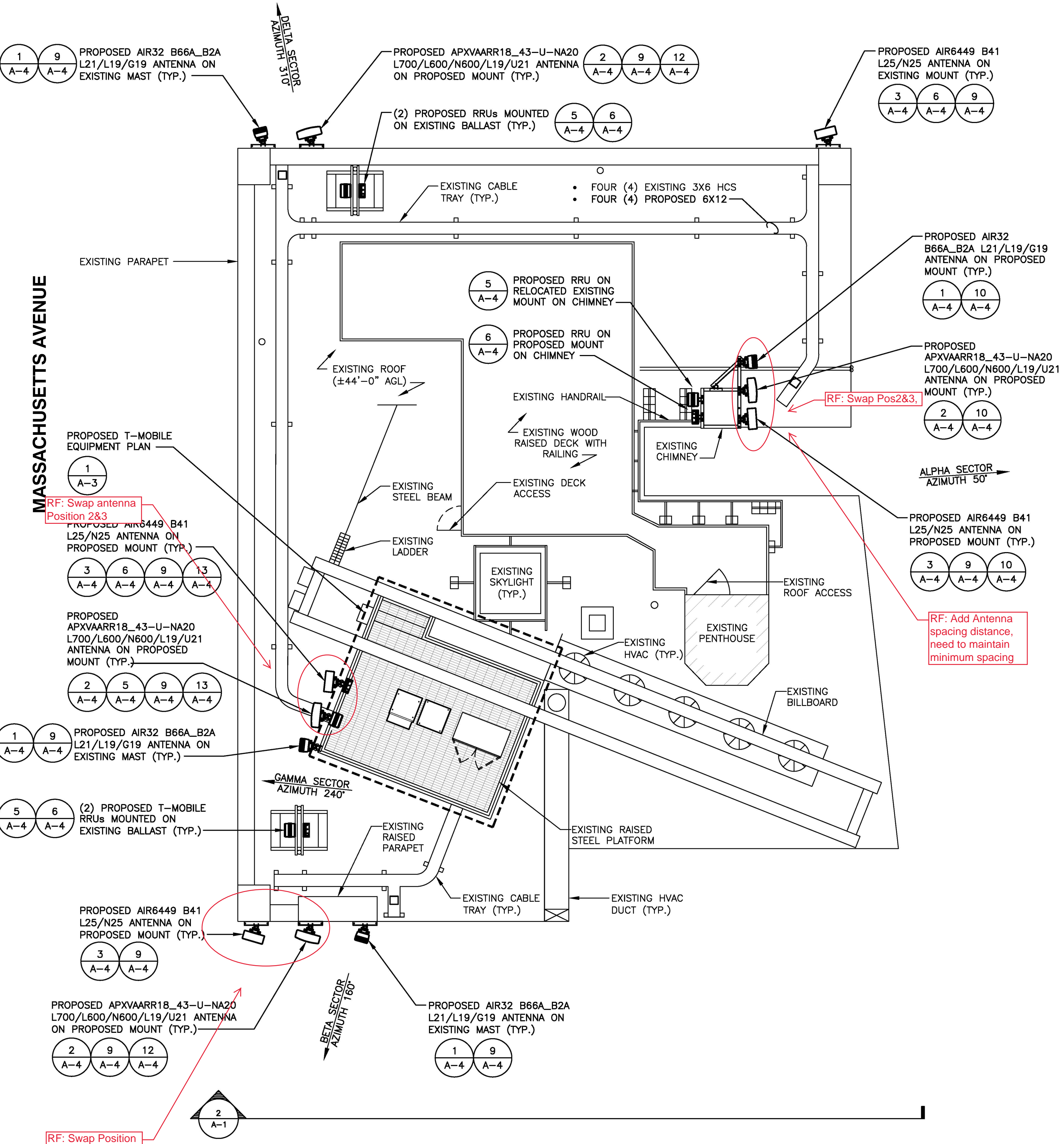
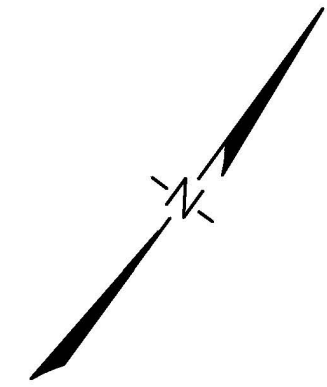

1 ROOF PLAN  
SCALE: 3/16"=1'-0"  
GRAPHIC SCALE: 3/16"=1'-0"

ALL LOADING ASSOCIATED WITH PROPOSED EQUIPMENT CABINETS, ANTENNAS, AND CABLE ROUTING SHALL BE VERIFIED BY A PASSING STRUCTURAL ANALYSIS PERFORMED BY A LICENSED ENGINEER PRIOR TO INSTALLATION

LOADING SHOWN ON THIS SET OF DRAWINGS IS BASED ON THE STRUCTURAL ANALYSIS & MOUNT ANALYSIS PERFORMED BY COM-EX CONSULTANTS, DATED AUGUST 27, 2020. CONTRACTOR TO NOTIFY COM-EX AND T-MOBILE IN THE EVENT SITE CONDITIONS DIFFER FROM WHAT IS REPRESENTED IN THE STRUCTURAL ANALYSIS. NO SUBSTITUTIONS ARE PERMITTED WITHOUT ADDITIONAL ANALYSIS.

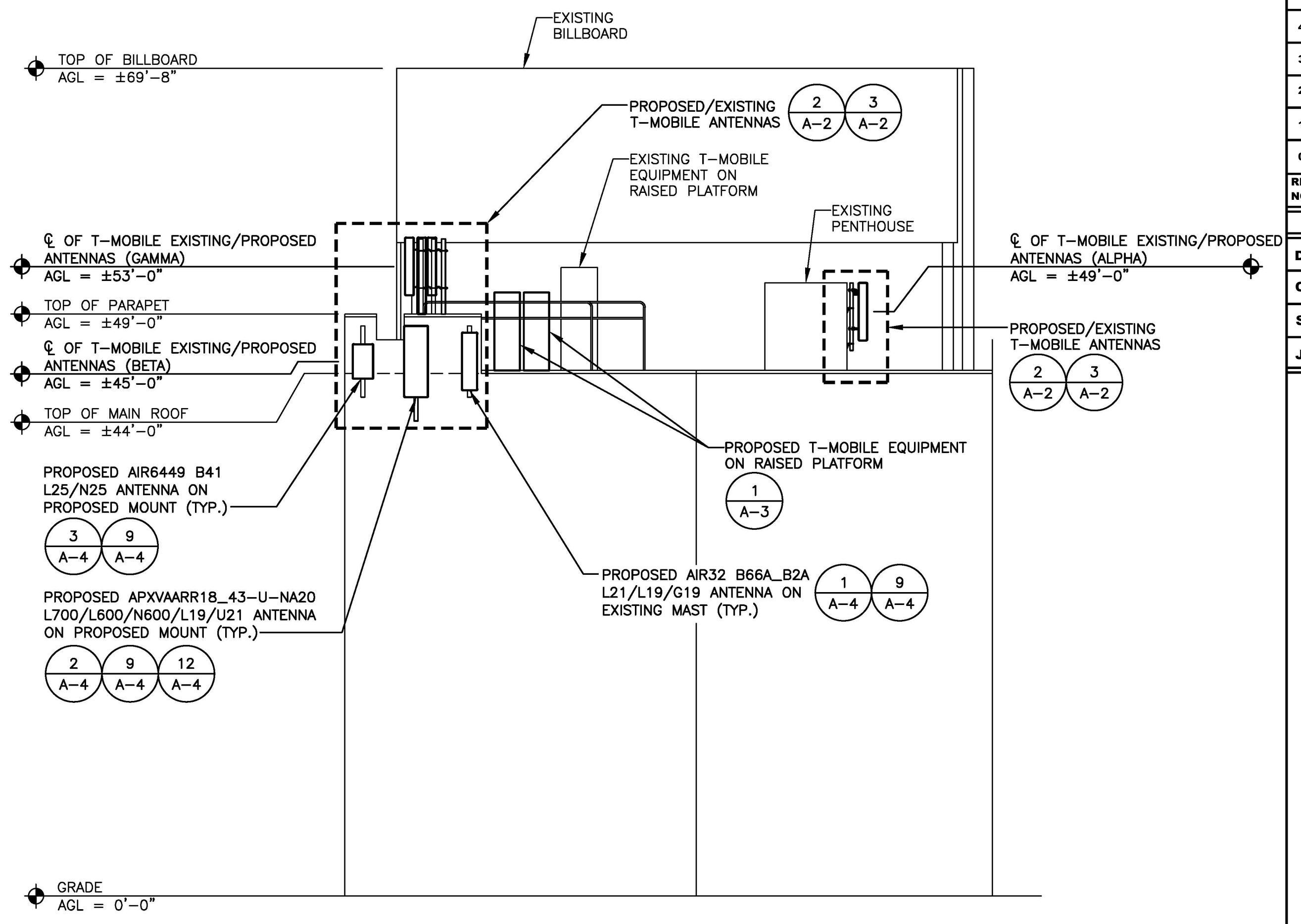

2 ELEVATION  
SCALE: 1/8"=1'-0"  
GRAPHIC SCALE: 1/8"=1'-0"

**COM-EX** Consultants  
115 ROUTE 46 SUITE E39  
MOUNTAIN LAKES, NJ 07046  
PHONE: 862.209.4300  
FAX: 862.209.4301

**T-Mobile**  
T-MOBILE NORTHEAST LLC  
15 COMMERCE WAY, SUITE B  
NORTON, MA 02766  
OFFICE: (508) 286-2700  
FAX: (508) 286-2893

Documents prepared by Com-Ex Consultants, including this document, are to be used only for the specific project and specific use for which they were intended. Any extension of use to any other projects, by owner or by any other party, without the expressed written consent of Com-Ex Consultants, is done unlawfully and at the users own risk. If used in a way other than that specifically intended, user will hold Com-Ex Consultants, harmless from all claims and losses.

SCHEDULE OF REVISIONS		
REV NO.	DATE	DESCRIPTION OF CHANGES
7		
6		
5		
4		
3		
2	08/27/20	ISSUED AS FINAL
1	07/23/20	REVISED PER RF COMMENTS
0	06/30/20	INITIAL SUBMISSION

DRAWN BY: WG  
CHECKED BY: CJT  
SCALE: AS NOTED  
JOB NO: 20002-TRN

INFORMATION ON THIS SET OF DRAWINGS IS NOT FOR OFFICIAL USE UNLESS ACCOMPANIED BY THE STAMPED SEAL & SIGNATURE OF A PROFESSIONAL ENGINEER

**NICHOLAS D. BARILE**  
PROFESSIONAL ENGINEER, MA LIC. No. 51464

**SITE #: 4DE7032A**  
**BO032/1923-1925 MASS AVE**  
**1923-1925 MASSACHUSETTS AVE.**  
**CAMBRIDGE, MA 02140**  
**MIDDLESEX COUNTY**

DRAWING TITLE:  
**ROOF PLAN & ELEVATION**

DRAWING SHEET: 3 OF 7

**A-1**

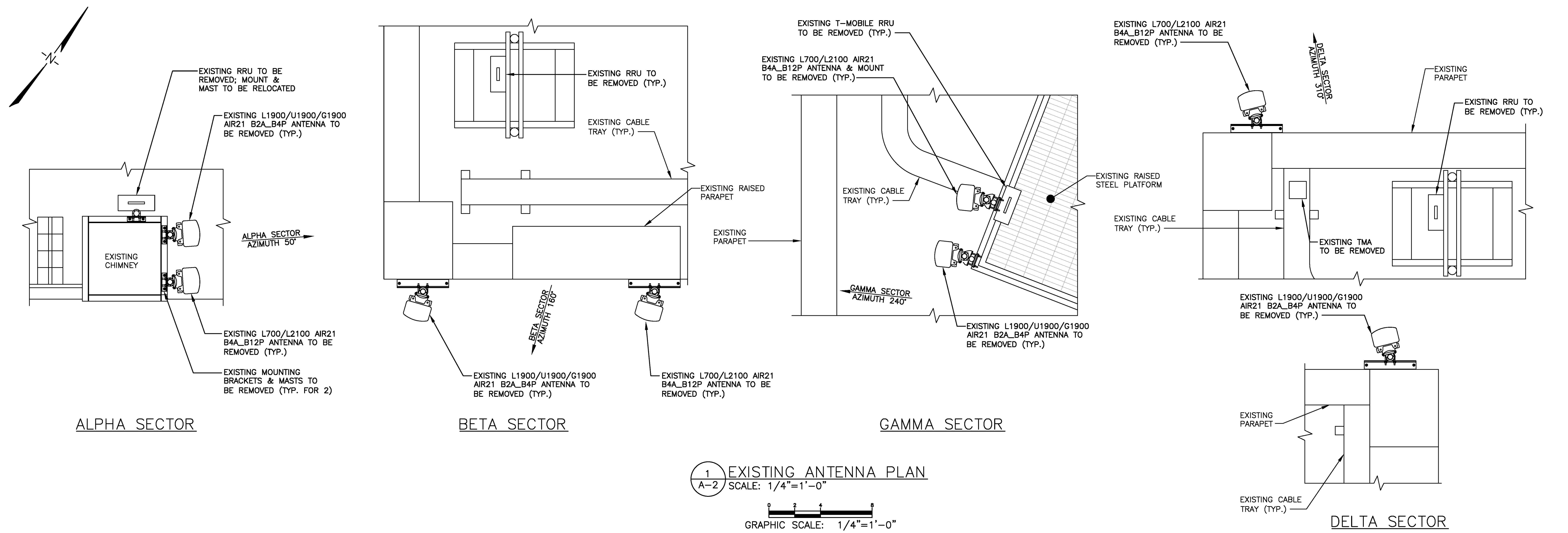

1 EXISTING ANTENNA PLAN  
A-2 SCALE: 1/4"=1'-0"

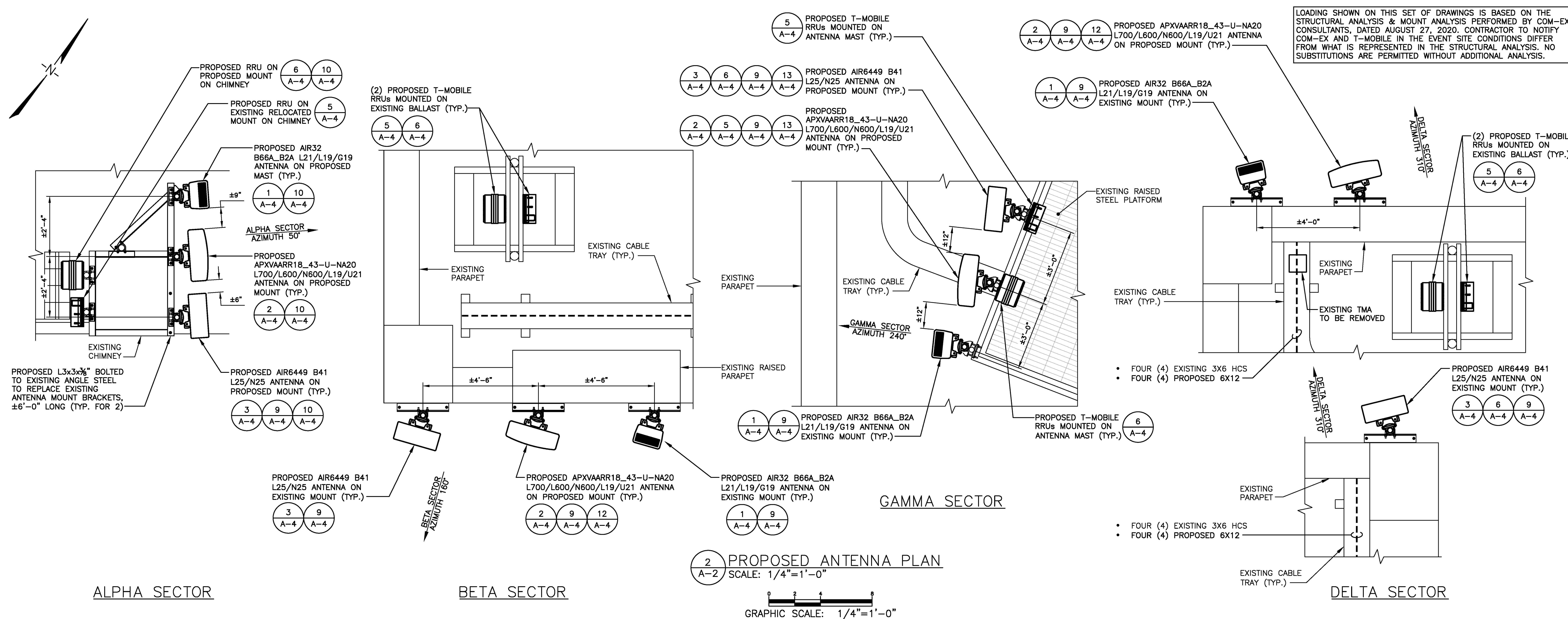

2 PROPOSED ANTENNA PLAN  
A-2 SCALE: 1/4"=1'-0"

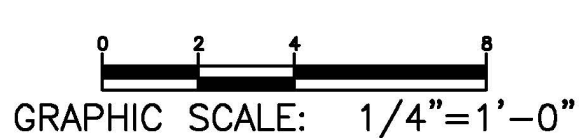

**COM-EX Consultants**  
115 ROUTE 46 SUITE E39  
MOUNTAIN LAKES, NJ 07046  
PHONE: 862.209.4300  
FAX: 862.209.4301

**T-Mobile**  
T-MOBILE NORTHEAST LLC  
15 COMMERCE WAY, SUITE B  
NORTON, MA 02766  
OFFICE: (508) 286-2700  
FAX: (508) 286-2893

Documents prepared by Com-Ex Consultants, including this document, are to be used only for the specific project and specific use for which they were intended. Any extension of use to any other projects, by owner or by any other party, without the expressed written consent of Com-Ex Consultants, is done unlawfully and at the users own risk. If used in a way other than that specifically intended, user will hold Com-Ex Consultants, harmless from all claims and losses.

**SCHEDULE OF REVISIONS**

REV. NO.	DATE	DESCRIPTION OF CHANGES
7		
6		
5		
4		
3		
2	08/27/20	ISSUED AS FINAL
1	07/23/20	REVISED PER RF COMMENTS
0	06/30/20	INITIAL SUBMISSION

**DRAWN BY:** WG  
**CHECKED BY:** CJT  
**SCALE:** AS NOTED  
**JOB NO.:** 20002-TRN

LOADING SHOWN ON THIS SET OF DRAWINGS IS BASED ON THE STRUCTURAL ANALYSIS & MOUNT ANALYSIS PERFORMED BY COM-EX CONSULTANTS, DATED AUGUST 27, 2020. CONTRACTOR TO NOTIFY COM-EX AND T-MOBILE IN THE EVENT SITE CONDITIONS DIFFER FROM WHAT IS REPRESENTED IN THE STRUCTURAL ANALYSIS. NO SUBSTITUTIONS ARE PERMITTED WITHOUT ADDITIONAL ANALYSIS.

INFORMATION ON THIS SET OF DRAWINGS IS NOT FOR OFFICIAL USE UNLESS ACCOMPANIED BY THE STAMPED SEAL & SIGNATURE OF A PROFESSIONAL ENGINEER

**NICHOLAS D. BARILE**  
PROFESSIONAL ENGINEER, MA LIC. No. 51464

**SITE #: 4DE7032A**  
**BO032/1923-1925 MASS AVE**  
**1923-1925 MASSACHUSETTS AVE.**  
**CAMBRIDGE, MA 02140**  
**MIDDLESEX COUNTY**

**EXISTING & PROPOSED ANTENNA PLANS**

**DRAWING SHEET: 4 OF 7**

**A-2**

**SITE CONFIGURATION: 4SEC-67D5997DB OUTDOOR**

LOADING SHOWN ON THIS SET OF DRAWINGS IS BASED ON THE STRUCTURAL ANALYSIS & MOUNT ANALYSIS PERFORMED BY COM-EX CONSULTANTS, DATED AUGUST 27, 2020. CONTRACTOR TO NOTIFY COM-EX AND T-MOBILE IN THE EVENT SITE CONDITIONS DIFFER FROM WHAT IS REPRESENTED IN THE STRUCTURAL ANALYSIS. NO SUBSTITUTIONS ARE PERMITTED WITHOUT ADDITIONAL ANALYSIS.

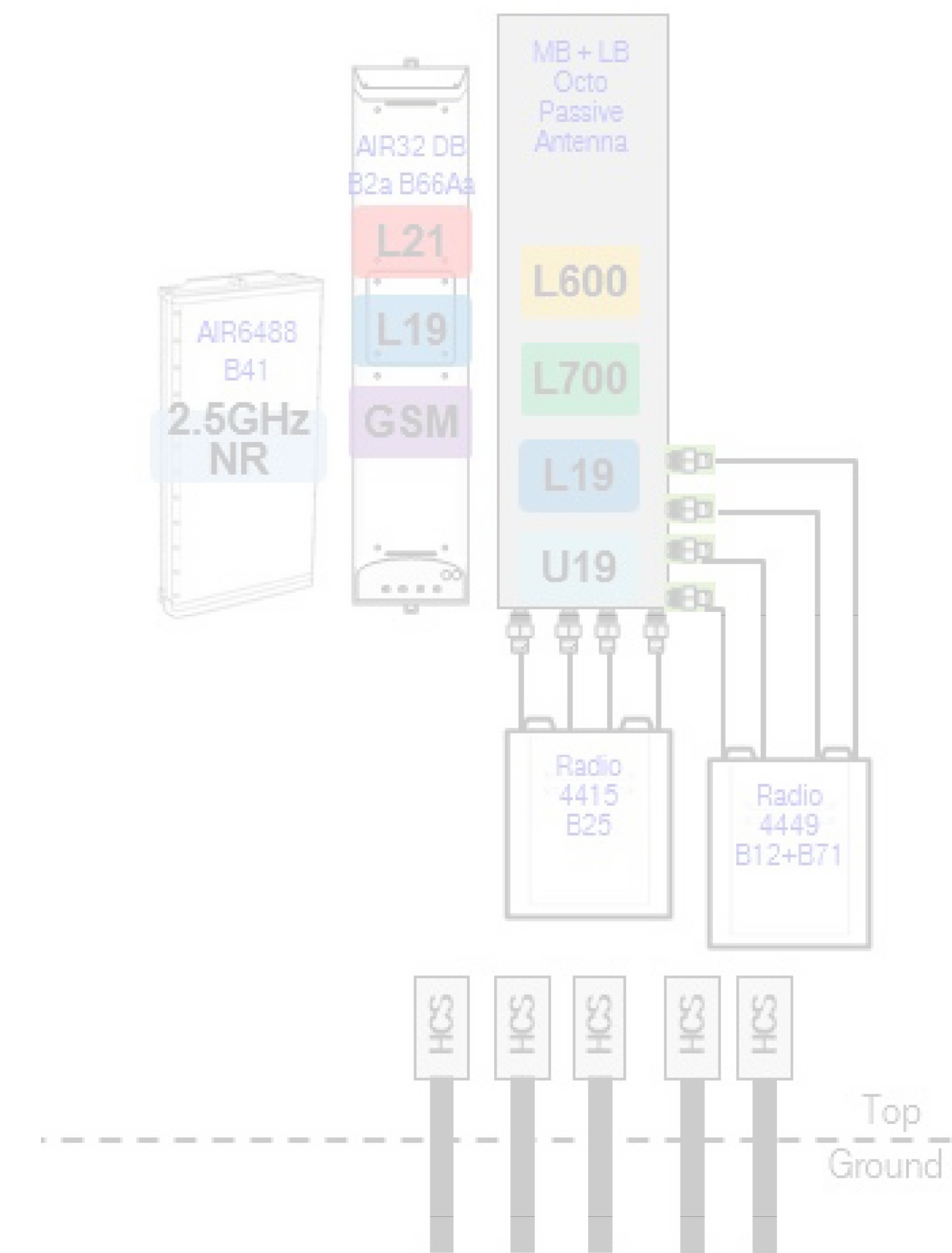
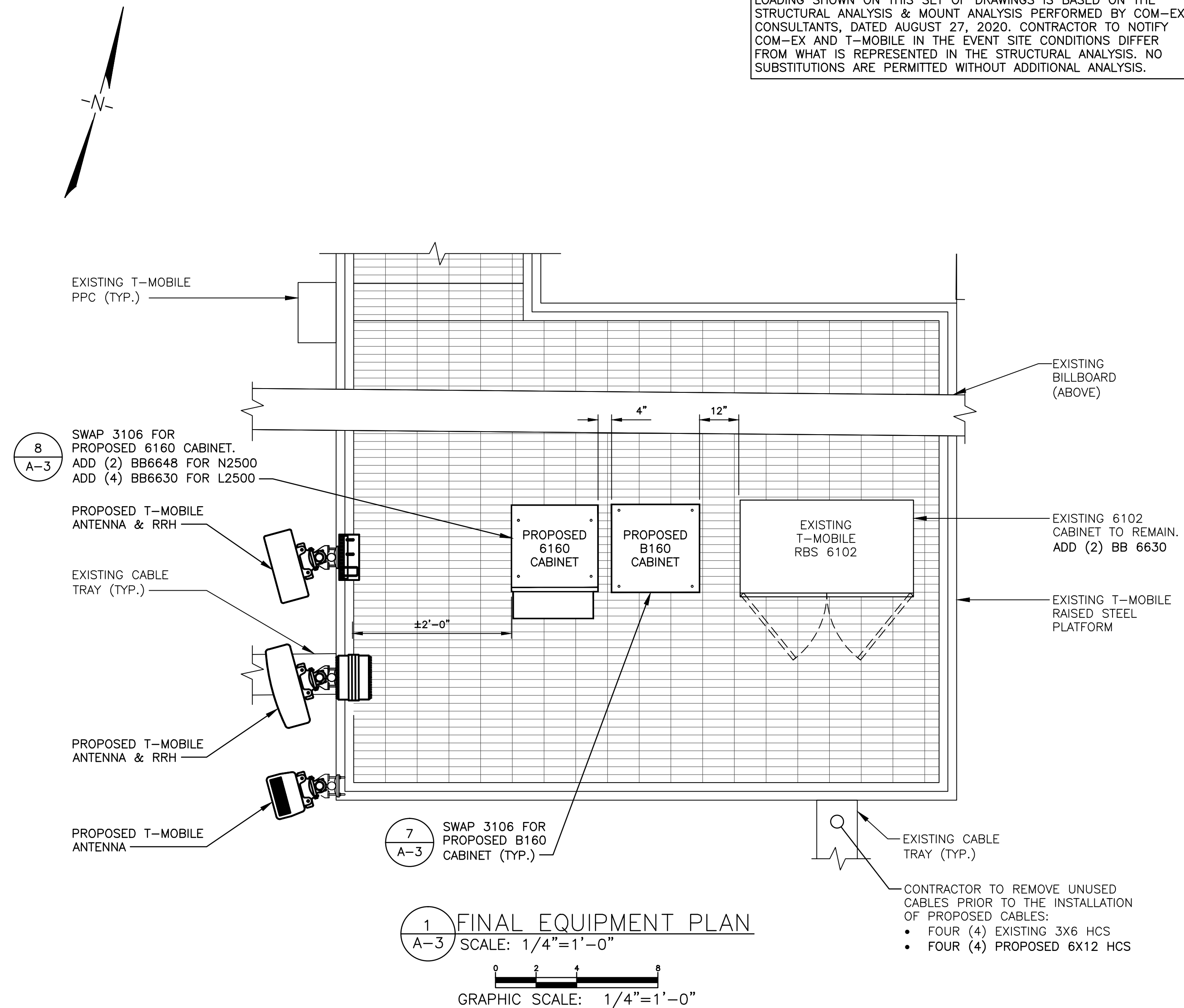

ANTENNA INFORMATION															
SECTOR	POSITION (FROM REAR LEFT TO RIGHT)	EXISTING		PROPOSED											
		MODEL	QTY.	MODEL	ANT. C.L.	SECTOR MARK	QTY.	E-TILT	M-TILT	RRU MODEL/QUANTITY	TMA	COAX/FIBER QUANTITY	COAX/FIBER SIZE	COAX/FIBER LENGTH	
ALPHA 50°	R1	AIR21 B2A_B4P	1	AIR32 B66A_B2A	49°-0"	L1900/G1900/L2100	1	3/3/3/3	0	-	-	4	1	FIBER JUMPER 6x12 HCS	15' 100'
	R2	AIR21 B4A_B12P	1	APXVAARR18.43-U-NA20	49°-0"	N600/L600/L700/L1900/U2100	1	4/4/3/3	0	(1) 4449 B71+B85 (1) 4415 B25	(1) TWIN STYLE 1B-AWS	12 4 2	COAX JUMPER FIBER JUMPER 1/2" COAX	15' 15' 100'	
	R3	-	-	AIR6449 B41	49°-0"	L2500/N2500	1	2/2	0	-	-	4	4	FIBER JUMPER COAX JUMPER	15' 15'
BETA 160°	W1	AIR21 B2A_B4P	1	AIR32 B66A_B2A	45°-0"	L1900/G1900/L2100	1	3/3/3/3	0	-	-	4	1	FIBER JUMPER 6x12 HCS	15' 100'
	W2	AIR21 B4A_B12P	1	APXVAARR18.43-U-NA20	45°-0"	N600/L600/L700/L1900/U2100	1	4/4/3/3	0	(1) 4449 B71+B85 (1) 4415 B25	(1) TWIN STYLE 1B-AWS	12 4 2	COAX JUMPER FIBER JUMPER 1/2" COAX	15' 15' 100'	
	W3	-	-	AIR6449 B41	45°-0"	L2500/N2500	1	2/2	0	-	-	4	4	FIBER JUMPER COAX JUMPER	15' 15'
GAMMA 240°	B1	AIR21 B2A_B4P	1	AIR32 B66A_B2A	53°-0"	L1900/G1900/L2100	1	3/3/3/3	0	-	-	4	1	FIBER JUMPER 6x12 HCS	15' 100'
	B2	AIR21 B4A_B12P	1	APXVAARR18.43-U-NA20	53°-0"	N600/L600/L700/L1900/U2100	1	4/4/3/3	0	(1) 4449 B71+B85 (1) 4415 B25	(1) TWIN STYLE 1B-AWS	12 4 2	COAX JUMPER FIBER JUMPER 1/2" COAX	15' 15' 100'	
	B3	-	-	AIR6449 B41	53°-0"	L2500/N2500	1	2/2	0	-	-	4	4	FIBER JUMPER COAX JUMPER	15' 15'
DELTA 310°	B1	AIR21 B4A_B12P	1	AIR32 B66A_B2A	45°-0"	L1900/G1900/L2100	1	3/3/3/3	0	-	-	4	1	FIBER JUMPER 6x12 HCS	15' 100'
	B2	AIR21 B2A_B4P	1	APXVAARR18.43-U-NA20	45°-0"	N600/L600/L700/L1900/U2100	1	4/4/3/3	0	(1) 4449 B71+B85 (1) 4415 B25	(1) TWIN STYLE 1B-AWS	1	COAX JUMPER FIBER JUMPER 1/2" COAX	15' 15' 100'	
	B3	-	-	AIR6449 B41	45°-0"	L2500/N2500	1	2/2	0	-	-	4	4	FIBER JUMPER COAX JUMPER	15' 15'

AT TIME OF CONSTRUCTION, CONTRACTOR TO VERIFY AZIMUTHS OF EXISTING ANTENNAS. IF DIFFERENT FROM RFDS, PLEASE NOTIFY THE RF ENGINEER AND CONSTRUCTION MANAGER WITH ACTUAL AZIMUTH TO ENSURE T-MOBILE'S DATABASE IS ACCURATE AND UP-TO-DATE.

ANTENNA LOCATIONS TO BE VERIFIED IN FIELD. RFDS TO BE REDLINED ACCORDINGLY.  
INFORMATION SHOWN PROVIDED ON T-MOBILE RFDS DATE 05/21/20

NOTE: EXISTING SITE CONDITIONS SHOW ON THIS SET OF PLANS BASED ON A VISIT BY COM-EX ON 06/16/20.

**COM-EX Consultants**  
115 ROUTE 46 SUITE E39  
MOUNTAIN LAKES, NJ 07046  
PHONE: 862.209.4300  
FAX: 862.209.4301

**T-Mobile**  
T-MOBILE NORTHEAST LLC  
15 COMMERCE WAY, SUITE B  
NORTON, MA 02766  
OFFICE: (508) 286-2700  
FAX: (508) 286-2893

Documents prepared by Com-Ex Consultants, including this document, are to be used only for the specific project and specific use for which they were intended. Any extension of use to any other projects, by owner or by any other party, without the expressed written consent of Com-Ex Consultants, is done unlawfully and at the users own risk. If used in a way other than that specifically intended, user will hold Com-Ex Consultants, harmless from all claims and losses.

**SCHEDULE OF REVISIONS**

REV NO.	DATE	DESCRIPTION OF CHANGES
7		
6		
5		
4		
3		
2	08/27/20	ISSUED AS FINAL
1	07/23/20	REVISED PER RF COMMENTS
0	06/30/20	INITIAL SUBMISSION

DRAWN BY: WG  
CHECKED BY: CJT  
SCALE: AS NOTED  
JOB NO: 20002-TRN

INFORMATION ON THIS SET OF DRAWINGS IS NOT FOR OFFICIAL USE UNLESS ACCOMPANIED BY THE STAMPED SEAL & SIGNATURE OF A PROFESSIONAL ENGINEER

*Nicholas D. Barile*  
NICHOLAS D. BARILE  
REGISTERED PROFESSIONAL ENGINEER  
STATE OF MASSACHUSETTS  
LICENSE NO. 10157

**NICHOLAS D. BARILE**  
PROFESSIONAL ENGINEER, MA LIC. No. 51464

**SITE #: 4DE7032A**  
**B0032/1923-1925 MASS AVE**  
**1923-1925 MASSACHUSETTS AVE.**  
**CAMBRIDGE, MA 02140**  
**MIDDLESEX COUNTY**

DRAWING TITLE:  
**FINAL EQUIPMENT PLAN & SCHEMATIC**

DRAWING SHEET: 4 OF 7

**A-3**

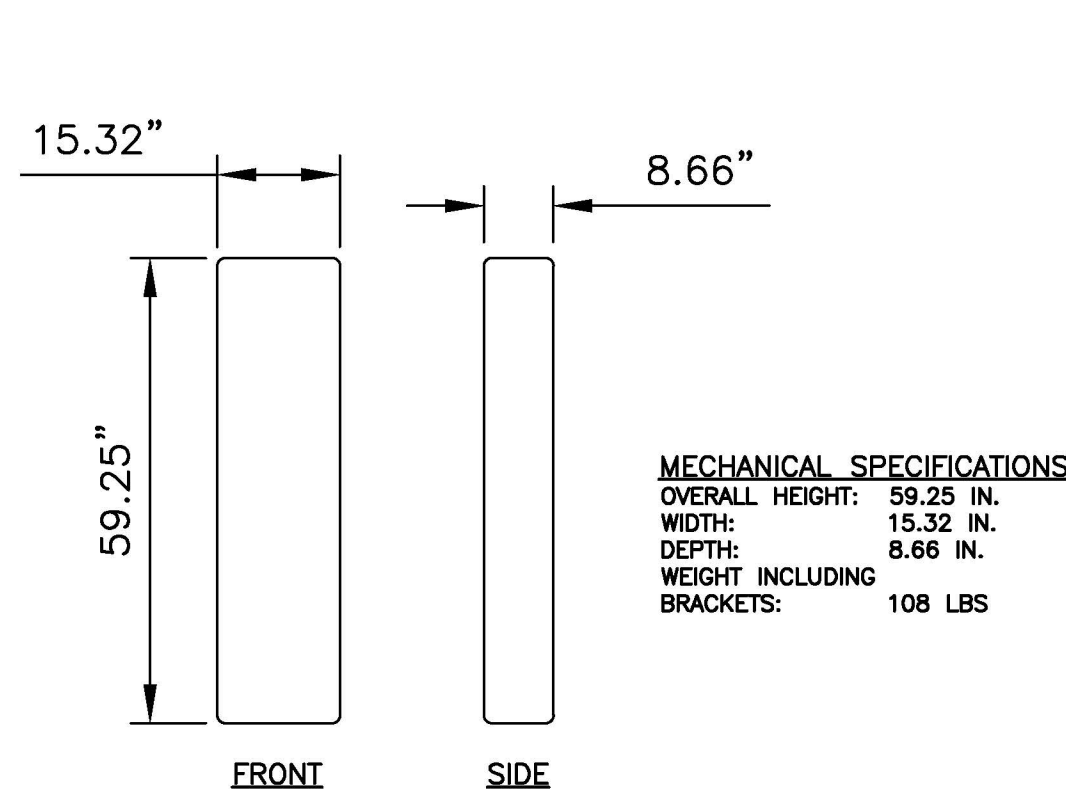

1  
A-4  
PROPOSED ANTENNA - AIR32B66A\_B2A  
SCALE: 1/2"=1'

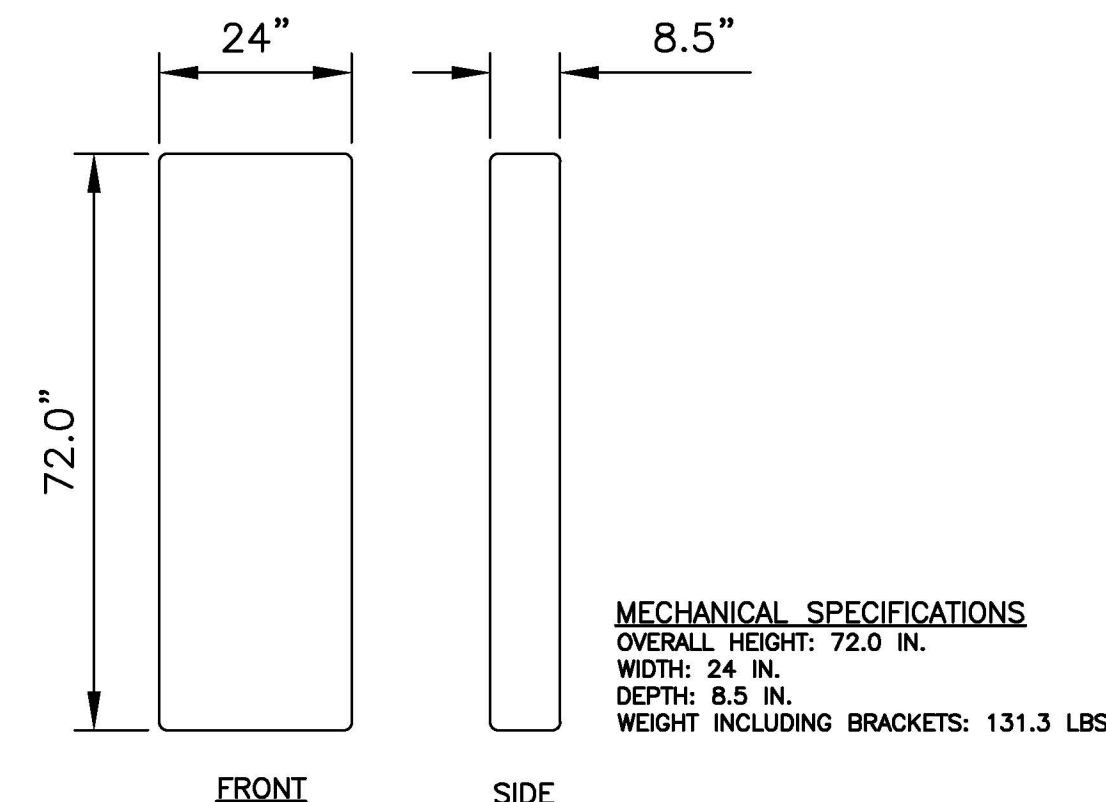

2  
A-4  
PROPOSED ANTENNA - APXVAARR18-43-U-NA20  
SCALE: 1/2"=1'

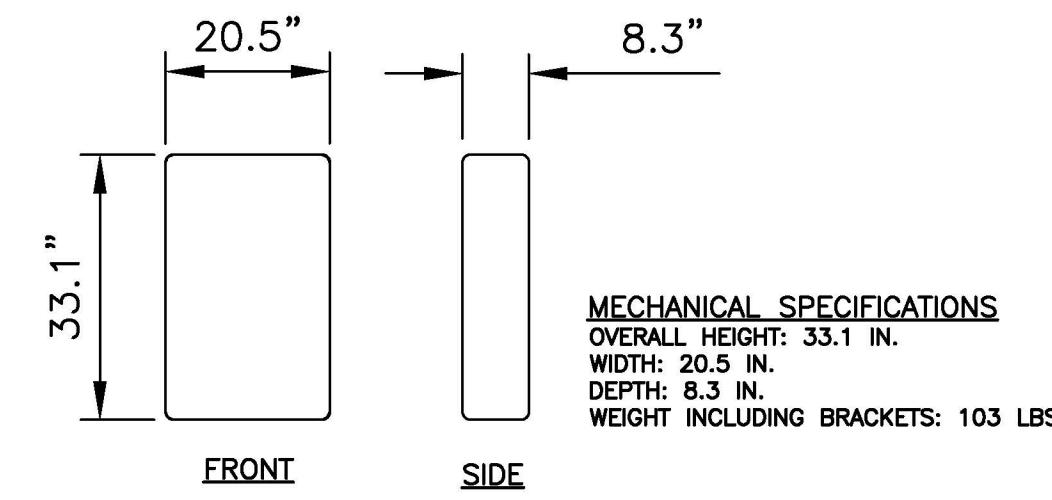

3  
A-4  
PROPOSED ANTENNA - AIR6449 B41  
SCALE: 1/2"=1'

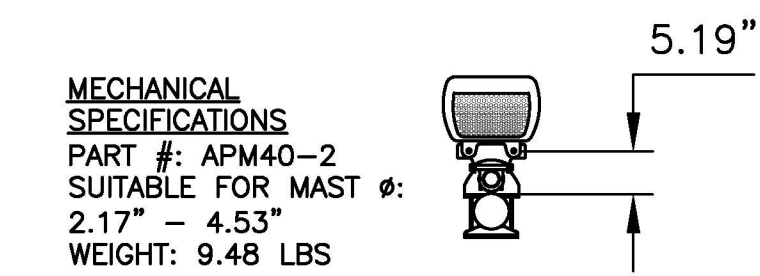

4  
A-4  
TYPICAL ANTENNA MOUNTING DETAIL  
SCALE: 1/2"=1'

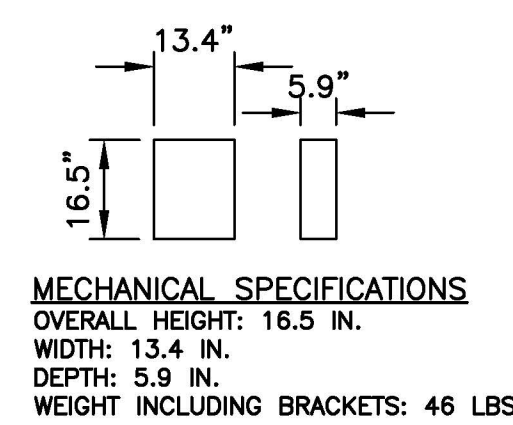

5  
A-4  
PROPOSED RRU - 4415 B25  
SCALE: 3/8"=1'

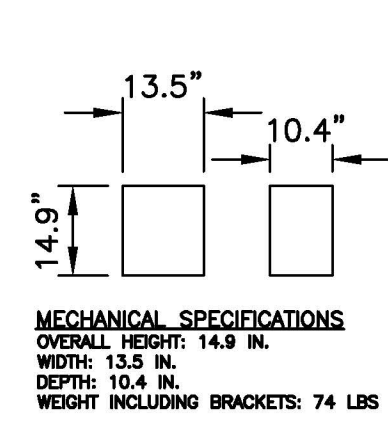

6  
A-4  
PROPOSED RRU - 4449 B71+B85  
SCALE: 3/8"=1'

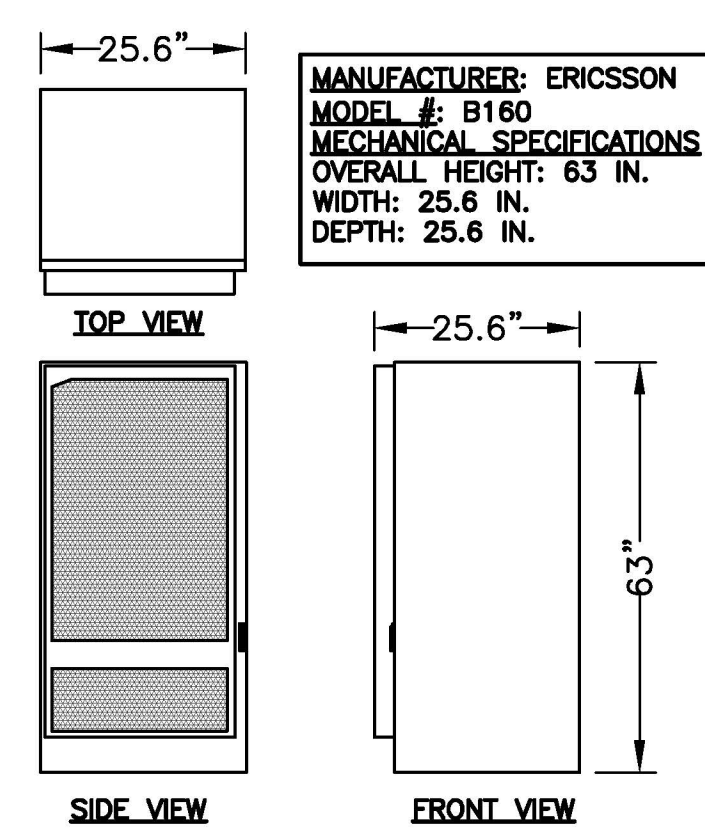

7  
A-4  
ERICSSON - B160 CABINET  
SCALE: N.T.S.

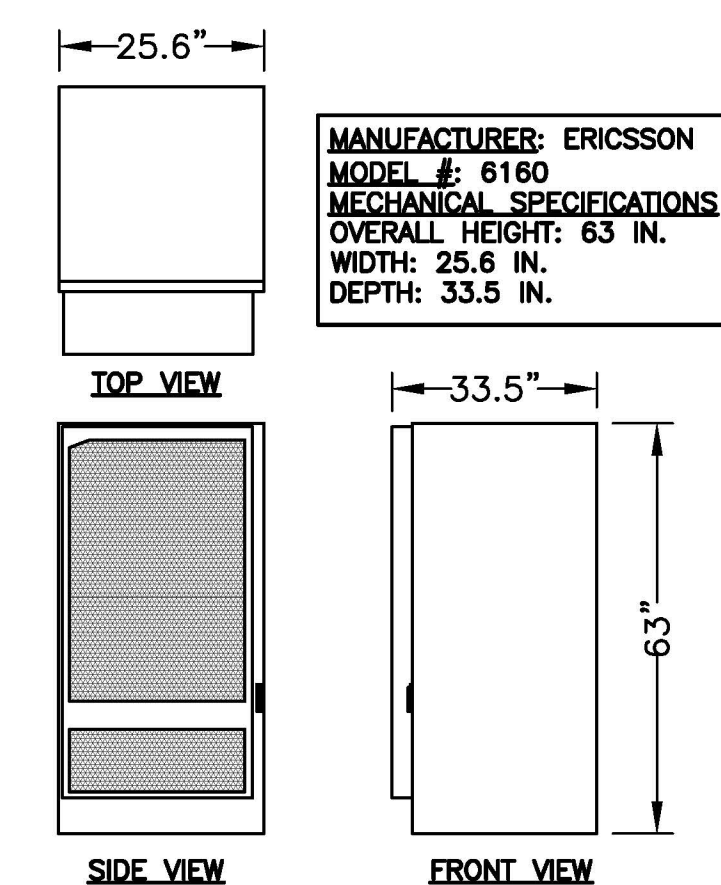

8  
A-4  
ERICSSON - 6160 CABINET  
SCALE: N.T.S.

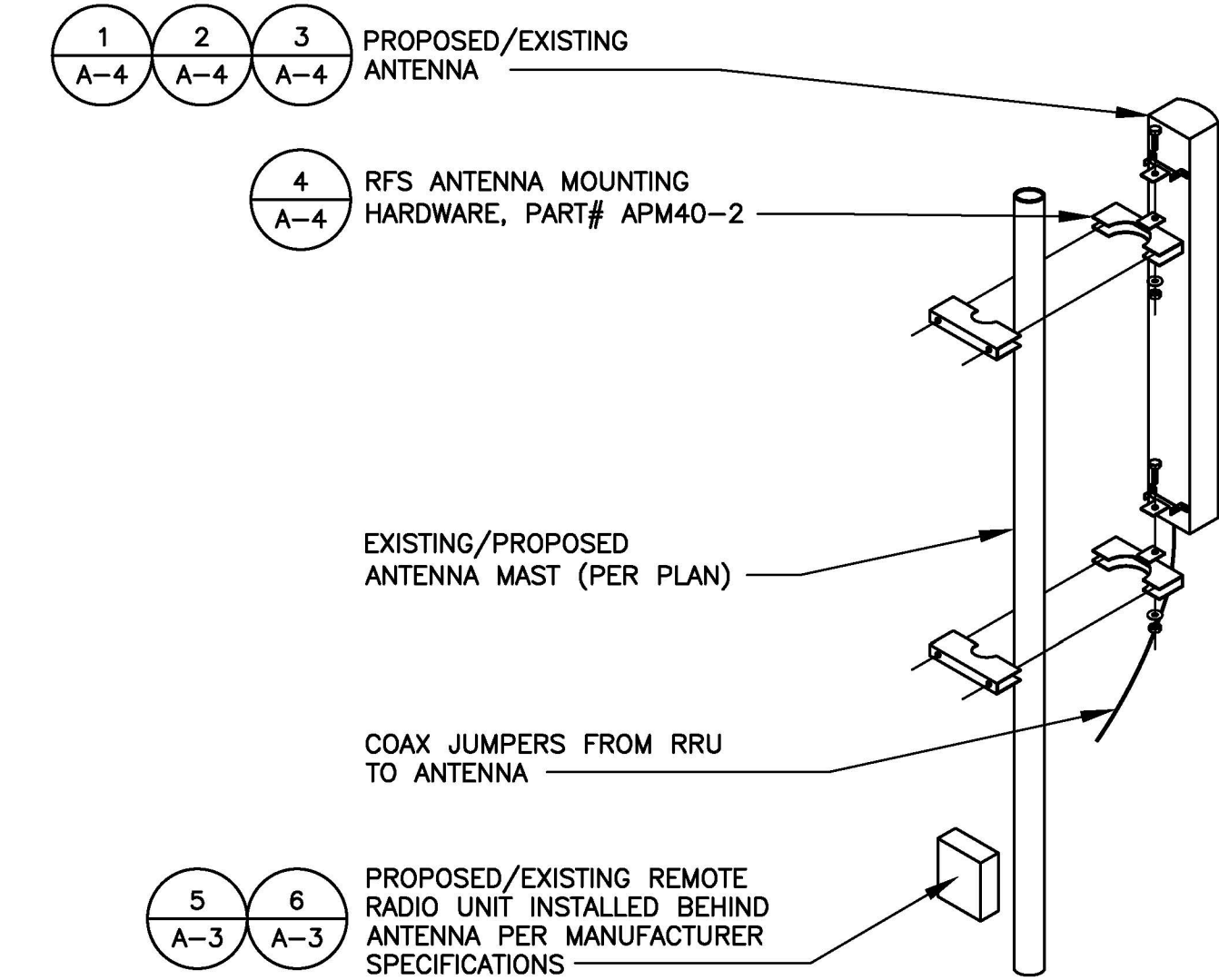

9  
A-4  
TYPICAL ANTENNA INSTALLATION DETAIL  
SCALE: N.T.S.

**NOTE:**  
 • ANTENNAS NOT SHOWN FOR CLARITY.  
 • PROPOSED ANTENNAS, FRAME & RRU TO BE PAINTED TO MATCH.  
 • PROVIDE NON-SHRINK GROUT AT INTERFACE OF WALL & MOUNT.

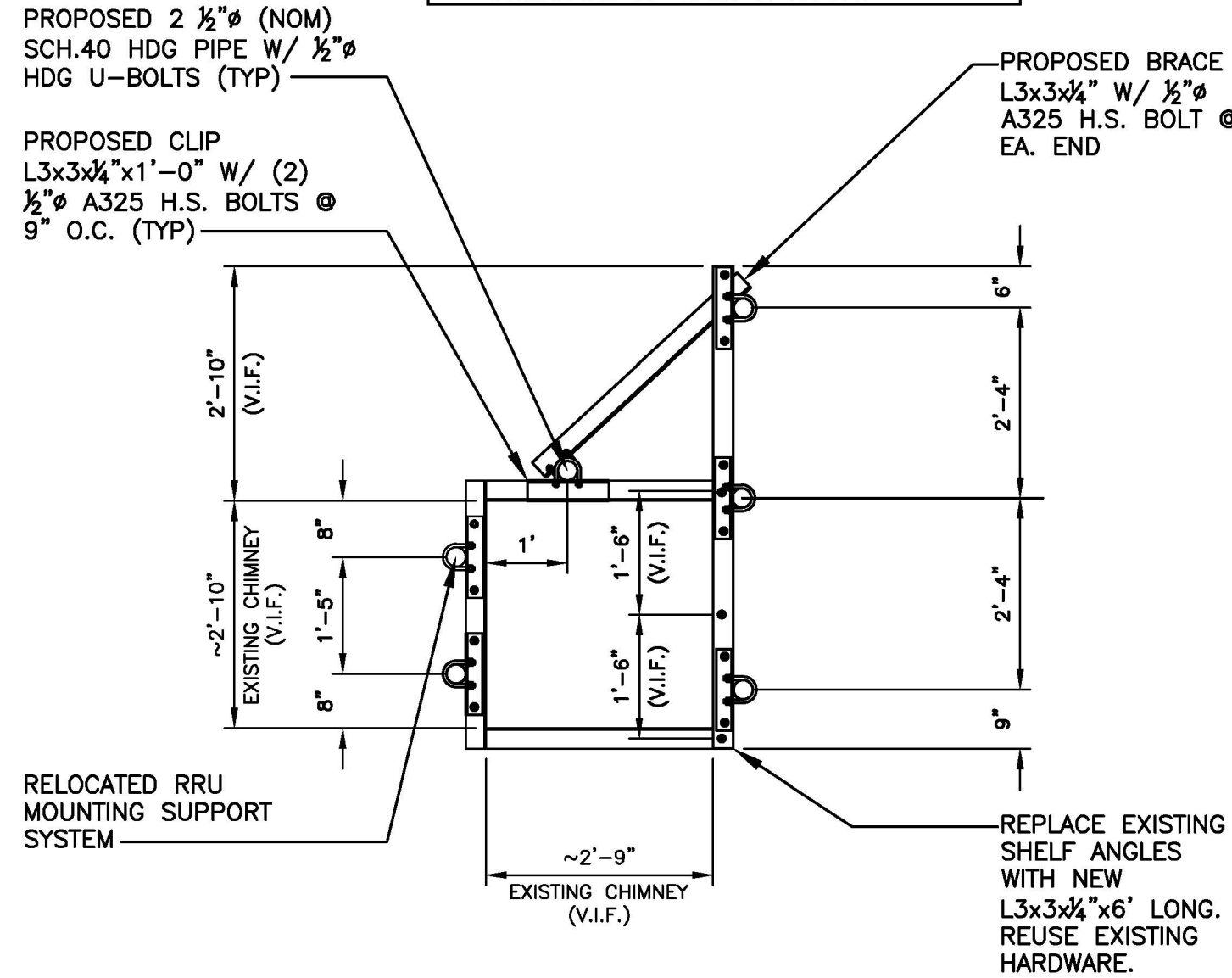

10  
A-4  
ALPHA SECTOR ANTENNA MOUNTING DETAIL  
SCALE: N.T.S.

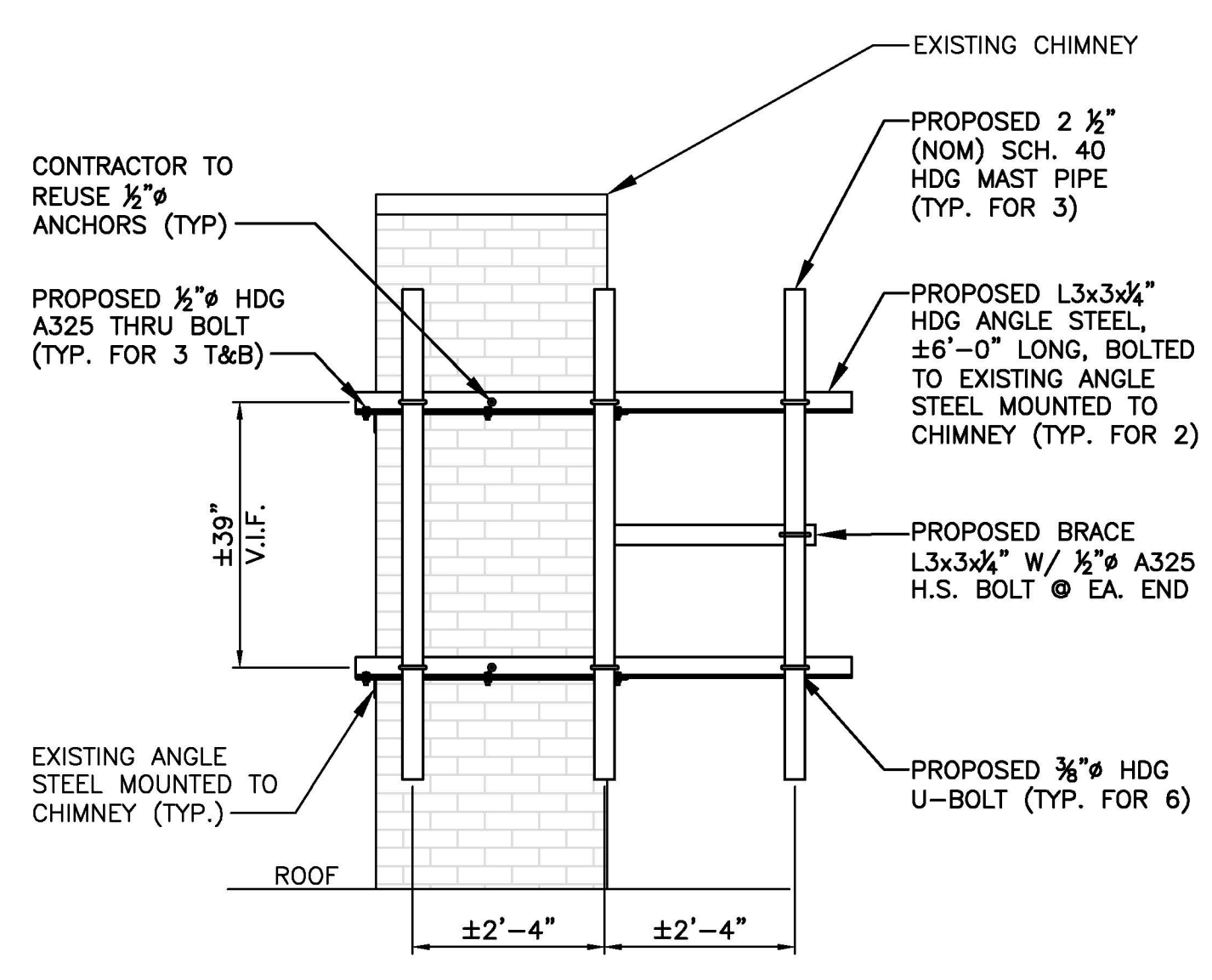

11  
A-4  
ALPHA SECTOR ANTENNA MOUNTING DETAIL  
SCALE: N.T.S.

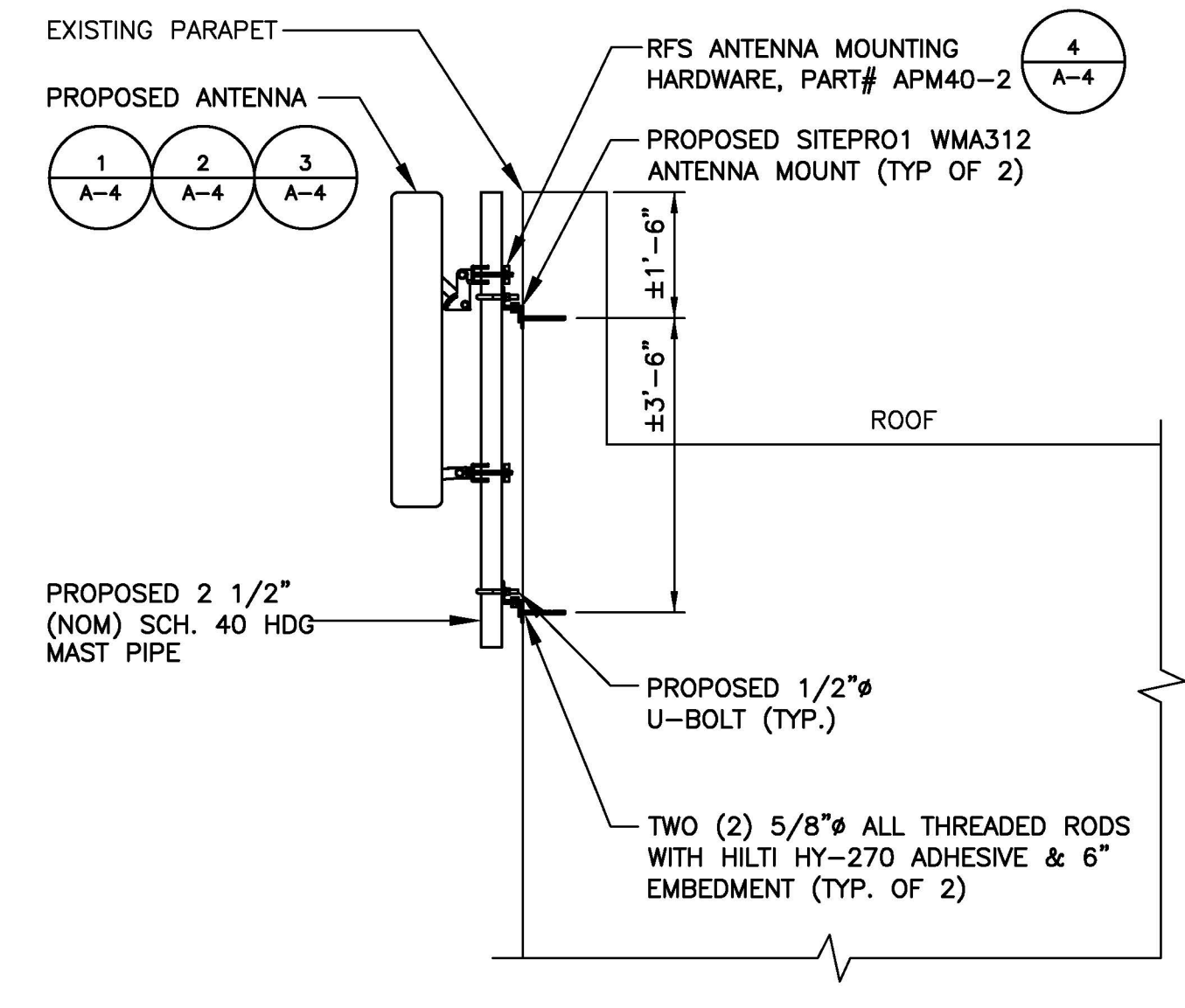

12  
A-4  
BETA & DELTA SECTOR ANTENNA MOUNTING DETAIL  
SCALE: N.T.S.

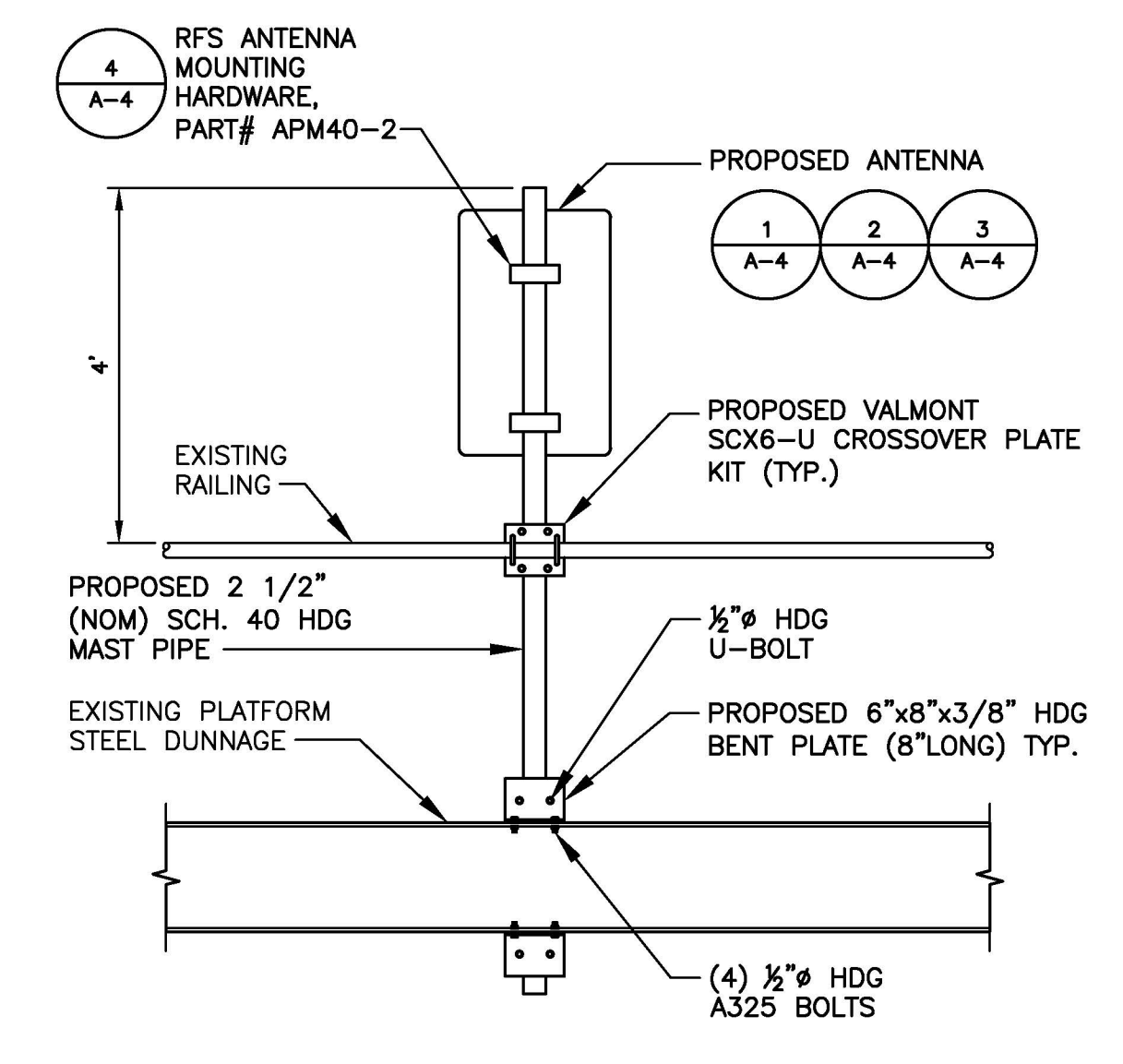

13  
A-4  
GAMMA SECTOR ANTENNA MOUNTING DETAIL  
SCALE: N.T.S.

LOADING SHOWN ON THIS SET OF DRAWINGS IS BASED ON THE STRUCTURAL ANALYSIS & MOUNT ANALYSIS PERFORMED BY COM-EX CONSULTANTS, DATED AUGUST 27, 2020. CONTRACTOR TO NOTIFY COM-EX AND T-MOBILE IN THE EVENT SITE CONDITIONS DIFFER FROM WHAT IS REPRESENTED IN THE STRUCTURAL ANALYSIS. NO SUBSTITUTIONS ARE PERMITTED WITHOUT ADDITIONAL ANALYSIS.

Documents prepared by Com-Ex Consultants, including this document, are to be used only for the specific project and specific use for which they were intended. Any extension of use to any other projects, by owner or by any other party, without the expressed written consent of Com-Ex Consultants, is done unlawfully and at the users own risk. If used in a way other than that specifically intended, user will hold Com-Ex Consultants, harmless from all claims and losses.

**SCHEDULE OF REVISIONS**

REV NO.	DATE	DESCRIPTION OF CHANGES
7		
6		
5		
4		
3		
2	08/27/20	ISSUED AS FINAL
1	07/23/20	REVISED PER RF COMMENTS
0	06/30/20	INITIAL SUBMISSION

**DRAWN BY:** WG  
**CHECKED BY:** CJT  
**SCALE:** AS NOTED  
**JOB NO:** 20002-TRN

INFORMATION ON THIS SET OF DRAWINGS IS NOT FOR OFFICIAL USE UNLESS ACCOMPANIED BY THE STAMPED SEAL & SIGNATURE OF A PROFESSIONAL ENGINEER

*Nicholas D. Barile*  
 NICHOLAS D. BARILE  
 PROFESSIONAL ENGINEER  
 STATE OF MASSACHUSETTS  
 LICENSE NO. 10122  
 EXPIRES 12/31/2024

**NICHOLAS D. BARILE**  
 PROFESSIONAL ENGINEER, MA LIC. No. 51464

**SITE #: 4DE7032A**  
**B0032/1923-1925 MASS AVE**  
**1923-1925 MASSACHUSETTS AVE.**  
**CAMBRIDGE, MA 02140**  
**MIDDLESEX COUNTY**

**DRAWING TITLE:**

**DETAILS**

**DRAWING SHEET: 5 OF 7**

**A-4**

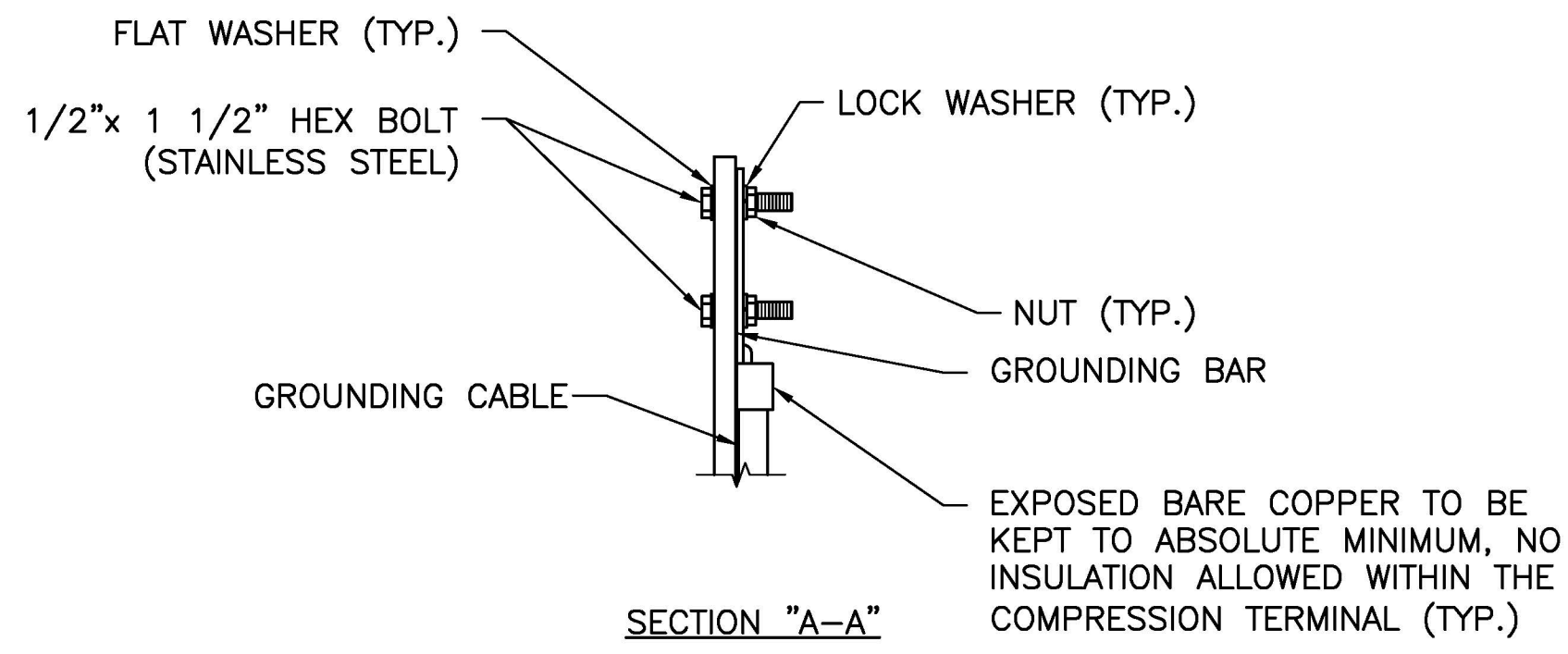

- NOTE:**
- "DOUBLING UP" OR "STACKING" OF CONNECTIONS IS NOT PERMITTED.
  - OXIDE INHIBITING COMPOUND TO BE USED AT ALL LOCATIONS.

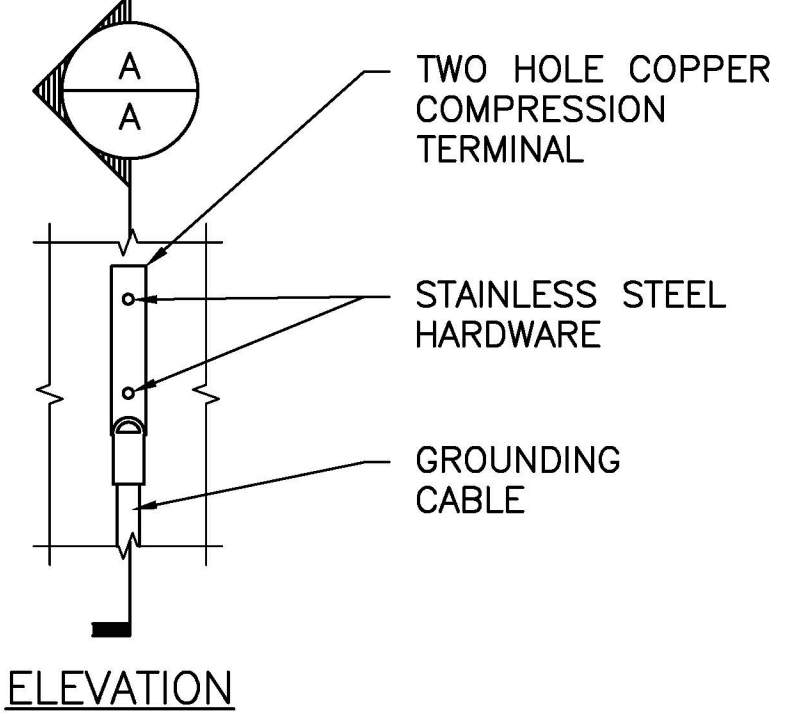

**1**  
E-1 TYPICAL GROUND BAR CONNECTION DETAIL  
SCALE: N.T.S.

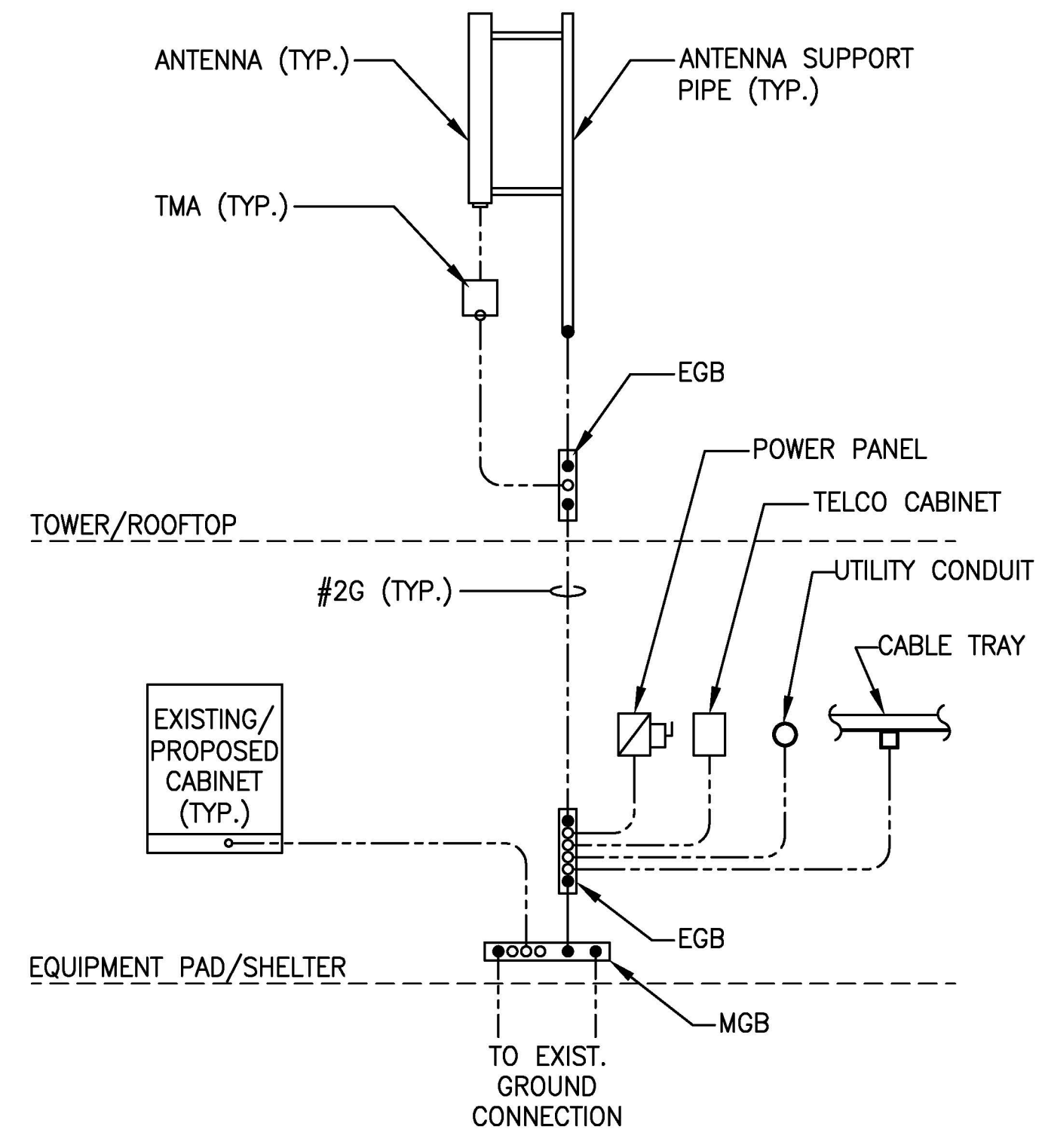

**2**  
E-1 GROUNDING RISER DIAGRAM  
SCALE: N.T.S.

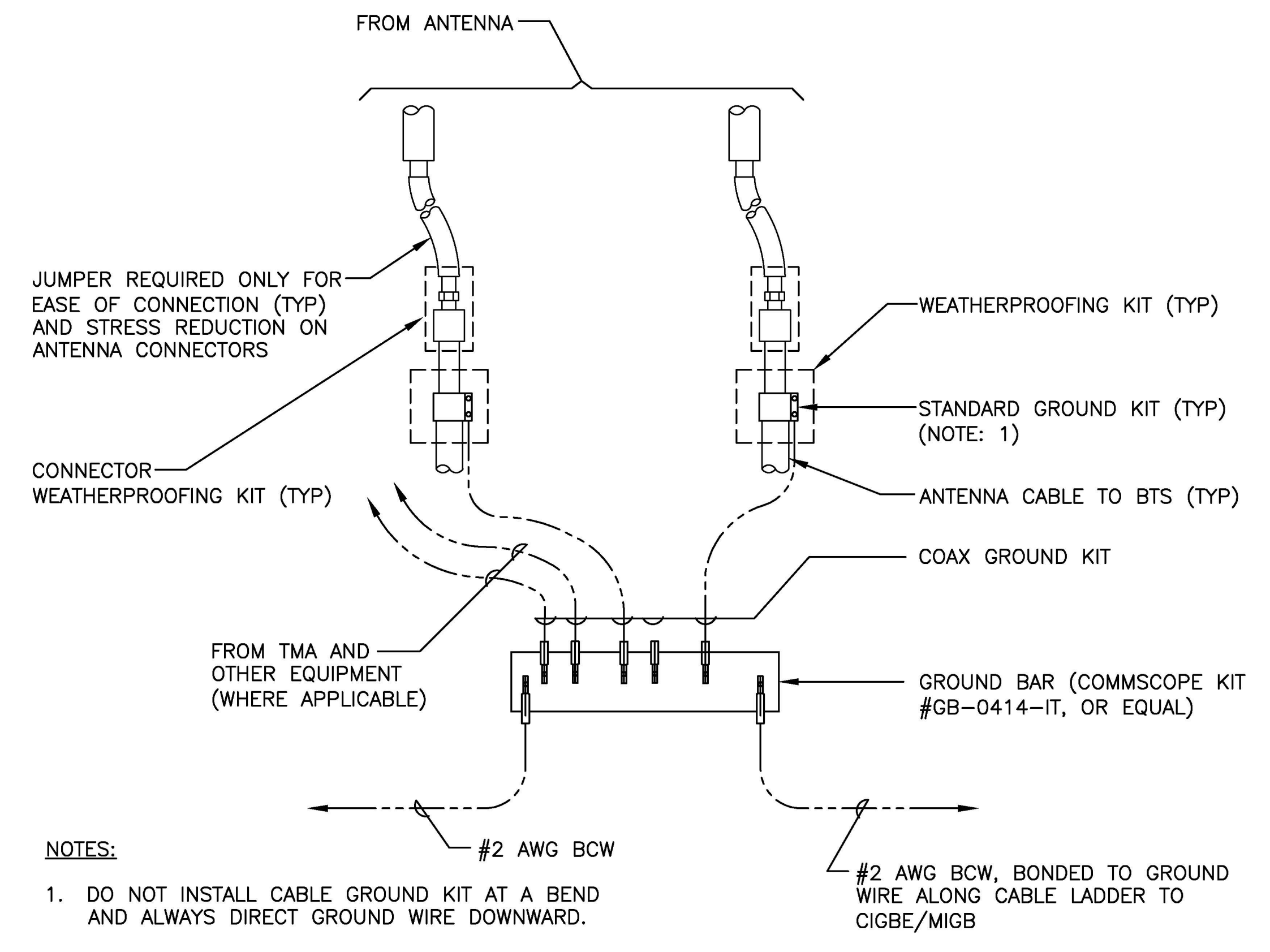

- NOTES:**
- DO NOT INSTALL CABLE GROUND KIT AT A BEND AND ALWAYS DIRECT GROUND WIRE DOWNWARD.

**3**  
E-1 GROUND WIRE TO GROUND BAR CONNECTION DETAIL  
SCALE: N.T.S.

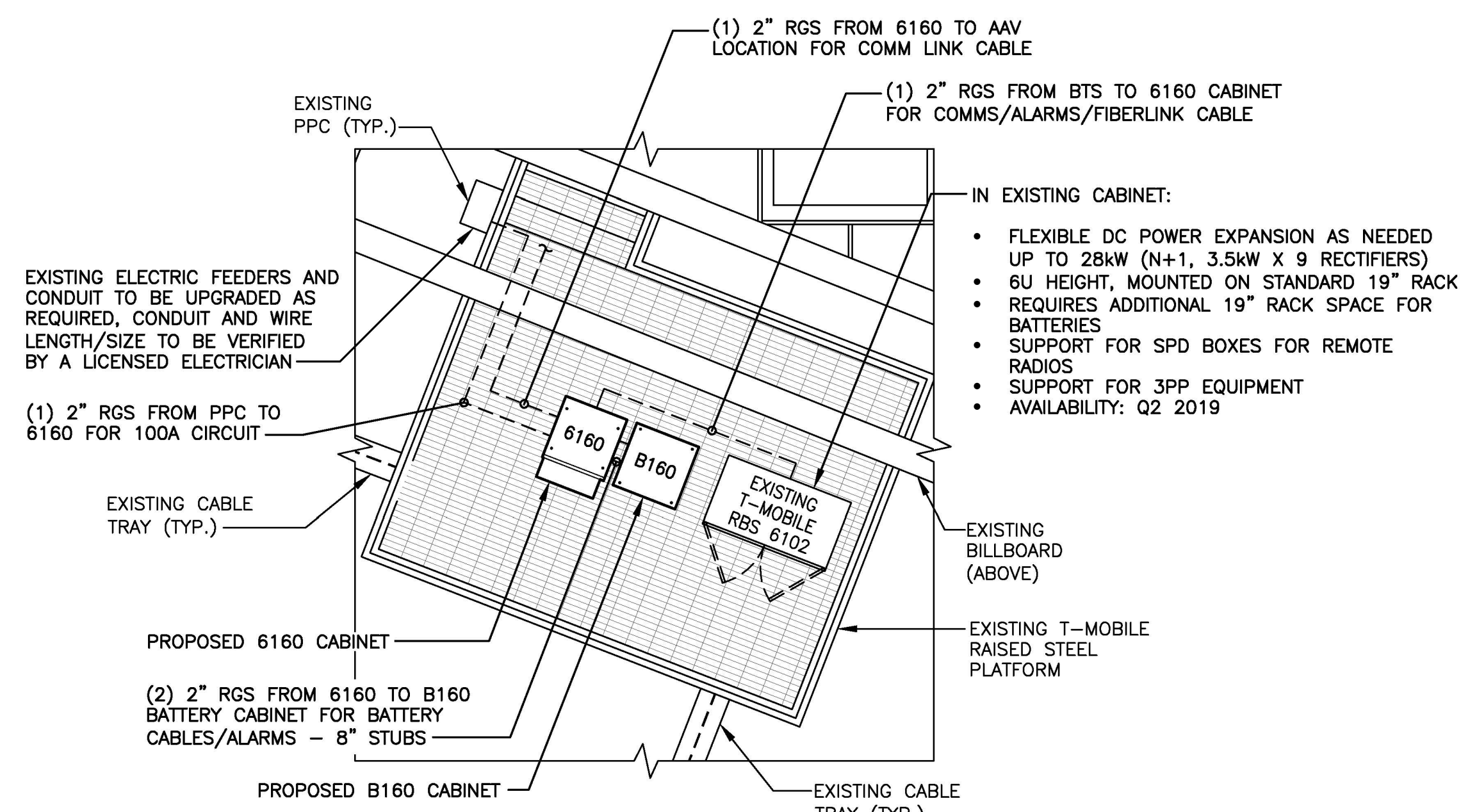

**4**  
E-1 ELECTRICAL SERVICE DIAGRAM  
SCALE: 1/4"=1'-0"

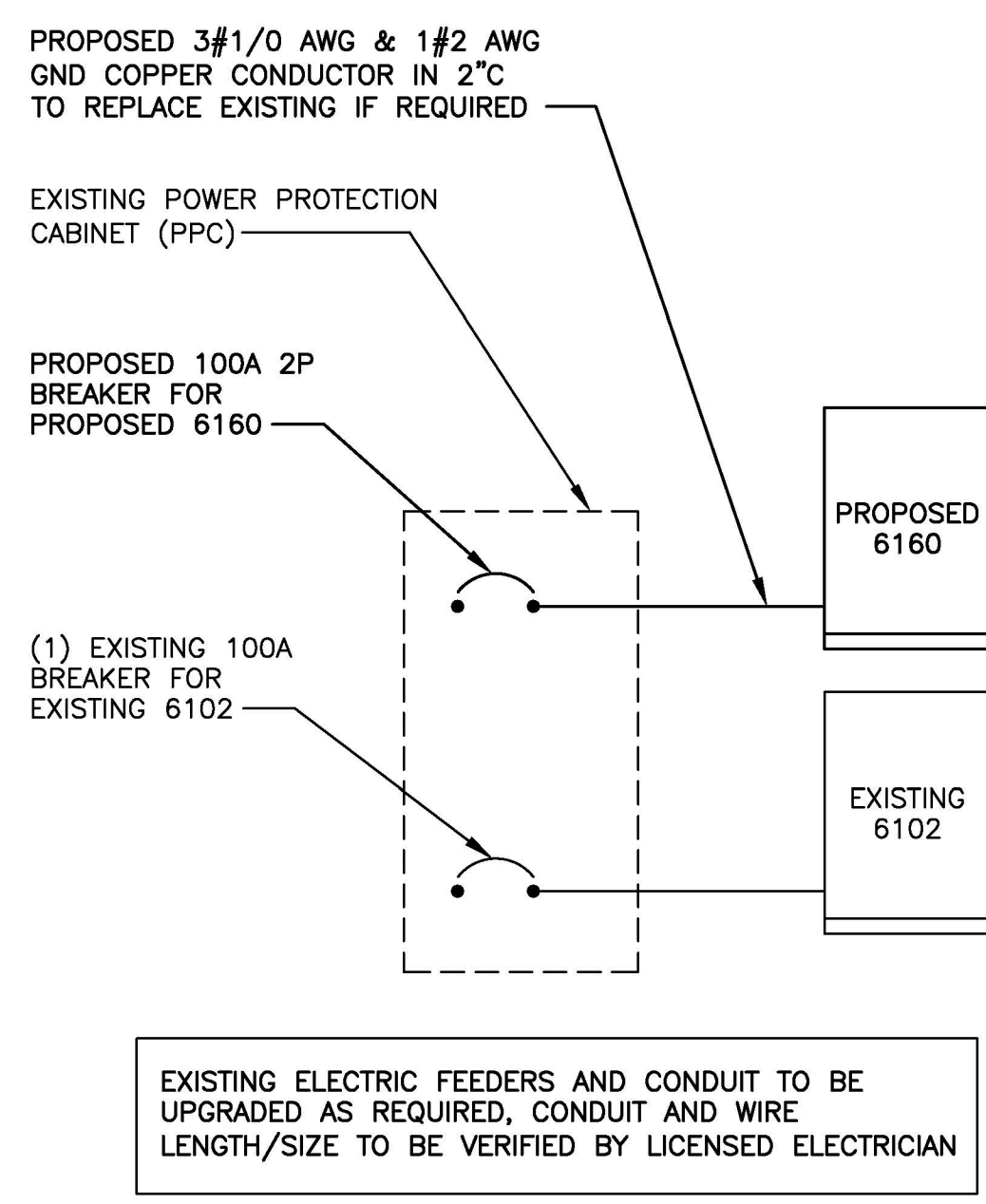
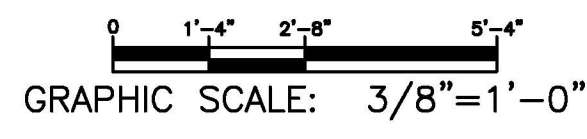

**5**  
E-1 ONE LINE DIAGRAM  
SCALE: 1/4"=1'-0"

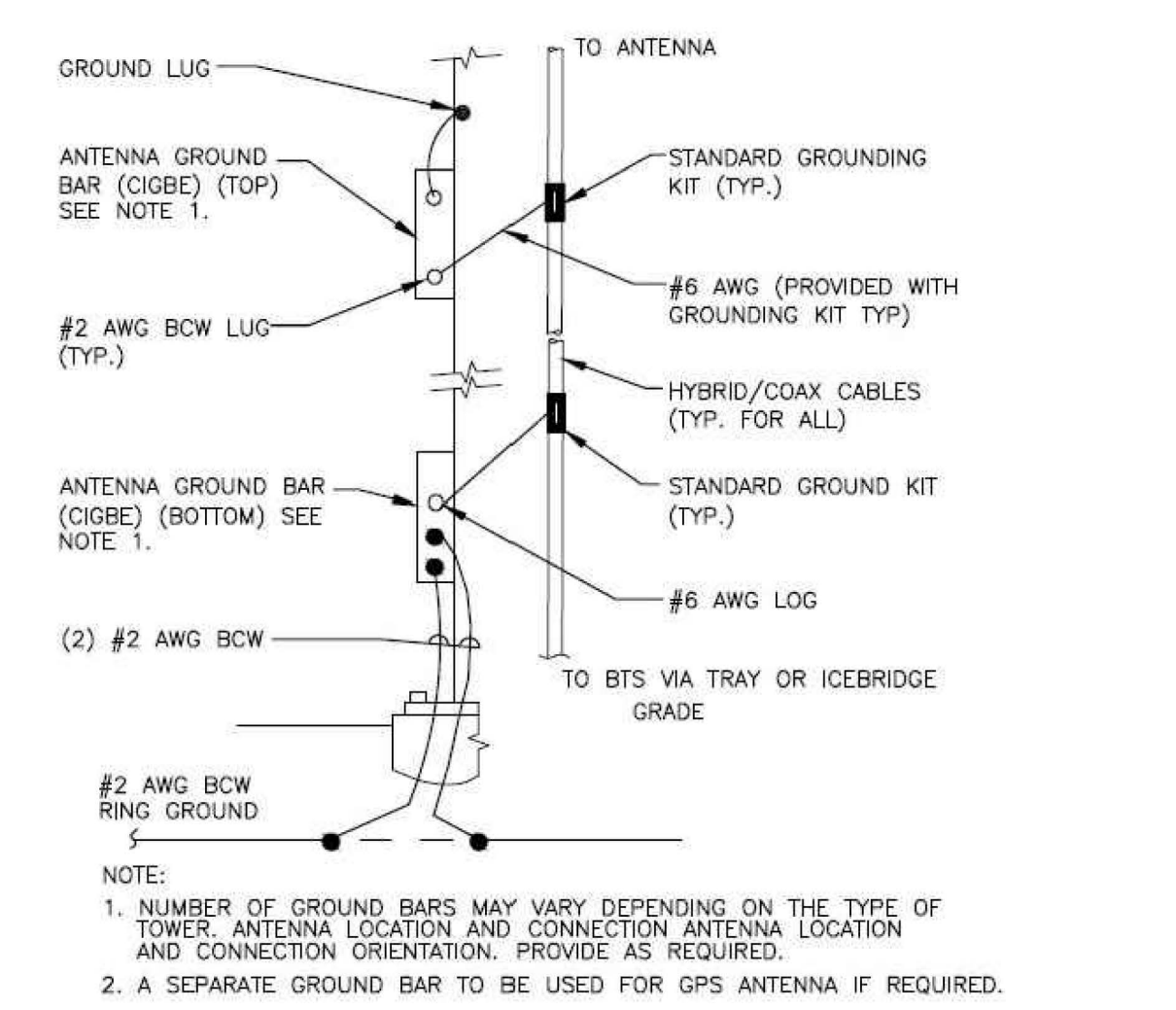

- NOTE:**
- NUMBER OF GROUND BARS MAY VARY DEPENDING ON THE TYPE OF TOWER, ANTENNA LOCATION AND CONNECTION ANTENNA LOCATION AND CONNECTION ORIENTATION. PROVIDE AS REQUIRED.
  - A SEPARATE GROUND BAR TO BE USED FOR GPS ANTENNA IF REQUIRED.

**6**  
E-1 ANTENNA CABLE GROUNDING  
SCALE: N.T.S.

ELECTRICAL LEGEND	
A	AMPERE
V	VOLT
KWH	KILOWATT - HOUR
C	CONDUIT
GRC	GALVANIZED RIGID CONDUIT
G	GROUND
MGB	MASTER GROUND BAR
EGB	EQUIPMENT GROUND BAR
—	GROUND COPPER WIRE, SIZE AS NOTED
—	EXPOSED WIRING
—	COAXIAL CABLE
⊙	5/8"x8" COPPER CLAD STAINLESS STEEL GROUND ROD
⊙	EXOTHERMIC (CAD WELD) OR MECHANICAL (COMPRESSION TYPE) CONNECTION
PPC	POWER PROTECTION CABINET
⊗	OMNI-DIRECTIONAL ELECTRONIC MARKER SYSTEM (EMS) BALL

**COM-EX**  
Consultants  
115 ROUTE 46  
SUITE E39  
MOUNTAIN LAKES, NJ 07046  
PHONE: 862.209.4300  
FAX: 862.209.4301

**T-Mobile**  
T-MOBILE NORTHEAST LLC  
15 COMMERCE WAY, SUITE B  
NORTON, MA 02766  
OFFICE: (508) 286-2700  
FAX: (508) 286-2893

Documents prepared by Com-Ex Consultants, including this document, are to be used only for the specific project and specific use for which they were intended. Any extension of use to any other projects, by owner or by any other party, without the expressed written consent of Com-Ex Consultants, is done unlawfully and at the users own risk. If used in a way other than that specifically intended, user will hold Com-Ex Consultants, harmless from all claims and losses.

SCHEDULE OF REVISIONS		
REV. NO.	DATE	DESCRIPTION OF CHANGES
7		
6		
5		
4		
3		
2	08/27/20	ISSUED AS FINAL
1	07/23/20	REVISED PER RF COMMENTS
0	06/30/20	INITIAL SUBMISSION

DRAWN BY:	WG
CHECKED BY:	CJT
SCALE:	AS NOTED
JOB NO.:	20002-TRN

INFORMATION ON THIS SET OF DRAWINGS IS NOT FOR OFFICIAL USE UNLESS ACCOMPANIED BY THE STAMPED SEAL & SIGNATURE OF A PROFESSIONAL ENGINEER

*Nicholas D. Barile*  
NICHOLAS D. BARILE  
PROFESSIONAL ENGINEER  
STATE OF MASSACHUSETTS  
LICENSE NO. 15164

**NICHOLAS D. BARILE**  
PROFESSIONAL ENGINEER, MA LIC. NO. 15164

**SITE #: 4DE7032A**  
**B0032/1923-1925 MASS AVE**  
**1923-1925 MASSACHUSETTS AVE.**  
**CAMBRIDGE, MA 02140**  
**MIDDLESEX COUNTY**

**DRAWING TITLE:**  
**ELECTRICAL DETAILS & NOTES**

**DRAWING SHEET: 6 OF 7**

**E-1**



**BEFORE**

**EXISTING ANTENNAS**



**PROPOSED ANTENNAS**



**BEFORE**

**EXISTING  
ANTENNAS**



**AFTER**

**PROPOSED  
ANTENNAS**



**BEFORE**

**EXISTING  
ANTENNAS**



**AFTER**

**PROPOSED  
ANTENNAS**



**BEFORE**



**EXISTING  
ANTENNAS**

**AFTER**



**PROPOSED  
ANTENNAS**



Com-Ex Consultants, LLC • 115 Route 46, Suite E39 • Mountain Lakes, NJ • 07046  
Office: 862-209-4300 | Fax: 862-209-4301

**4DE7032A**  
**BO032/1923-1925 Mass Ave**

1923-1925 Massachusetts Ave., Cambridge, MA 02140  
(Middlesex County)

**Equipment Platform Structural Analysis**  
**Anchor Project**

August 27, 2020

<b>Item</b>	<b>Pass/Fail</b>	<b>Capacity</b>
Equipment Platform	Pass	26.0%



**Nicholas D. Barile, P.E.**  
**MA PE License No. 51464**  
Com-Ex Project No. 20002-TRN



Com-Ex Consultants, LLC • 115 Route 46, Suite E39 • Mountain Lakes, NJ • 07046  
Office: 862-209-4300 | Fax: 862-209-4301

## **Executive Summary**

At the request of T-Mobile, Com-Ex Consultants has performed a structural analysis of the equipment platform for the proposed cabinets and ancillary equipment per the *MA STATE BUILDING CODE 780 CMR 8TH ED.*, *ASCE 7*, *ANSI/TIA-222-G*, and *AISC (LRFD14)*. Information pertaining to the equipment platform and connections was obtained from:

- Site Visit notes & photos by Com-Ex Consultants dated 06/16/20.
- T-Mobile Anchor RFDS dated 05/21/20.
- Construction Drawings completed by Com-Ex Consultants dated 08/27/20.

## **Discussion**

Gravity loading change is less than 0.1% of overall gravity loading; therefore, a full rigorous analysis of the structure and its foundation is not required.

## **Conclusions**

Per our analysis, the equipment platform can support proposed loading per the *MA STATE BUILDING CODE 780 CMR 8TH ED.*, *ANSI/TIA-222-G standards*.

## **General Comments**

If there are substantial modifications to be made or the assumptions made in this analysis are not accurate, Com-Ex Consultants should be notified immediately to perform a revised analysis. This report is not a conditions assessment and assumes that good workmanship will be used and systems will be properly maintained.

## **Limitations**

All opinions and conclusions are considered accurate to a reasonable degree of engineering certainty based upon the evidence available at the time of this report. All opinions and conclusions are subject to revision based upon receipt of new or additional/updated information. All services are provided exercising a level of care and diligence equivalent to the standard and care of our profession. No other warranty or guarantee, expressed or implied, is offered. Our services are confidential in nature and we will not release this report to any other party without the client's consent. The use of this engineering work is limited to the express purpose for which it was commissioned and it may not be reused, copied, or distributed for any other purpose without the written consent of Com-Ex Consultants.



Com-Ex Consultants, LLC • 115 Route 46, Suite E39 • Mountain Lakes, NJ • 07046  
Office: 862-209-4300 | Fax: 862-209-4301

**Attachment A**  
**Proposed Equipment Configuration**

**Equipment Platform**

- (1) (N) 6160 Ericsson Cabinet
- (1) (N) B160 Ericsson Battery Cabinet
- (1) (E) RBS6102 Ericsson Cabinet

**Wind Analysis F = qz x Gh x ( EPA) per TIA-222-G**

**qz = 0.00256 x Kz x Kzt x Kd x V<sup>2</sup> x I**

**Kz=2.01 (Z/Zg)<sup>2/α</sup> = 0.850**  
 Zg = 1200 Table 2-4 Exposure B  
 Alpha (α) = 7 Table 2-4  
 Z= 45 ft, 49ft, 53ft  
 Terrain Category I  
**Kzt = (1+KeKt/Kh)<sup>2</sup> = 1.00** for Category I  
 Ke= 1.00 Table 2-4  
 Kt= 0.53 Table 2-5  
**Kh=e<sup>(f \* z/H)</sup> = 0.000** for H=0  
 f= 2.00 Table 2-5  
 H =Height of Crest Surrounding Terrain 0.00 ft  
 Kz = 0.850  
 Kzt = 1.0  
 Kd = 0.95  
 Importance Factor Table 2-3 = I = 1.0 Use Class II  
 Vult = 117 mph  
**Vasd = x Vult x (0.6)<sup>1/2</sup> = 90.6** mph  
**qz = 0.00256 x Kz x Kzt x Kd x V<sup>2</sup> x I = 17.0** psf  
 Gh = 1.00  
**qz Gh = 17.0 psf**

	Equipment Loading	CaAa (sf or sf/lf)	Wind (psf)	Wind Load (lb)	Weight (lb)
FN1	6160 Cabinet	17.59	17.0	298.7	605
FN2	B160	13.65	17.0	231.8	1883
FN3	RBS6102	23.88	17.0	405.5	1331
FN4					
FN5					
FN6					
FN7					
	W6x15	1.00	17.0	17.0	
FT1	6160 Cabinet	13.44	17.0	228.2	605
FT2	B160	13.65	17.0	231.8	1883
FT3	RBS6102	12.86	17.0	218.3	1331
FT4					
FT5					
FT6					
FT7					



Company/Project: SZS Engineering / 20002-TRN

**VersaFrame V8.11 (608.0)**  
(C) Digital Canal Corp.

Engineer: Sam Gonzalez

Date/Time: 08/07/20 16:30:01

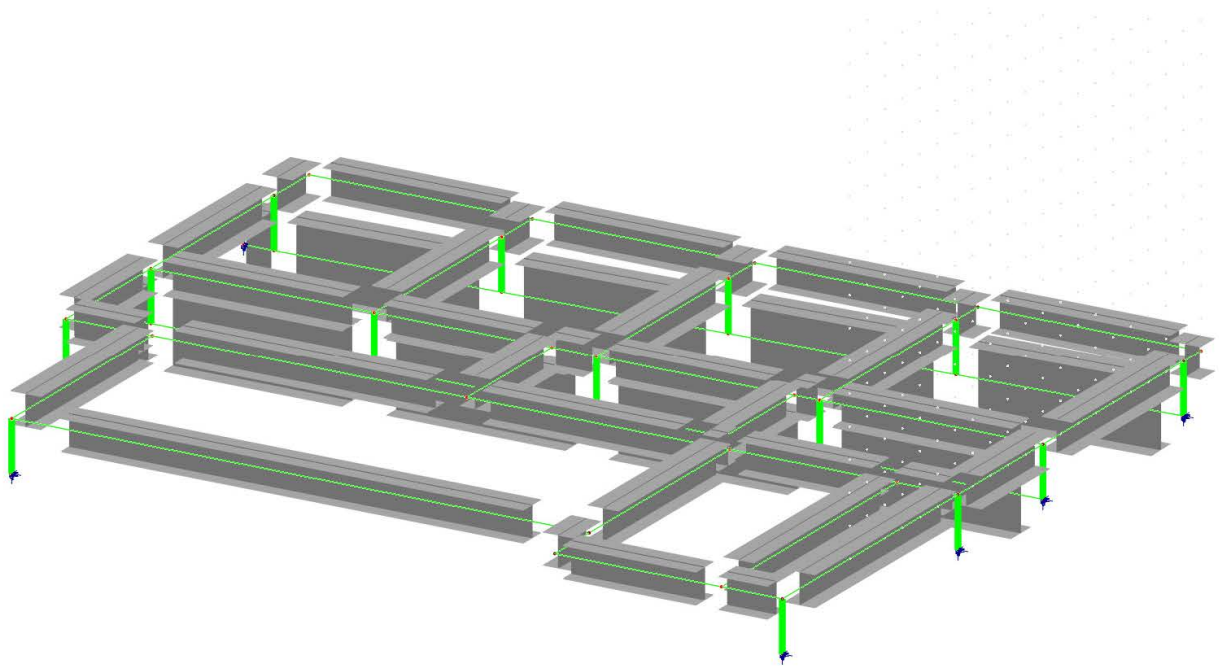

**Note:**

Company/Project: SZS Engineering / 20002-TRN

**VersaFrame V8.11 (608.0)**  
(C) Digital Canal Corp.

Engineer: Sam Gonzalez

Date/Time: 08/07/20 16:29:11

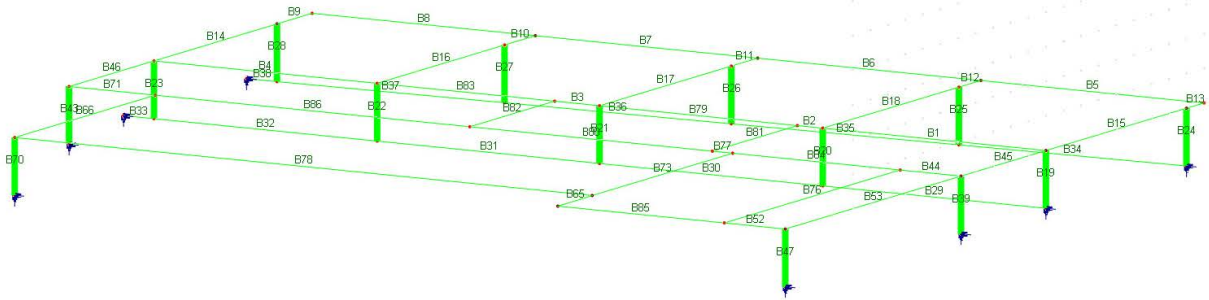

**Note:**

Company/Project: SZS Engineering / 20002-TRN

**VersaFrame V8.11 (608.0)**  
(C) Digital Canal Corp.

Engineer: Sam Gonzalez

Date/Time: 08/07/20 16:28:57

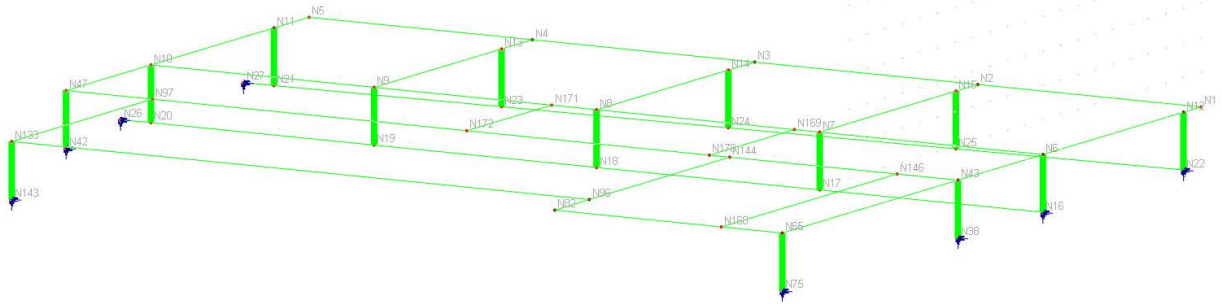

**Note:**

Company/Project: SZS Engineering / 20002-TRN

**VersaFrame V8.11 (608.0)**  
(C) Digital Canal Corp.

Engineer: Sam Gonzalez

Date/Time: 08/07/20 16:28:25

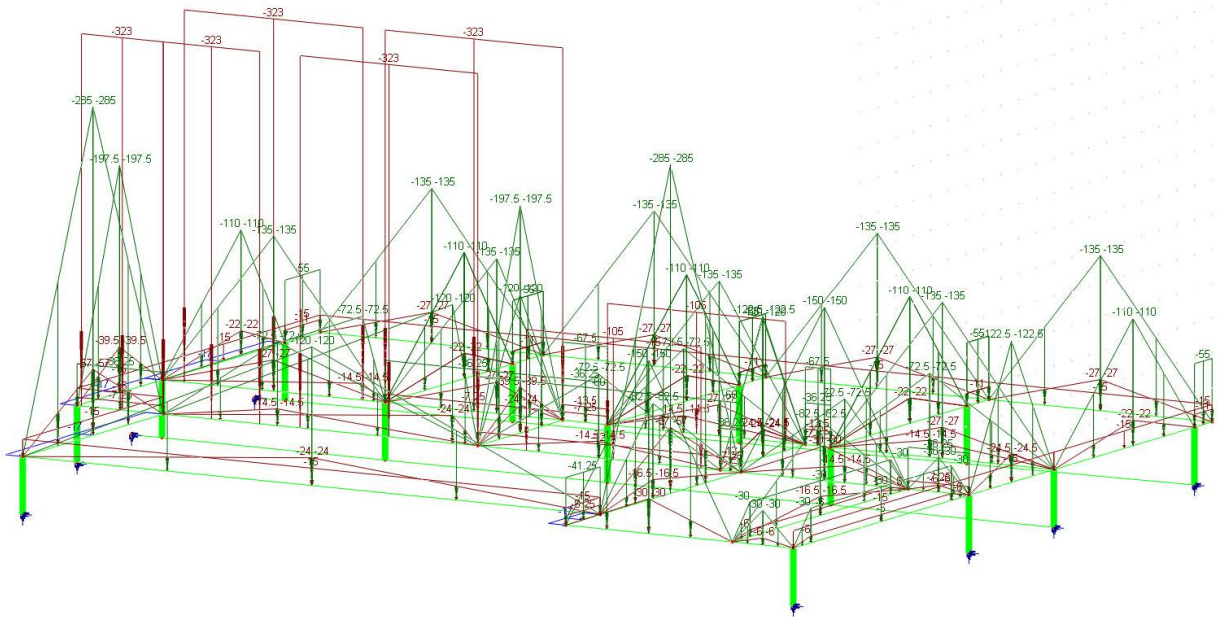

**Note:**

# Steel Check Report

Project: 20002-TRN  
 Description: Equipment Platform  
 Date: 08/07/2020 04:30 PM

Company: SZS Engineering  
 User: Sam Gonzalez  
 Software: Digital Canal VersaFrame

## Code Check Results (LRFD14)

### CRITICAL STRESS SUMMARY

ID	Section Name	Status	Governing Criteria	Stress Ratio	Load Combination	Distance (ft)
1	W6X15	OK	Axial-Bending	0.0480	AISC14-LRFD_LC2c	0.0000
2	W6X15	OK	Axial-Bending	0.0476	AISC14-LRFD_LC2c	0.4167
3	W6X15	OK	Axial-Bending	0.0491	AISC14-LRFD_LC2c	0.7500
4	W6X15	OK	Axial-Bending	0.0534	AISC14-LRFD_LC2c	3.6667
5	W6X15	OK	Axial-Bending	0.0227	AISC14-LRFD_LC2c	2.9333
6	W6X15	OK	Axial-Bending	0.0359	AISC14-LRFD_LC2c	1.8333
7	W6X15	OK	Axial-Bending	0.0393	AISC14-LRFD_LC2c	2.7500
8	W6X15	OK	Axial-Bending	0.0459	AISC14-LRFD_LC2c	3.6667
9	W6X15	OK	Axial-Bending	0.1126	AISC14-LRFD_LC2c	1.0000
10	W6X15	OK	Axial-Bending	0.0725	AISC14-LRFD_LC2c	0.8750
11	W6X15	OK	Axial-Bending	0.0221	AISC14-LRFD_LC2c	0.7500
12	W6X15	OK	Axial-Bending	0.0359	AISC14-LRFD_LC2c	0.6250
13	W6X15	OK	Axial-Bending	0.1037	AISC14-LRFD_LC2c	0.5000
14	W6X15	OK	Axial-Bending	0.0268	AISC14-LRFD_LC2c	0.0000
15	W6X15	OK	Axial-Bending	0.0075	AISC14-LRFD_LC2c	0.0000
16	W6X15	OK	Axial-Bending	0.0416	AISC14-LRFD_LC2c	0.0000
17	W6X15	OK	Shear Y	0.0127	AISC14-LRFD_LC2c	0.0000
18	W6X15	OK	Axial-Bending	0.0454	AISC14-LRFD_LC2c	0.0000
29	W14X30	OK	Axial-Bending	0.0529	AISC14-LRFD_LC2c	3.6667
30	W14X30	OK	Axial-Bending	0.0541	AISC14-LRFD_LC2c	3.6667
31	W14X30	OK	Axial-Bending	0.0524	AISC14-LRFD_LC2c	0.0000
32	W14X30	OK	Axial-Bending	0.0581	AISC14-LRFD_LC2c	0.0000
33	W14X30	OK	Axial-Bending	0.0363	AISC14-LRFD_LC2c	0.0000
34	W14X30	OK	Axial-Bending	0.0386	AISC14-LRFD_LC2c	3.6688
35	W14X30	OK	Axial-Bending	0.0457	AISC14-LRFD_LC2c	3.6688
36	W14X30	OK	Axial-Bending	0.0424	AISC14-LRFD_LC2c	0.0000
37	W14X30	OK	Axial-Bending	0.0467	AISC14-LRFD_LC2c	0.0000
38	W14X30	OK	Axial-Bending	0.0487	AISC14-LRFD_LC2c	0.0000
44	W6X15	OK	Axial-Bending	0.2600	AISC14-LRFD_LC2c	0.0000
45	W6X15	OK	Axial-Bending	0.0205	AISC14-LRFD_LC2c	0.0000
46	W6X15	OK	Axial-Bending	0.0591	AISC14-LRFD_LC2c	2.4167
52	W6X15	OK	Axial-Bending	0.1400	AISC14-LRFD_LC2c	0.0000
53	W6X15	OK	Axial-Bending	0.0461	AISC14-LRFD_LC2c	5.0000
65	W6X15	OK	Axial-Bending	0.1934	AISC14-LRFD_LC2c	1.0000
66	W6X15	OK	Axial-Bending	0.1062	AISC14-LRFD_LC2c	4.0000
71	W6X15	OK	Axial-Bending	0.2550	AISC14-LRFD_LC2c	1.4167
73	W6X15	OK	Axial-Bending	0.1355	AISC14-LRFD_LC2c	0.0000
76	W6X15	OK	Axial-Bending	0.0378	AISC14-LRFD_LC2c	5.0000
77	W6X15	OK	Axial-Bending	0.1083	AISC14-LRFD_LC2c	0.3333
78	W6X15	OK	Axial-Bending	0.1895	AISC14-LRFD_LC2c	9.5000
79	W6X15	OK	Axial-Bending	0.0515	AISC14-LRFD_LC2c	1.7875
80	W6X15	OK	Axial-Bending	0.1745	AISC14-LRFD_LC2c	4.0000
81	W6X15	OK	Axial-Bending	0.0175	AISC14-LRFD_LC1	0.0000
82	W6X15	OK	Shear Y	0.0097	AISC14-LRFD_LC2c	0.0000
83	W6X15	OK	Axial-Bending	0.0585	AISC14-LRFD_LC2c	0.9479
84	W6X15	OK	Axial-Bending	0.1893	AISC14-LRFD_LC2c	0.0000
85	W6X15	OK	Axial-Bending	0.1587	AISC14-LRFD_LC2c	2.7500
86	W6X15	OK	Axial-Bending	0.1740	AISC14-LRFD_LC2c	0.0000

### SELECTED LOAD COMBINATIONS

Load Combination	Code Check	Total	Live	Dependent	Conditional
AISC14-LRFD_LC1	x			-	-
AISC14-LRFD_LC2a	x			-	-

AISC14-LRFD_LC2b	x			-	-
AISC14-LRFD_LC2c	x			-	-
AISC14-LRFD_LC3a	x			-	-
AISC14-LRFD_LC3b	x			-	-
AISC14-LRFD_LC3c	x			-	-
AISC14-LRFD_LC3d	x			-	-
AISC14-LRFD_LC3e	x			-	-
AISC14-LRFD_LC3f	x			-	-
AISC14-LRFD_LC3g	x			-	-
AISC14-LRFD_LC3h	x			-	-
AISC14-LRFD_LC3i	x			-	-
AISC14-LRFD_LC4a	x			-	-
AISC14-LRFD_LC4b	x			-	-
AISC14-LRFD_LC4c	x			-	-
AISC14-LRFD_LC4d	x			-	-
AISC14-LRFD_LC4e	x			-	-
AISC14-LRFD_LC4f	x			-	-
AISC14-LRFD_LC5a	x			-	-
AISC14-LRFD_LC5b	x			-	-
AISC14-LRFD_LC6a	x			-	-
AISC14-LRFD_LC6b	x			-	-
AISC14-LRFD_LC7a	x			-	-
AISC14-LRFD_LC7b	x			-	-

## INPUT Contents

- General:
- Geometry: [[Nodes](#)] [[Supports](#)]
- Loads: [[Point Loads](#)] [[Line Loads](#)]

## OUTPUT Contents

- Nodal: [[Support Reactions](#)]
  - Members:
-

**Nodes**

Units: Coordinates X, Y, Z [in]

No.	X	Y	Z	No.	X	Y	Z
1	0.00	0.00	0.00	2	0.00	0.00	44.00
3	0.00	0.00	88.00	4	0.00	0.00	132.00
5	0.00	0.00	176.00	6	54.00	0.00	0.00
7	54.00	0.00	44.00	8	54.00	0.00	88.00
9	54.00	0.00	132.00	10	54.00	0.00	176.00
11	12.00	0.00	176.00	12	6.00	0.00	0.00
13	10.50	0.00	132.00	14	9.00	0.00	88.00
15	7.50	0.00	44.00	16	54.00	-10.00	0.00
17	54.00	-10.00	44.00	18	54.00	-10.00	88.00
19	54.00	-10.00	132.00	20	54.00	-10.00	176.00
21	12.00	-10.00	176.00	22	6.00	-10.00	0.00
23	10.50	-10.00	132.00	24	9.00	-10.00	88.00
25	7.50	-10.00	44.00	26	54.00	-10.00	182.00
27	12.00	-10.00	182.00	38	83.00	-10.00	0.00
42	83.00	-10.00	176.00	43	83.00	0.00	0.00
47	83.00	0.00	176.00	65	143.00	0.00	0.00
75	143.00	-10.00	0.00	82	143.00	0.00	45.00
96	131.00	0.00	45.00	97	83.00	0.00	159.00
133	131.00	0.00	159.00	143	131.00	-10.00	159.00
144	83.00	0.00	45.00	146	83.00	0.00	12.00
168	143.00	0.00	12.00	169	54.00	0.00	49.00
170	83.00	0.00	49.00	171	54.00	0.00	97.00
172	83.00	0.00	97.00				

**Supports**

Units: Forced Displacements Dx, Dy, Dz [in]; Dox, Doy, Doz [rad]

Node	Flag	Dx	Dy	Dz	Dox	Doy	Doz
16	111011	0.000	0.000	0.000	0.000	0.000	0.000
22	111011	0.000	0.000	0.000	0.000	0.000	0.000
26	111011	0.000	0.000	0.000	0.000	0.000	0.000
27	111011	0.000	0.000	0.000	0.000	0.000	0.000
38	111011	0.000	0.000	0.000	0.000	0.000	0.000
42	111011	0.000	0.000	0.000	0.000	0.000	0.000
75	111011	0.000	0.000	0.000	0.000	0.000	0.000
143	111011	0.000	0.000	0.000	0.000	0.000	0.000

**Point Loads**

Units: Force [lb]; Moment [lb-in]; Coord-Sys: Local=0, Global=1;  
 Direction: 0=X, 1=Y, 2=Z, 3=OX, 4=OY, 5=OZ

**Line Loads**

Units: Force [lb/ft]; Coord-Sys: Local=0, Global=1; Direction: 0=X, 1=Y, 2=Z

\*\*\*\*\* LOAD CASE - [ Dead ]\*\*\*\*\*

Member	Coord-Sys	Direction	Value1	Value2	Distance1	Distance2
1	1	1	-14.500	0.000	0.556818	1
1	1	1	0.000	-14.500	0	0.556818
1	1	1	-27.000	0.000	0.5	1
1	1	1	0.000	-27.000	0	0.5
2	1	1	-13.500	-13.500	0	1
2	1	1	-7.250	-7.250	0	1
3	1	1	-7.250	-7.250	0	1
3	1	1	-13.500	-13.500	0	1
4	1	1	-27.000	0.000	0.5	1
4	1	1	-323.000	-323.000	0.1	0.9
4	1	1	-14.500	0.000	0.102273	1
4	1	1	0.000	-14.500	0	0.102273
4	1	1	0.000	-27.000	0	0.5



5	1	1	-15.000	-15.000	0	1
5	1	1	0.000	-27.000	0	0.5
5	1	1	-27.000	0.000	0.5	1
6	1	1	-15.000	-15.000	0	1
6	1	1	0.000	-27.000	0	0.5
6	1	1	-27.000	0.000	0.5	1
7	1	1	-15.000	-15.000	0	1
7	1	1	0.000	-27.000	0	0.5
7	1	1	-27.000	0.000	0.5	1
8	1	1	-15.000	-15.000	0	1
8	1	1	0.000	-27.000	0	0.5
8	1	1	-27.000	0.000	0.5	1
9	1	1	-15.000	-15.000	0	1
9	1	1	-11.000	-11.000	0	1
10	1	1	-11.000	-11.000	0	1
10	1	1	-11.000	-11.000	0	1
11	1	1	-11.000	-11.000	0	1
11	1	1	-11.000	-11.000	0	1
12	1	1	-11.000	-11.000	0	1
12	1	1	-11.000	-11.000	0	1
13	1	1	-15.000	-15.000	0	1
13	1	1	-11.000	-11.000	0	1
14	1	1	-15.000	-15.000	0	1
14	1	1	0.000	-22.000	0	0.357143
14	1	1	-22.000	0.000	0.357143	1
15	1	1	-15.000	-15.000	0	1
15	1	1	0.000	-22.000	0	0.4375
15	1	1	-22.000	0.000	0.4375	1
16	1	1	0.000	-22.000	0	0.37931
16	1	1	-22.000	0.000	0.37931	1
16	1	1	0.000	-22.000	0	0.37931
16	1	1	-22.000	0.000	0.37931	1
17	1	1	0.000	-22.000	0	0.4
17	1	1	-22.000	0.000	0.4	1
17	1	1	0.000	-22.000	0	0.4
17	1	1	-22.000	0.000	0.4	1
18	1	1	-22.000	0.000	0.419355	1
18	1	1	-22.000	0.000	0.419355	1
18	1	1	0.000	-22.000	0	0.419355
18	1	1	0.000	-22.000	0	0.419355
44	1	1	-6.000	0.000	0.5	1
44	1	1	0.000	-6.000	0	0.5
44	1	1	-7.250	-7.250	0	1
45	1	1	0.000	-24.500	0	0.5
45	1	1	-15.000	-15.000	0	1
45	1	1	-24.500	0.000	0.5	1
46	1	1	-15.000	-15.000	0	1
46	1	1	0.000	-39.500	0	0.5
46	1	1	-39.500	0.000	0.5	1
52	1	1	-6.000	0.000	0.5	1
52	1	1	0.000	-6.000	0	0.5
53	1	1	-15.000	-15.000	0	1
53	1	1	-6.000	0.000	0.9	1
53	1	1	-6.000	-6.000	0.1	0.9
53	1	1	0.000	-6.000	0	0.1
65	1	1	-15.000	-15.000	0	1
65	1	1	-8.250	-8.250	0	1
66	1	1	-15.000	-15.000	0	1
66	1	1	0.000	-57.000	0	0.5
66	1	1	-57.000	0.000	0.5	1
71	1	1	-323.000	-323.000	0	0.95
71	1	1	-15.000	-15.000	0	1
71	1	1	-7.250	-7.250	0	1
73	1	1	-57.000	0.000	0.5	1
73	1	1	0.000	-16.500	0	0.375
73	1	1	-16.500	0.000	0.375	1
73	1	1	0.000	-57.000	0	0.5
76	1	1	-6.000	0.000	0.9	1
76	1	1	0.000	-16.500	0	0.5
76	1	1	-16.500	0.000	0.5	1
76	1	1	0.000	-6.000	0	0.1

	1	1	-6.000	-6.000	0.1	0.9
77	1	1	-7.250	-7.250	0	1
77	1	1	-12.000	-12.000	0	1
78	1	1	-15.000	-15.000	0	1
78	1	1	0.000	-24.000	0	0.5
78	1	1	-24.000	0.000	0.5	1
79	1	1	-105.000	-105.000	0.1	1
79	1	1	0.000	-27.000	0	0.435897
79	1	1	-27.000	0.000	0.435897	1
79	1	1	-14.500	0.000	0.615385	1
79	1	1	0.000	-14.500	0	0.615385
80	1	1	0.000	-14.500	0	0.5
80	1	1	-105.000	-105.000	0.08	0.8
80	1	1	-14.500	0.000	0.5	1
80	1	1	-12.000	-12.000	0	1
81	1	1	-24.000	0.000	0.5	1
81	1	1	0.000	-24.000	0	0.5
81	1	1	-24.500	0.000	0.5	1
81	1	1	0.000	-24.500	0	0.5
82	1	1	0.000	-24.000	0	0.5
82	1	1	0.000	-39.500	0	0.5
82	1	1	-39.500	0.000	0.5	1
82	1	1	-24.000	0.000	0.5	1
83	1	1	0.000	-27.000	0	0.371429
83	1	1	-7.250	-7.250	0	1
83	1	1	-323.000	-323.000	0	1
83	1	1	-27.000	0.000	0.371429	1
84	1	1	0.000	-14.500	0	0.378788
84	1	1	-14.500	0.000	0.378788	1
84	1	1	0.000	-30.000	0	0.5
84	1	1	-30.000	0.000	0.5	1
85	1	1	-30.000	0.000	0.5	1
85	1	1	0.000	-30.000	0	0.5
86	1	1	-323.000	-323.000	0	0.565
86	1	1	0.000	-14.500	0	0.637097
86	1	1	-14.500	0.000	0.637097	1
86	1	1	-323.000	-323.000	0.6935	1
86	1	1	0.000	-24.000	0	0.0806452
86	1	1	-24.000	0.000	0.0806452	1

\*\*\*\*\* LOAD CASE - [ Wind ]\*\*\*\*\*

Member	Coord-Sys	Direction	Value1	Value2	Distance1	Distance2
14	1	2	-17.000	-17.000	0	1
46	1	2	-17.000	-17.000	0	1
65	1	2	-17.000	-17.000	0	1
66	1	2	-17.000	-17.000	0	1

\*\*\*\*\* LOAD CASE - [ Live ]\*\*\*\*\*

Member	Coord-Sys	Direction	Value1	Value2	Distance1	Distance2
1	1	1	-72.500	0.000	0.556818	1
1	1	1	0.000	-72.500	0	0.556818
1	1	1	0.000	-135.000	0	0.5
1	1	1	-135.000	0.000	0.5	1
2	1	1	-67.500	-67.500	0	1
2	1	1	-36.250	-36.250	0	1
3	1	1	-36.250	-36.250	0	1
3	1	1	-67.500	-67.500	0	1
4	1	1	-135.000	0.000	0.5	1
4	1	1	0.000	-135.000	0	0.5
4	1	1	0.000	-72.500	0	0.102273
4	1	1	-72.500	0.000	0.102273	1
5	1	1	-135.000	0.000	0.5	1
5	1	1	0.000	-135.000	0	0.5
6	1	1	0.000	-135.000	0	0.5
6	1	1	-135.000	0.000	0.5	1
7	1	1	0.000	-135.000	0	0.5
7	1	1	-135.000	0.000	0.5	1
8	1	1	-135.000	0.000	0.5	1
8	1	1	0.000	-135.000	0	0.5
9	1	1	-55.000	-55.000	0	1
10	1	1	-55.000	-55.000	0	1

10	1	1	-55.000	-55.000	0	1
11	1	1	-55.000	-55.000	0	1
11	1	1	-55.000	-55.000	0	1
12	1	1	-55.000	-55.000	0	1
12	1	1	-55.000	-55.000	0	1
13	1	1	-55.000	-55.000	0	1
14	1	1	0.000	-110.000	0	0.357143
14	1	1	-110.000	0.000	0.357143	1
15	1	1	0.000	-110.000	0	0.4375
15	1	1	-110.000	0.000	0.4375	1
16	1	1	0.000	-110.000	0	0.37931
16	1	1	0.000	-110.000	0	0.37931
16	1	1	-110.000	0.000	0.37931	1
16	1	1	-110.000	0.000	0.37931	1
17	1	1	0.000	-110.000	0	0.4
17	1	1	-110.000	0.000	0.4	1
17	1	1	-110.000	0.000	0.4	1
17	1	1	0.000	-110.000	0	0.4
18	1	1	0.000	-110.000	0	0.419355
18	1	1	-110.000	0.000	0.419355	1
18	1	1	-110.000	0.000	0.419355	1
18	1	1	0.000	-110.000	0	0.419355
44	1	1	-36.250	-36.250	0	1
44	1	1	0.000	-30.000	0	0.5
44	1	1	-30.000	0.000	0.5	1
45	1	1	0.000	-122.500	0	0.5
45	1	1	-122.500	0.000	0.5	1
46	1	1	-197.500	0.000	0.5	1
46	1	1	0.000	-197.500	0	0.5
52	1	1	0.000	-30.000	0	0.5
52	1	1	-30.000	0.000	0.5	1
53	1	1	0.000	-30.000	0	0.1
53	1	1	-30.000	-30.000	0.1	0.9
53	1	1	-30.000	0.000	0.9	1
65	1	1	-41.250	-41.250	0	1
66	1	1	0.000	-285.000	0	0.5
66	1	1	-285.000	0.000	0.5	1
71	1	1	-36.250	-36.250	0	1
73	1	1	0.000	-82.500	0	0.375
73	1	1	-82.500	0.000	0.375	1
73	1	1	0.000	-285.000	0	0.5
73	1	1	-285.000	0.000	0.5	1
76	1	1	0.000	-30.000	0	0.1
76	1	1	-30.000	-30.000	0.1	0.9
76	1	1	-30.000	0.000	0.9	1
76	1	1	0.000	-82.500	0	0.5
76	1	1	-82.500	0.000	0.5	1
77	1	1	-36.250	-36.250	0	1
77	1	1	-60.000	-60.000	0	1
78	1	1	0.000	-120.000	0	0.5
78	1	1	-120.000	0.000	0.5	1
79	1	1	0.000	-72.500	0	0.615385
79	1	1	-72.500	0.000	0.615385	1
79	1	1	-135.000	0.000	0.435897	1
79	1	1	0.000	-135.000	0	0.435897
80	1	1	0.000	-72.500	0	0.5
80	1	1	-72.500	0.000	0.5	1
80	1	1	-60.000	-60.000	0	1
81	1	1	-122.500	0.000	0.5	1
81	1	1	0.000	-122.500	0	0.5
81	1	1	0.000	-120.000	0	0.5
81	1	1	-120.000	0.000	0.5	1
82	1	1	-197.500	0.000	0.5	1
82	1	1	0.000	-120.000	0	0.5
82	1	1	-120.000	0.000	0.5	1
82	1	1	0.000	-197.500	0	0.5
83	1	1	-135.000	0.000	0.371429	1
83	1	1	0.000	-135.000	0	0.371429
83	1	1	-36.250	-36.250	0	1
84	1	1	0.000	-72.500	0	0.378788
84	1	1	0.000	-150.000	0	0.5

	1	1	-72.500	0.000	0.378788	1
84	1	1	-150.000	0.000	0.5	1
85	1	1	0.000	-150.000	0	0.5
85	1	1	-150.000	0.000	0.5	1
86	1	1	0.000	-72.500	0	0.637097
86	1	1	-72.500	0.000	0.637097	1
86	1	1	0.000	-120.000	0	0.0806452
86	1	1	-120.000	0.000	0.0806452	1

**Support Reactions**

Units: Force Reactions Rx, Ry, Rz [lb]; Moment Reactions Rox, Roy, Roz [lb-in]

Load Combination 2: AISC14-LRFD LC1

Node	Rx	Ry	Rz	Rox	Roy	Roz
16	176.861	2016.445	4788.544	0.000	3372.302	-944.692
22	52.770	1244.179	1448.104	0.000	11235.527	1000.926
26	-816.854	2155.161	-4036.209	0.000	-328.229	-7.075
27	-5.282	1307.861	-1507.971	0.000	-5922.114	6.217
38	-277.154	1635.348	5262.563	0.000	-80.333	3667.091
42	853.144	3348.426	-6017.591	0.000	-4768.792	-21092.636
75	81.527	644.303	1713.891	0.000	2661.856	-2071.272
143	-65.012	1047.276	-1651.331	0.000	958.105	-21264.586

Load Combination 3: AISC14-LRFD LC2a

Node	Rx	Ry	Rz	Rox	Roy	Roz
16	399.160	3893.847	7275.153	0.000	14980.610	-2877.091
22	168.899	3026.183	3633.844	0.000	26863.559	2347.583
26	-1288.959	3387.401	-7205.953	0.000	827.766	-20.945
27	-399.871	2993.124	-3801.060	0.000	-11852.926	4.143
38	-895.744	3881.613	10427.805	0.000	10486.499	10221.150
42	1653.876	5024.707	-10350.579	0.000	-2680.437	-36841.584
75	199.380	1905.154	5568.134	0.000	9019.313	-4234.821
143	163.259	2559.494	-5547.344	0.000	-1440.626	-39091.892

Load Combination 4: AISC14-LRFD LC2b

Node	Rx	Ry	Rz	Rox	Roy	Roz
16	399.160	3893.847	7275.153	0.000	14980.610	-2877.091
22	168.899	3026.183	3633.844	0.000	26863.559	2347.583
26	-1288.959	3387.401	-7205.953	0.000	827.766	-20.945
27	-399.871	2993.124	-3801.060	0.000	-11852.926	4.143
38	-895.744	3881.613	10427.805	0.000	10486.499	10221.150
42	1653.876	5024.707	-10350.579	0.000	-2680.437	-36841.584
75	199.380	1905.154	5568.134	0.000	9019.313	-4234.821
143	163.259	2559.494	-5547.344	0.000	-1440.626	-39091.892

Load Combination 5: AISC14-LRFD LC2c

Node	Rx	Ry	Rz	Rox	Roy	Roz
16	399.160	3893.847	7275.153	0.000	14980.610	-2877.091
22	168.899	3026.183	3633.844	0.000	26863.559	2347.583
26	-1288.959	3387.401	-7205.953	0.000	827.766	-20.945
27	-399.871	2993.124	-3801.060	0.000	-11852.926	4.143
38	-895.744	3881.613	10427.805	0.000	10486.499	10221.150
42	1653.876	5024.707	-10350.579	0.000	-2680.437	-36841.584
75	199.380	1905.154	5568.134	0.000	9019.313	-4234.821
143	163.259	2559.494	-5547.344	0.000	-1440.626	-39091.892

Load Combination 6: AISC14-LRFD LC3a

Node	Rx	Ry	Rz	Rox	Roy	Roz
16	305.569	3082.246	6086.976	0.000	10409.181	-2099.530
22	121.599	2291.025	2736.410	0.000	20374.983	1789.985
26	-1067.931	2809.968	-5800.453	0.000	416.249	-15.367
27	-251.753	2291.041	-2860.001	0.000	-9303.698	4.581
38	-646.393	2951.684	8201.850	0.000	6485.428	7541.470
42	1306.772	4216.822	-8396.488	0.000	-3204.314	-29792.473
75	150.741	1397.703	4019.047	0.000	6458.950	-3311.900
143	81.396	1936.035	-3987.342	0.000	-590.152	-31255.437

Load Combination 7: AISC14-LRFD LC3b

Node	Rx	Ry	Rz	Rox	Roy	Roz
16	305.569	3082.246	6086.976	0.000	10409.181	-2099.530
22	121.599	2291.025	2736.410	0.000	20374.983	1789.985
26	-1067.931	2809.968	-5800.453	0.000	416.249	-15.367
27	-251.753	2291.041	-2860.001	0.000	-9303.698	4.581
38	-646.393	2951.684	8201.850	0.000	6485.428	7541.470
42	1306.772	4216.822	-8396.488	0.000	-3204.314	-29792.473
75	150.741	1397.703	4019.047	0.000	6458.950	-3311.900
143	81.396	1936.035	-3987.342	0.000	-590.152	-31255.437

Load Combination 8: AISC14-LRFD LC3c

Node	Rx	Ry	Rz	Rox	Roy	Roz
16	305.569	3082.246	6086.976	0.000	10409.181	-2099.530
22	121.599	2291.025	2736.410	0.000	20374.983	1789.985
26	-1067.931	2809.968	-5800.453	0.000	416.249	-15.367
27	-251.753	2291.041	-2860.001	0.000	-9303.698	4.581
38	-646.393	2951.684	8201.850	0.000	6485.428	7541.470
42	1306.772	4216.822	-8396.488	0.000	-3204.314	-29792.473
75	150.741	1397.703	4019.047	0.000	6458.950	-3311.900
143	81.396	1936.035	-3987.342	0.000	-590.152	-31255.437

Load Combination 9: AISC14-LRFD LC3d

Node	Rx	Ry	Rz	Rox	Roy	Roz
16	151.989	1730.345	4117.326	0.000	2850.383	-811.133
22	45.206	1067.227	1243.636	0.000	9639.233	858.710
26	-701.545	1844.323	-3436.297	0.000	-272.860	-6.111
27	-5.950	1119.953	-1280.377	0.000	-5131.618	5.419
38	-237.345	1402.888	4515.909	0.000	-134.780	3140.984
42	725.734	2869.677	-5144.800	0.000	-4048.845	-18044.567
75	70.795	553.531	1473.972	0.000	2263.738	-1784.599
143	-48.884	896.913	-1396.578	0.000	953.640	-18334.261

Load Combination 10: AISC14-LRFD LC3e

Node	Rx	Ry	Rz	Rox	Roy	Roz
16	151.989	1730.345	4117.326	0.000	2850.383	-811.133
22	45.206	1067.227	1243.636	0.000	9639.233	858.710
26	-701.545	1844.323	-3436.297	0.000	-272.860	-6.111
27	-5.950	1119.953	-1280.377	0.000	-5131.618	5.419
38	-237.345	1402.888	4515.909	0.000	-134.780	3140.984
42	725.734	2869.677	-5144.800	0.000	-4048.845	-18044.567
75	70.795	553.531	1473.972	0.000	2263.738	-1784.599
143	-48.884	896.913	-1396.578	0.000	953.640	-18334.261

Load Combination 11: AISC14-LRFD LC3f

Node	Rx	Ry	Rz	Rox	Roy	Roz
16	151.989	1730.345	4117.326	0.000	2850.383	-811.133
22	45.206	1067.227	1243.636	0.000	9639.233	858.710
26	-701.545	1844.323	-3436.297	0.000	-272.860	-6.111
27	-5.950	1119.953	-1280.377	0.000	-5131.618	5.419
38	-237.345	1402.888	4515.909	0.000	-134.780	3140.984
42	725.734	2869.677	-5144.800	0.000	-4048.845	-18044.567
75	70.795	553.531	1473.972	0.000	2263.738	-1784.599
143	-48.884	896.913	-1396.578	0.000	953.640	-18334.261

Load Combination 12: AISC14-LRFD LC3g

Node	Rx	Ry	Rz	Rox	Roy	Roz
16	151.065	1726.430	4090.759	0.000	2921.814	-808.101
22	45.070	1065.615	1238.778	0.000	9615.432	857.100
26	-698.414	1850.497	-3482.516	0.000	-285.984	-6.024
27	-3.231	1122.077	-1304.609	0.000	-5018.108	5.237
38	-237.345	1400.610	4499.807	0.000	-9.889	3141.132
42	736.271	2870.637	-5164.648	0.000	-4116.840	-18105.482
75	68.911	550.969	1462.239	0.000	2294.806	-1765.612
143	-62.327	898.021	-1432.604	0.000	687.425	-18101.144

Load Combination 13: AISC14-LRFD LC3h

Node	Rx	Ry	Rz	Rox	Roy	Roz
16	151.065	1726.430	4090.759	0.000	2921.814	-808.101

22	45.070	1065.615	1238.778	0.000	9615.432	857.100
26	-698.414	1850.497	-3482.516	0.000	-285.984	-6.024
27	-3.231	1122.077	-1304.609	0.000	-5018.108	5.237
38	-237.345	1400.610	4499.807	0.000	-9.889	3141.132
42	736.271	2870.637	-5164.648	0.000	-4116.840	-18105.482
75	68.911	550.969	1462.239	0.000	2294.806	-1765.612
143	-62.327	898.021	-1432.604	0.000	687.425	-18101.144

Load Combination 14: AISC14-LRFD LC3i

Node	Rx	Ry	Rz	Rox	Roy	Roz
16	151.065	1726.430	4090.759	0.000	2921.814	-808.101
22	45.070	1065.615	1238.778	0.000	9615.432	857.100
26	-698.414	1850.497	-3482.516	0.000	-285.984	-6.024
27	-3.231	1122.077	-1304.609	0.000	-5018.108	5.237
38	-237.345	1400.610	4499.807	0.000	-9.889	3141.132
42	736.271	2870.637	-5164.648	0.000	-4116.840	-18105.482
75	68.911	550.969	1462.239	0.000	2294.806	-1765.612
143	-62.327	898.021	-1432.604	0.000	687.425	-18101.144

Load Combination 15: AISC14-LRFD LC4a

Node	Rx	Ry	Rz	Rox	Roy	Roz
16	306.490	3086.163	6113.565	0.000	10337.646	-2102.550
22	121.732	2292.636	2741.271	0.000	20398.765	1791.618
26	-1071.069	2803.790	-5754.230	0.000	429.307	-15.454
27	-254.470	2288.916	-2835.772	0.000	-9417.228	4.764
38	-646.387	2953.961	8218.014	0.000	6360.205	7541.257
42	1296.223	4215.856	-8376.705	0.000	-3136.408	-29731.480
75	152.630	1400.259	4030.734	0.000	6427.626	-3330.941
143	94.850	1934.941	-3951.294	0.000	-324.064	-31488.978

Load Combination 16: AISC14-LRFD LC4b

Node	Rx	Ry	Rz	Rox	Roy	Roz
16	306.490	3086.163	6113.565	0.000	10337.646	-2102.550
22	121.732	2292.636	2741.271	0.000	20398.765	1791.618
26	-1071.069	2803.790	-5754.230	0.000	429.307	-15.454
27	-254.470	2288.916	-2835.772	0.000	-9417.228	4.764
38	-646.387	2953.961	8218.014	0.000	6360.205	7541.257
42	1296.223	4215.856	-8376.705	0.000	-3136.408	-29731.480
75	152.630	1400.259	4030.734	0.000	6427.626	-3330.941
143	94.850	1934.941	-3951.294	0.000	-324.064	-31488.978

Load Combination 17: AISC14-LRFD LC4c

Node	Rx	Ry	Rz	Rox	Roy	Roz
16	306.490	3086.163	6113.565	0.000	10337.646	-2102.550
22	121.732	2292.636	2741.271	0.000	20398.765	1791.618
26	-1071.069	2803.790	-5754.230	0.000	429.307	-15.454
27	-254.470	2288.916	-2835.772	0.000	-9417.228	4.764
38	-646.387	2953.961	8218.014	0.000	6360.205	7541.257
42	1296.223	4215.856	-8376.705	0.000	-3136.408	-29731.480
75	152.630	1400.259	4030.734	0.000	6427.626	-3330.941
143	94.850	1934.941	-3951.294	0.000	-324.064	-31488.978

Load Combination 18: AISC14-LRFD LC4d

Node	Rx	Ry	Rz	Rox	Roy	Roz
16	304.648	3078.328	6060.387	0.000	10480.714	-2096.511
22	121.466	2289.414	2731.550	0.000	20351.200	1788.352
26	-1064.794	2816.145	-5846.676	0.000	403.190	-15.280
27	-249.036	2293.165	-2884.229	0.000	-9190.167	4.399
38	-646.399	2949.407	8185.686	0.000	6610.647	7541.681
42	1317.321	4217.787	-8416.271	0.000	-3272.220	-29853.466
75	148.852	1395.147	4007.359	0.000	6490.271	-3292.859
143	67.942	1937.129	-4023.389	0.000	-856.240	-31021.898

Load Combination 19: AISC14-LRFD LC4e

Node	Rx	Ry	Rz	Rox	Roy	Roz
16	304.648	3078.328	6060.387	0.000	10480.714	-2096.511
22	121.466	2289.414	2731.550	0.000	20351.200	1788.352
26	-1064.794	2816.145	-5846.676	0.000	403.190	-15.280
27	-249.036	2293.165	-2884.229	0.000	-9190.167	4.399

38	-646.399	2949.407	8185.686	0.000	6610.647	7541.681
42	1317.321	4217.787	-8416.271	0.000	-3272.220	-29853.466
75	148.852	1395.147	4007.359	0.000	6490.271	-3292.859
143	67.942	1937.129	-4023.389	0.000	-856.240	-31021.898

Load Combination 20: AISC14-LRFD LC4f

Node	Rx	Ry	Rz	Rox	Roy	Roz
16	304.648	3078.328	6060.387	0.000	10480.714	-2096.511
22	121.466	2289.414	2731.550	0.000	20351.200	1788.352
26	-1064.794	2816.145	-5846.676	0.000	403.190	-15.280
27	-249.036	2293.165	-2884.229	0.000	-9190.167	4.399
38	-646.399	2949.407	8185.686	0.000	6610.647	7541.681
42	1317.321	4217.787	-8416.271	0.000	-3272.220	-29853.466
75	148.852	1395.147	4007.359	0.000	6490.271	-3292.859
143	67.942	1937.129	-4023.389	0.000	-856.240	-31021.898

Load Combination 21: AISC14-LRFD LC5a

Node	Rx	Ry	Rz	Rox	Roy	Roz
16	305.569	3082.246	6086.976	0.000	10409.181	-2099.530
22	121.599	2291.025	2736.410	0.000	20374.983	1789.985
26	-1067.931	2809.968	-5800.453	0.000	416.249	-15.367
27	-251.753	2291.041	-2860.001	0.000	-9303.698	4.581
38	-646.393	2951.684	8201.850	0.000	6485.428	7541.470
42	1306.772	4216.822	-8396.488	0.000	-3204.314	-29792.473
75	150.741	1397.703	4019.047	0.000	6458.950	-3311.900
143	81.396	1936.035	-3987.342	0.000	-590.152	-31255.437

Load Combination 22: AISC14-LRFD LC5b

Node	Rx	Ry	Rz	Rox	Roy	Roz
16	305.569	3082.246	6086.976	0.000	10409.181	-2099.530
22	121.599	2291.025	2736.410	0.000	20374.983	1789.985
26	-1067.931	2809.968	-5800.453	0.000	416.249	-15.367
27	-251.753	2291.041	-2860.001	0.000	-9303.698	4.581
38	-646.393	2951.684	8201.850	0.000	6485.428	7541.470
42	1306.772	4216.822	-8396.488	0.000	-3204.314	-29792.473
75	150.741	1397.703	4019.047	0.000	6458.950	-3311.900
143	81.396	1936.035	-3987.342	0.000	-590.152	-31255.437

Load Combination 23: AISC14-LRFD LC6a

Node	Rx	Ry	Rz	Rox	Roy	Roz
16	114.493	1300.212	3104.114	0.000	2088.182	-610.112
22	33.884	801.408	935.734	0.000	7240.795	645.000
26	-527.910	1379.531	-2548.111	0.000	-194.266	-4.641
27	-6.232	838.627	-945.077	0.000	-3918.264	4.177
38	-177.767	1053.614	3393.710	0.000	-182.975	2353.225
42	537.420	2151.746	-3842.564	0.000	-2988.814	-13490.433
75	54.242	416.740	1111.759	0.000	1675.817	-1350.004
143	-28.130	671.765	-1023.983	0.000	880.833	-13886.048

Load Combination 24: AISC14-LRFD LC6b

Node	Rx	Ry	Rz	Rox	Roy	Roz
16	112.646	1292.383	3050.997	0.000	2230.986	-604.047
22	33.612	798.184	926.020	0.000	7193.197	641.787
26	-521.651	1391.875	-2640.545	0.000	-220.563	-4.467
27	-0.795	842.876	-993.542	0.000	-3691.254	3.812
38	-177.765	1049.058	3361.543	0.000	66.671	2353.504
42	558.490	2153.663	-3882.311	0.000	-3124.907	-13612.269
75	50.476	411.614	1088.280	0.000	1737.884	-1312.046
143	-55.012	673.990	-1096.026	0.000	348.394	-13420.100

Load Combination 25: AISC14-LRFD LC7a

Node	Rx	Ry	Rz	Rox	Roy	Roz
16	113.569	1296.298	3077.556	0.000	2159.585	-607.080
22	33.748	799.796	930.877	0.000	7216.997	643.394
26	-524.780	1385.703	-2594.328	0.000	-207.415	-4.554
27	-3.513	840.751	-969.309	0.000	-3804.759	3.994
38	-177.766	1051.336	3377.627	0.000	-58.151	2353.365
42	547.955	2152.705	-3862.438	0.000	-3056.860	-13551.351
75	52.359	414.177	1100.020	0.000	1706.851	-1331.025

143	-41.571	672.877	-1060.005	0.000	614.613	-13653.073
-----	---------	---------	-----------	-------	---------	------------

## Load Combination 26: AISC14-LRFD LC7b

Node	Rx	Ry	Rz	Rox	Roy	Roz
16	113.569	1296.298	3077.556	0.000	2159.585	-607.080
22	33.748	799.796	930.877	0.000	7216.997	643.394
26	-524.780	1385.703	-2594.328	0.000	-207.415	-4.554
27	-3.513	840.751	-969.309	0.000	-3804.759	3.994
38	-177.766	1051.336	3377.627	0.000	-58.151	2353.365
42	547.955	2152.705	-3862.438	0.000	-3056.860	-13551.351
75	52.359	414.177	1100.020	0.000	1706.851	-1331.025
143	-41.571	672.877	-1060.005	0.000	614.613	-13653.073



## Search Information

**Address:** 1925 Massachusetts Ave, Cambridge, MA 02140, USA

**Coordinates:** 42.3894663, -71.11973300000001

**Elevation:** 37 ft

**Timestamp:** 2020-08-04T15:29:24.434Z

**Hazard Type:** Wind



### ASCE 7-16

MRI 10-Year ..... 75 mph

MRI 25-Year ..... 84 mph

MRI 50-Year ..... 91 mph

MRI 100-Year ..... 98 mph

Risk Category I ..... 109 mph

Risk Category II ..... 119 mph

Risk Category III ..... 128 mph

Risk Category IV ..... ⚠️ 132 mph

You are in a wind-borne debris region if you are also within 1 mile of the coastal mean high water line.

### ASCE 7-10

MRI 10-Year ..... 78 mph

MRI 25-Year ..... 88 mph

MRI 50-Year ..... 96 mph

MRI 100-Year ..... 103 mph

Risk Category I ..... 117 mph

Risk Category II ..... 127 mph

Risk Category III-IV ... ⚠️ 138 mph

If the structure under consideration is a healthcare facility and you are also within 1 mile of the coastal mean high water line, you are in a wind-borne debris region. If other occupancy, use the Risk Category II basic wind speed contours to determine if you are in a wind-borne debris region.

### ASCE 7-05

ASCE 7-05 Wind Speed ..... 104 mph

*The results indicated here DO NOT reflect any state or local amendments to the values or any delineation lines made during the building code adoption process. Users should confirm any output obtained from this tool with the local Authority Having Jurisdiction before proceeding with design.*

## Disclaimer

Hazard loads are interpolated from data provided in ASCE 7 and rounded up to the nearest whole integer. Per ASCE 7, islands and coastal areas outside the last contour should use the last wind speed contour of the coastal area – in some cases, this website will extrapolate past the last wind speed contour and therefore, provide a wind speed that is slightly higher. NOTE: For queries near wind-borne debris region boundaries, the resulting determination is sensitive to rounding which may affect whether or not it is considered to be within a wind-borne debris region.

Mountainous terrain, gorges, ocean promontories, and special wind regions shall be examined for unusual wind conditions.

## Search Information

**Address:** 1925 Massachusetts Ave, Cambridge, MA 02140, USA

**Coordinates:** 42.3894663, -71.11973300000001

**Elevation:** 37 ft

**Timestamp:** 2020-08-07T04:33:42.114Z

**Hazard Type:** Seismic

**Reference Document:** ASCE7-10

**Risk Category:** II

**Site Class:** D



### MCER Horizontal Response Spectrum

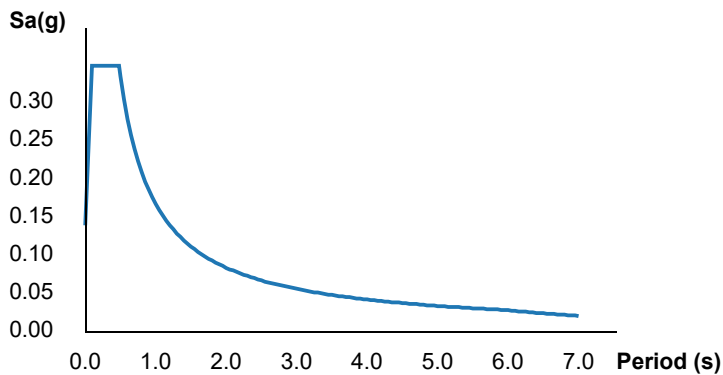

### Design Horizontal Response Spectrum

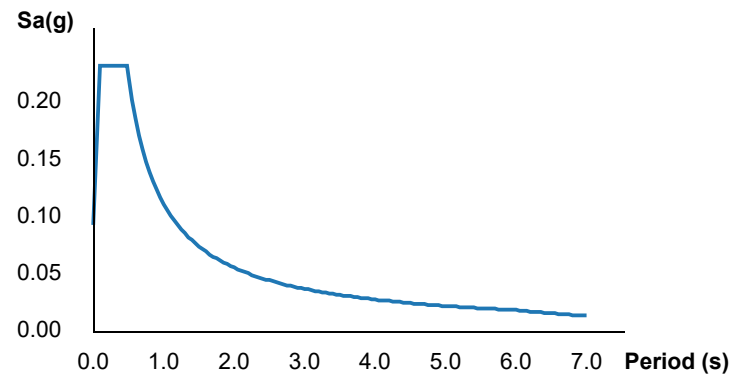

## Basic Parameters

Name	Value	Description
$S_S$	0.217	$MCE_R$ ground motion (period=0.2s)
$S_1$	0.07	$MCE_R$ ground motion (period=1.0s)
$S_{MS}$	0.348	Site-modified spectral acceleration value
$S_{M1}$	0.167	Site-modified spectral acceleration value
$S_{DS}$	0.232	Numeric seismic design value at 0.2s SA
$S_{D1}$	0.111	Numeric seismic design value at 1.0s SA

## Additional Information

Name	Value	Description
SDC	B	Seismic design category
$F_a$	1.6	Site amplification factor at 0.2s
$F_v$	2.4	Site amplification factor at 1.0s

CR <sub>S</sub>	0.892	Coefficient of risk (0.2s)
CR <sub>1</sub>	0.899	Coefficient of risk (1.0s)
PGA	0.117	MCE <sub>G</sub> peak ground acceleration
F <sub>PGA</sub>	1.567	Site amplification factor at PGA
PGA <sub>M</sub>	0.183	Site modified peak ground acceleration
T <sub>L</sub>	6	Long-period transition period (s)
SsRT	0.217	Probabilistic risk-targeted ground motion (0.2s)
SsUH	0.244	Factored uniform-hazard spectral acceleration (2% probability of exceedance in 50 years)
SsD	1.5	Factored deterministic acceleration value (0.2s)
S1RT	0.07	Probabilistic risk-targeted ground motion (1.0s)
S1UH	0.077	Factored uniform-hazard spectral acceleration (2% probability of exceedance in 50 years)
S1D	0.6	Factored deterministic acceleration value (1.0s)
PGAd	0.5	Factored deterministic acceleration value (PGA)

*The results indicated here DO NOT reflect any state or local amendments to the values or any delineation lines made during the building code adoption process. Users should confirm any output obtained from this tool with the local Authority Having Jurisdiction before proceeding with design.*

## Disclaimer

Hazard loads are provided by the U.S. Geological Survey [Seismic Design Web Services](#).

While the information presented on this website is believed to be correct, ATC and its sponsors and contributors assume no responsibility or liability for its accuracy. The material presented in the report should not be used or relied upon for any specific application without competent examination and verification of its accuracy, suitability and applicability by engineers or other licensed professionals. ATC does not intend that the use of this information replace the sound judgment of such competent professionals, having experience and knowledge in the field of practice, nor to substitute for the standard of care required of such professionals in interpreting and applying the results of the report provided by this website. Users of the information from this website assume all liability arising from such use. Use of the output of this website does not imply approval by the governing building code bodies responsible for building code approval and interpretation for the building site described by latitude/longitude location in the report.



Com-Ex Consultants, LLC • 115 Route 46, Suite E39 • Mountain Lakes, NJ • 07046  
Office: 862-209-4300 | Fax: 862-209-4301

**4DE7032A**  
**BO032/1923-1925 Mass Ave**

1923-1925 Massachusetts Ave., Cambridge, MA 02140  
(Middlesex County)

**Antenna Mount Structural Analysis**  
**Anchor Project**

August 27, 2020

<b>Item</b>	<b>Pass/Fail</b>	<b>Capacity</b>
Antenna Mount	Pass	20.3%
Anchor Bolts	Pass	18.2%
Parapet Wall	Pass	54.7%
Chimney	Pass	43.6%



**Nicholas D. Barile, P.E.**  
**MA PE License No. 51464**  
Com-Ex Project No. 20002-TRN



Com-Ex Consultants, LLC • 115 Route 46, Suite E39 • Mountain Lakes, NJ • 07046  
Office: 862-209-4300 | Fax: 862-209-4301

## **Executive Summary**

At the request of T-Mobile, Com-Ex Consultants has performed a structural analysis of the antenna mounting system for the proposed antennas and ancillary equipment per the *MA STATE BUILDING CODE 780 CMR 8TH ED.*, *ASCE 7*, *ANSI/TIA-222-G*, and *AISC (LRFD14)*. Information pertaining to the antenna mounts and connection brackets was obtained from:

- Site Visit notes & photos by Com-Ex Consultants dated 06/16/20.
- T-Mobile Anchor RFDS dated 05/21/20.
- Construction Drawings completed by Com-Ex Consultants dated 08/27/20.

## **Discussion**

Gravity loading change is less than 0.1% of overall gravity loading; therefore, a full rigorous analysis of the structure and its foundation is not required.

## **Conclusions**

Per our analysis, the antenna mounts at each sector can support the proposed loading per the *MA STATE BUILDING CODE 780 CMR 8TH ED.*, *ANSI/TIA-222-G standards*.

## **General Comments**

If there are substantial modifications to be made or the assumptions made in this analysis are not accurate, Com-Ex Consultants should be notified immediately to perform a revised analysis. This report is not a conditions assessment and assumes that good workmanship will be used and systems will be properly maintained.

## **Limitations**

All opinions and conclusions are considered accurate to a reasonable degree of engineering certainty based upon the evidence available at the time of this report. All opinions and conclusions are subject to revision based upon receipt of new or additional/updated information. All services are provided exercising a level of care and diligence equivalent to the standard and care of our profession. No other warranty or guarantee, expressed or implied, is offered. Our services are confidential in nature and we will not release this report to any other party without the client's consent. The use of this engineering work is limited to the express purpose for which it was commissioned and it may not be reused, copied, or distributed for any other purpose without the written consent of Com-Ex Consultants.



Com-Ex Consultants, LLC • 115 Route 46, Suite E39 • Mountain Lakes, NJ • 07046  
Office: 862-209-4300 | Fax: 862-209-4301

**Attachment A**  
**Proposed Equipment Configuration**

**Final Alpha Sector Antenna Configuration**

***Rad Center for Antennas is 49'-0"***

- (1) (N) AIR32 KRD901146-1\_B66A\_B2A Ericsson Antenna
- (1) (N) APXAARR18\_43-U-NA20 RFS Antenna
- (1) (N) AIR6449 B41 Ericsson Antenna
- (1) (N) 4415 B25 Ericsson RRU
- (1) (N) 4449 B71+B85 Ericsson RRU
- (1) (E) Generic Twin Style 1B – AWS
- (1) (N) AWS/PCS (8:4) MI-54131 Microdata Telecom Diplexer

**Final Beta Sector Antenna Configuration**

***Rad Center for Antennas is 45'-0"***

- (1) (N) AIR32 KRD901146-1\_B66A\_B2A Ericsson Antenna
- (1) (N) APXAARR18\_43-U-NA20 RFS Antenna
- (1) (N) AIR6449 B41 Ericsson Antenna
- (1) (N) 4415 B25 Ericsson RRU
- (1) (N) 4449 B71+B85 Ericsson RRU
- (1) (E) Generic Twin Style 1B – AWS
- (1) (N) AWS/PCS (8:4) MI-54131 Microdata Telecom Diplexer

**Final Gamma Sector Antenna Configuration**

***Rad Center for Antennas is 53'-0"***

- (1) (N) AIR32 KRD901146-1\_B66A\_B2A Ericsson Antenna
- (1) (N) APXAARR18\_43-U-NA20 RFS Antenna
- (1) (N) AIR6449 B41 Ericsson Antenna
- (1) (N) 4415 B25 Ericsson RRU
- (1) (N) 4449 B71+B85 Ericsson RRU
- (1) (E) Generic Twin Style 1B – AWS
- (1) (N) AWS/PCS (8:4) MI-54131 Microdata Telecom Diplexer

**Final Delta Sector Antenna Configuration**

***Rad Center for Antennas is 45'-0"***

- (1) (N) AIR32 KRD901146-1\_B66A\_B2A Ericsson Antenna
- (1) (N) APXAARR18\_43-U-NA20 RFS Antenna
- (1) (N) AIR6449 B41 Ericsson Antenna
- (1) (N) 4415 B25 Ericsson RRU
- (1) (N) 4449 B71+B85 Ericsson RRU
- (1) (E) Generic Twin Style 1B – AWS
- (1) (N) AWS/PCS (8:4) MI-54131 Microdata Telecom Diplexer

**Wind Analysis F = qz x Gh x ( EPA ) per TIA-222-G**

**qz = 0.00256 x Kz x Kzt x Kd x V^2 x I**

**Kz=2.01 (Z/Zg)^(2/α) = 0.850**  
 Zg = 1200 Table 2-4 Exposure B  
 Alpha (α) = 7 Table 2-4  
 Z= 45 ft, 49ft, 53ft  
 Terrain Category I  
**Kzt = (1+KeKt/Kh)^2 = 1.00** for Category I  
 Ke= 1.00 Table 2-4  
 Kt= 0.53 Table 2-5  
**Kh=e^(f \* z/H) = 0.000** for H=0  
 f= 2.00 Table 2-5  
 H =Height of Crest Surrounding Terrain 0.00 ft  
 Kz = 0.850  
 Kzt = 1.0  
 Kd = 0.95  
 Importance Factor Table 2-3 = I = 1.0 Use Class II  
 Vult = 117 mph  
 Vasd = x Vult x (0.6)^1/2 = 90.6 mph  
**qz = 0.00256 x Kz x Kzt x Kd x V^2 x I = 17.0 psf**  
 Gh = 1.00  
**qz Gh = 17.0 psf**

	Equipment Loading	CaAa (sf or sf/lf)	Wind (psf)	Wind Load (lb)	Weight (lb)
FN1	AIR32 KRD901146-1_B66A_B2A	6.51	17.0	110.5	132.2
FN2	APXAARR18_43-U-NA20	14.67	17.0	249.1	131.3
FN3	AIR6449 B41	5.65	17.0	95.9	103
FN4	4449 B71+B85	1.680	17.0	28.5	74
FN5	4415 B25	1.84	17.0	31.2	46
FN6	Generic Twin Style 1B - AWS	0.49	17.0	8.3	12.1
FN7	AWS/PCS (8:4) MI-54131 Microdata Telecom D	0.29	17.0	4.9	6.61
	1-1/4" std. pipe	0.163	17.0	2.8	
	2-1/2" std. pipe	0.288	17.0	4.9	
	3"X3" Angle	0.500	17.0	8.5	
FT1	AIR32 KRD901146-1_B66A_B2A	4.71	17.0	80.0	132.2
FT2	APXAARR18_43-U-NA20	6.16	17.0	104.6	131.3
FT3	AIR6449 B41	2.42	17.0	41.1	103
FT4	4449 B71+B85	1.290	17.0	21.9	74
FT5	4415 B25	0.820	17.0	13.9	46
FT6	Generic Twin Style 1B - AWS	0.440	17.0	7.5	12.1
FT7	AWS/PCS (8:4) MI-54131 Microdata Telecom D	0.21	17.0	3.6	6.61

**ALPHA**

5/8" Anchor Bolts w/ Hilti HY-270 epoxy

$$\begin{aligned}
 \text{Tensile Capacity} = P_c &= 1,025.0 \text{ lb} \\
 \text{Shear capacity} = V_c &= 1,405.0 \text{ lb} \\
 R_x &= 48.8 \text{ lb} \\
 R_y &= 107.8 \text{ lb} \\
 R_z &= 287.3 \text{ lb} \\
 V_s = (R_x^2 + R_y^2)^{1/2} &= 118.3 \text{ lb} \\
 \text{Capacity} = [(R_z / (P_c \times 2 \text{ bolts})) + (V_s / (V_c \times 2 \text{ bolts}))] \times 100\% &= 18.2\%
 \end{aligned}$$

**OK**

**Chimney Check**

$$\begin{aligned}
 R_{ox} &= 30,301 \text{ in-lb (Allowable)} \\
 S_x = \pi(d_o^4 - d^4) / (32d_o) &= 5,120.0 \text{ in}^3 \\
 d_o &= 32.000 \text{ in} \\
 d &= 16 \text{ in} \\
 \text{Chimney Height} &= 102 \text{ in} \\
 \\ 
 M_{r2} = 1.3 \times b \times \text{Wind Pressure} \times h^2 / 2 &= 25,516 \text{ in-lb (Parapet Wind)} \\
 M_r = M_{r1} + M_{r2} &= 55,817 \text{ in-lb} \\
 \sigma = M_r / S_x &= 10.90 \text{ psi - Stress on brick} \\
 \sigma_{\text{brick}} &= 25 \text{ psi} \\
 \text{Capacity} = \sigma / \sigma_{\text{brick}} \times 100\% &= 43.6\%
 \end{aligned}$$

**OK**

**BETA**

5/8" Anchor Bolts w/ Hilti HY-270 epoxy

$$\begin{aligned}
 \text{Tensile Capacity} = P_c &= 1,025.0 \text{ lb} \\
 \text{Shear capacity} = V_c &= 1,405.0 \text{ lb} \\
 R_x &= - \text{ lb} \\
 R_y &= 105.3 \text{ lb} \\
 R_z &= 86.9 \text{ lb} \\
 V_s = (R_x^2 + R_y^2)^{1/2} &= 105.3 \text{ lb} \\
 \text{Capacity} = [(R_z / (P_c \times 2 \text{ bolts})) + (V_s / (V_c \times 2 \text{ bolts}))] \times 100\% &= 8.0\%
 \end{aligned}$$

**OK**

**Parapet Wall Check**

$$\begin{aligned}
 R_{ox} &= 2,183.8 \text{ in-lb (Allowable)} \\
 S_x = b \times t^2 / 6 &= 1,296 \text{ in}^3 \\
 b &= 54 \text{ in - Parapet support section} \\
 t &= 12 \text{ in - Parapet thickness} \\
 h &= 60 \text{ in - Parapet Height Average} \\
 \\ 
 M_{r2} = 1.3 \times b \times \text{Wind Pressure} \times h^2 / 2 &= 14,899 \text{ in-lb (Parapet Wind)} \\
 M_r = M_{r1} + M_{r2} &= 17,083 \text{ in-lb} \\
 \sigma = M_r / S_x &= 13.18 \text{ psi - Stress on brick} \\
 \sigma_{\text{brick}} &= 25 \text{ psi} \\
 \text{Capacity} = \sigma / \sigma_{\text{brick}} \times 100\% &= 52.7\%
 \end{aligned}$$

**OK**



Company/Project: SZS Engineering / 20002-TRA

**VersaFrame V8.11 (608.0)**  
(C) Digital Canal Corp.

Engineer: Sam Gonzalez

Date/Time: 08/04/20 11:05:44

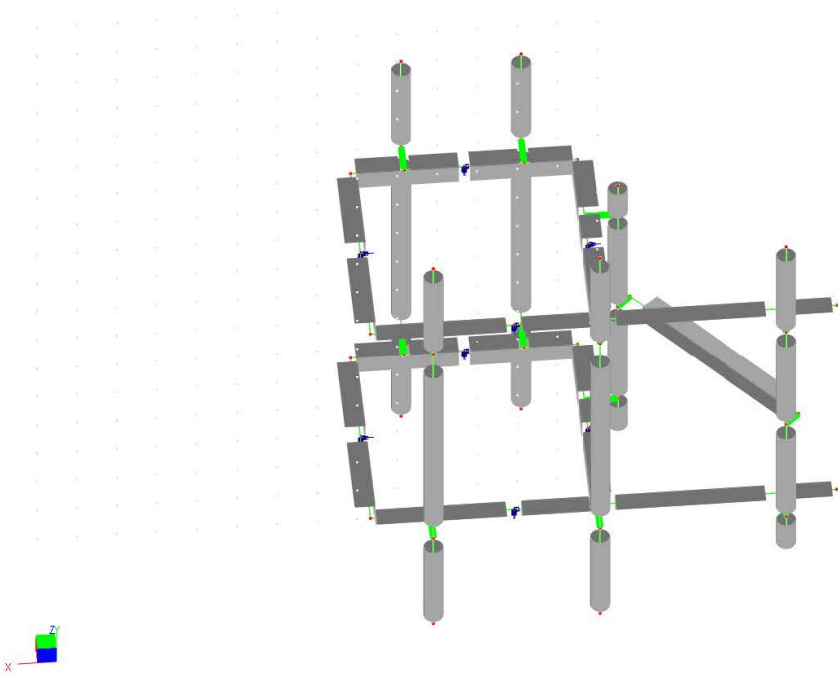

**Note:**

Company/Project: SZS Engineering / 20002-TRA

**VersaFrame V8.11 (608.0)**  
(C) Digital Canal Corp.

Engineer: Sam Gonzalez

Date/Time: 08/04/20 11:05:22

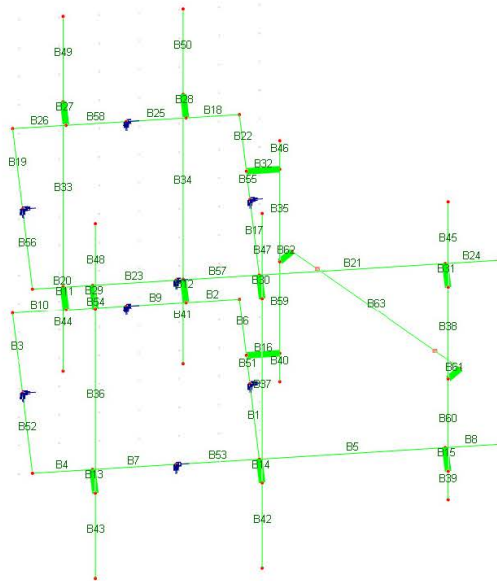

**Note:**

Company/Project: SZS Engineering / 20002-TRA

**VersaFrame V8.11 (608.0)**  
(C) Digital Canal Corp.

Engineer: Sam Gonzalez

Date/Time: 08/04/20 11:05:04

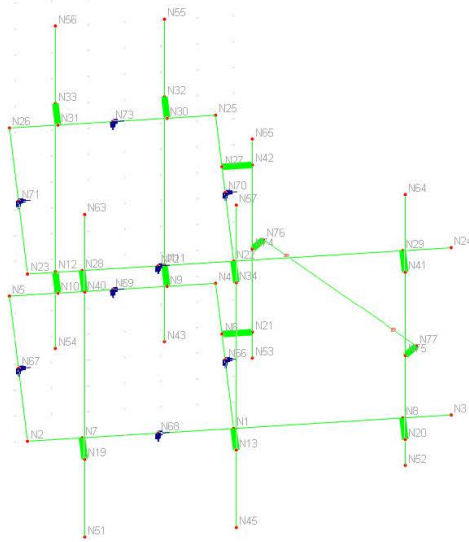

**Note:**

Company/Project: SZS Engineering / 20002-TRA

**VersaFrame V8.11 (608.0)**  
(C) Digital Canal Corp.

Engineer: Sam Gonzalez

Date/Time: 08/04/20 11:09:35

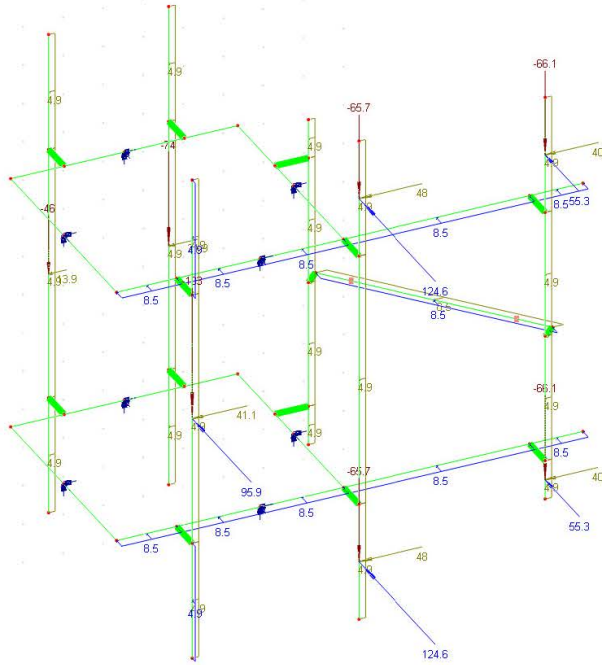

**Note:**

TIA-222-G-2.3.1_30	x			-	-
TIA-222-G-2.3.1_60	x			-	-
TIA-222-G-2.3.1_90	x			-	-
TIA-222-G-2.3.1_120	x			-	-
TIA-222-G-2.3.1_150	x			-	-
TIA-222-G-2.3.1_180	x			-	-
TIA-222-G-2.3.1_210	x			-	-
TIA-222-G-2.3.1_240	x			-	-
TIA-222-G-2.3.1_270	x			-	-
TIA-222-G-2.3.1_300	x			-	-
TIA-222-G-2.3.1_330	x			-	-

## INPUT Contents

- General:
- Geometry: [[Nodes](#)] [[Supports](#)] [[Moment Releases](#)]
- Loads: [[Point Loads](#)] [[Line Loads](#)]

## OUTPUT Contents

- Nodal: [[Support Reactions](#)]
  - Members:
-

**Nodes**

Units: Coordinates X, Y, Z [in]

No.	X	Y	Z	No.	X	Y	Z
1	0.00	0.00	0.00	2	34.00	0.00	0.00
3	-36.00	0.00	0.00	4	0.00	0.00	34.00
5	34.00	0.00	34.00	6	0.00	0.00	22.00
7	25.00	0.00	0.00	8	-28.00	0.00	0.00
9	8.00	0.00	34.00	10	26.00	0.00	34.00
11	8.00	0.00	39.00	12	26.00	0.00	39.00
13	0.00	0.00	-5.00	19	25.00	0.00	-5.00
20	-28.00	0.00	-5.00	21	-5.00	0.00	22.00
22	0.00	39.00	0.00	23	34.00	39.00	0.00
24	-36.00	39.00	0.00	25	0.00	39.00	34.00
26	34.00	39.00	34.00	27	0.00	39.00	22.00
28	25.00	39.00	0.00	29	-28.00	39.00	0.00
30	8.00	39.00	34.00	31	26.00	39.00	34.00
32	8.00	39.00	39.00	33	26.00	39.00	39.00
34	0.00	39.00	-5.00	40	25.00	39.00	-5.00
41	-28.00	39.00	-5.00	42	-5.00	39.00	22.00
43	8.00	-18.00	39.00	45	0.00	-18.00	-5.00
51	25.00	-18.00	-5.00	52	-28.00	-6.00	-5.00
53	-5.00	-6.00	22.00	54	26.00	-18.00	39.00
55	8.00	57.00	39.00	56	26.00	57.00	39.00
57	0.00	57.00	-5.00	63	25.00	57.00	-5.00
64	-28.00	57.00	-5.00	65	-5.00	45.00	22.00
66	0.00	0.00	16.00	67	34.00	0.00	17.00
68	12.50	0.00	0.00	69	17.00	0.00	34.00
70	0.00	39.00	16.00	71	34.00	39.00	17.00
72	12.50	39.00	0.00	73	17.00	39.00	34.00
74	-5.00	19.50	22.00	75	-28.00	19.50	-5.00
76	-7.00	19.50	24.00	77	-30.00	19.50	-3.00

**Supports**

Units: Forced Displacements Dx, Dy, Dz [in]; Dox, Doy, Doz [rad]

Node	Flag	Dx	Dy	Dz	Dox	Doy	Doz
66	111110	0.000	0.000	0.000	0.000	0.000	0.000
67	111110	0.000	0.000	0.000	0.000	0.000	0.000
68	111011	0.000	0.000	0.000	0.000	0.000	0.000
69	111011	0.000	0.000	0.000	0.000	0.000	0.000
70	111110	0.000	0.000	0.000	0.000	0.000	0.000
71	111110	0.000	0.000	0.000	0.000	0.000	0.000
72	111011	0.000	0.000	0.000	0.000	0.000	0.000
73	111011	0.000	0.000	0.000	0.000	0.000	0.000

**Moment Releases**

Member ID	Begin OZ	End OZ	Begin OY	End OY	Torsion OX
63	1	1	0	0	0

**Point Loads**

Units: Force [lb]; Moment [lb-in]; Coord-Sys: Local=0, Global=1;  
 Direction: 0=X, 1=Y, 2=Z, 3=OX, 4=OY, 5=OZ

\*\*\*\*\* LOAD CASE - [ Dead ]\*\*\*\*\*

Member	Coord-Sys	Direction	Value	Distance
33	1	1	-46.000	0.5
34	1	1	-74.000	0.5
36	1	1	-103.000	0.5
39	1	1	-66.100	0.5
42	1	1	-65.700	0.5
45	1	1	-66.100	0.5
47	1	1	-65.700	0.5

\*\*\*\*\* LOAD CASE - [ Wind ]\*\*\*\*\*

Member	Coord-Sys	Direction	Value	Distance
36	1	2	95.900	0.5
39	1	2	55.300	0.5
42	1	2	124.600	0.5
45	1	2	55.300	0.5
47	1	2	124.600	0.5

\*\*\*\*\* LOAD CASE - [ WindTransverse ]\*\*\*\*\*

Member	Coord-Sys	Direction	Value	Distance
33	1	0	13.900	0.5
34	1	0	21.900	0.5
36	1	0	41.100	0.5
39	1	0	40.000	0.5
42	1	0	48.000	0.5
45	1	0	40.000	0.5
47	1	0	48.000	0.5

**Line Loads**

Units: Force [lb/ft]; Coord-Sys: Local=0, Global=1; Direction: 0=X, 1=Y, 2=Z

\*\*\*\*\* LOAD CASE - [ Wind ]\*\*\*\*\*

Member	Coord-Sys	Direction	Value1	Value2	Distance1	Distance2
4	1	2	8.500	8.500	0	1
5	1	2	8.500	8.500	0	1
7	1	2	8.500	8.500	0	1
8	1	2	8.500	8.500	0	1
20	1	2	8.500	8.500	0	1
21	1	2	8.500	8.500	0	1
23	1	2	8.500	8.500	0	1
24	1	2	8.500	8.500	0	1
43	1	2	4.900	4.900	0	1
48	1	2	4.900	4.900	0	1
53	1	2	8.500	8.500	0	1
57	1	2	8.500	8.500	0	1

\*\*\*\*\* LOAD CASE - [ WindTransverse ]\*\*\*\*\*

Member	Coord-Sys	Direction	Value1	Value2	Distance1	Distance2
33	1	0	4.900	4.900	0	1
34	1	0	4.900	4.900	0	1
35	1	0	4.900	4.900	0	1
36	1	0	4.900	4.900	0	1
37	1	0	4.900	4.900	0	1
38	1	0	4.900	4.900	0	1
39	1	0	4.900	4.900	0	1
40	1	0	4.900	4.900	0	1
41	1	0	4.900	4.900	0	1
42	1	0	4.900	4.900	0	1
43	1	0	4.900	4.900	0	1
44	1	0	4.900	4.900	0	1
45	1	0	4.900	4.900	0	1
46	1	0	4.900	4.900	0	1
47	1	0	4.900	4.900	0	1
48	1	0	4.900	4.900	0	1
49	1	0	4.900	4.900	0	1
50	1	0	4.900	4.900	0	1
59	1	0	4.900	4.900	0	1
60	1	0	4.900	4.900	0	1
63	1	0	8.500	8.500	0	1

**Support Reactions**

Units: Force Reactions Rx, Ry, Rz [lb]; Moment Reactions Rox, Roy, Roz [lb-in]

Load Combination 14: TIA-222-G-2.3.1 0 ALLOWABLE

Node	Rx	Ry	Rz	Rox	Roy	Roz
66	-48.769	107.803	-287.297	136.170	36.692	0.000



67	-12.280	46.590	-39.896	371.804	58.838	0.000
68	-68.101	237.968	-25.109	0.000	337.340	-489.903
69	-28.101	124.454	14.941	0.000	-26.172	-199.333
70	-48.157	168.518	-214.627	1786.400	73.583	0.000
71	-5.857	24.205	-30.927	0.996	41.638	0.000
72	237.110	169.703	42.276	0.000	363.592	-1363.322
73	-25.846	113.793	-28.928	0.000	-54.329	32.107

Load Combination 15: TIA-222-G-2.3.1 30 ALLOWABLE

Node	Rx	Ry	Rz	Rox	Roy	Roz
66	-44.325	118.350	-250.179	282.828	-1.658	0.000
67	-12.514	47.808	-36.542	372.489	54.251	0.000
68	-161.465	213.363	-30.427	0.000	225.082	-495.416
69	-46.062	124.500	16.962	0.000	6.704	-168.015
70	-41.376	157.035	-171.606	1630.402	23.739	0.000
71	-6.091	22.986	-27.573	0.305	37.051	0.000
72	132.103	195.244	33.028	0.000	236.000	-1354.887
73	-43.807	113.748	-26.907	0.000	-21.453	0.779

Load Combination 16: TIA-222-G-2.3.1 60 ALLOWABLE

Node	Rx	Ry	Rz	Rox	Roy	Roz
66	-29.801	134.014	-160.474	609.494	-35.485	0.000
67	-10.255	45.700	-24.600	323.311	37.434	0.000
68	-250.876	186.386	-34.126	0.000	58.577	-616.080
69	-51.982	123.106	20.315	0.000	41.556	-114.083
70	-21.710	140.317	-68.169	1293.366	-36.551	0.000
71	-3.833	25.094	-15.631	49.470	20.235	0.000
72	31.017	223.273	21.454	0.000	39.101	-1231.335
73	-49.725	115.144	-23.554	0.000	13.399	-53.169

Load Combination 17: TIA-222-G-2.3.1 90 ALLOWABLE

Node	Rx	Ry	Rz	Rox	Roy	Roz
66	-9.088	150.607	-42.201	1028.666	-55.733	0.000
67	-6.109	40.833	-7.267	237.449	12.889	0.000
68	-312.392	164.260	-35.216	0.000	-117.590	-819.563
69	-44.275	120.645	24.103	0.000	69.050	-51.984
70	5.574	122.834	67.988	865.566	-91.140	0.000
71	0.313	29.962	1.702	135.315	-4.308	0.000
72	-39.080	246.286	10.656	0.000	-174.377	-1025.769
73	-42.017	117.608	-19.766	0.000	40.895	-115.287

Load Combination 18: TIA-222-G-2.3.1 120 ALLOWABLE

Node	Rx	Ry	Rz	Rox	Roy	Roz
66	12.261	163.686	72.939	1427.953	-56.980	0.000
67	-1.186	34.509	10.812	137.917	-12.804	0.000
68	-329.506	152.921	-33.401	0.000	-256.186	-1051.341
69	-25.006	117.777	27.309	0.000	81.811	1.626
70	33.161	109.269	200.369	461.715	-125.392	0.000
71	5.236	36.287	19.780	234.831	-30.000	0.000
72	-59.378	258.108	3.534	0.000	-347.188	-793.273
73	-22.746	120.478	-16.560	0.000	53.657	-168.913

Load Combination 19: TIA-222-G-2.3.1 150 ALLOWABLE

Node	Rx	Ry	Rz	Rox	Roy	Roz
66	28.525	169.746	154.091	1700.332	-38.908	0.000
67	3.194	28.425	24.791	51.390	-32.761	0.000
68	-297.646	155.407	-29.168	0.000	-320.075	-1249.305
69	0.655	115.271	29.074	0.000	76.418	32.371
70	53.655	103.258	293.492	190.057	-130.130	0.000
71	9.615	42.373	33.759	321.347	-49.957	0.000
72	-24.450	255.570	1.999	0.000	-433.011	-596.146
73	2.916	122.985	-14.794	0.000	48.266	-199.669

Load Combination 20: TIA-222-G-2.3.1 180 ALLOWABLE

Node	Rx	Ry	Rz	Rox	Roy	Roz
66	35.350	167.159	179.524	1772.901	-6.353	0.000
67	5.858	24.207	30.928	1.026	-41.638	0.000
68	-225.344	171.053	-23.651	0.000	-292.151	-1360.469
69	25.837	113.799	28.926	0.000	54.317	32.025

70	61.570	106.415	322.424	123.300	-104.087	0.000
71	12.280	46.591	39.896	371.708	-58.834	0.000
72	56.351	239.352	6.462	0.000	-408.869	-487.150
73	28.099	124.457	-14.943	0.000	26.166	-199.323

## Load Combination 21: TIA-222-G-2.3.1 210 ALLOWABLE

Node	Rx	Ry	Rz	Rox	Roy	Roz
66	30.906	156.610	142.404	1626.191	31.973	0.000
67	6.091	22.989	27.574	0.331	-37.052	0.000
68	-131.974	195.666	-18.329	0.000	-179.878	-1355.004
69	43.791	113.755	26.904	0.000	21.431	0.683
70	54.785	117.903	279.392	279.355	-54.236	0.000
71	12.514	47.810	36.542	372.409	-54.248	0.000
72	161.370	213.801	15.724	0.000	-281.222	-495.535
73	46.053	124.501	-16.965	0.000	-6.720	-167.972

## Load Combination 22: TIA-222-G-2.3.1 240 ALLOWABLE

Node	Rx	Ry	Rz	Rox	Roy	Roz
66	16.388	140.930	52.700	1299.609	65.806	0.000
67	3.833	25.096	15.631	49.479	-20.235	0.000
68	-42.568	222.644	-14.631	0.000	-13.378	-1234.394
69	49.712	115.149	23.551	0.000	-13.419	-53.237
70	35.124	134.637	175.956	616.305	6.052	0.000
71	10.255	45.704	24.600	323.274	-37.433	0.000
72	262.450	185.770	27.295	0.000	-84.333	-619.031
73	51.972	123.104	-20.318	0.000	-41.570	-114.035

## Load Combination 23: TIA-222-G-2.3.1 270 ALLOWABLE

Node	Rx	Ry	Rz	Rox	Roy	Roz
66	-4.320	124.323	-65.570	880.571	86.083	0.000
67	-0.313	29.963	-1.702	135.321	4.309	0.000
68	18.936	244.764	-13.546	0.000	162.768	-1030.916
69	42.012	117.609	19.765	0.000	-40.903	-115.301
70	7.850	152.131	39.812	1043.961	60.635	0.000
71	6.109	40.836	7.267	237.449	-12.890	0.000
72	332.529	162.767	38.078	0.000	129.082	-824.593
73	44.271	120.642	-24.104	0.000	-69.055	-51.951

## Load Combination 24: TIA-222-G-2.3.1 300 ALLOWABLE

Node	Rx	Ry	Rz	Rox	Roy	Roz
66	-25.670	111.246	-180.708	481.335	87.354	0.000
67	-5.236	36.287	-19.781	234.863	30.003	0.000
68	36.045	256.095	-15.364	0.000	301.349	-799.088
69	22.750	120.475	16.560	0.000	-53.654	-168.886
70	-19.732	165.692	-92.558	1447.754	94.881	0.000
71	1.187	34.510	-10.811	137.923	12.803	0.000
72	352.815	150.956	45.188	0.000	301.839	-1057.139
73	25.007	117.774	-27.309	0.000	-81.807	1.651

## Load Combination 25: TIA-222-G-2.3.1 330 ALLOWABLE

Node	Rx	Ry	Rz	Rox	Roy	Roz
66	-41.939	105.201	-261.861	208.873	69.276	0.000
67	-9.616	42.373	-33.760	321.420	49.961	0.000
68	4.191	253.607	-19.596	0.000	365.244	-601.070
69	-2.911	122.980	14.795	0.000	-48.262	-199.644
70	-40.231	171.687	-185.683	1719.498	99.620	0.000
71	-3.193	28.423	-24.790	51.378	32.760	0.000
72	317.892	153.495	46.725	0.000	387.671	-1254.322
73	-0.656	115.267	-29.074	0.000	-76.418	32.417

# Steel Check Report

Project:: 20002-TRN  
 Description: Antenna Mount  
 Date: 08/04/2020 11:07 AM

Company: SZS Engineering  
 User: Sam Gonzalez  
 Software: Digital Canal VersaFrame

## Code Check Results (LRFD14)

### CRITICAL STRESS SUMMARY

ID	Section Name	Status	Governing Criteria	Stress Ratio	Load Combination	Distance (ft)
1	L3X3X1/4	OK	Axial-Bending	0.0840	TIA-222-G-2.3.1_180	1.3333
2	L3X3X1/4	OK	Axial-Bending	0.0095	TIA-222-G-2.3.1_180	0.6669
3	L3X3X1/4	OK	Axial-Bending	0.0068	TIA-222-G-2.3.1_90	1.4167
4	L3X3X1/4	OK	Axial-Bending	0.0196	TIA-222-G-2.3.1_30	0.7500
5	L3X3X1/4	OK	Axial-Bending	0.0981	TIA-222-G-2.3.1_180	2.3333
6	L3X3X1/4	OK	Axial-Bending	0.0224	TIA-222-G-2.3.1_180	0.0000
7	L3X3X1/4	OK	Axial-Bending	0.0507	TIA-222-G-2.3.1_0	1.0417
8	L3X3X1/4	OK	Axial-Bending	0.0018	TIA-222-G-2.3.1_0	0.0000
9	L3X3X1/4	OK	Axial-Bending	0.0239	TIA-222-G-2.3.1_330	0.7497
10	L3X3X1/4	OK	Axial-Bending	0.0050	TIA-222-G-2.3.1_90	0.0000
17	L3X3X1/4	OK	Axial-Bending	0.0860	TIA-222-G-2.3.1_0	0.0000
18	L3X3X1/4	OK	Axial-Bending	0.0099	TIA-222-G-2.3.1_0	0.6669
19	L3X3X1/4	OK	Axial-Bending	0.0079	TIA-222-G-2.3.1_270	1.4167
20	L3X3X1/4	OK	Axial-Bending	0.0127	TIA-222-G-2.3.1_210	0.7500
21	L3X3X1/4	OK	Axial-Bending	0.1001	TIA-222-G-2.3.1_0	0.0000
22	L3X3X1/4	OK	Axial-Bending	0.0149	TIA-222-G-2.3.1_180	0.0000
23	L3X3X1/4	OK	Axial-Bending	0.0425	TIA-222-G-2.3.1_180	1.0417
24	L3X3X1/4	OK	Axial-Bending	0.0018	TIA-222-G-2.3.1_0	0.0000
25	L3X3X1/4	OK	Axial-Bending	0.0263	TIA-222-G-2.3.1_180	0.7497
26	L3X3X1/4	OK	Axial-Bending	0.0042	TIA-222-G-2.3.1_270	0.0000
33	Pipe2-1/2STD	OK	Axial-Bending	0.0132	TIA-222-G-2.3.1_270	3.2500
34	Pipe2-1/2STD	OK	Axial-Bending	0.0174	TIA-222-G-2.3.1_90	3.2500
35	Pipe2-1/2STD	OK	Axial-Bending	0.0341	TIA-222-G-2.3.1_180	1.6250
36	Pipe2-1/2STD	OK	Axial-Bending	0.0330	TIA-222-G-2.3.1_330	3.2500
37	Pipe2-1/2STD	OK	Axial-Bending	0.0649	TIA-222-G-2.3.1_240	0.0000
38	Pipe2-1/2STD	OK	Axial-Bending	0.0593	TIA-222-G-2.3.1_240	0.0000
39	Pipe2-1/2STD	OK	Axial-Bending	0.0085	TIA-222-G-2.3.1_210	0.0000
40	Pipe2-1/2STD	OK	Axial-Bending	0.0003	TIA-222-G-2.3.1_270	0.0000
41	Pipe2-1/2STD	OK	Axial-Bending	0.0025	TIA-222-G-2.3.1_270	0.0000
42	Pipe2-1/2STD	OK	Axial-Bending	0.0461	TIA-222-G-2.3.1_210	0.0000
43	Pipe2-1/2STD	OK	Axial-Bending	0.0034	TIA-222-G-2.3.1_210	0.0000
44	Pipe2-1/2STD	OK	Axial-Bending	0.0025	TIA-222-G-2.3.1_90	0.0000
45	Pipe2-1/2STD	OK	Axial-Bending	0.0248	TIA-222-G-2.3.1_210	0.0000
46	Pipe2-1/2STD	OK	Axial-Bending	0.0003	TIA-222-G-2.3.1_270	0.0000
47	Pipe2-1/2STD	OK	Axial-Bending	0.0462	TIA-222-G-2.3.1_210	0.0000
48	Pipe2-1/2STD	OK	Axial-Bending	0.0034	TIA-222-G-2.3.1_120	0.0000
49	Pipe2-1/2STD	OK	Axial-Bending	0.0026	TIA-222-G-2.3.1_90	0.0000
50	Pipe2-1/2STD	OK	Axial-Bending	0.0026	TIA-222-G-2.3.1_270	0.0000
51	L3X3X1/4	OK	Axial-Bending	0.0374	TIA-222-G-2.3.1_0	0.0000
52	L3X3X1/4	OK	Axial-Bending	0.0251	TIA-222-G-2.3.1_30	0.0000
53	L3X3X1/4	OK	Axial-Bending	0.0764	TIA-222-G-2.3.1_240	0.0000
54	L3X3X1/4	OK	Axial-Bending	0.0145	TIA-222-G-2.3.1_90	0.0000
55	L3X3X1/4	OK	Axial-Bending	0.0299	TIA-222-G-2.3.1_180	0.0000
56	L3X3X1/4	OK	Axial-Bending	0.0302	TIA-222-G-2.3.1_210	0.0000
57	L3X3X1/4	OK	Axial-Bending	0.0775	TIA-222-G-2.3.1_30	0.0000
58	L3X3X1/4	OK	Axial-Bending	0.0133	TIA-222-G-2.3.1_270	0.0000
59	Pipe2-1/2STD	OK	Axial-Bending	0.0342	TIA-222-G-2.3.1_0	0.0000
60	Pipe2-1/2STD	OK	Axial-Bending	0.0575	TIA-222-G-2.3.1_180	1.6250
63	L3X3X1/4	OK	Axial-Bending	0.0127	TIA-222-G-2.3.1_150	2.9557

### SELECTED LOAD COMBINATIONS

Load Combination	Code Check	Total	Live	Dependent	Conditional
TIA-222-G-2.3.1_0	x			-	-

	Node Id	Rx [lb]	Ry [lb]	Rz [lb]	Rox [lb-in]	Roy [lb-in]	Roz [lb-in]
1	78	-26.585	226.932	471.806	19366.796	189.080	769.522
2	79	9.013	-26.277	118.764	2688.962	-108.120	-282.004
3	80	-127.417	854.753	-21.494	-575.089	132.334	-3289.113
4	81	144.989	-62.374	25.614	912.227	235.998	-2542.847
5	Sum	0.000	993.034	594.690	22392.897	449.291	-5344.441

Company/Project: SZS Engineering / 20002-TRN

**VersaFrame V8.11 (608.0)**  
(C) Digital Canal Corp.

Engineer: Sam Gonzalez

Date/Time: 08/04/20 09:46:12

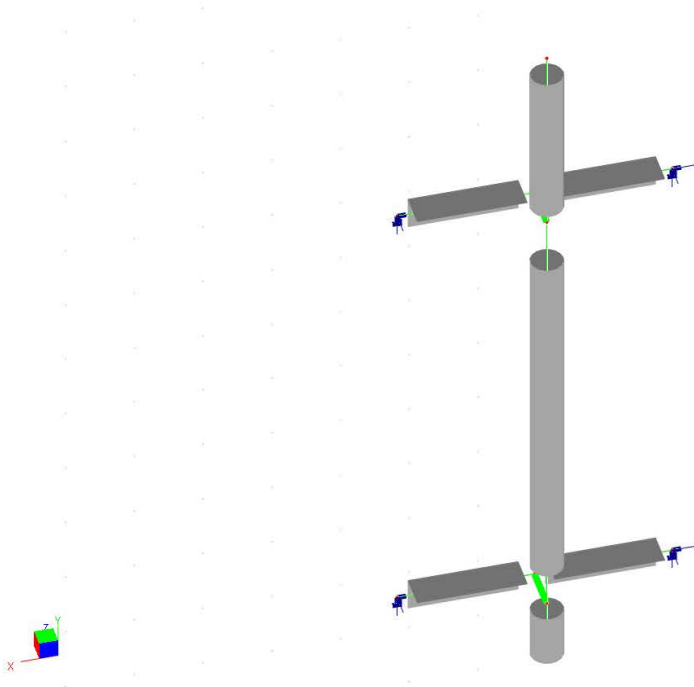

**Note:**

Company/Project: SZS Engineering / 20002-TRN

**VersaFrame V8.11 (608.0)**  
(C) Digital Canal Corp.

Engineer: Sam Gonzalez

Date/Time: 08/04/20 10:08:20

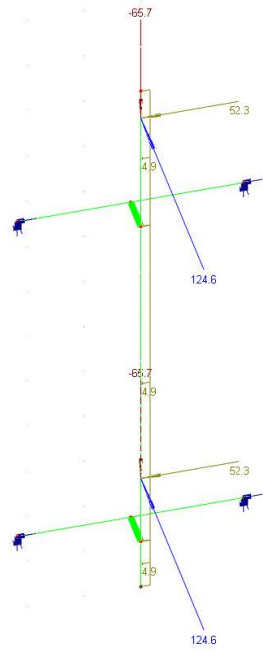

**Note:**

Company/Project: SZS Engineering / 20002-TRN

**VersaFrame V8.11 (608.0)**  
(C) Digital Canal Corp.

Engineer: Sam Gonzalez

Date/Time: 08/04/20 09:45:34

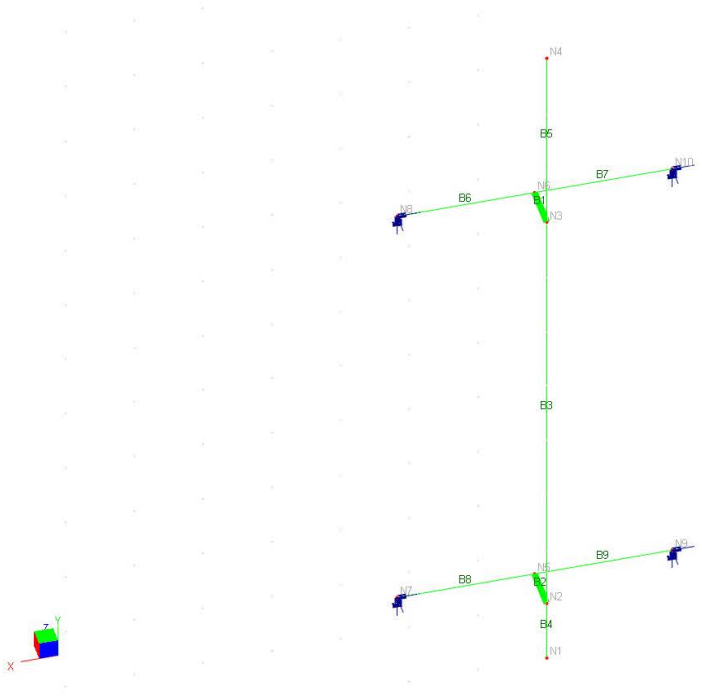

**Note:**

# Steel Check Report

Project:: 20002-TRN  
Description: Antenna Mount  
Date: 08/04/2020 10:10 AM

Company: SZS Engineering  
User: Sam Gonzalez  
Software: Digital Canal VersaFrame

## Code Check Results (LRFD14)

### CRITICAL STRESS SUMMARY

ID	Section Name	Status	Governing Criteria	Stress Ratio	Load Combination	Distance (ft)
3	Pipe2-1/2STD	OK	Axial-Bending	0.0628	TIA-222-G-2.3.1_180	0.0000
4	Pipe2-1/2STD	OK	Axial-Bending	0.0003	TIA-222-G-2.3.1_270	0.0000
5	Pipe2-1/2STD	OK	Axial-Bending	0.0737	TIA-222-G-2.3.1_210	0.0000
6	L3X3X3/8	OK	Axial-Bending	0.0338	TIA-222-G-2.3.1_30	1.0000
7	L3X3X3/8	OK	Axial-Bending	0.0338	TIA-222-G-2.3.1_330	0.0000
8	L3X3X3/8	OK	Axial-Bending	0.0232	TIA-222-G-2.3.1_150	1.0000
9	L3X3X3/8	OK	Axial-Bending	0.0232	TIA-222-G-2.3.1_210	0.0000

### SELECTED LOAD COMBINATIONS

Load Combination	Code Check	Total	Live	Dependent	Conditional
TIA-222-G-2.3.1_0	x			-	-
TIA-222-G-2.3.1_30	x			-	-
TIA-222-G-2.3.1_60	x			-	-
TIA-222-G-2.3.1_90	x			-	-
TIA-222-G-2.3.1_120	x			-	-
TIA-222-G-2.3.1_150	x			-	-
TIA-222-G-2.3.1_180	x			-	-
TIA-222-G-2.3.1_210	x			-	-
TIA-222-G-2.3.1_240	x			-	-
TIA-222-G-2.3.1_270	x			-	-
TIA-222-G-2.3.1_300	x			-	-
TIA-222-G-2.3.1_330	x			-	-



	Node Id	Rx [lb]	Ry [lb]	Rz [lb]	Rox [lb-in]	Roy [lb-in]	Roz [lb-in]
1	11	0.000	227.712	-249.200	-2183.796	0.000	-0.000
2	<b>Sum</b>	0.000	227.712	-249.200	-2183.796	0.000	-0.000

## INPUT Contents

- General:
- Geometry: [[Nodes](#)] [[Supports](#)]
- Loads: [[Point Loads](#)] [[Line Loads](#)]

## OUTPUT Contents

- Nodal: [[Support Reactions](#)]
  - Members:
-

## Nodes

Units: Coordinates X, Y, Z [in]

No.	X	Y	Z	No.	X	Y	Z
1	0.00	0.00	0.00	2	0.00	6.00	0.00
3	0.00	48.00	0.00	4	0.00	66.00	0.00
5	0.00	6.00	4.00	6	0.00	48.00	4.00
7	12.00	6.00	4.00	8	12.00	48.00	4.00
9	-12.00	6.00	4.00	10	-12.00	48.00	4.00

## Supports

Units: Forced Displacements Dx, Dy, Dz [in]; Dox, Doy, Doz [rad]

Node	Flag	Dx	Dy	Dz	Dox	Doy	Doz
7	111011	0.000	0.000	0.000	0.000	0.000	0.000
8	111011	0.000	0.000	0.000	0.000	0.000	0.000
9	111011	0.000	0.000	0.000	0.000	0.000	0.000
10	111011	0.000	0.000	0.000	0.000	0.000	0.000

## Point Loads

Units: Force [lb]; Moment [lb-in]; Coord-Sys: Local=0, Global=1;  
Direction: 0=X, 1=Y, 2=Z, 3=OX, 4=OY, 5=OZ

\*\*\*\*\* LOAD CASE - [ Dead ]\*\*\*\*\*

Member	Coord-Sys	Direction	Value	Distance
3	1	1	-65.700	0.8
5	1	1	-65.700	0.8

\*\*\*\*\* LOAD CASE - [ Wind ]\*\*\*\*\*

Member	Coord-Sys	Direction	Value	Distance
3	1	2	124.600	0.8
5	1	2	124.600	0.8

\*\*\*\*\* LOAD CASE - [ WindTransverse ]\*\*\*\*\*

Member	Coord-Sys	Direction	Value	Distance
3	1	0	52.300	0.8
5	1	0	52.300	0.8

## Line Loads

Units: Force [lb/ft]; Coord-Sys: Local=0, Global=1; Direction: 0=X, 1=Y, 2=Z

\*\*\*\*\* LOAD CASE - [ WindTransverse ]\*\*\*\*\*

Member	Coord-Sys	Direction	Value1	Value2	Distance1	Distance2
3	1	0	4.900	4.900	0	1
4	1	0	4.900	4.900	0	1
5	1	0	4.900	4.900	0	1

## Support Reactions

Units: Force Reactions Rx, Ry, Rz [lb]; Moment Reactions Rox, Roy, Roz [lb-in]

Load Combination 14: TIA-222-G-2.3.1 0 ALLOWABLE

Node	Rx	Ry	Rz	Rox	Roy	Roz
7	-0.000	8.025	-37.680	0.000	-226.081	-30.951
8	0.000	105.831	-86.920	0.000	-521.519	-617.791
9	-0.000	8.025	-37.680	0.000	226.081	30.951
10	0.000	105.831	-86.920	0.000	521.519	617.791

Load Combination 15: TIA-222-G-2.3.1 30 ALLOWABLE

Node	Rx	Ry	Rz	Rox	Roy	Roz
------	----	----	----	-----	-----	-----

7	-13.572	22.901	-40.713	0.000	-230.582	-103.445
8	-19.316	118.197	-83.634	0.000	-482.615	-654.263
9	-13.572	6.139	-27.017	0.000	175.797	36.399
10	-19.316	80.476	-64.443	0.000	405.849	503.378

## Load Combination 16: TIA-222-G-2.3.1 60 ALLOWABLE

Node	Rx	Ry	Rz	Rox	Roy	Roz
7	-23.506	46.775	-35.305	0.000	-188.107	-234.421
8	-33.455	114.263	-55.476	0.000	-299.616	-603.051
9	-23.506	17.744	-11.583	0.000	93.219	118.297
10	-33.455	48.931	-22.237	0.000	166.659	341.717

## Load Combination 17: TIA-222-G-2.3.1 90 ALLOWABLE

Node	Rx	Ry	Rz	Rox	Roy	Roz
7	-27.143	73.253	-22.903	0.000	-110.023	-388.798
8	-38.632	95.086	-9.985	0.000	-21.527	-477.877
9	-27.143	39.730	4.490	0.000	0.452	254.707
10	-38.632	19.643	28.397	0.000	-132.002	176.104

## Load Combination 18: TIA-222-G-2.3.1 120 ALLOWABLE

Node	Rx	Ry	Rz	Rox	Roy	Roz
7	-23.506	95.237	-6.829	0.000	-17.249	-525.194
8	-33.455	65.802	40.648	0.000	277.127	-312.279
9	-23.506	66.207	16.894	0.000	-77.639	409.071
10	-33.455	0.468	73.887	0.000	-410.082	50.941

## Load Combination 19: TIA-222-G-2.3.1 150 ALLOWABLE

Node	Rx	Ry	Rz	Rox	Roy	Roz
7	-13.572	106.837	8.608	0.000	65.343	-607.065
8	-19.316	34.261	82.852	0.000	516.304	-150.645
9	-13.572	90.076	22.304	0.000	-120.129	540.019
10	-19.316	-3.461	102.043	0.000	-593.067	-0.244

## Load Combination 20: TIA-222-G-2.3.1 180 ALLOWABLE

Node	Rx	Ry	Rz	Rox	Roy	Roz
7	-0.000	104.949	19.272	0.000	115.635	-612.499
8	0.000	8.907	105.328	0.000	631.965	-36.243
9	-0.000	104.949	19.272	0.000	-115.635	612.499
10	0.000	8.907	105.328	0.000	-631.965	36.243

## Load Combination 21: TIA-222-G-2.3.1 210 ALLOWABLE

Node	Rx	Ry	Rz	Rox	Roy	Roz
7	13.572	90.076	22.304	0.000	120.129	-540.019
8	19.316	-3.461	102.043	0.000	593.067	0.244
9	13.572	106.837	8.608	0.000	-65.343	607.065
10	19.316	34.261	82.852	0.000	-516.304	150.645

## Load Combination 22: TIA-222-G-2.3.1 240 ALLOWABLE

Node	Rx	Ry	Rz	Rox	Roy	Roz
7	23.506	66.207	16.894	0.000	77.639	-409.071
8	33.455	0.468	73.887	0.000	410.082	-50.941
9	23.506	95.237	-6.829	0.000	17.249	525.194
10	33.455	65.802	40.648	0.000	-277.127	312.279

## Load Combination 23: TIA-222-G-2.3.1 270 ALLOWABLE

Node	Rx	Ry	Rz	Rox	Roy	Roz
7	27.143	39.730	4.490	0.000	-0.452	-254.707
8	38.632	19.643	28.397	0.000	132.002	-176.104
9	27.143	73.253	-22.903	0.000	110.023	388.798
10	38.632	95.086	-9.985	0.000	21.527	477.877

## Load Combination 24: TIA-222-G-2.3.1 300 ALLOWABLE

Node	Rx	Ry	Rz	Rox	Roy	Roz
7	23.506	17.744	-11.583	0.000	-93.219	-118.297
8	33.455	48.931	-22.237	0.000	-166.659	-341.717
9	23.506	46.775	-35.305	0.000	188.107	234.421
10	33.455	114.263	-55.476	0.000	299.616	603.051

Load Combination 25: TIA-222-G-2.3.1 330 ALLOWABLE

Node	R <sub>x</sub>	R <sub>y</sub>	R <sub>z</sub>	R <sub>ox</sub>	R <sub>oy</sub>	R <sub>oz</sub>
7	13.572	6.139	-27.017	0.000	-175.797	-36.399
8	19.316	80.476	-64.443	0.000	-405.849	-503.378
9	13.572	22.901	-40.713	0.000	230.582	103.445
10	19.316	118.197	-83.634	0.000	482.615	654.263

Company/Project: SZS Engineering / 20002-TRN

**VersaFrame V8.11 (608.0)**  
(C) Digital Canal Corp.

Engineer: Sam Gonzalez

Date/Time: 08/04/20 09:36:18

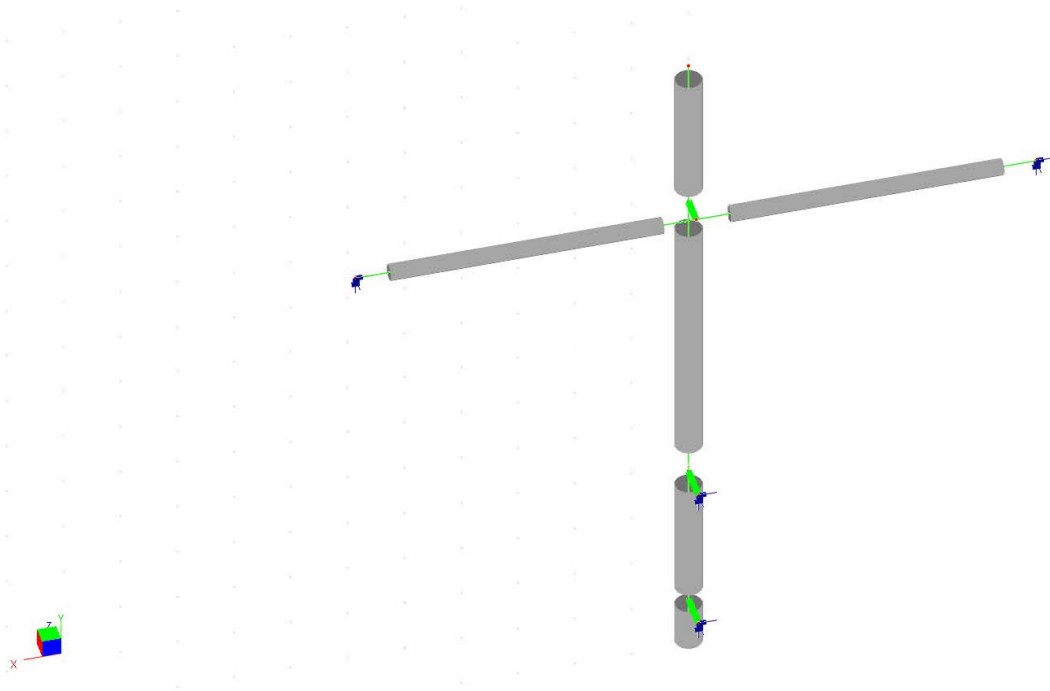

**Note:**

Company/Project: SZS Engineering / 20002-TRN

**VersaFrame V8.11 (608.0)**  
(C) Digital Canal Corp.

Engineer: Sam Gonzalez

Date/Time: 08/04/20 09:43:16

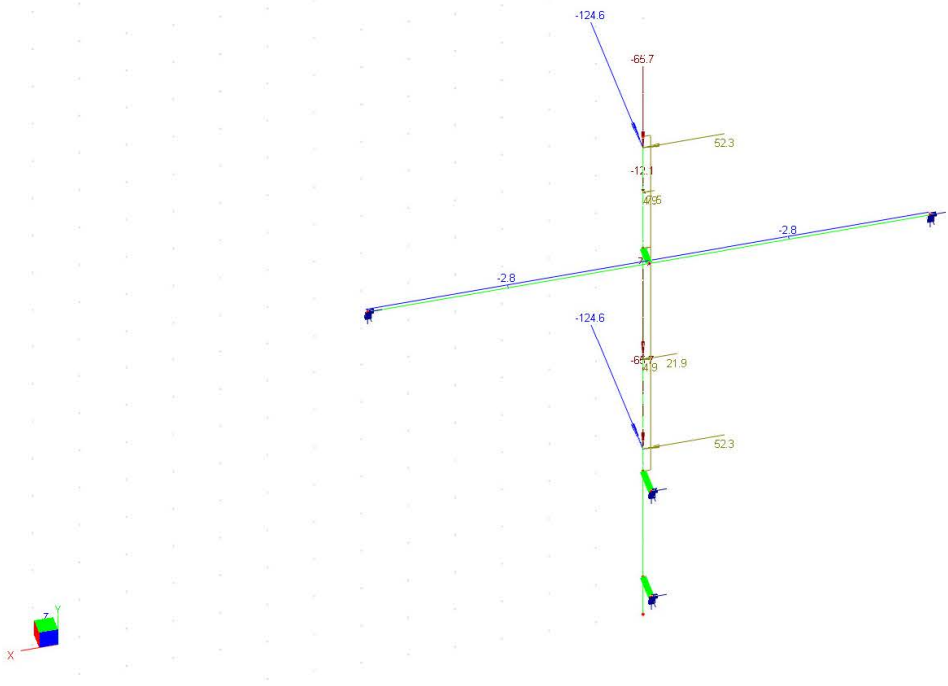

**Note:**

Company/Project: SZS Engineering / 20002-TRN

**VersaFrame V8.11 (608.0)**  
(C) Digital Canal Corp.

Engineer: Sam Gonzalez

Date/Time: 08/04/20 09:37:25

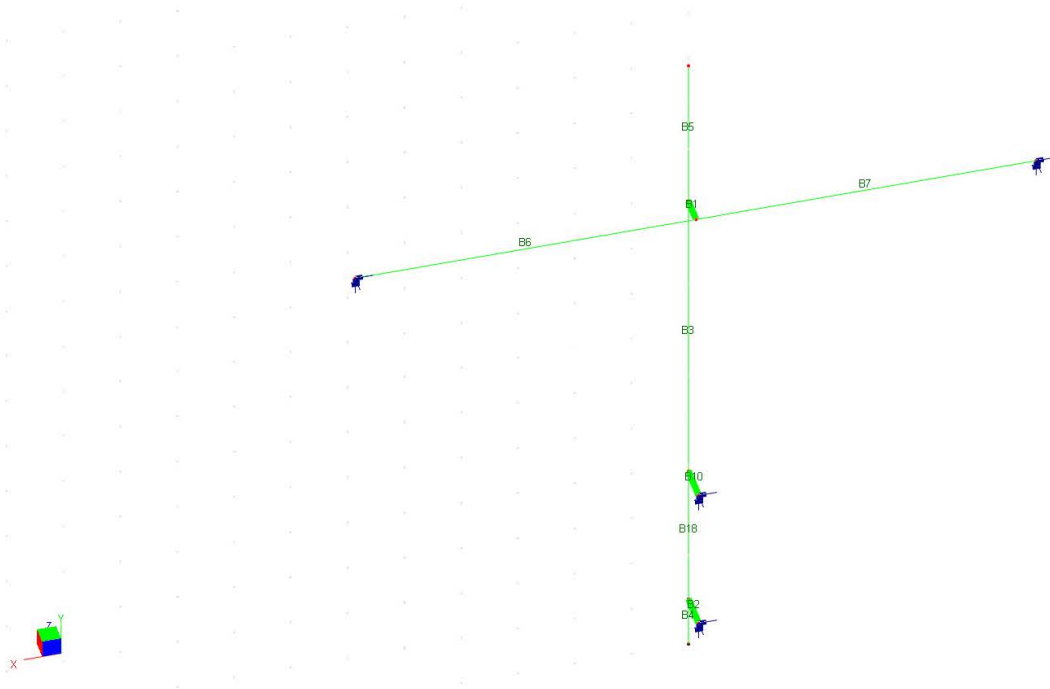

**Note:**



Company/Project: SZS Engineering / 20002-TRN

**VersaFrame V8.11 (608.0)**  
(C) Digital Canal Corp.

Engineer: Sam Gonzalez

Date/Time: 08/04/20 09:36:56

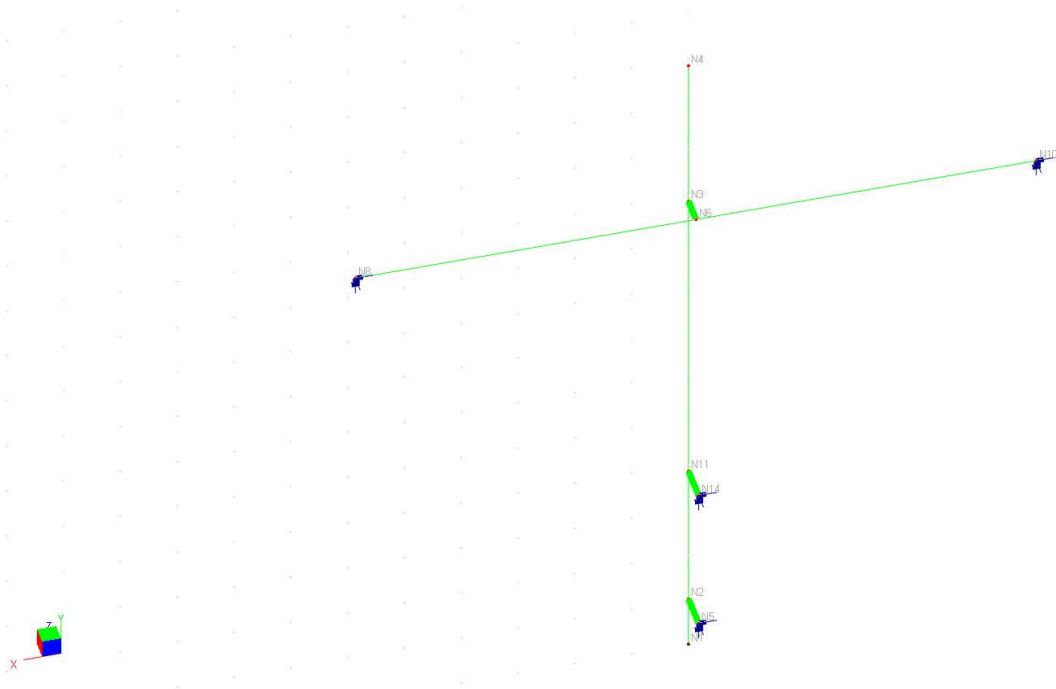

**Note:**

# Steel Check Report

Project:: 20002-TRN  
 Description: Antenna Mount  
 Date: 08/04/2020 09:43 AM

Company: SZS Engineering  
 User: Sam Gonzalez  
 Software: Digital Canal VersaFrame

## Code Check Results (LRFD14)

### CRITICAL STRESS SUMMARY

ID	Section Name	Status	Governing Criteria	Stress Ratio	Load Combination	Distance (ft)
3	Pipe2-1/2STD	OK	Axial-Bending	0.1184	TIA-222-G-2.3.1_0	3.0000
4	Pipe2-1/2STD	OK	Axial-Bending	0.0000	TIA-222-G-2.3.1_180	0.0000
5	Pipe2-1/2STD	OK	Axial-Bending	0.0841	TIA-222-G-2.3.1_330	0.0000
6	Pipe1-1/4STD	OK	Axial-Bending	0.2027	TIA-222-G-2.3.1_0	0.0000
7	Pipe1-1/4STD	OK	Axial-Bending	0.2027	TIA-222-G-2.3.1_0	3.0000
18	Pipe2-1/2STD	OK	Axial-Bending	0.0824	TIA-222-G-2.3.1_180	0.0000

### SELECTED LOAD COMBINATIONS

Load Combination	Code Check	Total	Live	Dependent	Conditional
TIA-222-G-2.3.1_0	x			-	-
TIA-222-G-2.3.1_30	x			-	-
TIA-222-G-2.3.1_60	x			-	-
TIA-222-G-2.3.1_90	x			-	-
TIA-222-G-2.3.1_120	x			-	-
TIA-222-G-2.3.1_150	x			-	-
TIA-222-G-2.3.1_180	x			-	-
TIA-222-G-2.3.1_210	x			-	-
TIA-222-G-2.3.1_240	x			-	-
TIA-222-G-2.3.1_270	x			-	-
TIA-222-G-2.3.1_300	x			-	-
TIA-222-G-2.3.1_330	x			-	-

## INPUT Contents

- General:
- Geometry: [[Nodes](#)] [[Supports](#)]
- Loads: [[Point Loads](#)] [[Line Loads](#)]

## OUTPUT Contents

- Nodal: [[Support Reactions](#)]
  - Members:
-

## Nodes

Units: Coordinates X, Y, Z [in]

No.	X	Y	Z	No.	X	Y	Z
1	0.00	0.00	0.00	2	0.00	6.00	0.00
3	0.00	59.00	0.00	4	0.00	77.00	0.00
5	0.00	6.00	-4.00	6	0.00	59.00	-3.00
8	36.00	59.00	-3.00	10	-36.00	59.00	-3.00
11	0.00	23.00	0.00	14	0.00	23.00	-4.00

## Supports

Units: Forced Displacements Dx, Dy, Dz [in]; Dox, Doy, Doz [rad]

Node	Flag	Dx	Dy	Dz	Dox	Doy	Doz
5	111011	0.000	0.000	0.000	0.000	0.000	0.000
8	111011	0.000	0.000	0.000	0.000	0.000	0.000
10	111011	0.000	0.000	0.000	0.000	0.000	0.000
14	111011	0.000	0.000	0.000	0.000	0.000	0.000

## Point Loads

Units: Force [lb]; Moment [lb-in]; Coord-Sys: Local=0, Global=1;  
Direction: 0=X, 1=Y, 2=Z, 3=OX, 4=OY, 5=OZ

\*\*\*\*\* LOAD CASE - [ Dead ]\*\*\*\*\*

Member	Coord-Sys	Direction	Value	Distance
3	1	1	-65.700	0.9
3	1	1	-74.000	0.5
5	1	1	-65.700	0.9
5	1	1	-12.100	0.5

\*\*\*\*\* LOAD CASE - [ Wind ]\*\*\*\*\*

Member	Coord-Sys	Direction	Value	Distance
3	1	2	-124.600	0.9
5	1	2	-124.600	0.9

\*\*\*\*\* LOAD CASE - [ WindTransverse ]\*\*\*\*\*

Member	Coord-Sys	Direction	Value	Distance
3	1	0	52.300	0.9
3	1	0	21.900	0.5
5	1	0	52.300	0.9
5	1	0	7.500	0.5

## Line Loads

Units: Force [lb/ft]; Coord-Sys: Local=0, Global=1; Direction: 0=X, 1=Y, 2=Z

\*\*\*\*\* LOAD CASE - [ Wind ]\*\*\*\*\*

Member	Coord-Sys	Direction	Value1	Value2	Distance1	Distance2
6	1	2	-2.800	-2.800	0	1
7	1	2	-2.800	-2.800	0	1

\*\*\*\*\* LOAD CASE - [ WindTransverse ]\*\*\*\*\*

Member	Coord-Sys	Direction	Value1	Value2	Distance1	Distance2
3	1	0	4.900	4.900	0	1
5	1	0	4.900	4.900	0	1

## Support Reactions

Units: Force Reactions Rx, Ry, Rz [lb]; Moment Reactions Rox, Roy, Roz [lb-in]

Load Combination 2: TIA-222-G-2.3.1 0

Node	Rx	Ry	Rz	Rox	Roy	Roz
5	-0.000	-454.518	-226.283	0.000	-0.000	0.000
8	-0.000	16.989	98.207	0.000	1687.092	-260.322
10	0.000	16.989	98.207	0.000	-1687.092	260.322
14	0.000	738.277	455.469	0.000	0.000	-0.000

Load Combination 3: TIA-222-G-2.3.1 30

Node	Rx	Ry	Rz	Rox	Roy	Roz
5	0.000	-375.294	-186.879	0.000	-0.000	-0.000
8	-44.655	18.429	88.032	0.000	1496.919	-267.457
10	-44.655	12.126	81.829	0.000	-1420.943	191.605
14	-35.530	662.476	385.598	0.000	-257.640	29.672

Load Combination 4: TIA-222-G-2.3.1 60

Node	Rx	Ry	Rz	Rox	Roy	Roz
5	0.000	-158.854	-79.224	0.000	-0.000	-0.000
8	-77.345	16.068	54.089	0.000	901.513	-211.116
10	-77.346	5.136	43.228	0.000	-769.657	79.699
14	-61.539	455.387	194.707	0.000	-446.060	51.336

Load Combination 5: TIA-222-G-2.3.1 90

Node	Rx	Ry	Rz	Rox	Roy	Roz
5	0.000	136.798	67.836	0.000	-0.000	-0.000
8	-89.311	10.541	5.474	0.000	60.413	-106.397
10	-89.312	-2.108	-7.251	0.000	92.254	-45.408
14	-71.057	172.505	-66.059	0.000	-514.773	59.189

Load Combination 6: TIA-222-G-2.3.1 120

Node	Rx	Ry	Rz	Rox	Roy	Roz
5	0.000	432.438	214.897	0.000	-0.000	-0.000
8	-77.347	3.322	-44.843	0.000	-801.137	18.661
10	-77.347	-7.654	-56.023	0.000	933.707	-150.177
14	-61.535	-110.369	-326.831	0.000	-445.553	51.182

Load Combination 7: TIA-222-G-2.3.1 150

Node	Rx	Ry	Rz	Rox	Roy	Roz
5	0.000	648.853	322.554	0.000	-0.000	-0.000
8	-44.657	-3.664	-83.440	0.000	-1452.416	130.564
10	-44.657	-10.011	-89.962	0.000	1529.107	-206.516
14	-35.527	-317.441	-517.732	0.000	-257.134	29.517

Load Combination 8: TIA-222-G-2.3.1 180

Node	Rx	Ry	Rz	Rox	Roy	Roz
5	0.000	728.066	361.959	0.000	0.000	-0.000
8	-0.000	-8.547	-99.976	0.000	-1718.920	199.331
10	0.000	-8.547	-99.976	0.000	1718.920	-199.331
14	0.000	-393.234	-587.608	0.000	0.000	-0.000

Load Combination 9: TIA-222-G-2.3.1 210

Node	Rx	Ry	Rz	Rox	Roy	Roz
5	-0.000	648.853	322.554	0.000	0.000	0.000
8	44.657	-10.011	-89.962	0.000	-1529.107	206.516
10	44.657	-3.664	-83.440	0.000	1452.416	-130.564
14	35.527	-317.441	-517.732	0.000	257.134	-29.517

Load Combination 10: TIA-222-G-2.3.1 240

Node	Rx	Ry	Rz	Rox	Roy	Roz
5	-0.000	432.438	214.897	0.000	0.000	0.000
8	77.347	-7.654	-56.023	0.000	-933.707	150.177
10	77.347	3.322	-44.843	0.000	801.137	-18.661
14	61.535	-110.369	-326.831	0.000	445.553	-51.182

Load Combination 11: TIA-222-G-2.3.1 270

Node	Rx	Ry	Rz	Rox	Roy	Roz
5	-0.000	136.798	67.836	0.000	0.000	0.000
8	89.312	-2.108	-7.251	0.000	-92.254	45.408
10	89.311	10.541	5.474	0.000	-60.413	106.397
14	71.057	172.505	-66.059	0.000	514.773	-59.189

Load Combination 12: TIA-222-G-2.3.1 300

Node	Rx	Ry	Rz	Rox	Roy	Roz
5	-0.000	-158.854	-79.224	0.000	0.000	0.000
8	77.346	5.136	43.228	0.000	769.657	-79.699
10	77.345	16.068	54.089	0.000	-901.513	211.116
14	61.539	455.387	194.707	0.000	446.060	-51.336

Load Combination 13: TIA-222-G-2.3.1 330

Node	Rx	Ry	Rz	Rox	Roy	Roz
5	-0.000	-375.294	-186.879	0.000	0.000	0.000
8	44.655	12.126	81.829	0.000	1420.943	-191.605
10	44.655	18.429	88.032	0.000	-1496.919	267.457
14	35.530	662.476	385.598	0.000	257.640	-29.672

**Search Information**

**Address:** 1925 Massachusetts Ave, Cambridge, MA 02140, USA  
**Coordinates:** 42.3894663, -71.11973300000001  
**Elevation:** 37 ft  
**Timestamp:** 2020-08-04T15:29:24.434Z  
**Hazard Type:** Wind



**ASCE 7-16**

MRI 10-Year ..... 75 mph  
 MRI 25-Year ..... 84 mph  
 MRI 50-Year ..... 91 mph  
 MRI 100-Year ..... 98 mph  
 Risk Category I ..... 109 mph  
 Risk Category II ..... 119 mph  
 Risk Category III ..... 128 mph  
 Risk Category IV ..... ⚠️ 132 mph

You are in a wind-borne debris region if you are also within 1 mile of the coastal mean high water line.

**ASCE 7-10**

MRI 10-Year ..... 78 mph  
 MRI 25-Year ..... 88 mph  
 MRI 50-Year ..... 96 mph  
 MRI 100-Year ..... 103 mph  
 Risk Category I ..... 117 mph  
 Risk Category II ..... 127 mph  
 Risk Category III-IV ... ⚠️ 138 mph

If the structure under consideration is a healthcare facility and you are also within 1 mile of the coastal mean high water line, you are in a wind-borne debris region. If other occupancy, use the Risk Category II basic wind speed contours to determine if you are in a wind-borne debris region.

**ASCE 7-05**

ASCE 7-05 Wind Speed ..... 104 mph

*The results indicated here DO NOT reflect any state or local amendments to the values or any delineation lines made during the building code adoption process. Users should confirm any output obtained from this tool with the local Authority Having Jurisdiction before proceeding with design.*

**Disclaimer**

Hazard loads are interpolated from data provided in ASCE 7 and rounded up to the nearest whole integer. Per ASCE 7, islands and coastal areas outside the last contour should use the last wind speed contour of the coastal area – in some cases, this website will extrapolate past the last wind speed contour and therefore, provide a wind speed that is slightly higher. NOTE: For queries near wind-borne debris region boundaries, the resulting determination is sensitive to rounding which may affect whether or not it is considered to be within a wind-borne debris region.

Mountainous terrain, gorges, ocean promontories, and special wind regions shall be examined for unusual wind conditions.

1923 Mass Ave

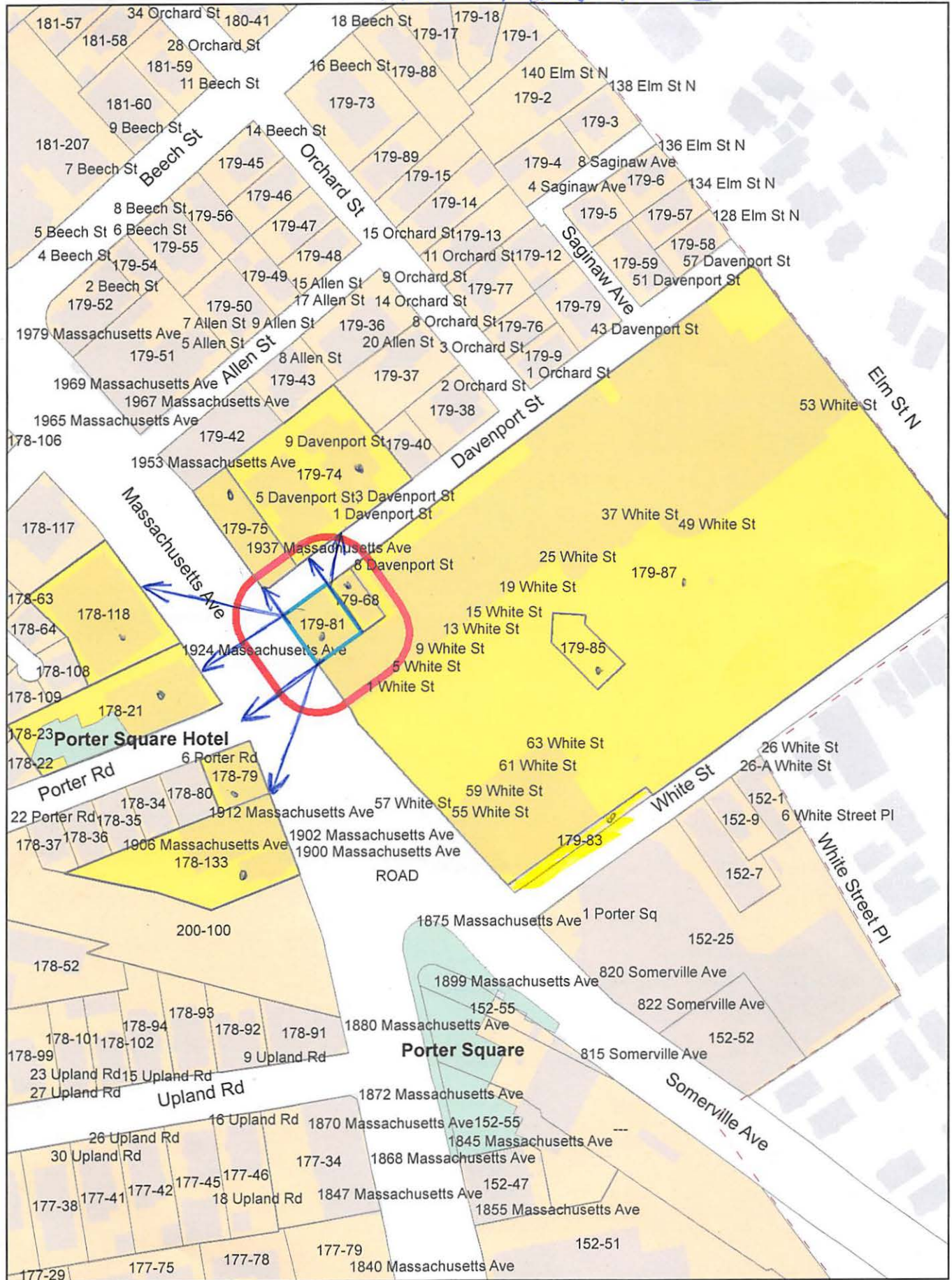



1923 Mass Ave

Petitioner

179-75  
BOYER, BURTON  
TRUSTEE OF LISA II REALTY TRUST  
P.O. BOX 67398  
CHESTNUT HILL, MA 02467

179-85-83  
MASSACHUSETTS BAY TRANSPORTATION  
AUTHORITY  
10 PARK PLAZA  
BOSTON, MA 02116

JAKE SHAPPY  
10 INDUSTRIAL AVE – SUITE 3  
MAHWAH, NJ 07430

179-74  
DAVENPORT STREET, LLC  
75 RIVER STREET  
CAMBRIDGE, MA 02139

179-74  
REESE, REGINALD P., JR. &  
MARIE T. MURPHY REESE  
1-15 DAVENPORT ST UNIT 12  
CAMBRIDGE, MA 02140

179-81  
1925 MASS AVE, LLC.  
C/O ERIC HOAGLAND  
195 LEXINGTON AVE.  
CAMBRIDGE, MA 02138

178-21  
PORTER SQUARE HOTEL, LLC  
1924 MASS AVE  
CAMBRIDGE, MA 02140

178-79  
TOADMAN, LLC  
1920 MASSACHUSETTS AVE  
CAMBRIDGE, MA 02140

178-118  
CAMBRIDGE MASONIC HALL ASSOCIATION  
1950 MASS AVE  
CAMBRIDGE, MA 02140

179-87  
PORTER SQUARE LLC  
C/O GRAVESTAR, INC.  
160 SECOND ST  
CAMBRIDGE, MA 02142

179-74  
GREGORY, STEVEN, MARY KATHRYN BRATUN &  
CITY OF CAMBRIDGE TAX TITLE  
141 FEDERAL STREET  
SALEM, MA 01970

179-74  
KULSHRESTHA, ANKIT  
15 DAVENPORT ST., #8/1  
CAMBRIDGE, MA 02140

179-74  
JEFFERSON, MARILYN W. &  
PHILIP O. JEFFERSON, TRS  
1-15 DAVENPORT ST., #9/1  
CAMBRIDGE, MA 02140

178-133  
PKH PROPERTIES, LLC  
P.O. BOX 621 BROOKLINE  
BROOKLINE, MA 02446

179-74  
GREGORY, STEVEN K. , MARY KATHRYN BRATUN  
& CITY OF CAMBRIDGE TAX TITLE  
141 FEDERAL STREET  
SALEM, MA 01970

179-74  
HUANG, HON-REN & YU-HSIN CHIU  
15 GOFFE ROAD  
LEXINGTON, MA 02421

179-74  
LEE, CHOONG I. & BYUNG SOOK LEE KIM  
1 DAVENPORT ST UNIT 10  
CAMBRIDGE, MA 02140

179-74  
LIN, LENNOX  
1-15 DAVENPORT ST UNIT 6  
CAMBRIDGE, MA 02140

179-74  
KUO, BOBBY F  
179 LARCH RD, APT #2  
CAMBRIDGE, MA 02138

179-68  
8 DAVENPORT LLC.  
195 LEXINGTON AVE  
CAMBRIDGE, MA 02138

179-74  
PORTER, JOHN MIKAEL &  
ADIA ALEXANDRA PORTER  
1 DAVENPORT ST UNIT #5  
CAMBRIDGE, MA 02140

179-74  
MORSE, STEPHEN P. STEPHEN P. MORSE  
DECLARATION OF TRUST  
1 DAVENPORT ST UNIT 11  
CAMBRIDGE, MA 02140

179-74  
SENGUPTA RITA SENGUPTA HIRAK ET AL  
3 DAVENPORT ST #3  
CAMBRIDGE, MA 02140

**BZA APPLICATION FORM - OWNERSHIP INFORMATION**

To be completed by OWNER, signed before a notary and returned to The Secretary of the Board of Zoning Appeals.

I/We 1925 Mass Ave, LLC - Eric Hoagland, Manager  
(OWNER)

Address: 195 Lexington Avenue, Cambridge, MA

State that I/We own the property located at 1923-1925 MASS AVE, Cambridge which is the subject of this zoning application.

The record title of this property is in the name of \_\_\_\_\_  
1925 MASS AVE LLC

\*Pursuant to a deed of duly recorded in the date 8-10-11, Middlesex South County Registry of Deeds at Book 57277, Page 496; or Middlesex Registry District of Land Court, Certificate No. \_\_\_\_\_

Book \_\_\_\_\_ Page \_\_\_\_\_

Eric W. Hoagland, mgr.  
SIGNATURE BY LAND OWNER OR AUTHORIZED TRUSTEE, OFFICER OR AGENT\*

\*Written evidence of Agent's standing to represent petitioner may be requested.

Commonwealth of Massachusetts, County of Suffolk

The above-name Eric Hoagland personally appeared before me, this 22<sup>nd</sup> of July, 2021, and made oath that the above statement is true.

[Signature] Notary

My commission expires \_\_\_\_\_ (Notary Seal).

- If ownership is not shown in recorded deed, e.g. if by court order, recent deed, or inheritance, please include documentation.



*[Faint, illegible handwritten text, possibly bleed-through from the reverse side of the page.]*





2011 00138457

Bk: 57277 Pg: 496 Doc: DEED  
Page: 1 of 2 09/10/2011 02:25 PM

**QUITCLAIM DEED**

*fr*

*Address: 1925 Massachusetts Ave. Cambridge, MA.*

The undersigned Charles R. Laverty, Jr. and Paul R. Lohnes, of 75 Cambridge Parkway, Suite 100, Cambridge, Massachusetts 02141 ("Grantors"), for consideration paid of Five Million and Twenty-five Thousand Dollars (\$5,025,000.00), grant to 1925 Mass Ave, LLC, a Massachusetts Limited Liability Company with a principal office located at 195 Lexington Avenue, Cambridge, Massachusetts 02138 ("Grantee"),

With Quitclaim Covenants,

A certain parcel of land with the buildings thereon, situated in that part of Cambridge called North Cambridge, being shown as Lot B on a plan entitled "Plan of Premises in North Cambridge belonging to Helena V. Wilder", by W.A. Mason & Son, Surveyors, recorded in the Middlesex County South District Registry of Deeds at the end of Book 3076.

Beginning at the Southeasterly corner thereof; thence turning

NORTHEASTERLY: by land now or formerly of James H. Cutter, 60.01 feet; thence turning and running

NORTHWESTERLY: by a line parallel to Massachusetts Avenue, formerly called North Avenue, to land held formerly in common by Cutter heirs, now Davenport Street, 63.59 feet, thence turning and running

SOUHWESTERLY: by Davenport Street, 60.06 feet; thence turning and running

SOUTHEASTERLY: by said Massachusetts Avenue, 62.97 feet to the point of beginning.

Excepted from the foregoing is approximately eighteen (18) square feet of land referred to in a certain deed from Lazar D. Nasson to Stephen P. Mugar, Trustee dated June 6, 1957 and recorded at Middlesex Deeds Book 8981, page 158. See also confirmatory deed recorded at book 9073, page 116.

The premises are conveyed subject to the provisions of the local zoning laws; to existing rights created by instruments of record in party or partition walls, if any, and to outstanding leases, of record, if any.

For Grantors' title see Deed dated April 12, 1984, and recorded with the Middlesex County South District Registry of Deeds in Book 15522, Page 241.

MASSACHUSETTS EXCISE TAX  
Southern Middlesex District ROD # 001  
Date: 09/10/2011 02:25 PM  
Citr# 167507 13772 Doc# 00138457  
Fee: \$22,914.00 Cons: \$5,025,000.00

Gerard Fong, Esq.  
Fong & Kaston, LLP  
24 School Street  
Suite 720  
Boston, MA 02108

Executed under seal this 4<sup>th</sup> day of August, 2011.

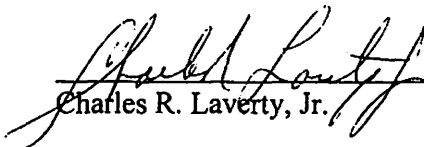
  
\_\_\_\_\_  
Charles R. Lavery, Jr.

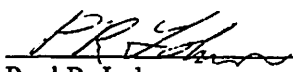
  
\_\_\_\_\_  
Paul R. Lohnes

**COMMONWEALTH OF MASSACHUSETTS**

Middlesex, ss.

On this 4<sup>th</sup> day of August, 2011, before me, the undersigned notary public, personally appeared **Charles R. Lavery, Jr.**, personally known to me and proved to me through satisfactory evidence of identification, which was a Massachusetts driver's license, to be the person whose name is signed upon the preceding or attached document, and acknowledged to me that he signed said Quitclaim Deed voluntarily for its stated purpose.

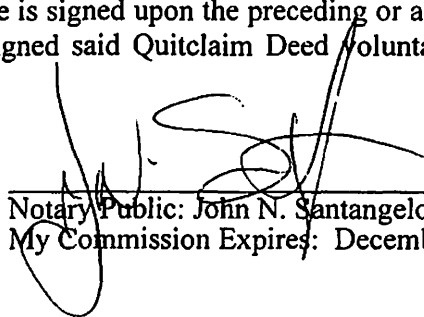
  
\_\_\_\_\_  
Notary Public: John N. Santangelo  
My Commission Expires: December 8, 2017

**COMMONWEALTH OF MASSACHUSETTS**

Middlesex, ss.

On this 4<sup>th</sup> day of August, 2011, before me, the undersigned notary public, personally appeared **Paul R. Lohnes**, personally known to me and proved to me through satisfactory evidence of identification, which was a Massachusetts driver's license, to be the person whose name is signed upon the preceding or attached document, and acknowledged to me that he signed said Quitclaim Deed voluntarily for its stated purpose.

  
\_\_\_\_\_  
Notary Public: John N. Santangelo  
My Commission Expires: December 8, 2017

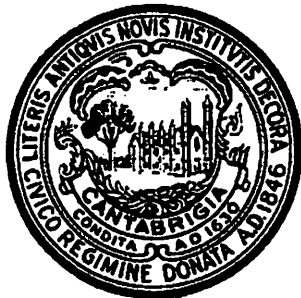

CITY OF CAMBRIDGE, MASSACHUSETTS

# PLANNING BOARD

CITY HALL ANNEX, 344 BROADWAY, CAMBRIDGE, MA 02139

August 18, 2021

To: The Board of Zoning Appeal

From: The Planning Board

RE: BZA-102207 1923 Massachusetts Avenue

The Planning Board reviewed this BZA application during a meeting on August 17, 2021 and decided to forward the following comments to BZA.

The Board does not recommend approval of the proposed modification of the telecommunications facility due to concerns noted in the attached memo from the Community Development Department (CDD). The Board recommends that the BZA continue the hearing to allow the applicant to revise the proposal to respond to the comments and suggestions provided in the CDD memo.



---

**CITY OF CAMBRIDGE**  
Community Development Department

---

**IRAM FAROOQ**  
Assistant City Manager for  
Community Development

**SANDRA CLARKE**  
Deputy Director  
Chief of Administration

**KHALIL MOGASSABI**  
Deputy Director  
Chief of Planning

To: Planning Board

From: Community Development Department (CDD) Staff

Date: August 11, 2021

Re: **Cellular Antenna BZA-102207: 1923 - 1925 Massachusetts Avenue**

The proposal involves modification of the existing wireless antenna installation at 1923-1925 Massachusetts Avenue. Eight (8) existing antennas will be replaced, and four (4) new antennas added, 4 existing remote radio heads (RRHs) will be replaced and 4 new RRHs will be mounted to the rooftop.

The antennas and equipment will be either façade mounted to the side elevations or mounted to the rooftop of the building where existing antennas are installed. The antennas on the Davenport Street elevation and on the side elevation facing the Porter Square Shopping Center are proposed to have a brick pattern appearance like the existing antennas. The rooftop antennas will have a dull, light grey appearance to match the other rooftop equipment.

There is already quite a lot of rooftop equipment and appurtenances installed on this building. The billboard sign and its supporting structure are extremely prominent. The existing antennas are also quite visible, particularly those located on the rooftop. While this is an existing installation, the proposal does add new antennas which increases the visual impacts of the facility. As such, some reorganization and enhanced concealment techniques, which might include a stealth enclosure or screening devices, should be studied. In addition, the existing, façade mounted antennas appear to fit more concisely within the architectural lines of the building and are less noticeable. The proposed new and replacement antennas at the building corners (on Massachusetts Avenue) are larger and seem to encroach upon some of the building's details and above the parapet line.

The following are suggestions to help improve the overall appearance of the installation:

1. To the extent feasible, consider using stealth enclosures or other screening devices set well back on the rooftop, to better conceal the antennas.
2. Since the new and replacement antennas have different dimensions, if feasible, consider utilizing antenna covers on the smaller antennas so that they have the same length as the other antennas.
3. On the side elevation and Davenport Street elevation, the antennas should be relocated to avoid the architectural features of the building. Most notably, this

---

344 Broadway  
Cambridge, MA 02139  
Voice: 617 349-4600  
Fax: 617 349-4669  
TTY: 617 349-4621  
[www.cambridgema.gov](http://www.cambridgema.gov)

---

includes the cream cornices and details at the corners of the building and the parapet line.

4. For the façade mounted antenna on the side elevation and Davenport Street elevation, the proposed brick patterned treatment should be replaced with a uniform, matte color that matches the brick.
5. All visually exposed equipment and materials, including cabling and brackets, should be finished/painted in a matte, dull color.
6. The smallest mounting brackets available should be utilized so that the antennas can be mounted as close to the existing frames and façade surface as possible.
7. The RRHs should be set back as far as possible from the side elevations and Massachusetts Avenue.

Additionally, staff note that the application should include elevation drawings for each side of the building with architectural details shown. Photo simulation # 3 should be revised to show the new and replacement antennas on the Davenport Street elevation. A photo simulation of the Alpha sector antennas located towards the rear of the rooftop should also be provided.





# City of Cambridge

MASSACHUSETTS

BOARD OF ZONING APPEAL

831 Mass Avenue, Cambridge, MA.  
(617) 349-6100

BZA

## POSTING NOTICE – PICK UP SHEET

The undersigned picked up the notice board for the Board of Zoning Appeals Hearing.

Name: MAXWEL SOUZA JR Date: AUG 5  
(Print)

Address: 1923 Mass Ave

Case No. BZA-102207

Hearing Date: 8/19/21

Thank you,  
Bza Members