



CITY OF CAMBRIDGE

BOARD OF ZONING APPEAL

831 Massachusetts Avenue, Cambridge MA 02139

617-349-6100

2023 JAN 12 PM 12:15
OFFICE OF THE CITY CLERK
CAMBRIDGE, MASSACHUSETTS

BZA Application Form

BZA Number: 206407

General Information

The undersigned hereby petitions the Board of Zoning Appeal for the following:

Special Permit: _____ Variance: X Appeal: _____

PETITIONER: Feanil Patel, Kiersten C. Kerby-Patel, Ivy Lee, Blake A. Sessions, Michael O'Brien, Brianna McHorse and David Laibstain C/O Adam Dash, Esq.

PETITIONER'S ADDRESS: 48 Grove Street, Somerville, MA 02144

LOCATION OF PROPERTY: 65 Sparks St, Unit 4, Cambridge, MA

TYPE OF OCCUPANCY: Residential **ZONING DISTRICT:** Residence A-2 Zone

REASON FOR PETITION:

/Dormer/

DESCRIPTION OF PETITIONER'S PROPOSAL:

A dormer is being constructed.

SECTIONS OF ZONING ORDINANCE CITED:

Article: 5.000	Section: 5.31 (Table of Dimensional Requirements)
Article: 8.000	Section: 8.22.3 (Non-Conforming Structure)
Article: 10.000	Section: 10.30 (Variance)

Original
Signature(s):

(Petitioner (s) / Owner)

Feanil Patel, Kiersten C. Kerby-Patel, Ivy Lee, Blake A. Sessions,
Michael O'Brien, Brianna McHorse and David Laibstain, C/O Adam Dash, Esq.

(Print Name)

Address: 48 Grove Street, Suite 304, Somerville, MA 02144
 Tel. No. 617-625-7373
 E-Mail Address: dash@adamdashlaw.com

Date: January 11, 2023

BZA APPLICATION FORM - OWNERSHIP INFORMATION

To be completed by OWNER, signed before a notary and returned to The Secretary of the Board of Zoning Appeals.

I/We Feanil Patel
(OWNER)

Address: 65 Sparks Street, Unit 4, Cambridge, MA 02138

State that I/We own the property located at 65 Sparks Street, Unit 4, Cambridge, MA 02138, which is the subject of this zoning application.

The record title of this property is in the name of _____
Feanil Patel, Kiersten C. Kerby-Patel, Ivy Lee, Blake A. Sessions, Michael O'Brien, BriannaMcHorse and David Laibstain

*Pursuant to a deed of duly recorded in the date 8/3/2021, Middlesex South County Registry of Deeds at Book 78390, Page 525; or Middlesex Registry District of Land Court, Certificate No. _____
Book _____ Page _____

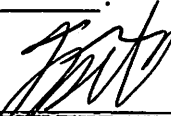

SIGNATURE BY LAND OWNER OR AUTHORIZED TRUSTEE, OFFICER OR AGENT*

**Written evidence of Agent's standing to represent petitioner may be requested.*

Commonwealth of Massachusetts, County of Middlesex

The above-name Feanil Patel personally appeared before me, this 7th of Nov., 2022, and made oath that the above statement is true.



Notary

My commission expires 2/5/2027 (Notary Seal).

- If ownership is not shown in recorded deed, e.g. if by court order, recent deed, or inheritance, please include documentation.

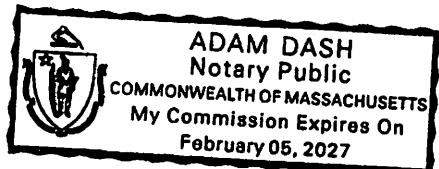

Recd. 1/10/23

[Handwritten signature]

1/10/23

1/10/23

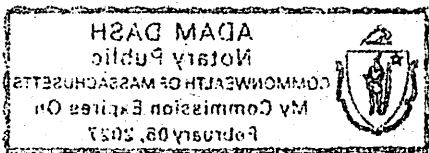

BZA APPLICATION FORM - OWNERSHIP INFORMATION

To be completed by OWNER, signed before a notary and returned to The Secretary of the Board of Zoning Appeals.

I/We Kiersten C. Kerby-Patel
(OWNER)

Address: 65 Sparks Street, Unit 4, Cambridge, MA 02138

State that I/We own the property located at 65 Sparks Street, Unit 4, Cambridge, MA 02138, which is the subject of this zoning application.

The record title of this property is in the name of _____
Feanil Patel, Kiersten C. Kerby-Patel, Ivy Lee, Blake A. Sessions, Michael O'Brien, BriannaMcHorse and David Laibstain

*Pursuant to a deed of duly recorded in the date 8/3/2021, Middlesex South County Registry of Deeds at Book 78390, Page 525; or Middlesex Registry District of Land Court, Certificate No. _____ Book _____ Page _____.

SIGNATURE BY LAND OWNER OR AUTHORIZED TRUSTEE, OFFICER OR AGENT*

*Written evidence of Agent's standing to represent petitioner may be requested.

Commonwealth of Massachusetts, County of Middlesex

The above-name Kiersten C. Kerby-Patel personally appeared before me, this 7th of Nov-, 2022, and made oath that the above statement is true.

 Notary

My commission expires 2/5/2027 (Notary Seal).

- If ownership is not shown in recorded deed, e.g. if by court order, recent deed, or inheritance, please include documentation.

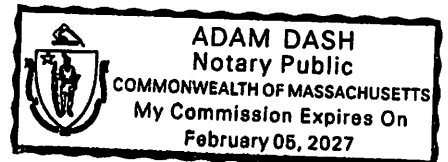

BZA APPLICATION FORM - OWNERSHIP INFORMATION

To be completed by OWNER, signed before a notary and returned to The Secretary of the Board of Zoning Appeals.

I/We Ivy Lee (OWNER)

Address: 65 Sparks Street, Unit 4, Cambridge, MA 02138

State that I/We own the property located at 65 Sparks Street, Unit 4, Cambridge, MA 02138, which is the subject of this zoning application.

The record title of this property is in the name of _____
Feanil Patel, Kiersten C. Kerby-Patel, Ivy Lee, Blake A. Sessions, Michael O'Brien, BriannaMcHorse and David Laibstain

*Pursuant to a deed of duly recorded in the date 8/3/2021, Middlesex South County Registry of Deeds at Book 78390, Page 525; or Middlesex Registry District of Land Court, Certificate No. _____ Book _____ Page _____.

[Signature]
SIGNATURE BY LAND OWNER OR AUTHORIZED TRUSTEE, OFFICER OR AGENT*

*Written evidence of Agent's standing to represent petitioner may be requested.

Commonwealth of Massachusetts, County of Middlesex

The above-name Ivy Lee personally appeared before me, this 4th of November, 2022, and made oath that the above statement is true.

[Signature] Notary

My commission expires Feb. 3, 2028 (Notary Seal).

- If ownership is not shown in recorded deed, e.g. if by court order, recent deed, or inheritance, please include documentation.

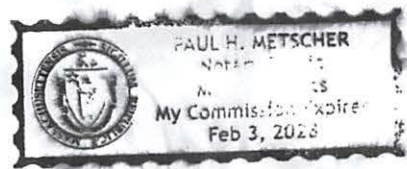
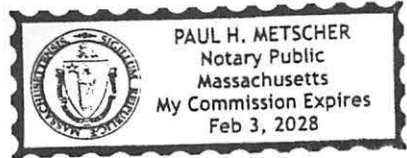

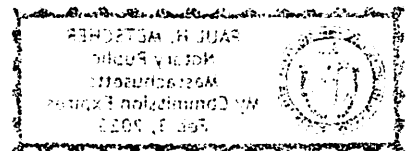
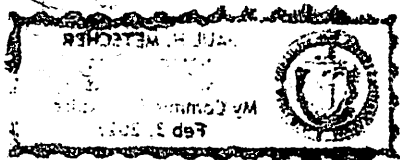

BZA APPLICATION FORM - OWNERSHIP INFORMATION

To be completed by OWNER, signed before a notary and returned to The Secretary of the Board of Zoning Appeals.

I/We Blake Sessions
(OWNER)

Address: 65 Sparks Street, Unit 4, Cambridge, MA 02138

State that I/We own the property located at 65 Sparks Street, Unit 4, Cambridge, MA 02138, which is the subject of this zoning application.

The record title of this property is in the name of _____
Feanil Patel, Kiersten C. Kerby-Patel, Ivy Lee, Blake A. Sessions, Michael O'Brien, BriannaMcHorse and David Laibstain

*Pursuant to a deed of duly recorded in the date 8/3/2021, Middlesex South County Registry of Deeds at Book 78390, Page 525; or Middlesex Registry District of Land Court, Certificate No. _____
Book _____ Page _____.

SIGNATURE BY LAND OWNER OR AUTHORIZED TRUSTEE, OFFICER OR AGENT*

*Written evidence of Agent's standing to represent petitioner may be requested.

Commonwealth of Massachusetts, County of Middlesex

The above-name Blake Sessions personally appeared before me, this 9th of November, 2022, and made oath that the above statement is true.

Paul H. Metscher Notary

My commission expires Feb. 3, 2028 (Notary Seal).

- If ownership is not shown in recorded deed, e.g. if by court order, recent deed, or inheritance, please include documentation.

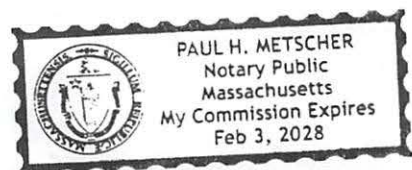

PAUL H. WETZCHER
Notary Public
Massachusetts
My Commission Expires
Feb 3, 2028



BZA APPLICATION FORM - OWNERSHIP INFORMATION

To be completed by OWNER, signed before a notary and returned to The Secretary of the Board of Zoning Appeals.

I/We Michael O'Brien
(OWNER)

Address: 65 Sparks Street, Unit 4, Cambridge, MA 02138

State that I/We own the property located at 65 Sparks Street, Unit 4, Cambridge, MA 02138, which is the subject of this zoning application.

The record title of this property is in the name of _____
Feanil Patel, Klersten C. Kerby-Patel, Ivy Lee, Blake A. Sessions, Michael O'Brien, BriannaMcHorse and David Laibstain

*Pursuant to a deed of duly recorded in the date 8/3/2021, Middlesex South County Registry of Deeds at Book 78390, Page 525; or Middlesex Registry District of Land Court, Certificate No. _____
Book _____ Page _____.

[Signature]
SIGNATURE BY LAND OWNER OR AUTHORIZED TRUSTEE, OFFICER OR AGENT*

*Written evidence of Agent's standing to represent petitioner may be requested.

Commonwealth of Massachusetts, County of Middlesex

The above-name Michael O'Brien personally appeared before me, this 7th of Nov, 2022, and made oath that the above statement is true.

[Signature] Notary

My commission expires 2/5/2027 (Notary Seal).

- If ownership is not shown in recorded deed, e.g. if by court order, recent deed, or inheritance, please include documentation.

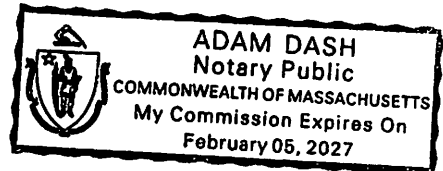

BZA APPLICATION FORM - OWNERSHIP INFORMATION

To be completed by OWNER, signed before a notary and returned to The Secretary of the Board of Zoning Appeals.

I/We Brianna McHorse
(OWNER)

Address: 65 Sparks Street, Unit 4, Cambridge, MA 02138

State that I/We own the property located at 65 Sparks Street, Unit 4, Cambridge, MA 02138, which is the subject of this zoning application.

The record title of this property is in the name of _____
Feanil Patel, Kiersten C. Kerby-Patel, Ivy Lee, Blake A. Sessions, Michael O'Brien, BriannaMcHorse and David Laibstain

*Pursuant to a deed of duly recorded in the date 8/3/2021, Middlesex South County Registry of Deeds at Book 78390, Page 525; or Middlesex Registry District of Land Court, Certificate No. _____
Book _____ Page _____.



**SIGNATURE BY LAND OWNER OR
AUTHORIZED TRUSTEE, OFFICER OR AGENT***

***Written evidence of Agent's standing to represent petitioner may be requested.**

Commonwealth of Massachusetts, County of Middlesex

The above-name Brianna McHorse personally appeared before me, this 21st of Nov., 2022, and made oath that the above statement is true.



Notary

My commission expires 2/5/2027 (Notary Seal).

- If ownership is not shown in recorded deed, e.g. if by court order, recent deed, or inheritance, please include documentation.

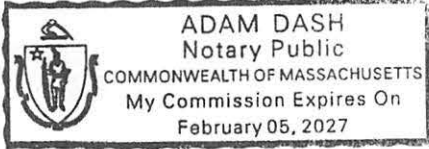

BZA APPLICATION FORM - OWNERSHIP INFORMATION

To be completed by OWNER, signed before a notary and returned to The Secretary of the Board of Zoning Appeals.

I/We David Laibstain
(OWNER)

Address: 65 Sparks Street, Unit 4, Cambridge, MA 02138

State that I/We own the property located at 65 Sparks Street, Unit 4, Cambridge, MA 02138, which is the subject of this zoning application.

The record title of this property is in the name of _____
Feanil Patel, Kiersten C. Kerby-Patel, Ivy Lee, Blake A. Sessions, Michael O'Brien, BriannaMcHorse and David Laibstain

*Pursuant to a deed of duly recorded in the date 8/3/2021, Middlesex South County Registry of Deeds at Book 78390, Page 525; or Middlesex Registry District of Land Court, Certificate No. _____
Book _____ Page _____.

SIGNATURE BY LAND OWNER OR AUTHORIZED TRUSTEE, OFFICER OR AGENT*

*Written evidence of Agent's standing to represent petitioner may be requested.

Commonwealth of Massachusetts, County of Middlesex

The above-name David B. Laibstain personally appeared before me, this 21st of Nov, 2022 and made oath that the above statement is true.

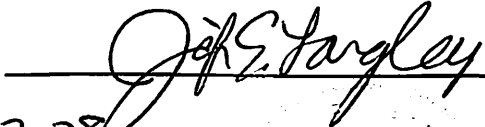
 Notary

My commission expires 5/26/2028 (Notary Seal).

- If ownership is not shown in recorded deed, e.g. if by court order, recent deed, or inheritance, please include documentation.

THE UNIVERSITY OF CHICAGO

PHYSICS DEPARTMENT

1155 EAST 58TH STREET

CHICAGO, ILLINOIS 60637

TEL: 773-936-3700

FAX: 773-936-3701

WWW.PHYSICS.UCHICAGO.EDU

ADMISSIONS OFFICE

1155 EAST 58TH STREET

CHICAGO, ILLINOIS 60637

TEL: 773-936-3700

FAX: 773-936-3701

WWW.PHYSICS.UCHICAGO.EDU

ADMISSIONS OFFICE

1155 EAST 58TH STREET

CHICAGO, ILLINOIS 60637

TEL: 773-936-3700

FAX: 773-936-3701

WWW.PHYSICS.UCHICAGO.EDU

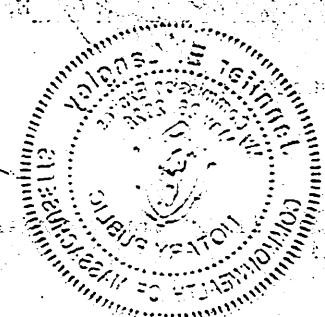

BZA Application Form

SUPPORTING STATEMENT FOR A VARIANCE

EACH OF THE FOLLOWING REQUIREMENTS FOR A VARIANCE MUST BE ESTABLISHED AND SET FORTH IN COMPLETE DETAIL BY THE APPLICANT IN ACCORDANCE WITH MGL 40A, SECTION 10.

A) A literal enforcement of the provisions of this Ordinance would involve a substantial hardship, financial or otherwise, to the petitioner or appellant for the following reasons:

The use and number of units will not change. The dormer is needed to create quiet space for home office use, as the residents have a small child and have had to work from home in the child's play space since the pandemic began. The premises does not currently have any home office space for conducting research and attending remote meetings. Due to the pre-existing, nonconforming nature of the premises, Applicants cannot create this needed space without relief.

B) The hardship is owing to the following circumstances relating to the soil conditions, shape or topography of such land or structures and especially affecting such land or structures but not affecting generally the zoning district in which it is located for the following reasons:

The hardship is due to the existing conditions, including the narrowness of the lot and building, being a townhouse, such that the pre-existing nonconforming nature of the premises requires relief.

C) DESIRABLE RELIEF MAY BE GRANTED WITHOUT EITHER:

1) Desirable relief may be granted without substantial detriment to the public good for the following reasons:

Adding a dormer without increasing the number of units, while providing more room for the residents to work from home such that a growing family can remain in Cambridge, is a benefit to the neighborhood and the City. Other townhouses in the same row have dormers currently, such that this dormer will be in character with the rest of block. The requested relief is minimal.

2) Desirable relief may be granted without nullifying or substantially derogating from the intent or purpose of this Ordinance for the following reasons:

The proposed work enhances the livability of the Premises and continues to fit the characteristics and needs of the neighborhood and community. The minimal 0.03 increase in FAR (being 115 sf) as a result of the dormer will result in the building being more usable for families staying in Cambridge while continuing the addition of dormers on other townhouses in the row. There will not be any noticeable impact on the overall look, feel, or traffic pattern in the neighborhood, and there will be no additional units created.

***If you have any questions as to whether you can establish all of the applicable legal requirements, you should consult with an attorney.**

BZA Application Form

DIMENSIONAL INFORMATION

Applicant: Feanil Patel, Kiersten C. Kerby-Patel, Ivy Lee, Blake A. Sessions, Michael O'Brien, Brianna McHorse and David Laibstain
Location: 65 Sparks St., Unit 4, Cambridge, MA
Phone: 617-625-7373

Present Use/Occupancy: Residential
Zone: Residence A-2 Zone
Requested Use/Occupancy: Residential

		<u>Existing Conditions</u>	<u>Requested Conditions</u>	<u>Ordinance Requirements</u>	
TOTAL GROSS FLOOR AREA:		5,335	5,450	3,000	(max.)
LOT AREA:		3,125	3,125	8,000	(min.)
RATIO OF GROSS FLOOR AREA TO LOT AREA: ²		1.71	1.74	0.5	
LOT AREA OF EACH DWELLING UNIT		781	781	6,000	
SIZE OF LOT:	WIDTH	25	25	80	
	DEPTH	125	125	100	
SETBACKS IN FEET:	FRONT	24	24	25	
	REAR	43.2	43.2	25	
	LEFT SIDE	0	0	15 (sum to 35)	
	RIGHT SIDE	0	0	15 (sum to 35)	
SIZE OF BUILDING:	HEIGHT	53.76	53.76	35	
	WIDTH	57.8	57.8	N/A	
	LENGTH	25	25	N/A	
RATIO OF USABLE OPEN SPACE TO LOT AREA:		53.8%	53.8%	50%	
NO. OF DWELLING UNITS:		1	1	1	
NO. OF PARKING SPACES:		0	0	1	
NO. OF LOADING AREAS:		N/A	N/A	N/A	
DISTANCE TO NEAREST BLDG. ON SAME LOT		N/A	N/A	N/A	

Describe where applicable, other occupancies on the same lot, the size of adjacent buildings on same lot, and type of construction proposed, e.g; wood frame, concrete, brick, steel, etc.:

None

1. SEE CAMBRIDGE ZONING ORDINANCE ARTICLE 5.000, SECTION 5.30 (DISTRICT OF DIMENSIONAL REGULATIONS).
2. TOTAL GROSS FLOOR AREA (INCLUDING BASEMENT 7'-0" IN HEIGHT AND ATTIC AREAS GREATER THAN 5') DIVIDED BY LOT AREA.
3. OPEN SPACE SHALL NOT INCLUDE PARKING AREAS, WALKWAYS OR DRIVEWAYS AND SHALL HAVE A MINIMUM DIMENSION OF 15'.

Naomi Yang
Damon Krukowski
61 Sparks Street, Apt 1
Cambridge, MA 02138
tel. 617-492-1934

Jan 27, 2023

To the Cambridge Board of Zoning Appeal:

We have lived in 61 Sparks Street since 1995 and we would like to express our full support for the proposed addition of dormers and terrace at 65 Sparks Unit 4 (Case no. BZA-206407). It is in scale with the original building, sensitively done, and a welcome addition to the streetscape.

Sincerely,

Naomi Yang
Damon Krukowski

Pacheco, Maria

From: Rob Tagiuri <rob.tagiuri@verizon.net>
Sent: Monday, January 30, 2023 1:59 PM
To: Pacheco, Maria
Subject: Re:BZA Hearing 206407

Dear Ms. Pacheco,

I am the building manager of 67 Sparks Street Cambridge. It abuts 65 Sparks Street. The owners of that building have applied for a zoning variance, as there is a sign to that effect in front of the building. I also received the notice of the hearing, BZA 206407. It states that a variance is being requested for a single dormer. However I have met with the petitioners and their plans show two dormers and a deck.

I would request that the hearing be postponed and for another notice to be sent to abutters once the confusion between the petitioners and the Board of Zoning Appeal is resolved.

Please acknowledge receipt of this email.

Thank you for your attention to this matter,

Rob Tagiuri

617-821-8490

ADAM DASH & ASSOCIATES
ATTORNEYS AT LAW

48 GROVE STREET, SUITE 304
DAVIS SQUARE
SOMERVILLE, MA 02144

TELEPHONE (617) 625-7373
FAX (617) 625-9452
www.adamdashlaw.com

ADAM DASH
PAUL METSCHER
MARK SHEEHAN

VIA EMAIL AND VIA FIRST CLASS MAIL, POSTAGE PRE-PAID

January 31, 2023

Board of Zoning Appeals
City of Cambridge
831 Massachusetts Avenue
Cambridge, MA 02139

ATTN: Maria Pacheco

RE: Application for Variance
Applicants: Feanil Patel, Kiersten C. Kerby-Patel, Ivy Lee, Blake A. Sessions,
Michael O'Brien, Brianna McHorse and David Laibstain
Location Address: 65 Sparks Street, Unit 4, Cambridge, MA
Case Number: 206407

Dear Ms. Pacheco:

On behalf of the Applicants in this matter, I hereby request a continuance of the above-referenced application, being BZA 206407 for 65 Sparks Street, Unit 4, from the February 9, 2023 BZA meeting until the February 23, 2023 meeting.

Should you have any questions or need any additional documentation, please contact this office. I can also be reached via e-mail at dash@adamdashlaw.com.

Thank you for your prompt attention to this matter.

Very truly yours,



Adam Dash



City of Cambridge

MASSACHUSETTS

BOARD OF ZONING APPEAL

831 Mass Avenue, Cambridge, MA.
(617) 349-6100

2023 FEB -1 PM 12: 22

OFFICE OF THE CITY CLERK
CAMBRIDGE, MASSACHUSETTS

Board of Zoning Appeal Waiver Form

The Board of Zoning Appeal
831 Mass Avenue
Cambridge, MA 02139

RE: Case # BZA-206407

Address: 65 Sparks St #4

Owner, Petitioner, or Representative: Adam Dash, Esq.
(Print Name)

hereby waives the required time limits for holding a public hearing as required by Section 9 or Section 15 of the Zoning Act of the Commonwealth of Massachusetts, Massachusetts General Laws, Chapter 40A. The Owner, Petitioner, or Representative further hereby waives the Petitioner's and/or Owner's right to a Decision by the Board of Zoning Appeal on the above referenced case within the time period as required by Section 9 or Section 15 of the Zoning Act of the Commonwealth of Massachusetts, Massachusetts General Laws, Chapter 40A, and/or Section 6409 of the federal Middle Class Tax Relief and Job Creation Act of 2012, codified as 47 U.S.C. §1455(a), or any other relevant state or federal regulation or law.

Date: 1/31/23

[Signature]
Signature



City of Cambridge

MASSACHUSETTS

BOARD OF ZONING APPEAL

831 Mass Avenue, Cambridge, MA.
(617) 349-6100

BZA

POSTING NOTICE – PICK UP SHEET

The undersigned picked up the notice board for the Board of Zoning Appeals Hearing.

Name: Fanil Patel Date: 1/19/2023
(Print)

Address: 65 Sparks St. Unit 4.

Case No. BZA-206407

Hearing Date: 2/9/23

Thank you,
Bza Members

Pacheco, Maria

From: Adam Dash <dash@adamdashlaw.com>
Sent: Monday, March 20, 2023 1:37 PM
To: Pacheco, Maria
Cc: Natola, Stephen; Ratay, Olivia
Subject: 65 Sparks Street continuances

Maria,

My clients would like to continue the 65 Sparks Street cases which are on for this Thursday, being 206407 and 209310, until a BZA hearing date in May (which I understand is the soonest date we could have).

You may recall that the last continuance was requested by an abutter, and not by the Applicants, so I would hope we would be granted this extension on Thursday night.

I am talking with the abutter's attorney about possible resolution of this matter, now that he is back in the country, so more time would help.

Which date in May do you think we would get?

Thanks.

Adam Dash, Esq.
Adam Dash & Associates
48 Grove Street, Suite 304
Davis Square
Somerville, MA 02144
(617) 625-7373 phone
(617) 625-9452 fax

This communication is intended only for the use of the individual or entity named as the addressee. It may contain information that is privileged and/or confidential. If you are not the intended recipient, any dissemination, copying or disclosure of this communication is strictly prohibited. If you have received this communication in error, please notify us immediately at (617) 625-7373 or via return Internet e-mail and delete this communication without making any copies.

1 * * * * *

2 (8:11 p.m.)

3 Sitting Members: Brendan Sullivan, Wendy Leiserson, Jim
4 Monteverde, Slater W. Anderson, and Matina
5 Williams

6 BRENDAN SULLIVAN: The Board will now hear Case
7 No. 206407 -- 65 Sparks Street, Unit 4. Is the petitioner
8 on the line?

9 ADAM DASH: Yes, Mr. Chair.

10 BRENDAN SULLIVAN: Mr. Dash?

11 ADAM DASH: Yes.

12 BRENDAN SULLIVAN: How are you?

13 ADAM DASH: Good. I'm doing very well, Mr. Chair.

14 And yourself?

15 BRENDAN SULLIVAN: Great.

16 ADAM DASH: It's Adam Dash, from Adam Dash &
17 Associates, 48 Grove Street, Suite 304, Somerville,
18 Massachusetts, 02144 for the applicants.

19 Mr. Chair, the applicants are seeking a
20 continuance because there was a notice issue that was
21 raised. And we have fixed it, but we do not want to go
22 forward tonight, and we would like to come back.

1 BRENDAN SULLIVAN: Okay. Do we have a particular
2 date?

3 ADAM DASH: I would note, Mr. Chair, that there is
4 a companion case to this that is on the Agenda for February
5 23. I know you've stated earlier you're kind of packed
6 that night, but it would be best to hear that other case and
7 then -- because that would possibly render this case moot,
8 should the Board approve that other case. So doing them all
9 in the same night would be sort of an economy of scale, if
10 that's -- for what it's worth it.

11 BRENDAN SULLIVAN: We do not have -- no, that
12 other case was -- was granted? Yeah, we don't have any
13 other one for Sparks Street. No. There's only -- no, there
14 is no other case for Sparks Street on our Agenda.

15 JIM MONTEVERDE: There is.

16 BRENDAN SULLIVAN: So -- so, no, so the other one
17 was --

18 JIM MONTEVERDE: Sorry, Mr. Chair?

19 BRENDAN SULLIVAN: Yes?

20 JIM MONTEVERDE: It's -- I have the Agenda for the
21 twenty-third and it's on at 6:30.

22 BRENDAN SULLIVAN: Oh, I'm sorry.

1 JIM MONTEVERDE: 65 Sparks, Unit 4.

2 ADAM DASH: Thank you.

3 JIM MONTEVERDE: I was scratching my head, because
4 it looks like the same thing we're doing, but it's a
5 variance then for the -- yeah, it reads the same.

6 ADAM DASH: It's a correction, Mr. Chair. It's a
7 correction of the notice that went out as to the relief
8 being sought, which I take responsibility for not being as
9 clear in the application originally as I probably could have
10 been.

11 So we're trying to make sure that everything is
12 tidied up, so we don't have any technical issues. So if we
13 do the new case first on the twenty-third, if the Board were
14 to approve it, then this case we would need to -- it would
15 be to withdraw it as being moot at that time.

16 But we don't know what's going to happen on the
17 twenty-third with the other case, so --

18 BRENDAN SULLIVAN: Yeah. Yeah, unfortunately the
19 -- I'm sorry, what -- Jim, what time did you say? I don't
20 have that.

21 JIM MONTEVERDE: It's first up at the bat, 6:30.

22 BRENDAN SULLIVAN: 6:30. Okay. We have defined

1 times for all the other cases. The other option would be to
2 kick this over to March 23, and should you get a favorable
3 on the twenty-third for the other case, then this one here
4 can just go away on March 23.

5 ADAM DASH: That would work as well?

6 BRENDAN SULLIVAN: Okay. So why don't we schedule
7 this for March 23, 2023 at 6:00 p.m.? And that's 65 Sparks.

8 Ok. On the condition that the petitioner change
9 the posting sign to reflect the new date of March 23, 2023
10 and the new time of 6:00 p.m., and that that posting sign be
11 maintained at least 14 days prior to the March 23 hearing.

12
13 Any new submittals not currently should be
14 submitted by 5:00 p.m. on the Monday prior to the March 23,
15 2023 hearing. I would ask if you haven't already signed a
16 waiver?

17 ADAM DASH: We have, Mr. Chair.

18 BRENDAN SULLIVAN: We have. You have. All right.
19 So that is in the file. And I think that should cover it.
20 So on the motion, then, to continue this matter to March 23,
21 2023, Jim Monteverde?

22 JIM MONTEVERDE: In favor.

1 BRENDAN SULLIVAN: Matina Williams?

2 MATINA WILLIAMS: In favor.

3 BRENDAN SULLIVAN: Slater Anderson?

4 SLATER ANDERSON: In favor.

5 WENDY LEISERSON: In favor.

6 BRENDAN SULLIVAN: In favor.

7 [All vote YES]

8 BRENDAN SULLIVAN: On the five affirmative votes,
9 this matter is continued until March 23, 2023 at 6:00 p.m.

10 Okay, thank you, Mr. Dash.

11 ADAM DASH: Thank you, Mr. Chair.

12 BRENDAN SULLIVAN: Yep. Is it 7:30 yet? Just
13 barely? Just barely. Okay.

14

15

16

17

18

19

20

21

22

Renovations to 65 Sparks Street Unit #3 Cambridge - MA

c.00

Owner:

KC Kerby and Feanil Patel | kkerby@gmail.com

65 Sparks Street | Cambridge | MA | 02138

November 2, 2022



Architect :



Bourque Design

Architectural Design from
Conception to Construction

Ron Bourque , Architect
AIA, NCARB, CS, LEED GA

rbourq@gmail.com
781-296-6654
Waltham, MA 02453



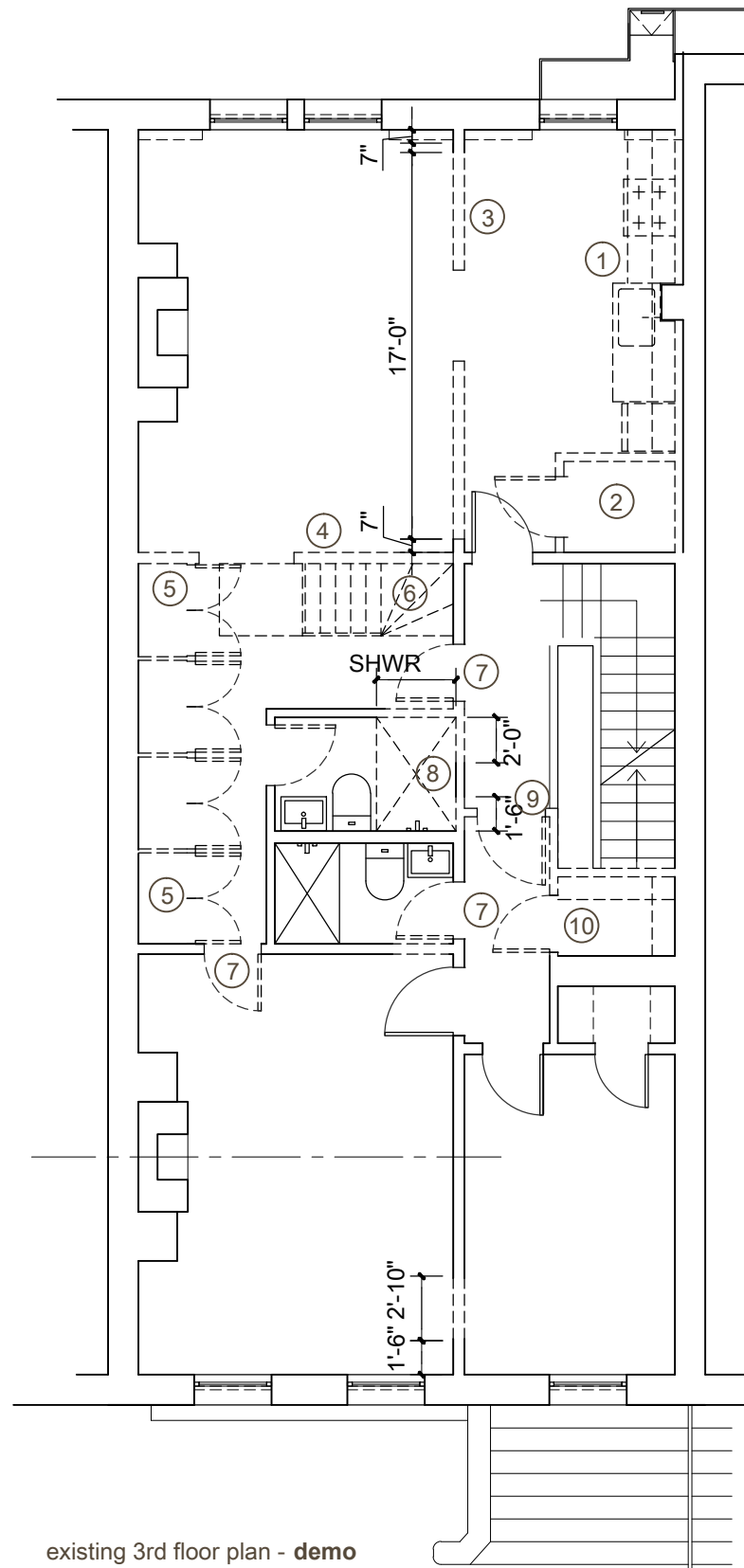

existing 3rd floor plan - demo

- demo notes:**
- 1 - remove all appliances, cabinets, counters, fixtures; make safe power, gas and plumbing
 - 2 - remove partitions, appliances, make safe power, plumbing, gas as required
 - 3 - remove existing wall floor to ceiling to plan dimension shown*
 - 4 - remove existing wall floor to ceiling, verify not structural
 - 5 - remove existing closets, doors, etc.
 - 6 - remove existing stairs when appropriate in construction sequence
 - 7 - remove existing door and wall as shown, shore as required
 - 8 - remove existing walls and shower as shown*
 - 9 - remove existing wall and door
 - 10 - remove existing closet walls, door and floor*
 - 11 - remove existing dormer*
 - 12 - remove existing roof back to existing beam and to plan width dimension shown, provide temporary roof protection*
 - 13 - exploratory removal to check roof framing in this location
 - 14 - remove existing walls, floor and flat skylight*
 - 15 - exploratory removal to check roof framing in this area
 - 16 - exploratory removal to check roof framing in this area
 - 17 - new opening for kitchen exhaust

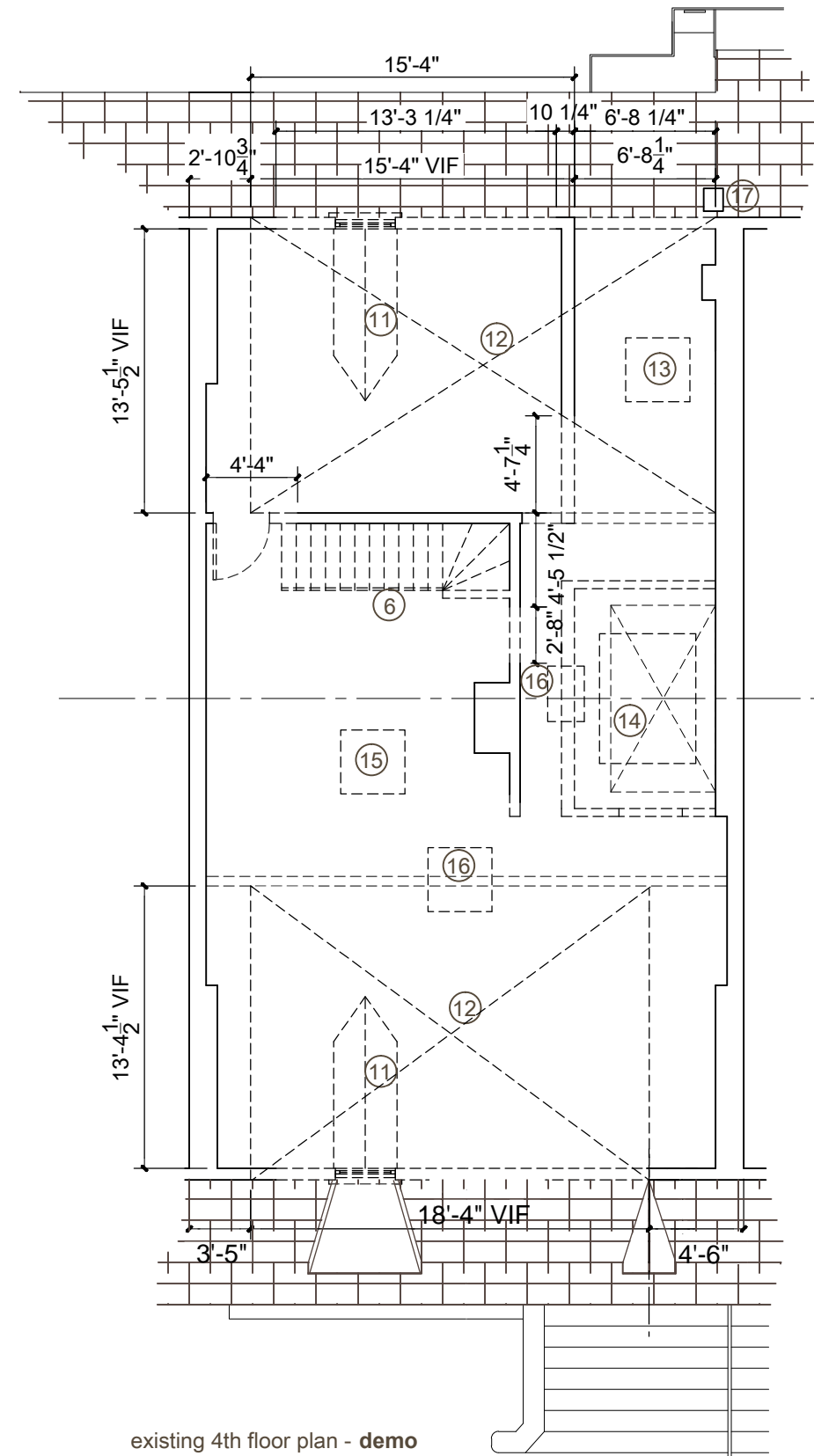

existing 4th floor plan - demo

* general note: new openings in walls to be confirmed as non-load bearing, if load-bearing, install appropriate shoring as required, headers, beams as required to support all necessary loads to grade. sizing, confirmation, fastening to be determined by a licensed professional.



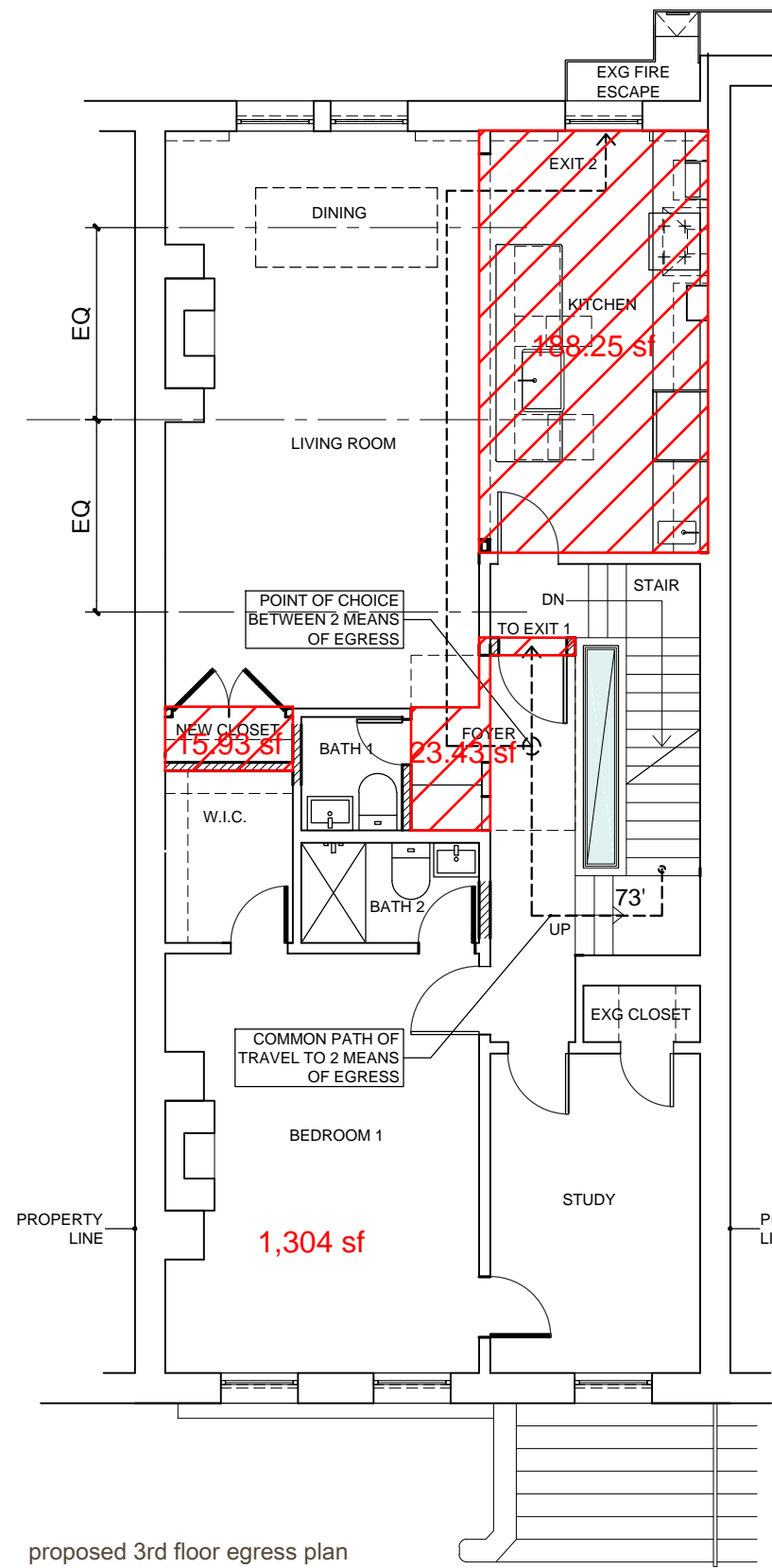

proposed 3rd floor egress plan

Code summary:

Building area - 4 floors (1,304 sf per flr) - 5,006 sf (not including 605 sf of Basement)

Work area - 2,324 sf on floors 3 and 4 total

Per EBC of MA, Section 504 Alteration - Level 2:
Work area is less than 50% of Building Area

New work complying with Chapter 7 and Chapter 8 of the EBC

Use Group: Remains Residential R-2, Multi-Family Residences

Chapter 7 Compliance

702.4 #3.1: New window sills are at 34" AFF

703.1: Level of existing fire protection separation of 4th floor is currently a non-rated, non-sealed false ceiling

705.1: General technically infeasible (no elevator space available). Building entrance is historic walk-up.

705.1.13: Extent of application level of accessibility does not change from the existing condition.

707.2: New roof will comply with current code.

708: New work will comply with the IECC.

Chapter 8 - Level 2 Alteration

801.2: Alteration Level 1 compliance with Chapter 7

805.6: Dead end corridors, Exception 2, 50' with FA system

803.2: Vertical openings, 803.2.1 existing vertical openings, exception 11.3: Enclosure note required with less than 4 units per floor (this is 1 unit per floor), sleeping rooms provided with direct access to window with sill less than 36" AFF (34"), and provided with FA system throughout.

803.2.3: Supplemental stairway enclosure requirements, 4th floor work area exceeds 50% of floor area, stairways that are part of a means of egress shall be enclosed with a smoke tight construction on the highest work area and all floors below.

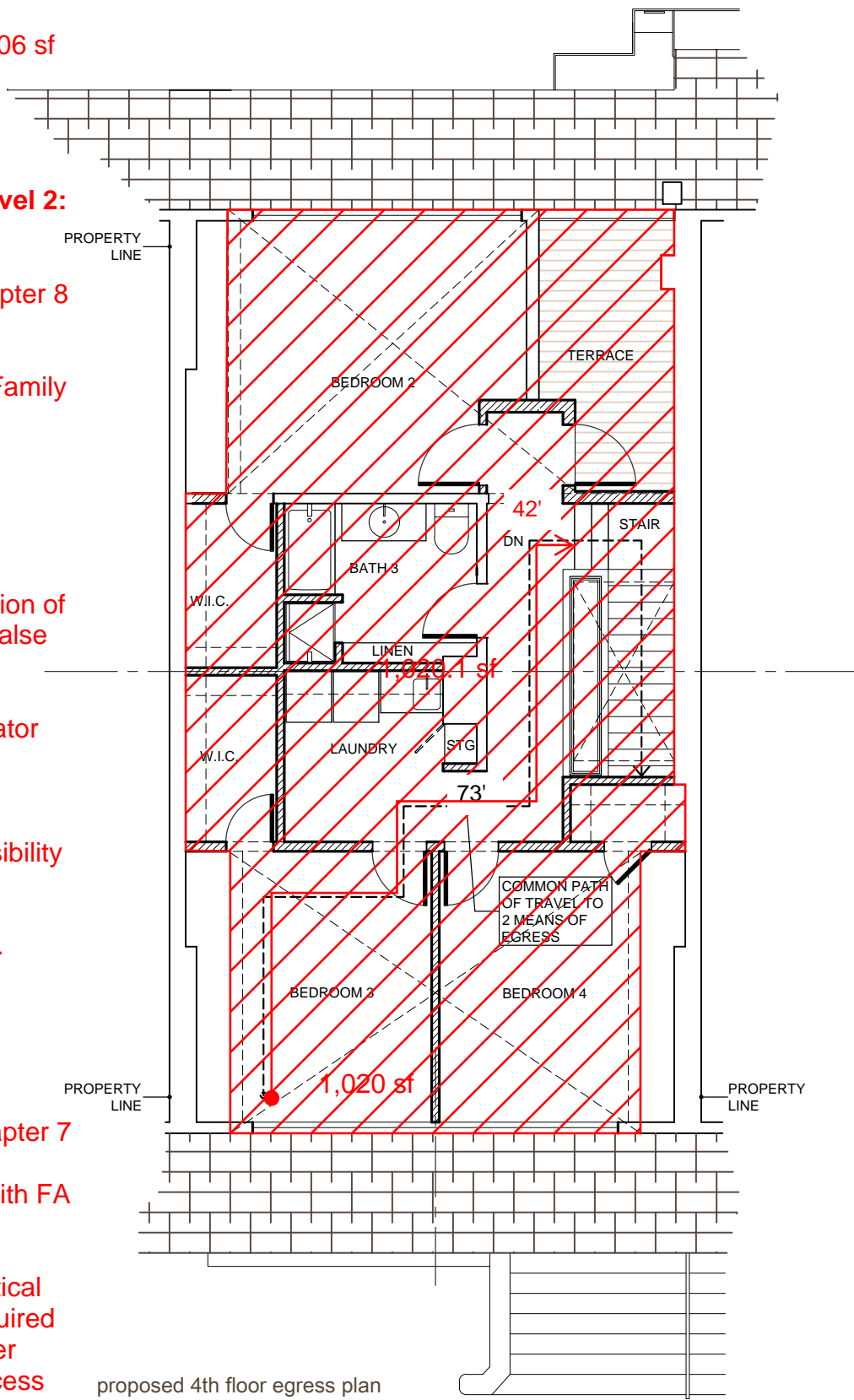

proposed 4th floor egress plan



KC Kerby and Feanil Patel | kkerby@gmail.com
65 Sparks Street | Cambridge | MA | 02138

November 2, 2022

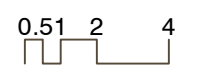

scope notes level 3:

- 1 - revise existing kitchen exhaust for more cfm, new unit
- 2 - new kitchen cabinets, counters, fixtures, appliances and lighting
- 3 - plumbing bar sink at end of counter
- 4 - new kitchen island containing sink base, dishwasher and pull-out trash unit
- 5 - install new underfloor beam in ceiling, lvls with high compression posts each end, follow load path to basement and install footing pads, all sized to applied loads*, finish with painted gwb and put 12" radius at each top corner of opening
- 6 - new all glass entry door with sweep seal, jamb/head seals, black hardware, confirm with owner
- 7 - *frame new opening w/ appropriate sized lvls and timberstrand posts, finish with painted gwb and painted trim (match existing)
- 8 - *new "prism" separator for units. either glass, clear plexiglass or frosted plexiglass. fasten to exiting structure (confirm loading and deflection) w/ cr laurence glass clips, channels, angles (black), seal edges with rigid silicone gaskets (CRL EZC 112-XCP5, sized per glass thickness, this number is for 12 cc). see a3.0.
- 9 - new wood cabinet and stone counter, 32" high. finish out opening at side with painted gwb and painted trim to match existing.
- 10 - construct new closet, new doors, steel pole (black), full-length shelf, painted gwb and trim to match existing
- 11 - new door, opening, painted trim and door, match height and style of existing
- 12 - start new stair at this level, treads/risers/railing to match existing
- 14 - Install detector, smoke (SD) or Carbon Monoxide (CO)

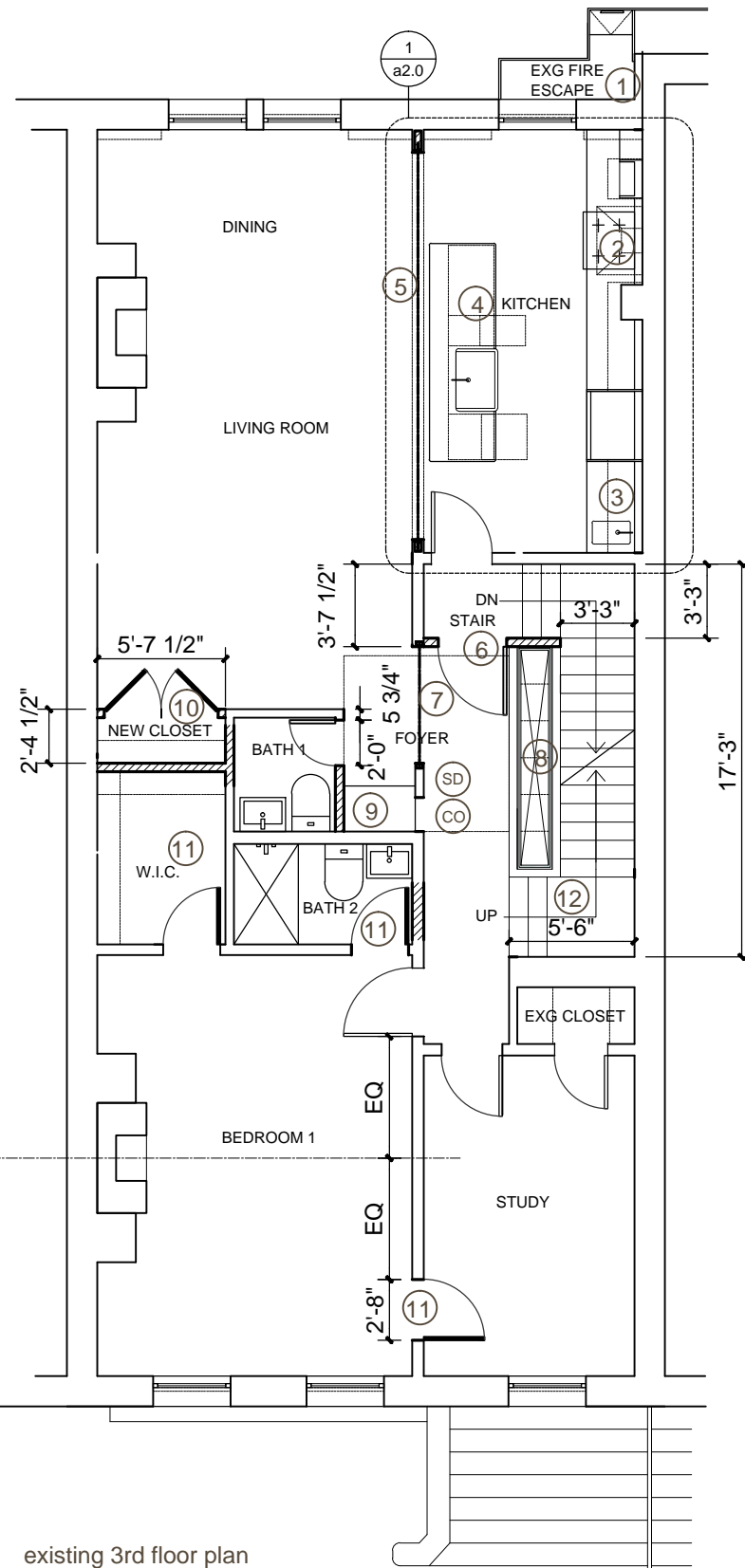

scope notes level 4:

- 21 - construct new vestibule, interior/exterior, fully insulated, ext and int painted wood doors, charred wood siding, fully insulated roof (align with dormer), painted gwb and wood floor.
- 22 - construct new dormer (pitch 1:12) with seam lock metal shingle (match existing) roofing on membrane underlay on 5/8" ext plywood deck on 2x rafters(*), to existing beam, fully insulated, copper gutter/leader, make watertigh with existing roof.
- 23 - new knee wall, fully insulated, with new wood insulated glazed window units (marvin magnum or equal), sill at 34.5" and head at 80" (verify with beam/header*), trim to match existing int/ext, 1x douglas fir charred wood siding (delta studios, austin, tx).
- 24 - patch/match existing roof as required, new 1 1/4" diameter black square stock aluminum guardrail at 42" aff.
- 25 - raft new deck on existing floor, 1x mahogany on 2x laid flat pt sleepers on 60 mil double membrane roofing on 5/8" ext plywood deck on existing joists, reinforce for any added loads (*).
- 26 - construct new closet, new doors, steel pole (black), full-length shelf, painted gwb and trim to match existing
- 27 - construct new bathroom, fixture selection by owner, wood vanity with stone counter, undermount sink, tile walls and floor, painted gwb ceiling, patined wood trim (match existing).
- 28 - new laundry, provide power/water/venting for washer/dryer (appliances by owner), new laundry sink in wood cabinet and stone top. tile floor, walls to 4', painted gwb remaining walls, ceiling and trim.
- 29 - construct new closet, new doors, steel pole (black), full-length shelf, painted gwb and trim to match existing
- 30 - construct new stair to match existing stair treads/risers/railing
- 31 - *new "prism" separator for units. either glass, clear plexiglass or frosted plexiglass. fasten to exiting structure (confirm loading and deflection) w/ cr laurence glass clips, channels, angles (black), seal edges with rigid silicone gaskets (CRL EZC 112-XCP5, sized per glass thickness, this number is for 12 cc). see a3.0.
- 32 - reinforce floor as required for prism dead loads, limit deflection to 3/8" total.
- 33 - patch/match existing roof as required to make watertight
- 34 - Install detector, smoke (SD) or Carbon Monoxide (CO)

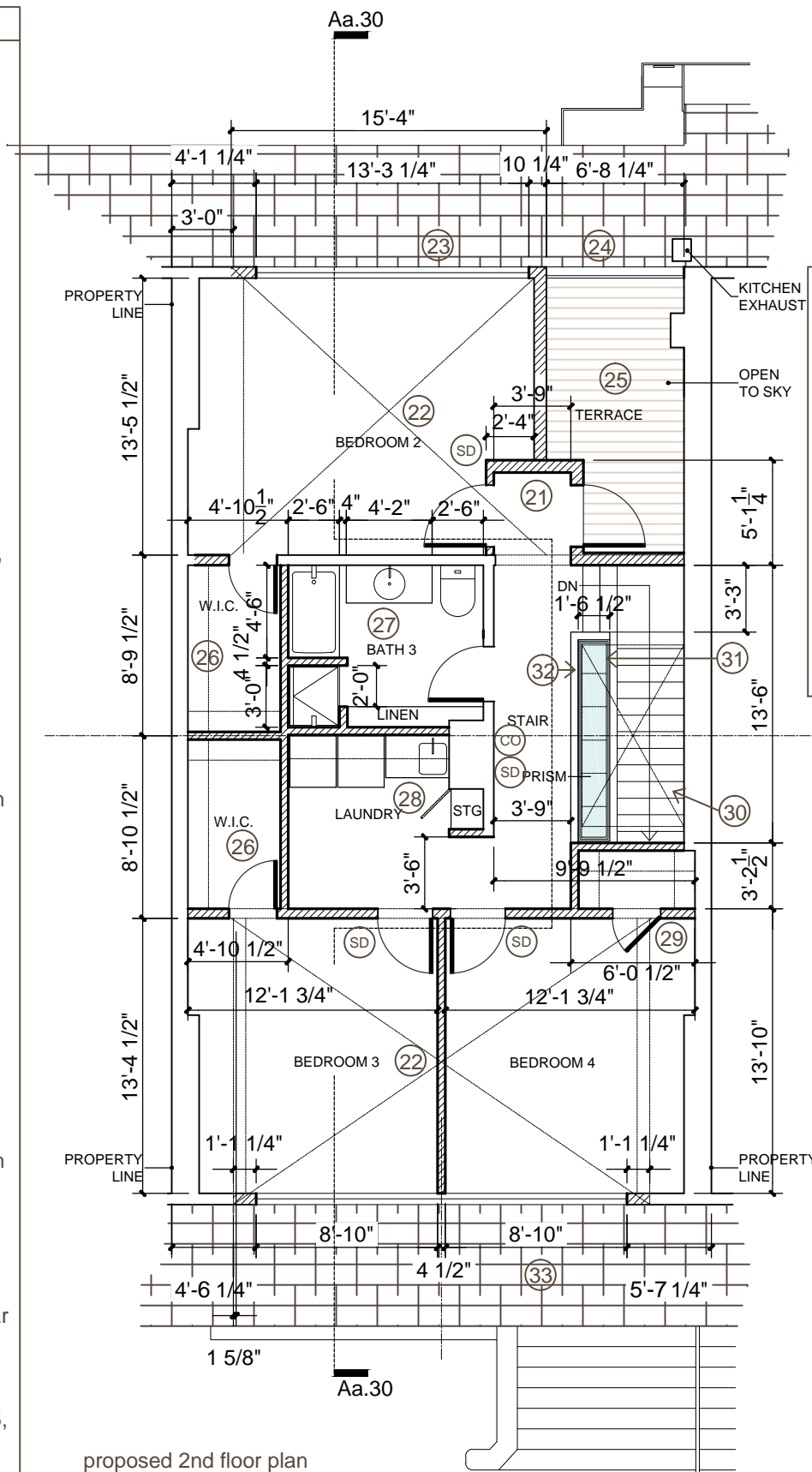

*** general note: new openings in walls to be confirmed as non-load bearing, if load-bearing, install appropriate shoring as required, headers, beams as required to support all necessary loads to grade. sizing, confirmation, fastening to be determined by a licensed engineer.**



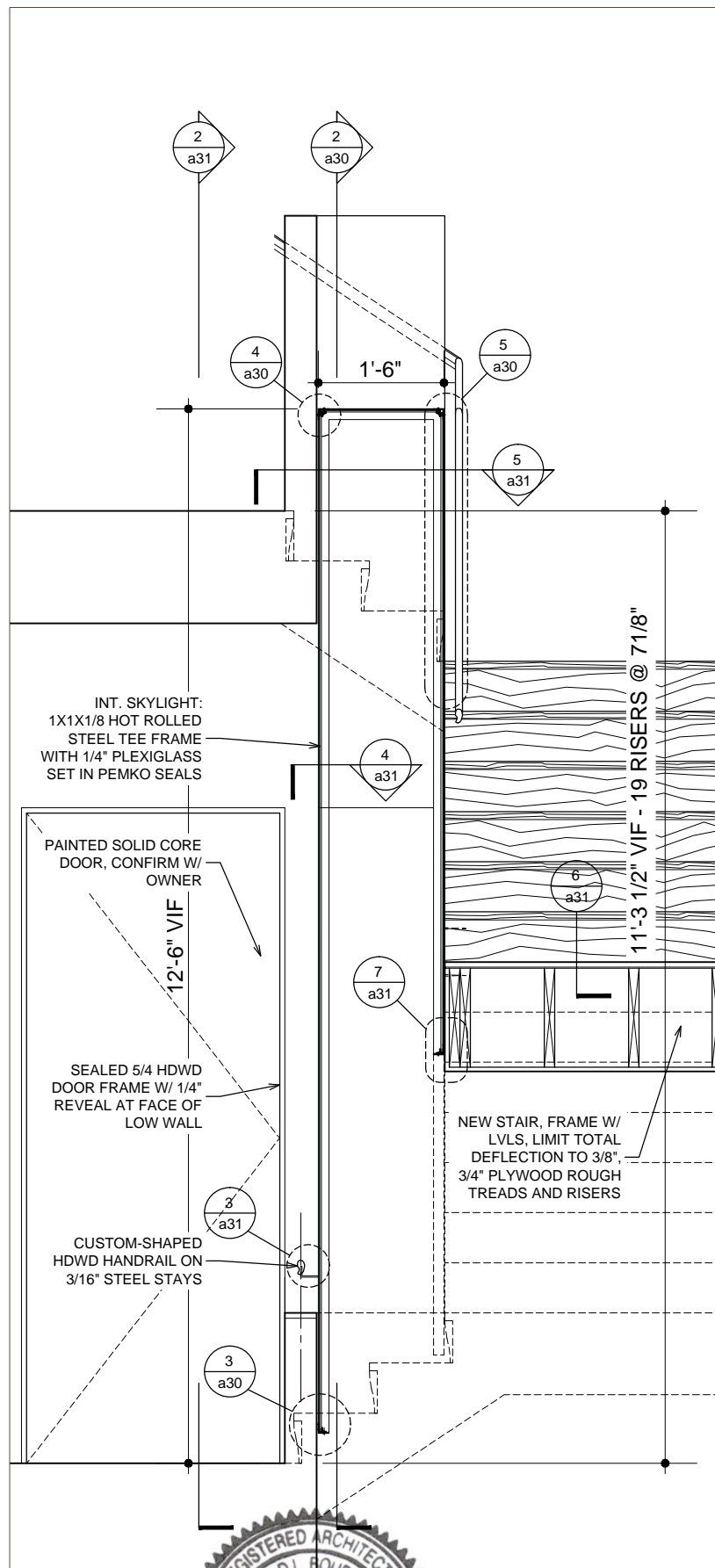

1 - new stair section with interior skylight - 1 1/2" = 1'-0"

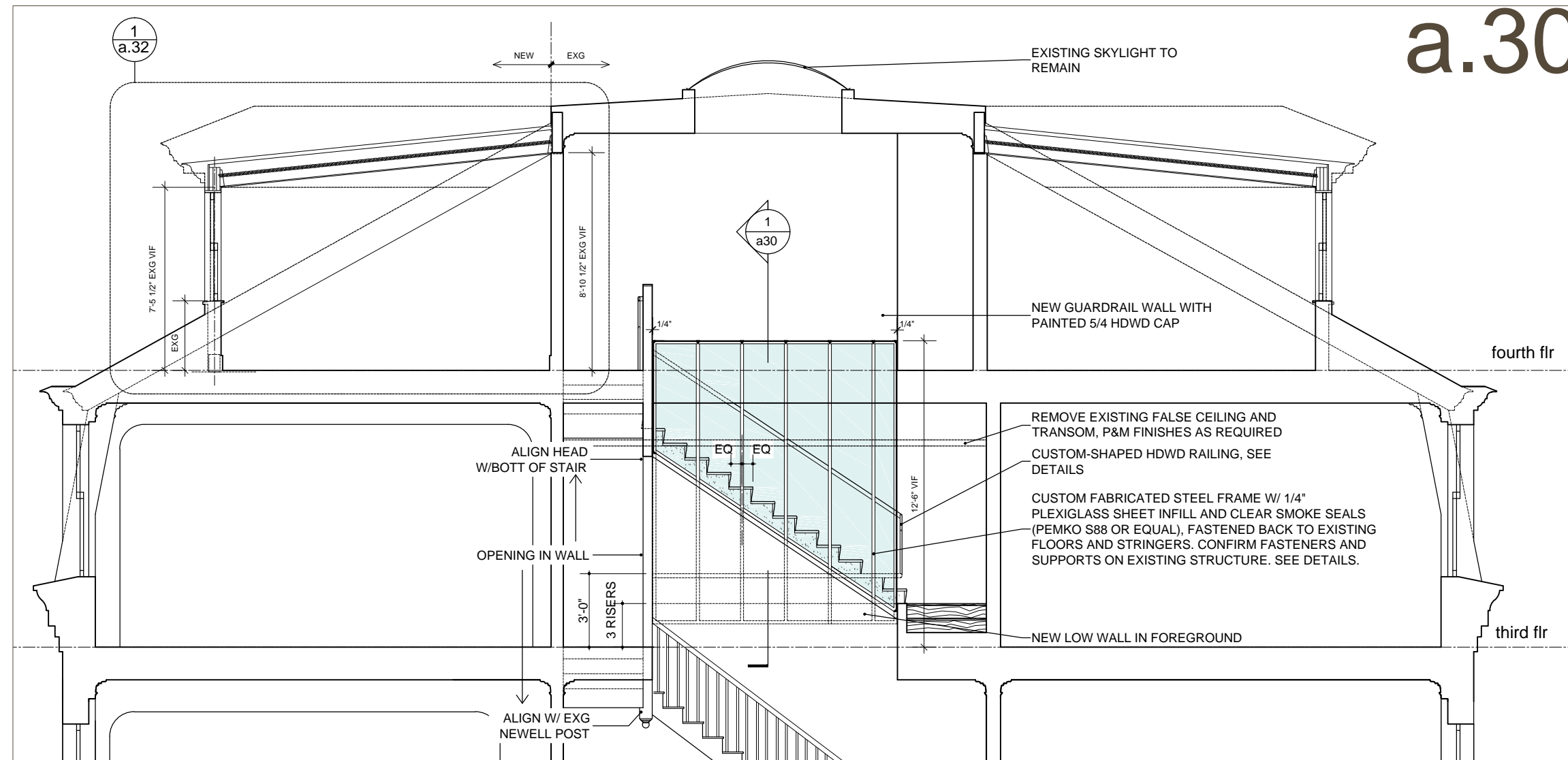

2 - new building section - 3/16" = 1'-0"

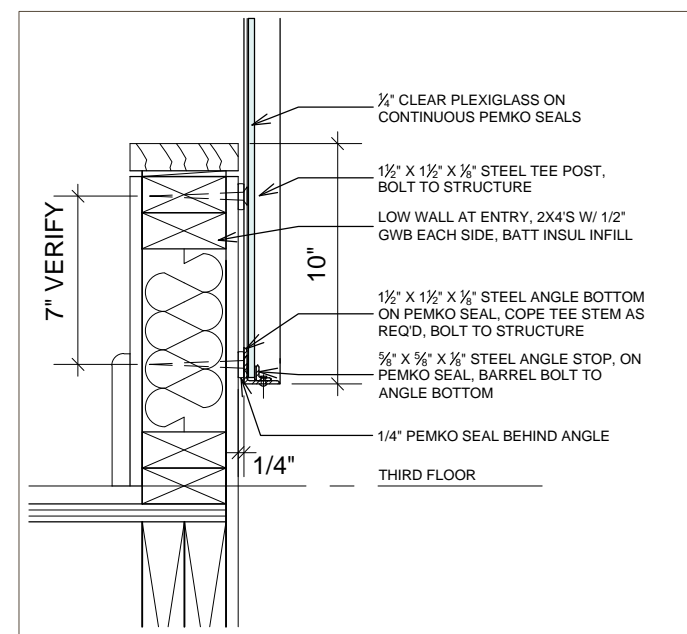

3 - detail at interior skylight support - 1 1/2" = 1'-0"

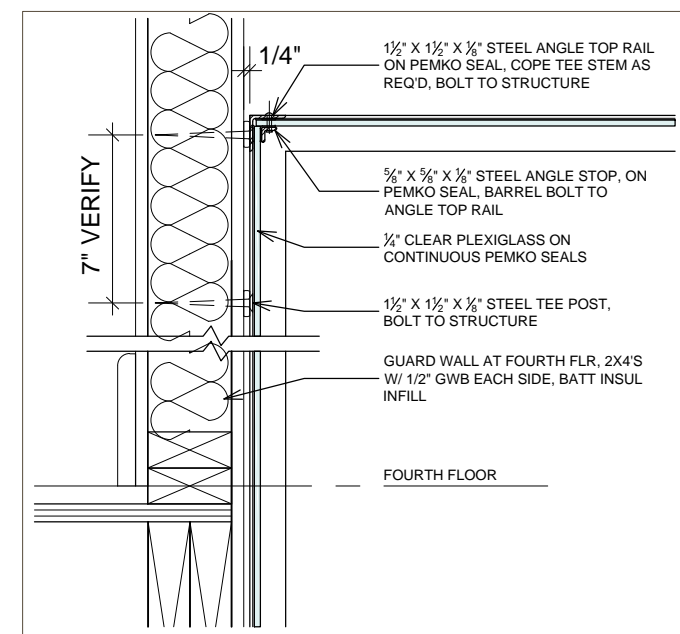

4 - detail at interior skylight support - 1 1/2" = 1'-0"

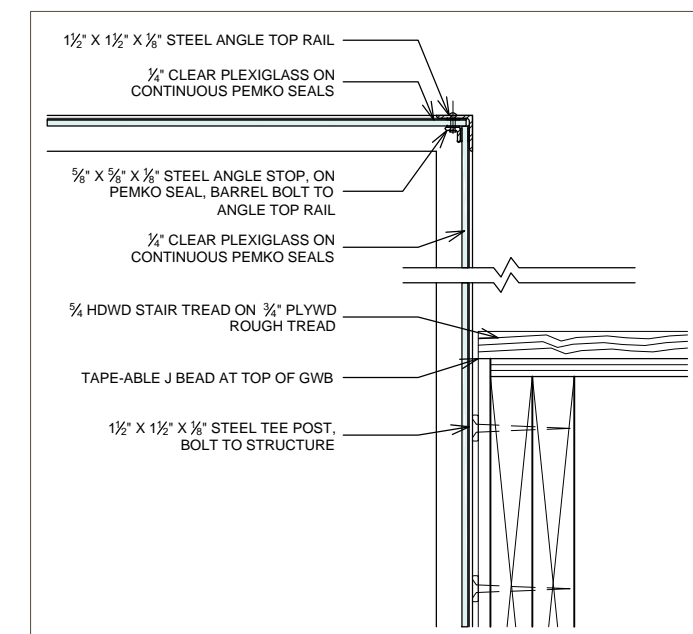

5 - detail at interior skylight support - 1 1/2" = 1'-0"

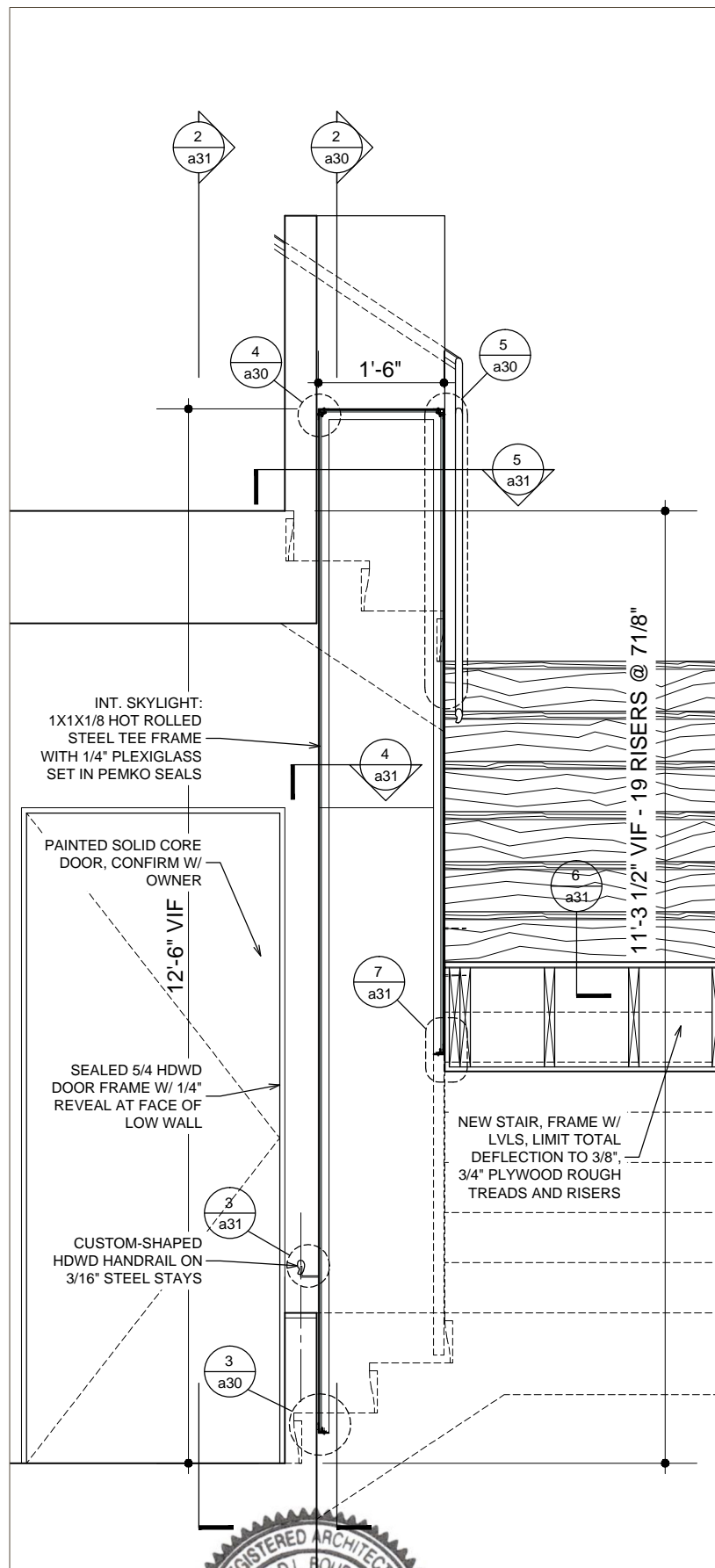

1 - new stair section with interior skylight - 1/2" = 1'-0"

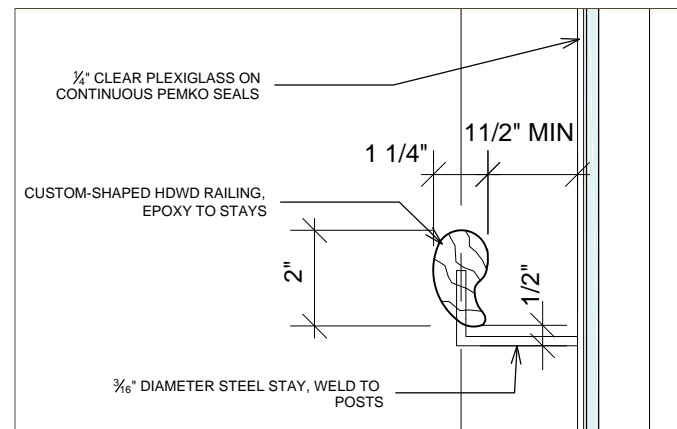

3 - detail at handrail support - 3" = 1'-0"

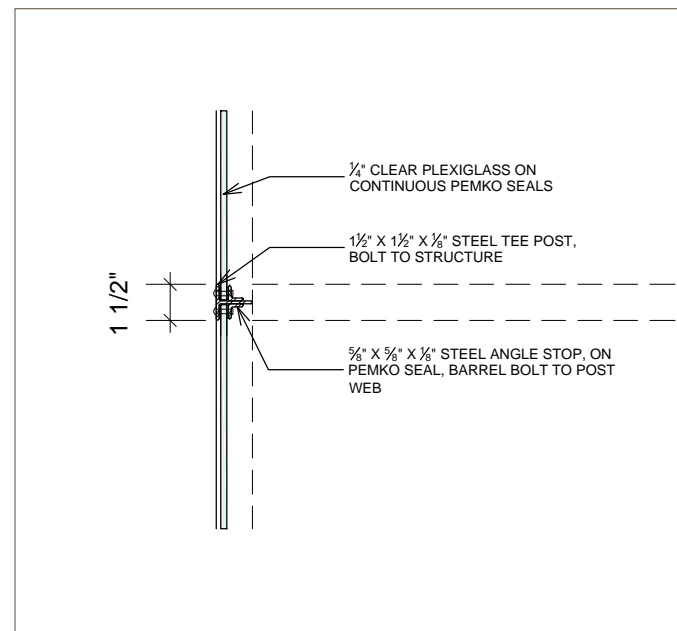

4 - detail at interior skylight post - 1 1/2" = 1'-0"

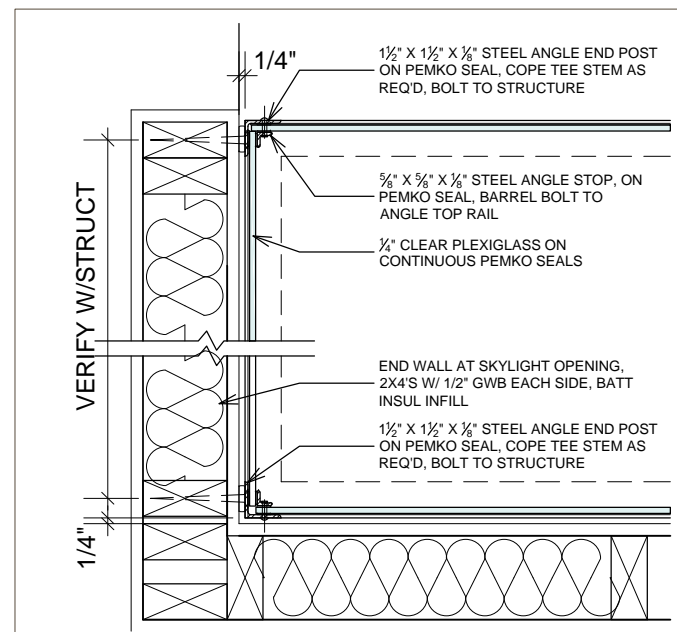

5 - detail at interior skylight end posts - 1 1/2" = 1'-0"

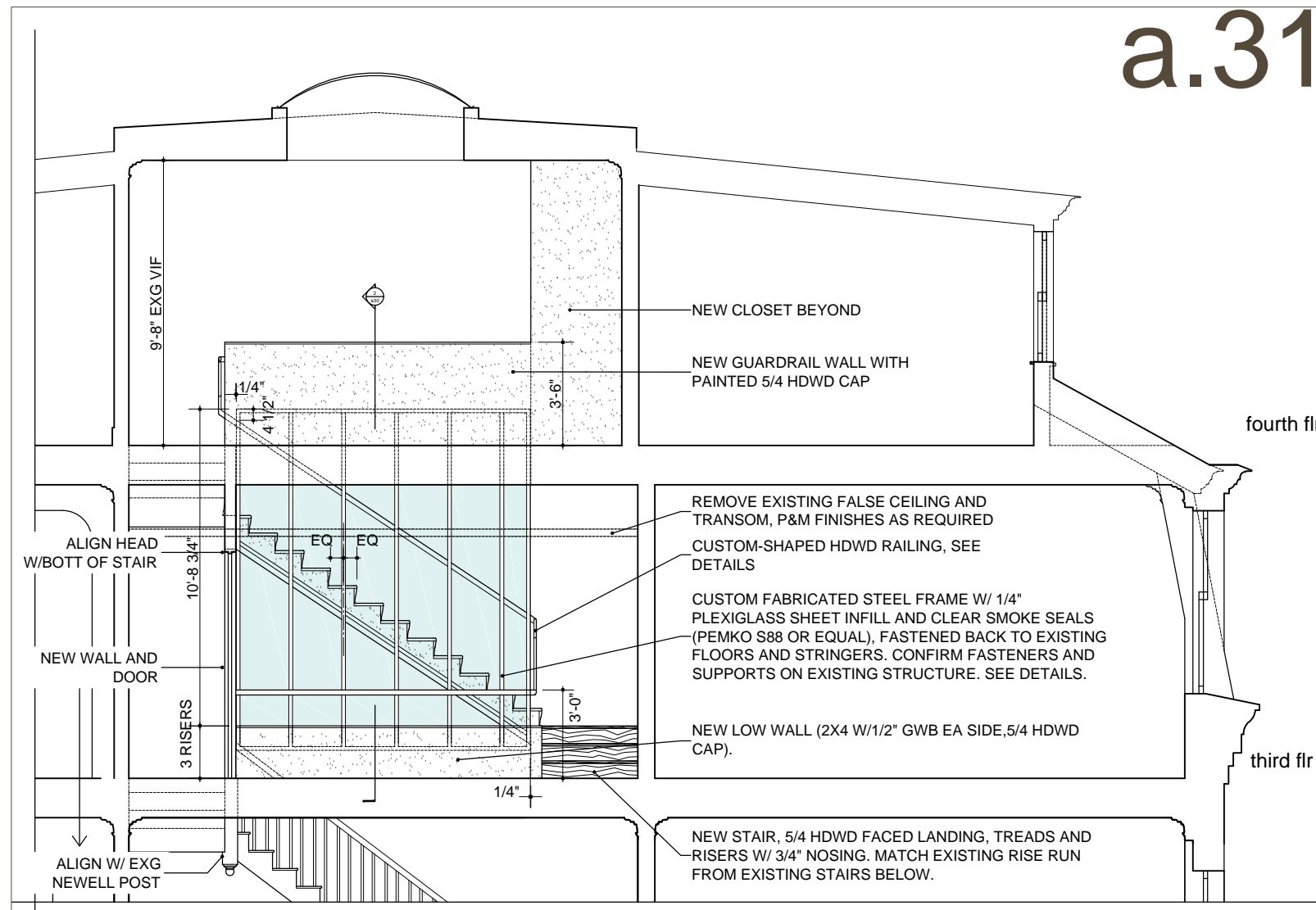

2 - new interior skylight elevation / section - 3/16" = 1'-0"

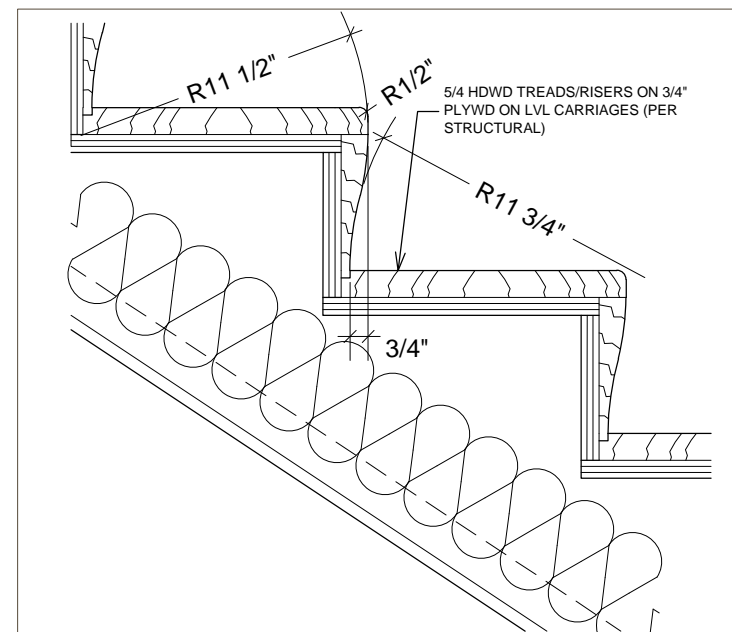

6 - detail at new stair treads/risers - 1 1/2" = 1'-0"

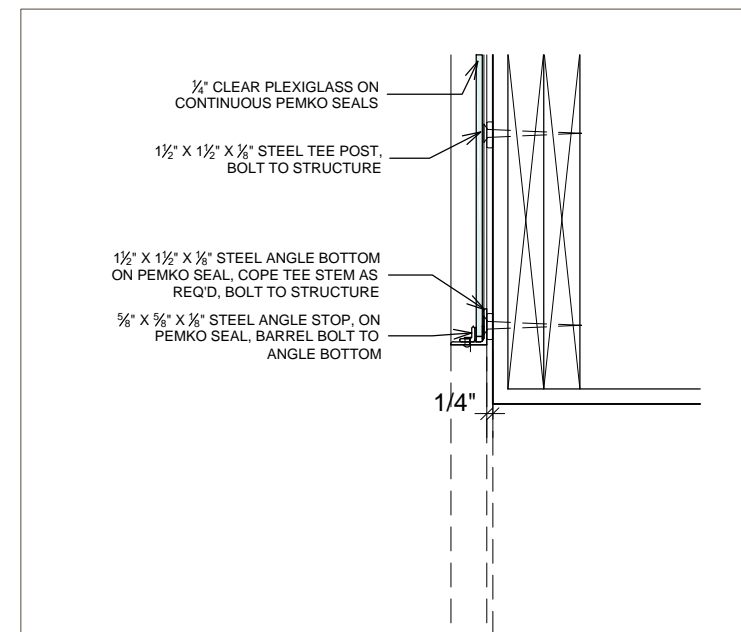

7 - detail at stair post base - 1 1/2" = 1'-0"

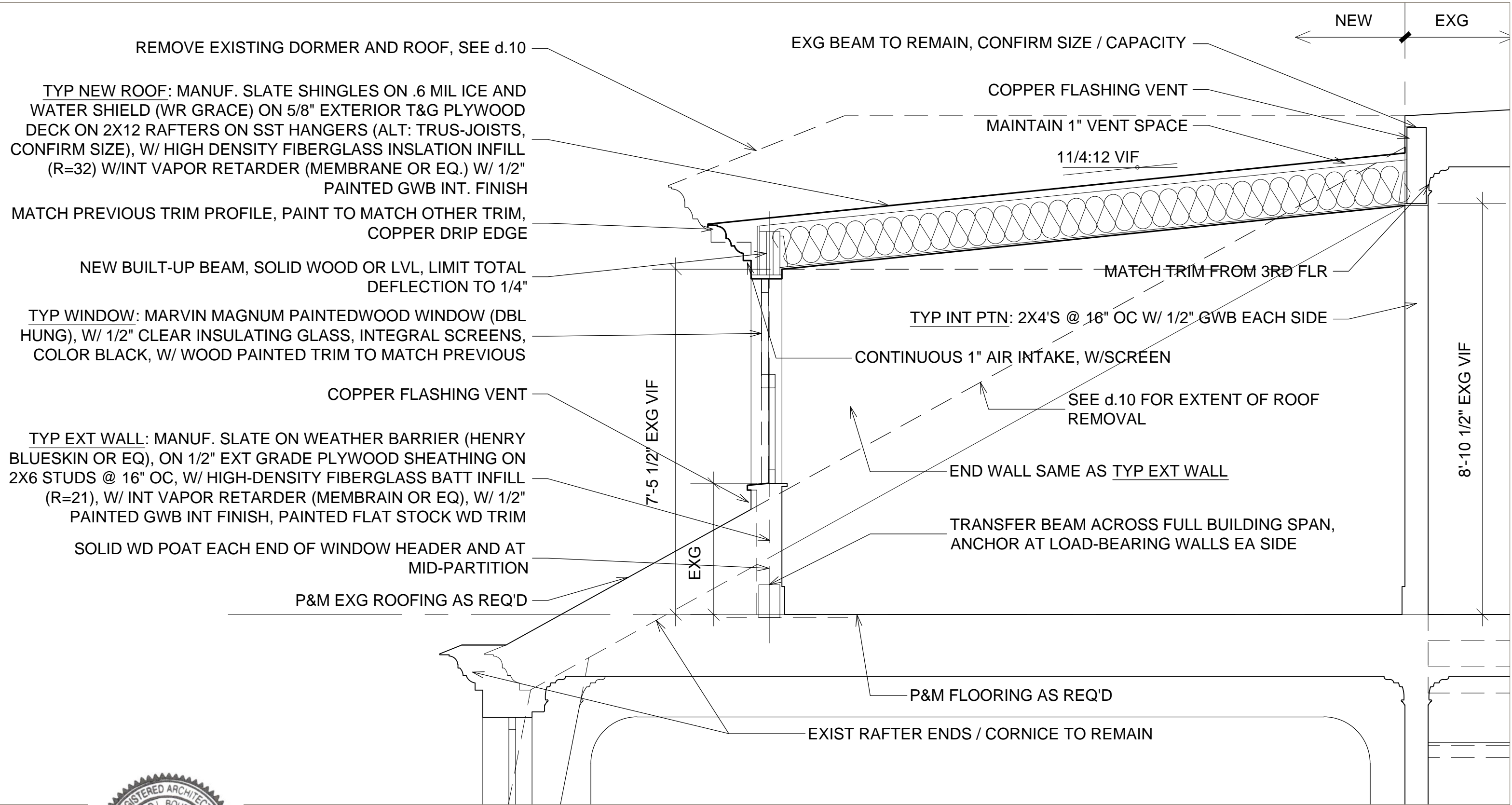

REMOVE EXISTING DORMER AND ROOF, SEE d.10

EXG BEAM TO REMAIN, CONFIRM SIZE / CAPACITY

NEW EXG

TYP NEW ROOF: MANUF. SLATE SHINGLES ON .6 MIL ICE AND WATER SHIELD (WR GRACE) ON 5/8" EXTERIOR T&G PLYWOOD DECK ON 2X12 RAFTERS ON SST HANGERS (ALT: TRUS-JOISTS, CONFIRM SIZE), W/ HIGH DENSITY FIBERGLASS INSLATION INFILL (R=32) W/INT VAPOR RETARDER (MEMBRANE OR EQ.) W/ 1/2" PAINTED GWB INT. FINISH

COPPER FLASHING VENT

MAINTAIN 1" VENT SPACE

1 1/4:12 VIF

MATCH PREVIOUS TRIM PROFILE, PAINT TO MATCH OTHER TRIM, COPPER DRIP EDGE

NEW BUILT-UP BEAM, SOLID WOOD OR LVL, LIMIT TOTAL DEFLECTION TO 1/4"

MATCH TRIM FROM 3RD FLR

TYP WINDOW: MARVIN MAGNUM PAINTEDWOOD WINDOW (DBL HUNG), W/ 1/2" CLEAR INSULATING GLASS, INTEGRAL SCREENS, COLOR BLACK, W/ WOOD PAINTED TRIM TO MATCH PREVIOUS

TYP INT PTN: 2X4'S @ 16" OC W/ 1/2" GWB EACH SIDE

CONTINUOUS 1" AIR INTAKE, W/SCREEN

COPPER FLASHING VENT

SEE d.10 FOR EXTENT OF ROOF REMOVAL

TYP EXT WALL: MANUF. SLATE ON WEATHER BARRIER (HENRY BLUESKIN OR EQ), ON 1/2" EXT GRADE PLYWOOD SHEATHING ON 2X6 STUDS @ 16" OC, W/ HIGH-DENSITY FIBERGLASS BATT INFILL (R=21), W/ INT VAPOR RETARDER (MEMBRANE OR EQ), W/ 1/2" PAINTED GWB INT FINISH, PAINTED FLAT STOCK WD TRIM

END WALL SAME AS TYP EXT WALL

TRANSFER BEAM ACROSS FULL BUILDING SPAN, ANCHOR AT LOAD-BEARING WALLS EA SIDE

SOLID WD POAT EACH END OF WINDOW HEADER AND AT MID-PARTITION

P&M EXG ROOFING AS REQ'D

P&M FLOORING AS REQ'D

EXIST RAFTER ENDS / CORNICE TO REMAIN

1 - new dormer section - 1/2" = 1'-0"



KC Kerby and Feanil Patel | kkerby@gmail.com
 65 Sparks Street | Cambridge | MA | 02138
 November 2, 2022

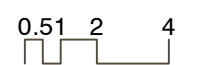

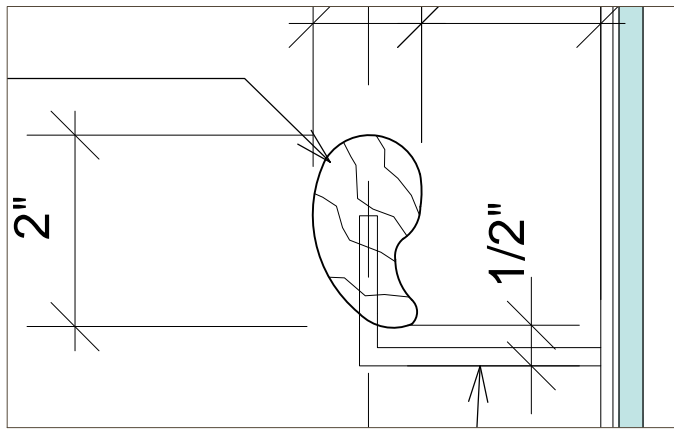

1 - detail at handrail support - 6" = 1'-0"

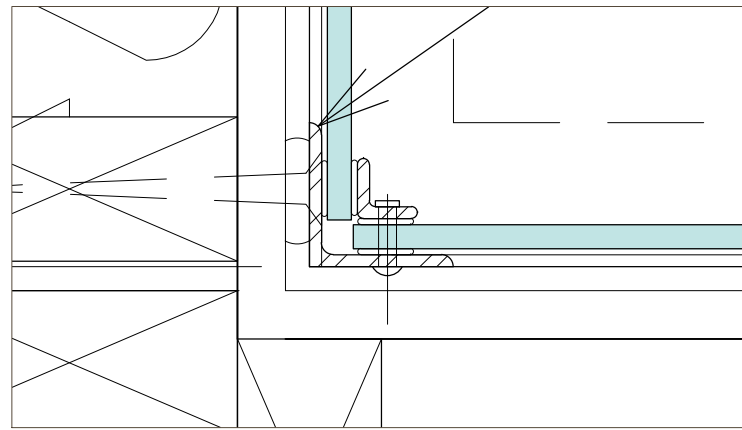

4 - detail at inner corner - 6" = 1'-0"

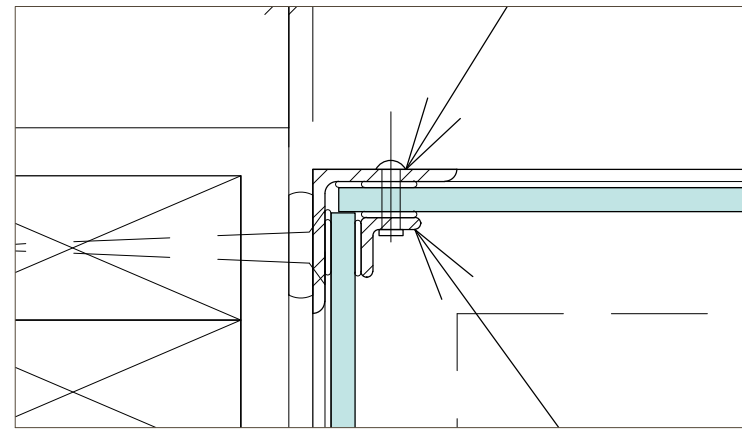

7 - detail at outer support- 6" = 1'-0"

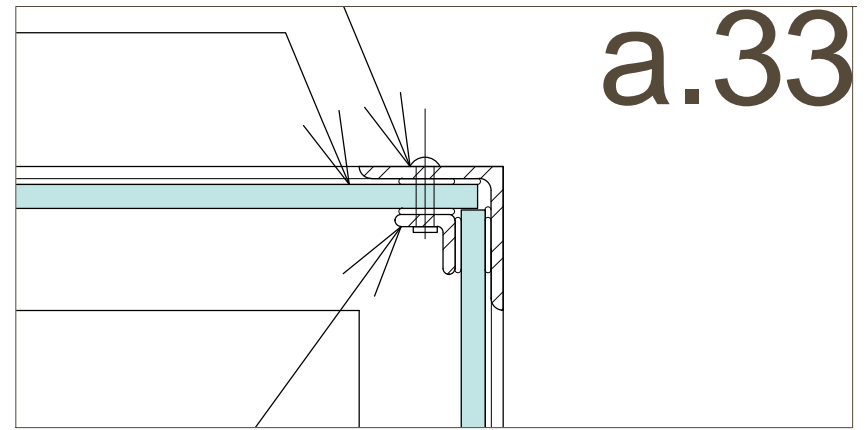

10 - detail at outer top - 6" = 1'-0"

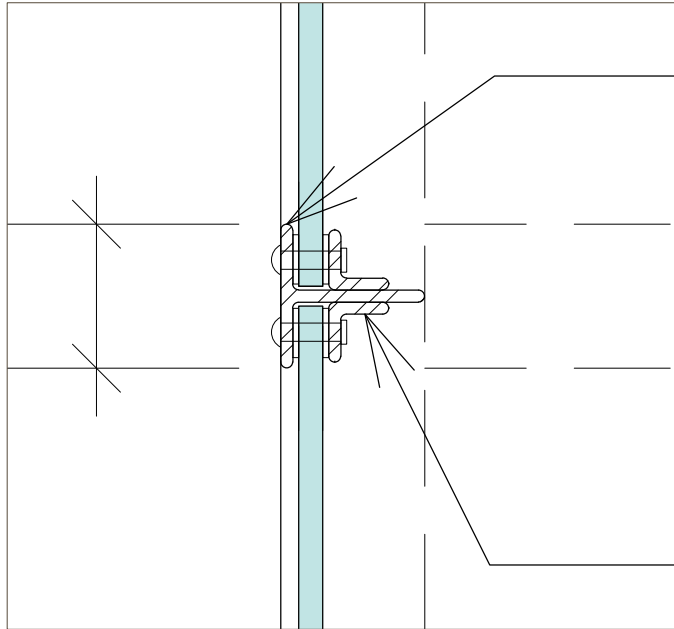

2 - detail at interior skylight post - 6" = 1'-0"

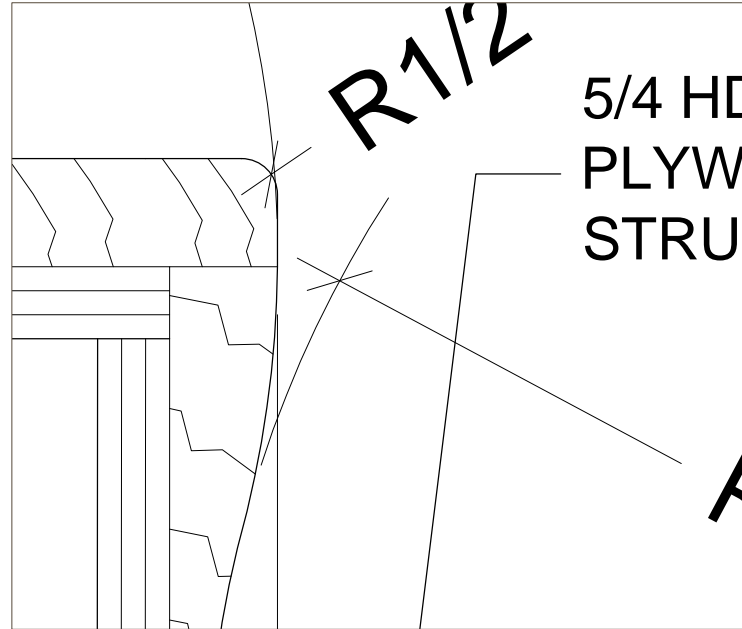

5 - detail at new stair treads/risers - 1 1/2" = 1'-0"

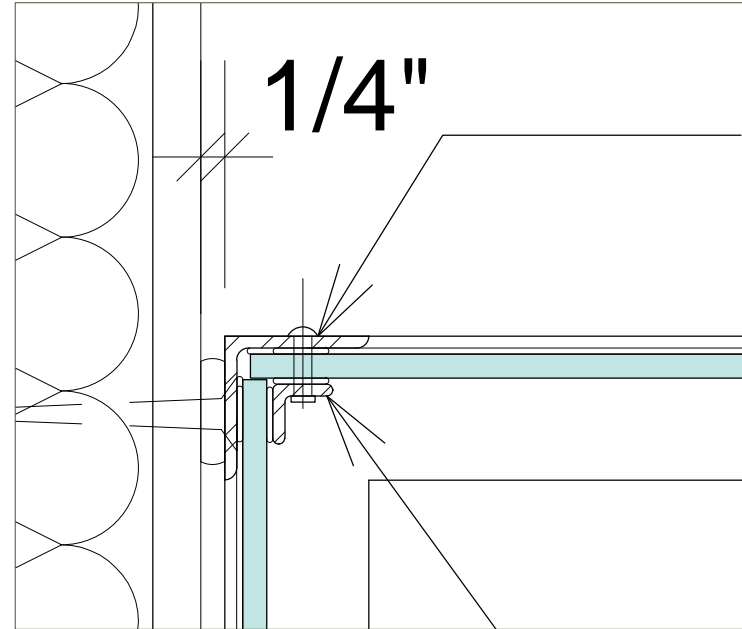

8 - detail at skylight top - 6" = 1'-0"

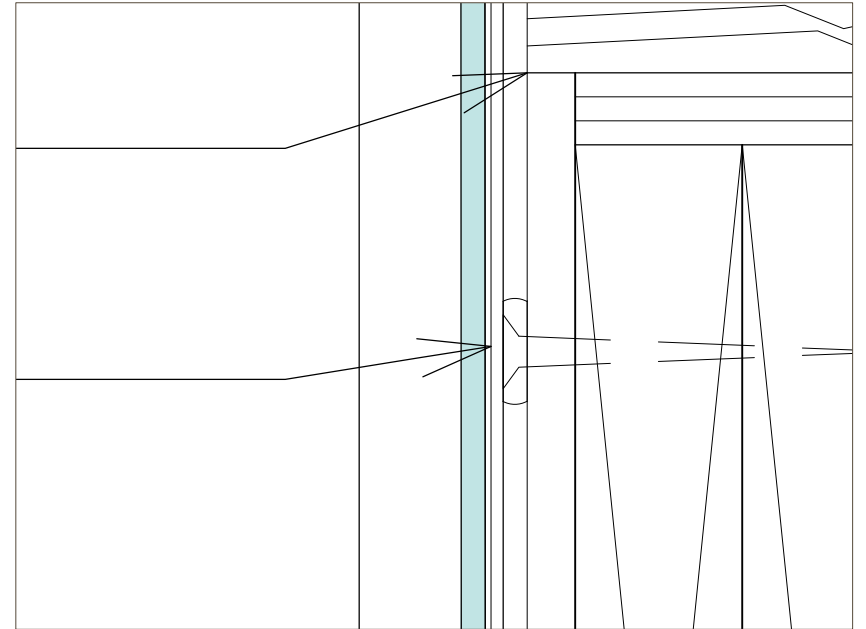

11 - detail at stair support - 1 1/2" = 1'-0"

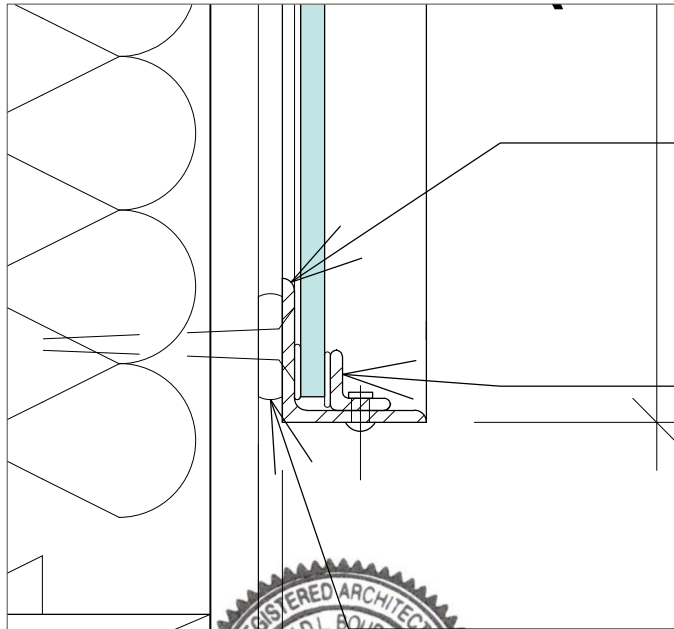

3 - detail at interior skylight saddle - 6" = 1'-0"

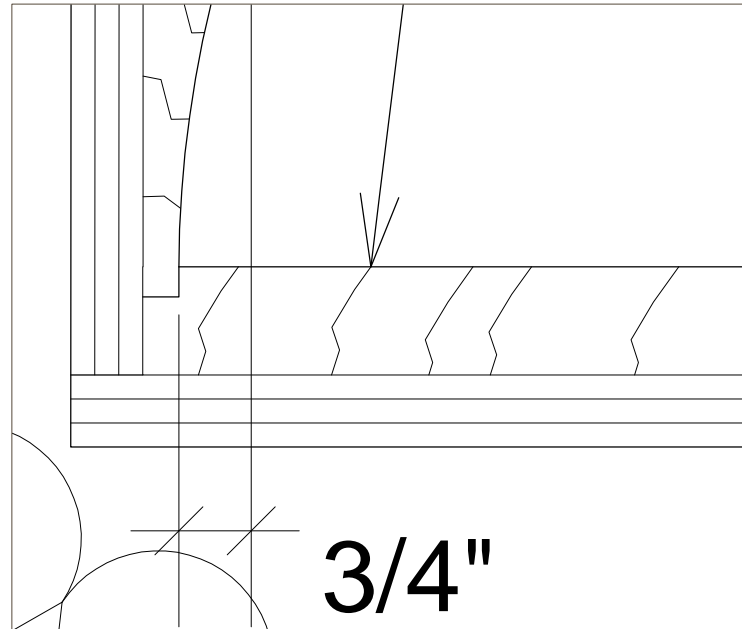

6 - detail at new stair treads/risers - 1 1/2" = 1'-0"

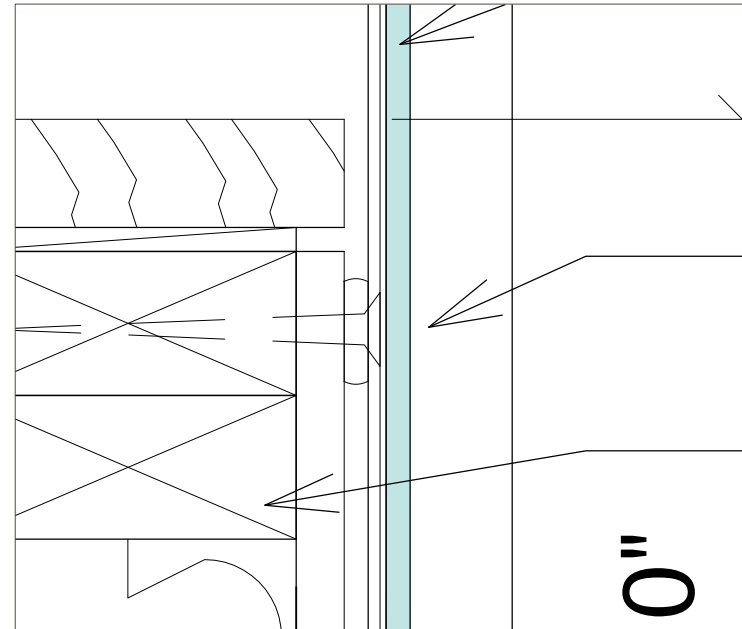

9 - detail at low wall top- 6" = 1'-0"

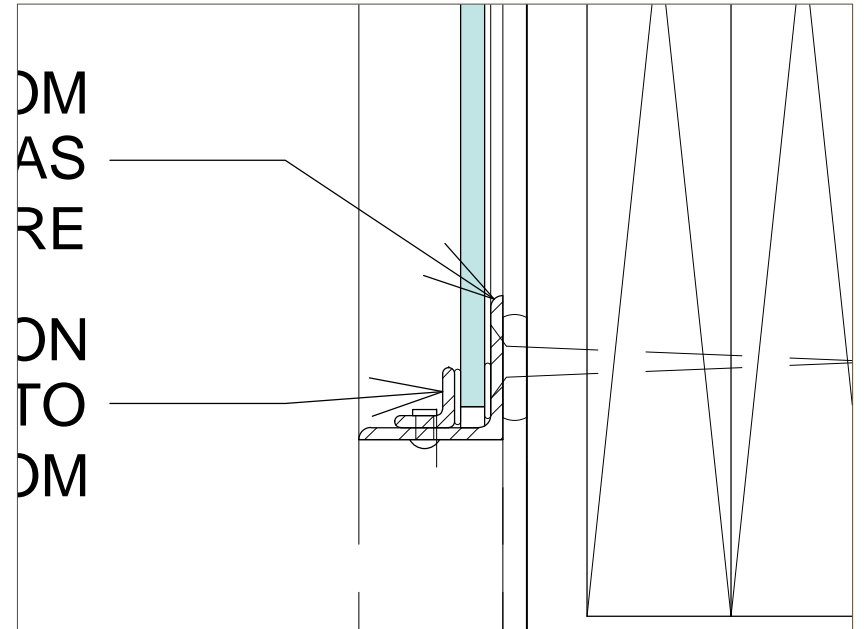

12 - detail at stair support base- 6" = 1'-0"

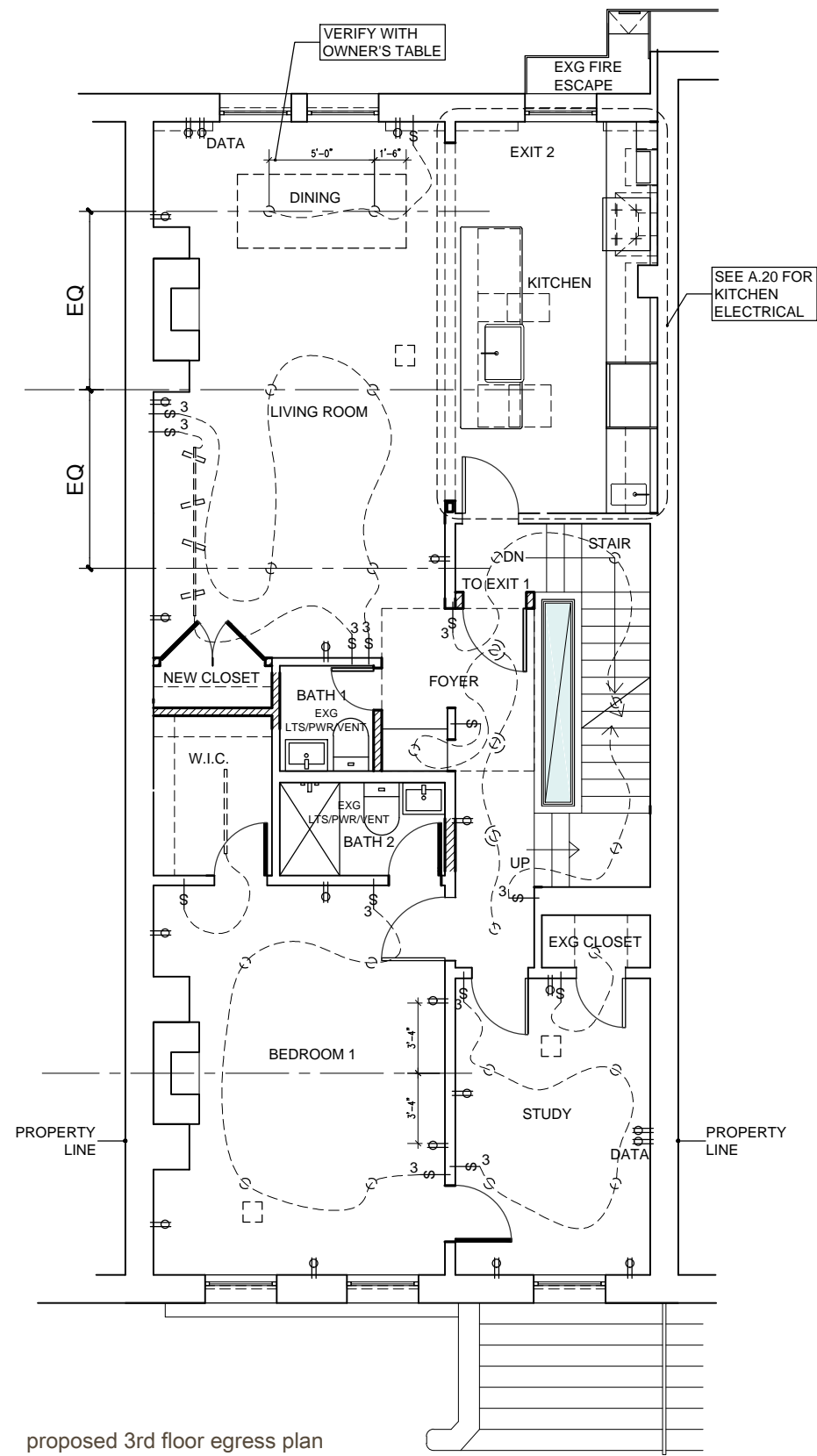

proposed 3rd floor egress plan

ELEC SYMBOLS KEY	
	TRACK LIGHT, LED PODS
	LINEAR LED
	SWITCH
	3-WAY SWITCH
	OUTLET
	TEL/DATA OUTLET
	GROUND FAULT CIRCUIT INTERRUPT
	EXTERIOR GROUND FAULT CIRCUIT INTERRUPT
	6" FLUSH LED PUCK LIGHT
	6" FLUSH LED WALL ADJUSTABLE LIGHT
	6" FLUSH LED WALL SEALED LIGHT
	WIFI ACCESS POINT
	LED LIGHT/EXHAUST FAN, 120 CFM
	EXTERIOR LED WALL SCENCE
	UNDERCOUNTER LED TAPE LIGHT

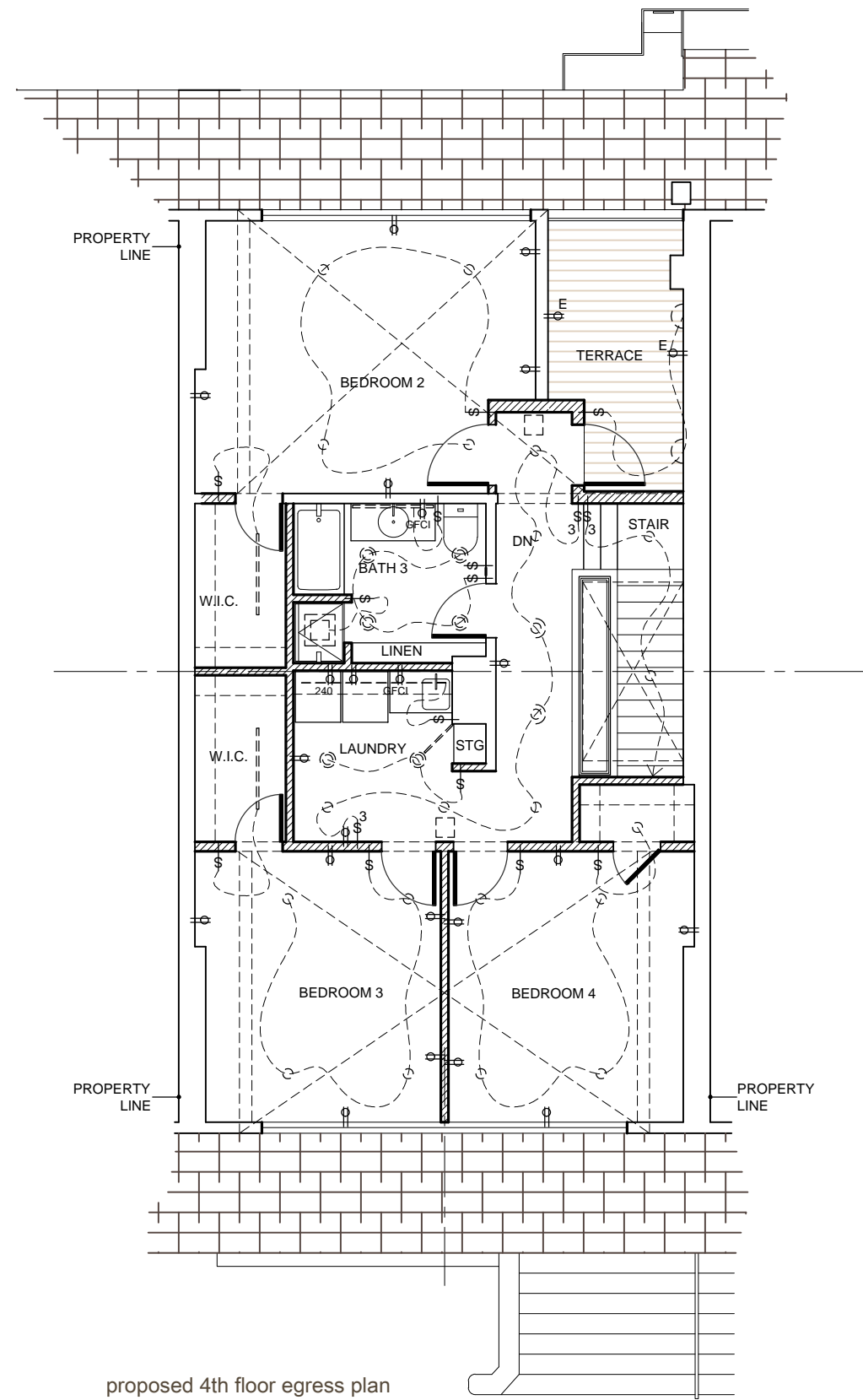

proposed 4th floor egress plan

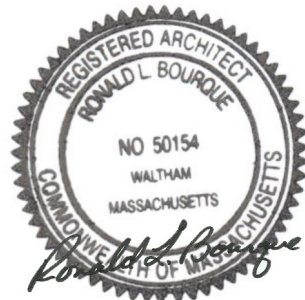

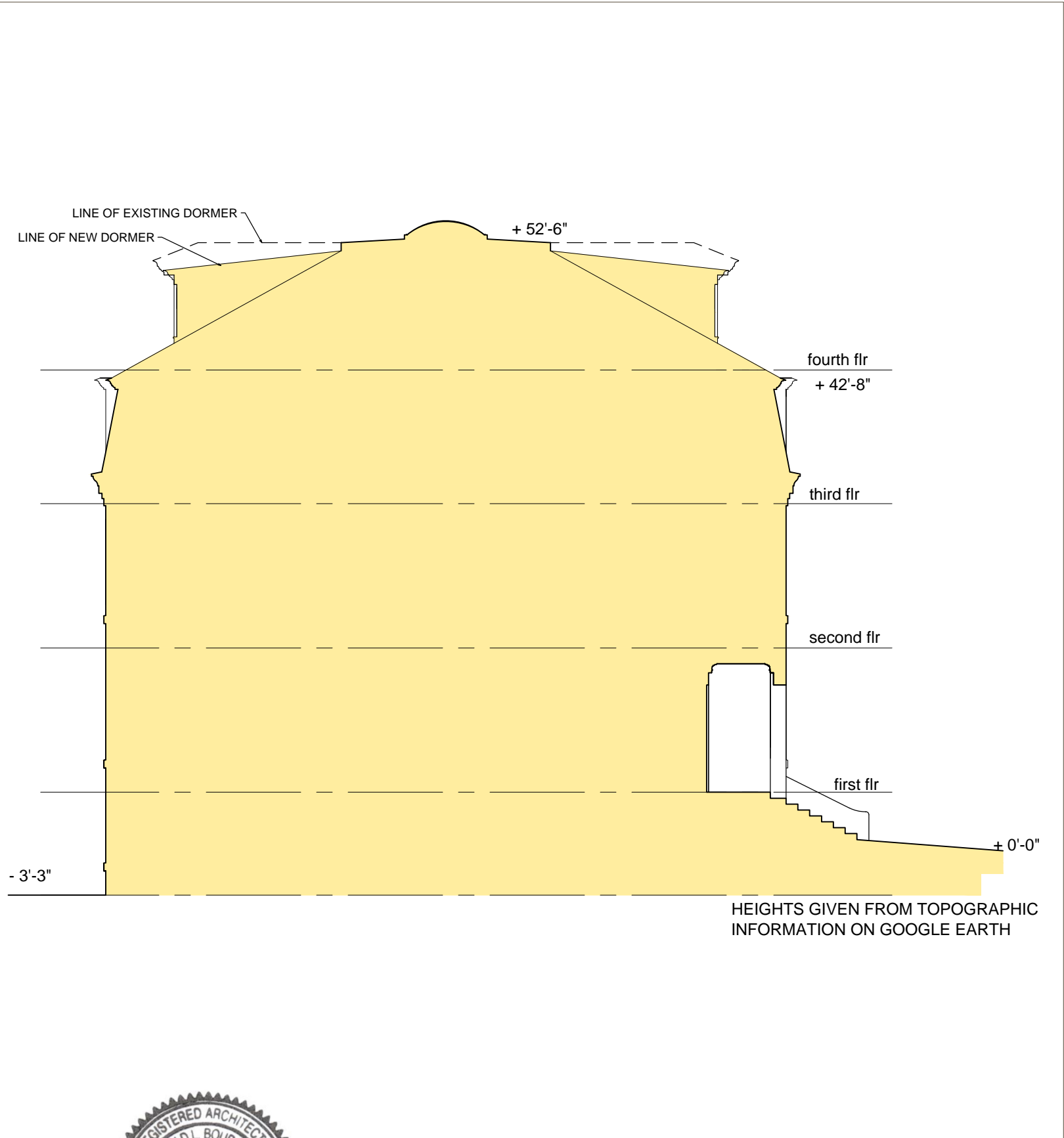

1 - building profile - 3/32" = 1'-0"

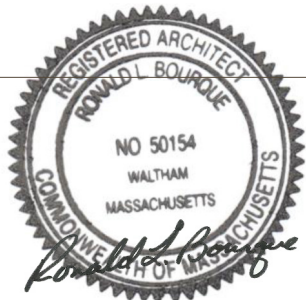

KC Kerby and Feanil Patel | kkerby@gmail.com
65 Sparks Street | Cambridge | MA | 02138
November 2, 2022





1 - VIEW FROM NORTHEAST CORNER, EXISTING



2 - VIEW FROM FRONT YARD, EXISTING



3 - VIEW UP TO ROOF, EXISTING

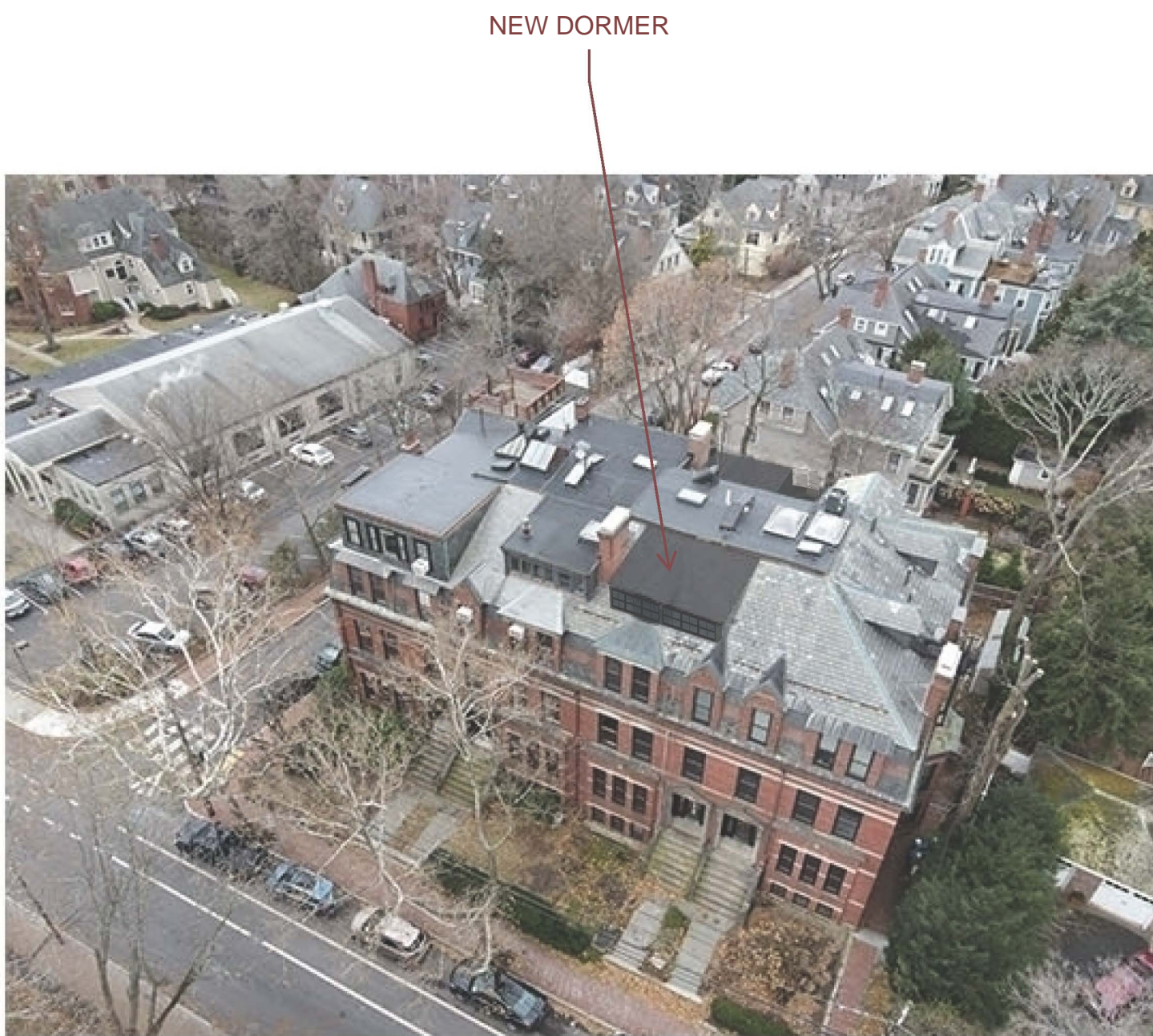

4 - VIEW FROM NORTHEAST CORNER WITH DORMER

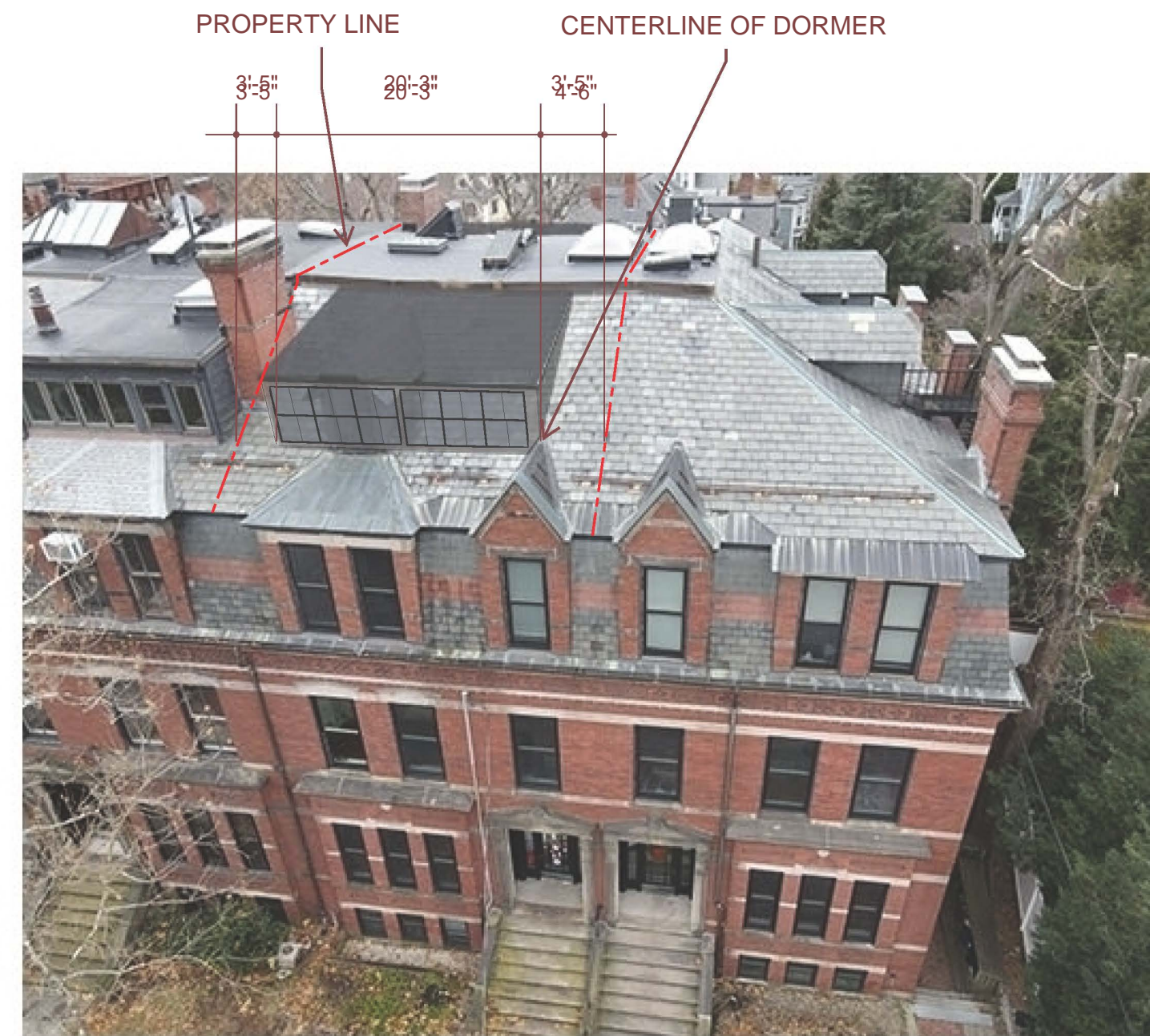

5 - VIEW FROM FRONT YARD WITH DORMER



6 - VIEW UP TO ROOF WITH DORMER

65 SPARKS STREET
 KC AND FEANIL PATEL
 27 FEB 2022



Bourque Design

Architectural Design from
 Conception to Construction

Ron Bourque, Architect
 AIA, NCARB, CS, LEED GA

rbourq@gmail.com
 781-296-6654
 Waltham, MA 02453



EXHIBIT-1
VIEW FROM FRONT YARD



1 - NORTHWEST CORNER, EXISTING



2 - REAR YARD WEST VIEW, EXISTING



3 - REAR YARD VIEW UP, EXISTING



4 - NORTHWEST CORNER WITH DORMER / TERRACE

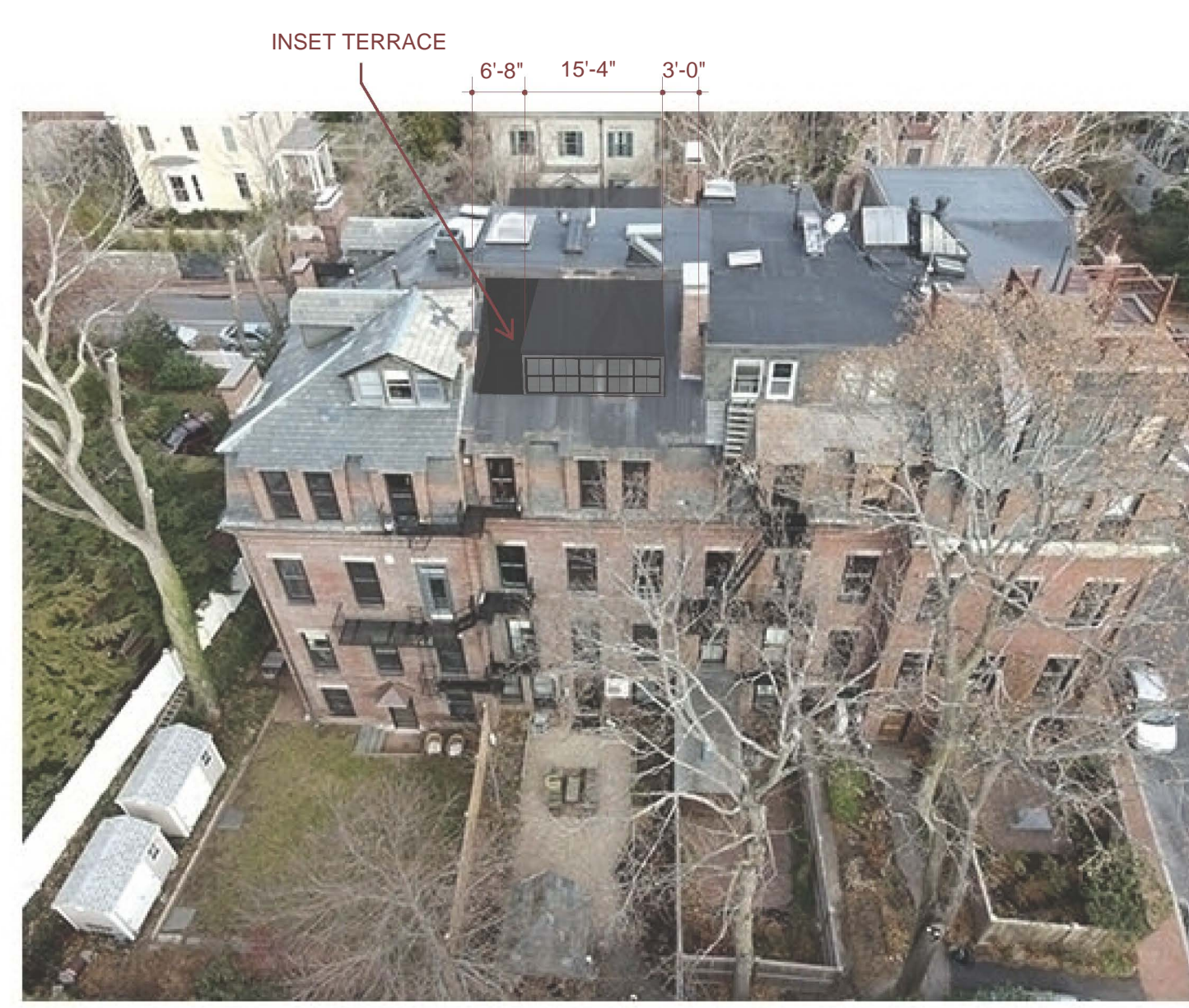

5 - REAR YARD WEST VIEW WITH DORMER / TERRACE



6 - REAR YARD VIEW UP WITH DORMER / TERRACE

65 SPARKS STREET
KC AND FEANIL PATEL
27 FEB 2022



Bourque Design

Architectural Design from
Conception to Construction

Ron Bourque, Architect
AIA, NCARB, CS, LEED GA

rbourq@gmail.com
781-296-6654
Waltham, MA 02453



EXHIBIT-2
VIEW FROM REAR YARD



1 - VIEW OF DORMER FROM SPARKS STREET, FRONT YARD



2 - VIEW OF DORMER FROM BACK YARD AT 65 SPARKS STREET

65 SPARKS STREET
 KC AND FEANIL PATEL
 27 FEB 2022



Bourque Design

Architectural Design from
 Conception to Construction

Ron Bourque, Architect
 AIA, NCARB, CS, LEED GA

rbourq@gmail.com
 781-296-6654
 Waltham, MA 02453



EXHIBIT - 3
SKETCH VIEWS

January 2, 2023

Re: Case #206407 - 65 Sparks Street top floor renovation

We are writing in support of the above captioned project. From 2009 - 2021, we lived in #2 at 65 Sparks Street as renters, and since 2021, we own and are renovating #3 for our residence at 63 Sparks Street. We're very familiar with the neighborhood and the rowhouse buildings. We are committed to keeping it a nice place to live. Because it is a collection of flats, the row is a bit of an anomaly amongst all the larger homes in the area. It is nice that the new owners at #65 are keeping it as flats. We like the diversity it brings.

It always seemed a little unfair that #65 hadn't put dormers on the top - the rest of the row has done, so in fact this renovation will bring it into harmony with the other three townhouses in the row. It will also be good because the roof at #65 is at present in terrible condition. To fix it will alleviate the terrible ice problem that builds up because at present the roof isn't insulated - and all that ice lands from time to time on the front and back entries of the building. After many years of DIY interventions by the previous owner, it is great to see the building get professional attention at last.

Our buildings at 61-67 Sparks are a unique address in West Cambridge. When you say you live at that address, everyone seems to know and love the the buildings. The proposed changes will leave them just as charming. They will make a great difference to the comfort of the building for the inhabitants of the third floor at #65. As is, it really isn't big enough for a family, and renovated as proposed, it will be. There isn't a problem for parking, if that is a concern? In this area of Sparks there is plenty of curb space.

We support a decision to grant a permit for the Patels' project. If you have any questions, please do not hesitate to contact us.

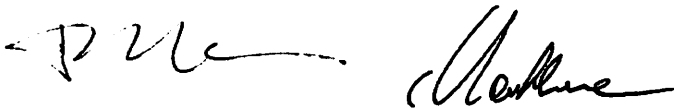

Toni Lee and Charles de Lantsheere
tldlantsheere@gmail.com
chdlansheere@gmail.com

CHARLES AND TONI LEE DE LANTSHEERE
63 Sparks Street, Cambridge MA 02138

Letter of Support

David Stang <daviddstang@gmail.com>

Mon 1/2/2023 3:58 PM

To: Adam Dash <dash@adamdashlaw.com>

Cc: feanil@gmail.com <feanil@gmail.com>

Dear Mr. Dash,

I am writing to add my support to the project currently proposed for 65 Sparks Street, Apt. 4, Cambridge MA 02138 (case number 206407).

As the resident owner of 63 Sparks Street, Apt. 2, I am a direct abutter of the project. I have lived at this address for 27 years, having purchased my apartment in 1996.

Please don't hesitate to let me know if there is any further information you would like from me.

Sincerely,

David D. Stang

proposed renovations for 65 Sparks St. Apt. 4 (case number 206407)

carla procaskey <carla.procaskey@gmail.com>

Thu 1/5/2023 12:16 PM

To: Adam Dash <dash@adamdashlaw.com>

To Whom It May Concern,

We, Tony Flanders and Carla Procaskey, live at 61 Sparks St. #3, part of the four townhouses that comprise 61-67 Sparks St. We have lived at 61 Sparks St for 30 years.

We support the renovations being proposed for 65 Sparks St. Apt 4. The current roofline of the four units (61-67) on Sparks St. is rather haphazard. Since the upper level of these buildings can't be restored to its original configuration, we think the proposed renovations will make the general roofline look more coherent in both the front and back of the building. We think this would be a desirable change.

Carla Procaskey
Tony Flanders

case number 206407

Richard Hill <richill_53@hotmail.com>

Sat 1/7/2023 12:52 PM

To: Adam Dash <dash@adamdashlaw.com>

Hello,

My name is Richard Hill. I live at 63 Sparks St, Unit 4, which abuts 65 Sparks St. Apt 4. I have lived here since 1997. I support the proposal for 65 Sparks St Apt 4 (case number 206407).

Cordially,

Richard Hill

63 Sparks St, Unit 4

Cambridge, MA 02138

To whom it may concern:

My neighbors KC and Feanil Patel are requesting a variance to construct 2 dormers front and rear at their top-floor property in 65 Sparks St. I have seen the photographs and drawings that are being submitted with this application and write to say that I support the project strongly. The proposed front dormer, in particular, will improve the appearance of the building from the street.

I own and have lived in the top-floor unit of the 61 Sparks Street Condominium since 1974. This apartment was created many years before that by the construction of a shed dormer on front part of the building, and I improved upon that by having similar construction done in the rear. Two years before that, in 1971, 2 dormers were built front and rear on the top floor at 63 Sparks St, when it was converted to a condominium, to create an apartment in what had previously been attic space. The Patel's proposal is very much in keeping with the best use of space in this unique block of buildings.

Respectively submitted,

A handwritten signature in black ink that reads "David H. Evans". The signature is written in a cursive, flowing style.

David H. Evans

January 4, 2023

65 Sparks front view (existing), March 21, 3:00pm



65 Sparks front view (existing), June 21, 3:00pm



65 Sparks front view (existing), September 21, 3:00pm



65 Sparks front view (existing), December 21, 3:00pm



65 Sparks front view, March 21, 9:00am

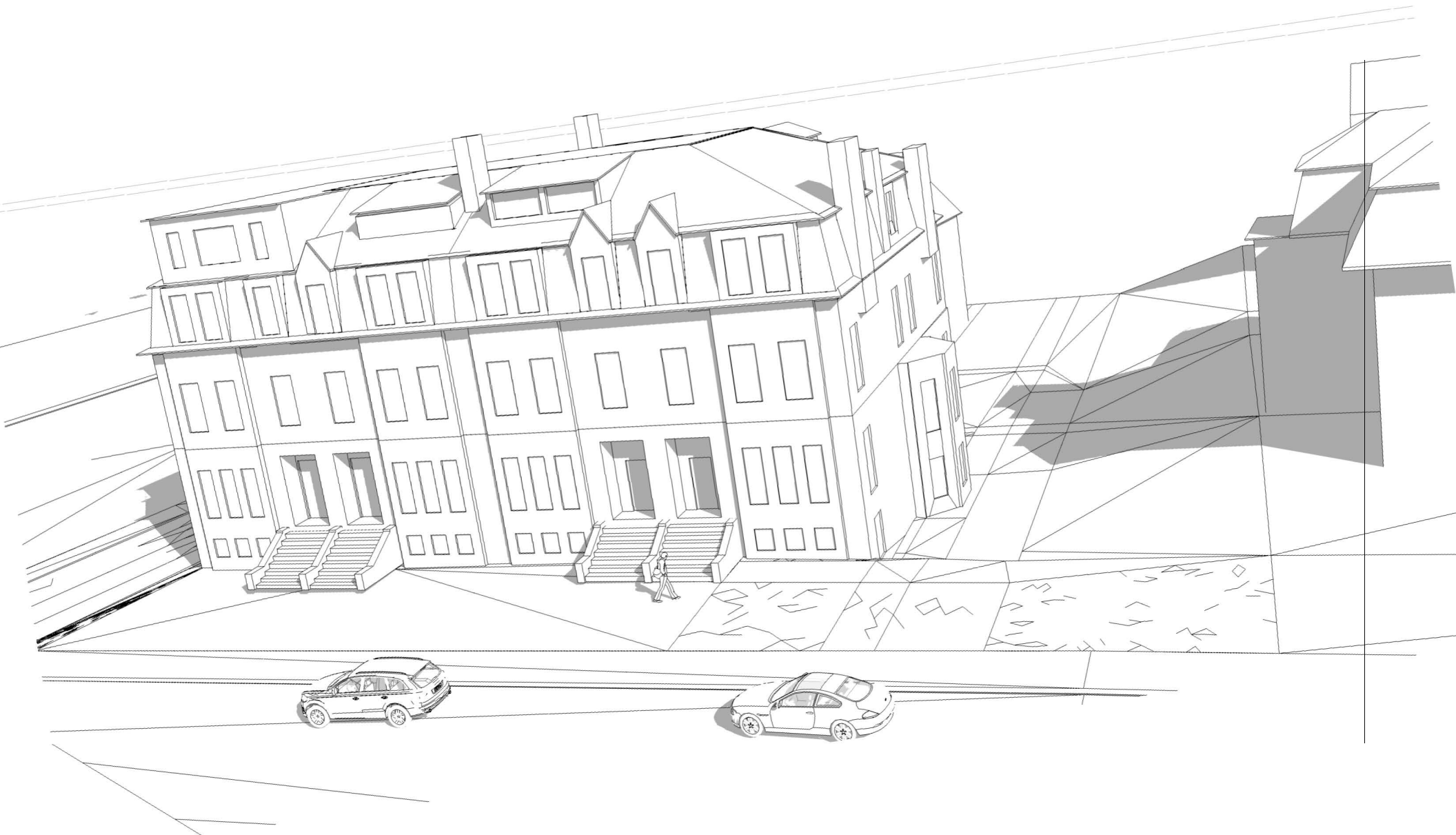

65 Sparks front view, March 21, 12:00pm



65 Sparks front view, March 21, 3:00pm

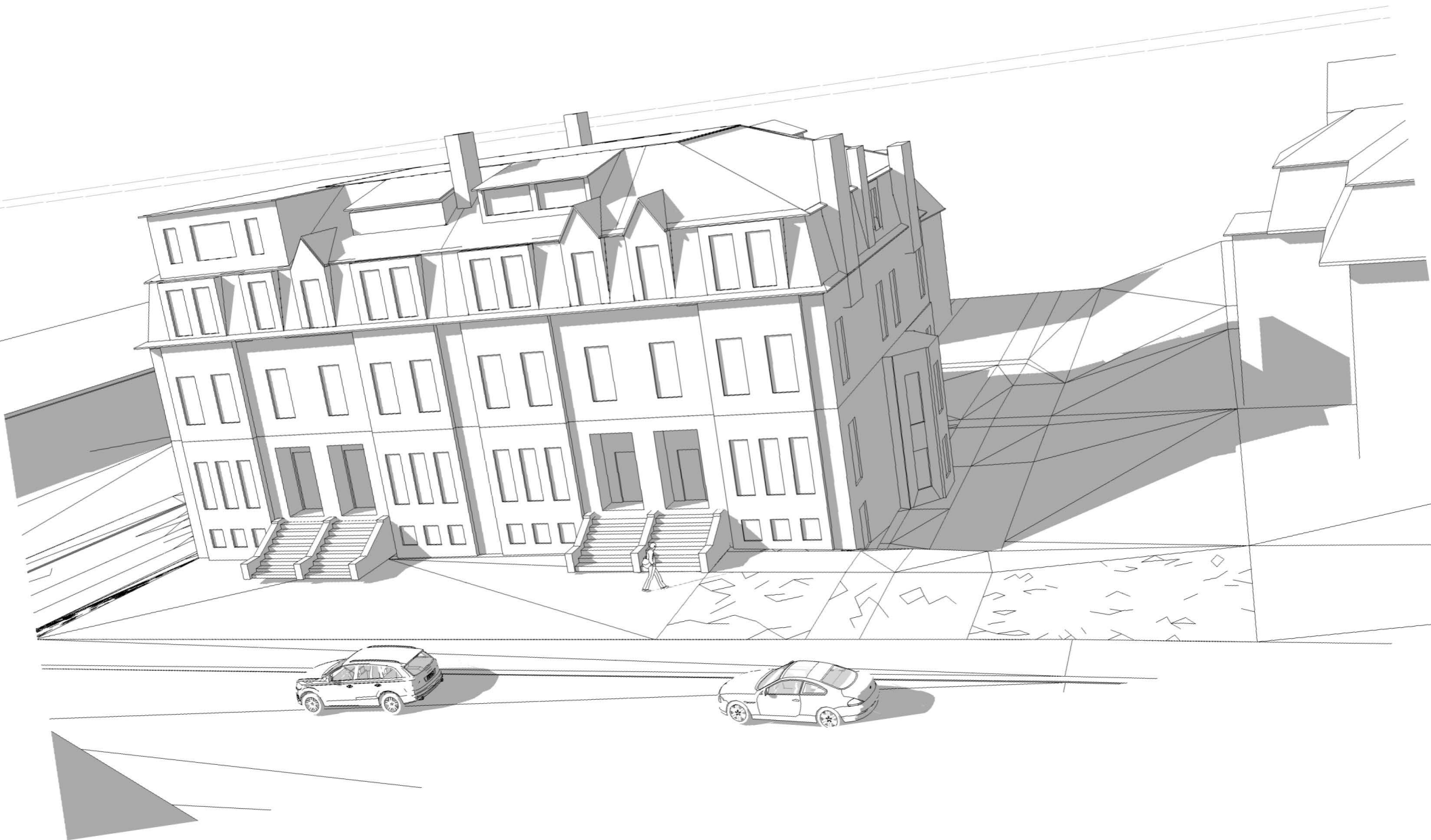

65 Sparks front view, June 21, 9:00am

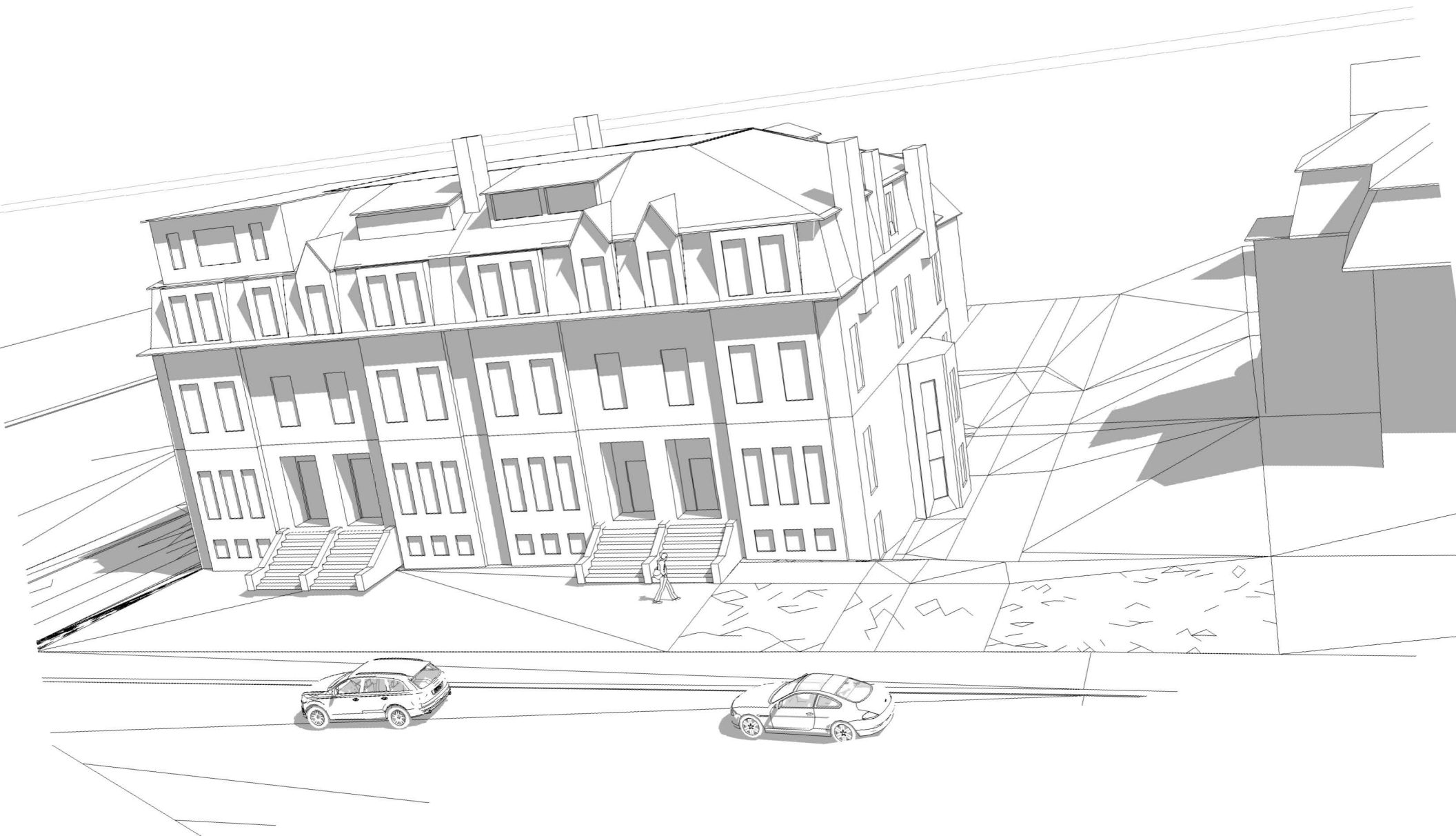

65 Sparks front view, June 21, 12:00pm



65 Sparks front view, June 21, 3:00pm



65 Sparks front view, September 21, 9:00am

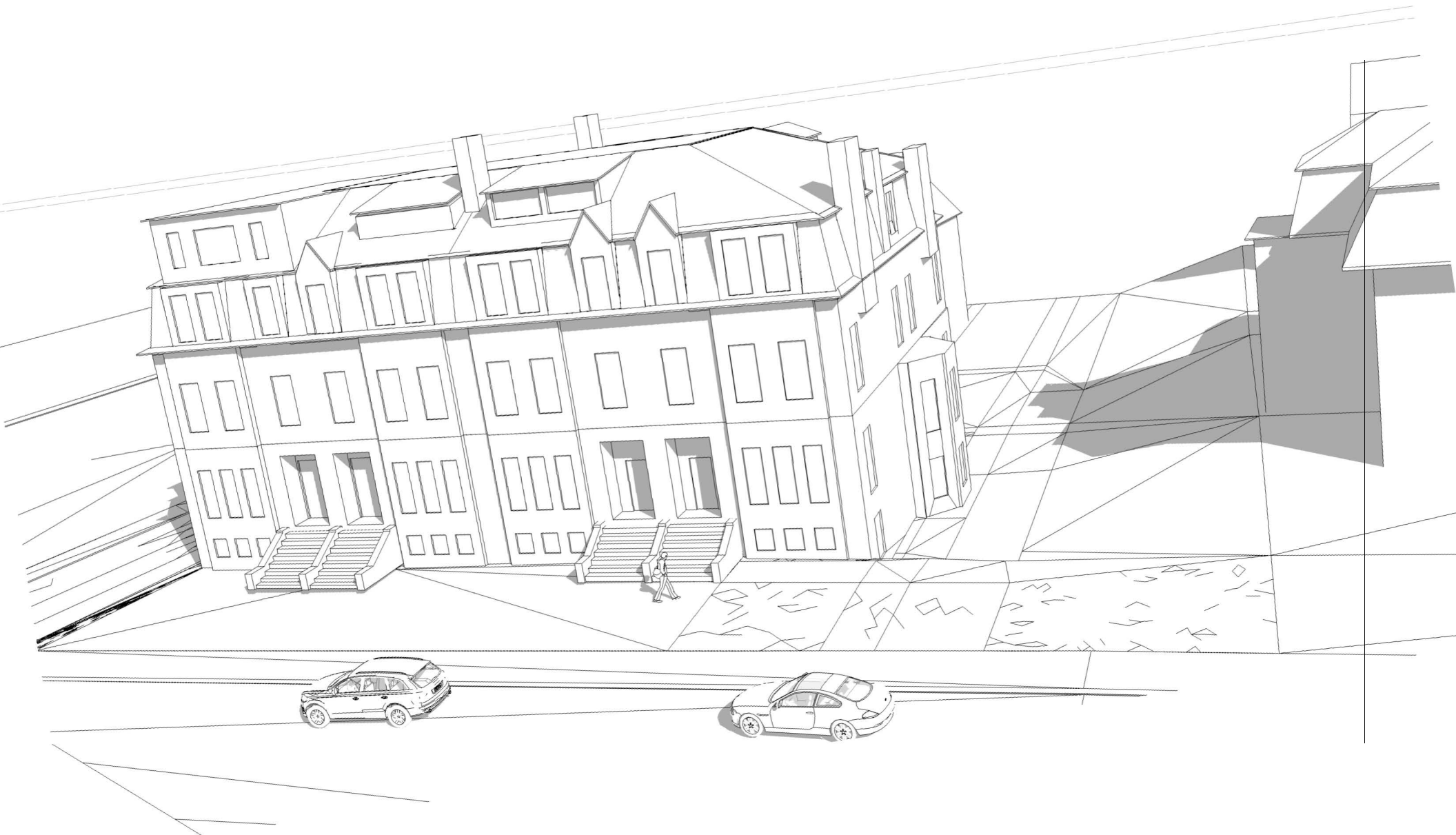

65 Sparks front view, September 21, 12:00pm



65 Sparks front view, September 21, 3:00pm

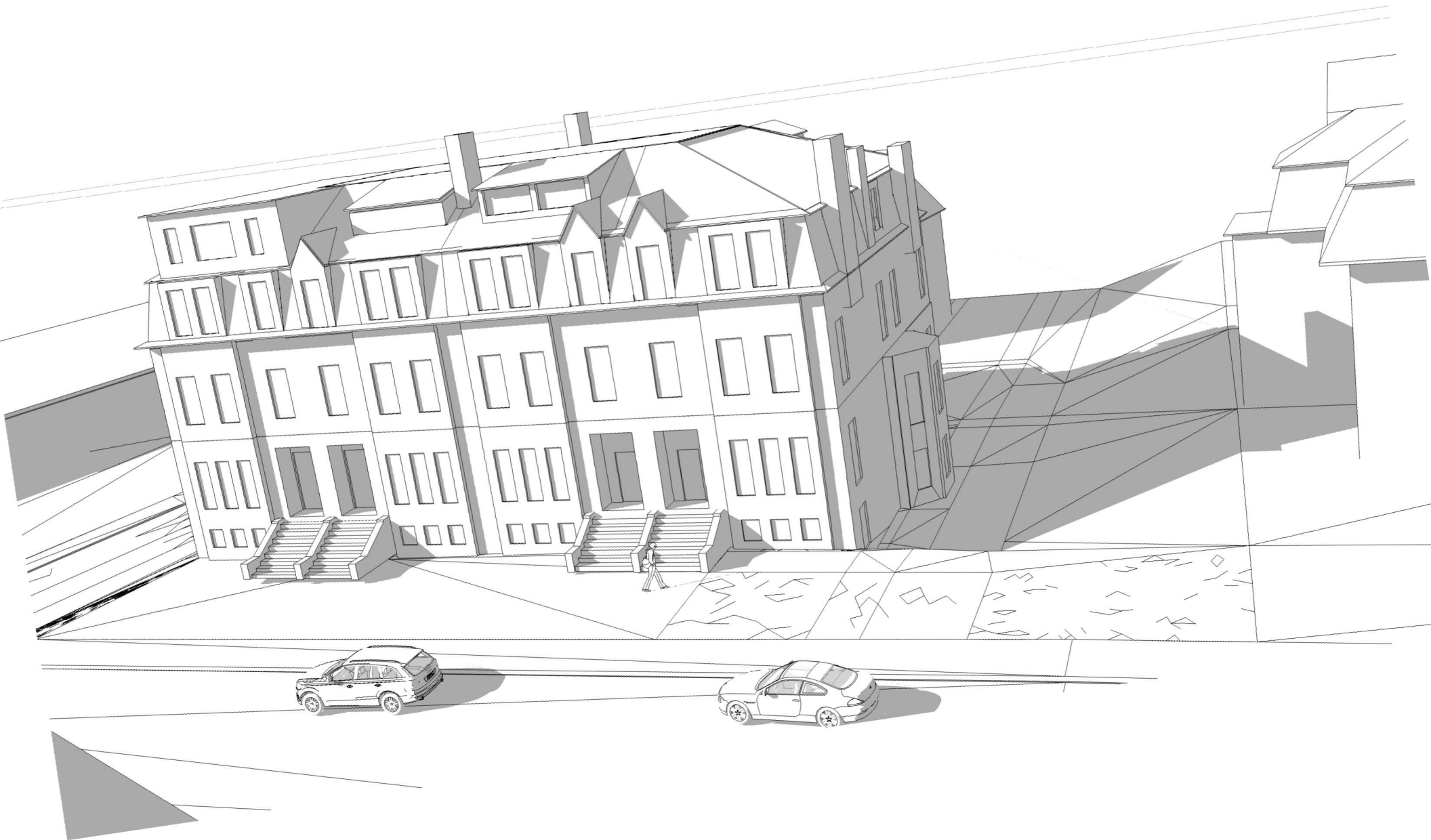

65 Sparks front view, December 21, 9:00am

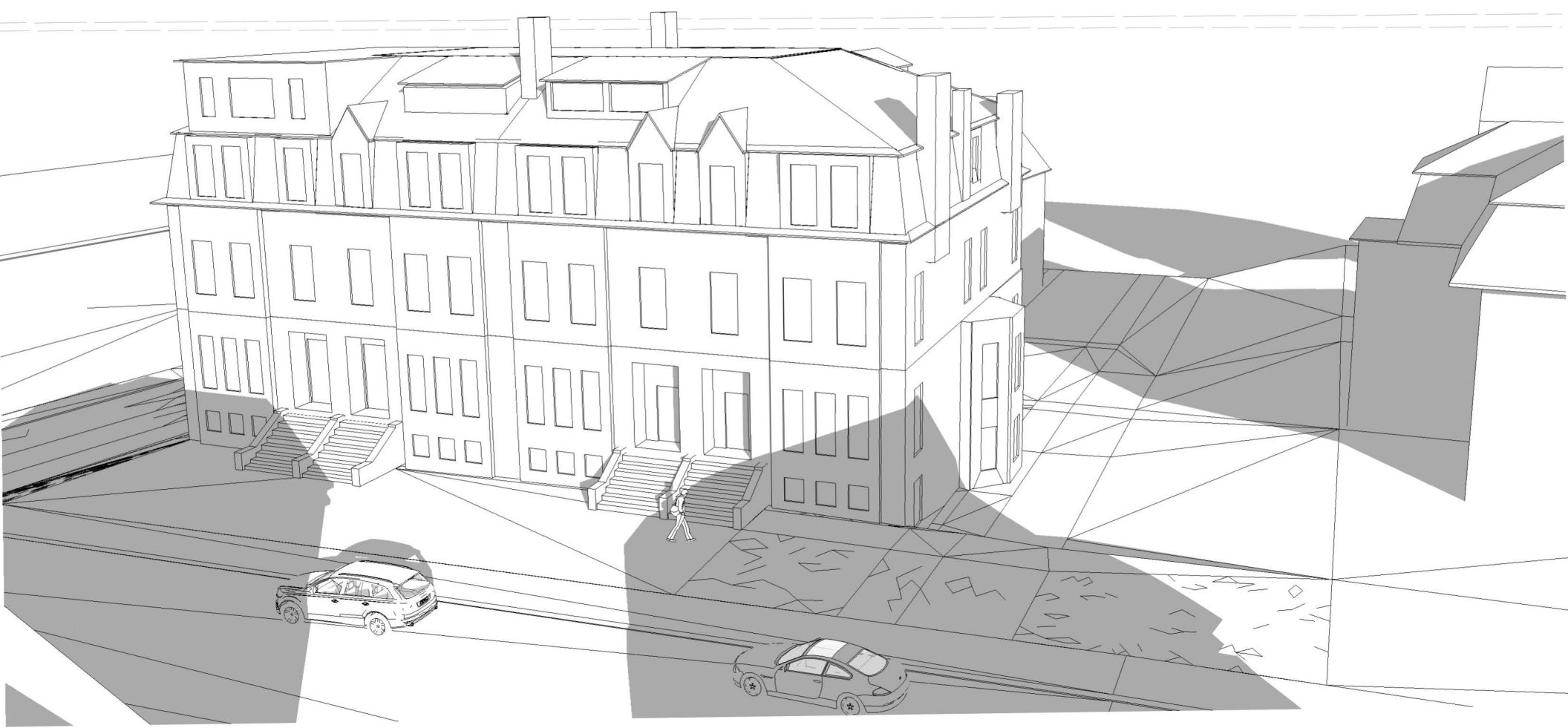

65 Sparks front view, December 21, 12:00pm

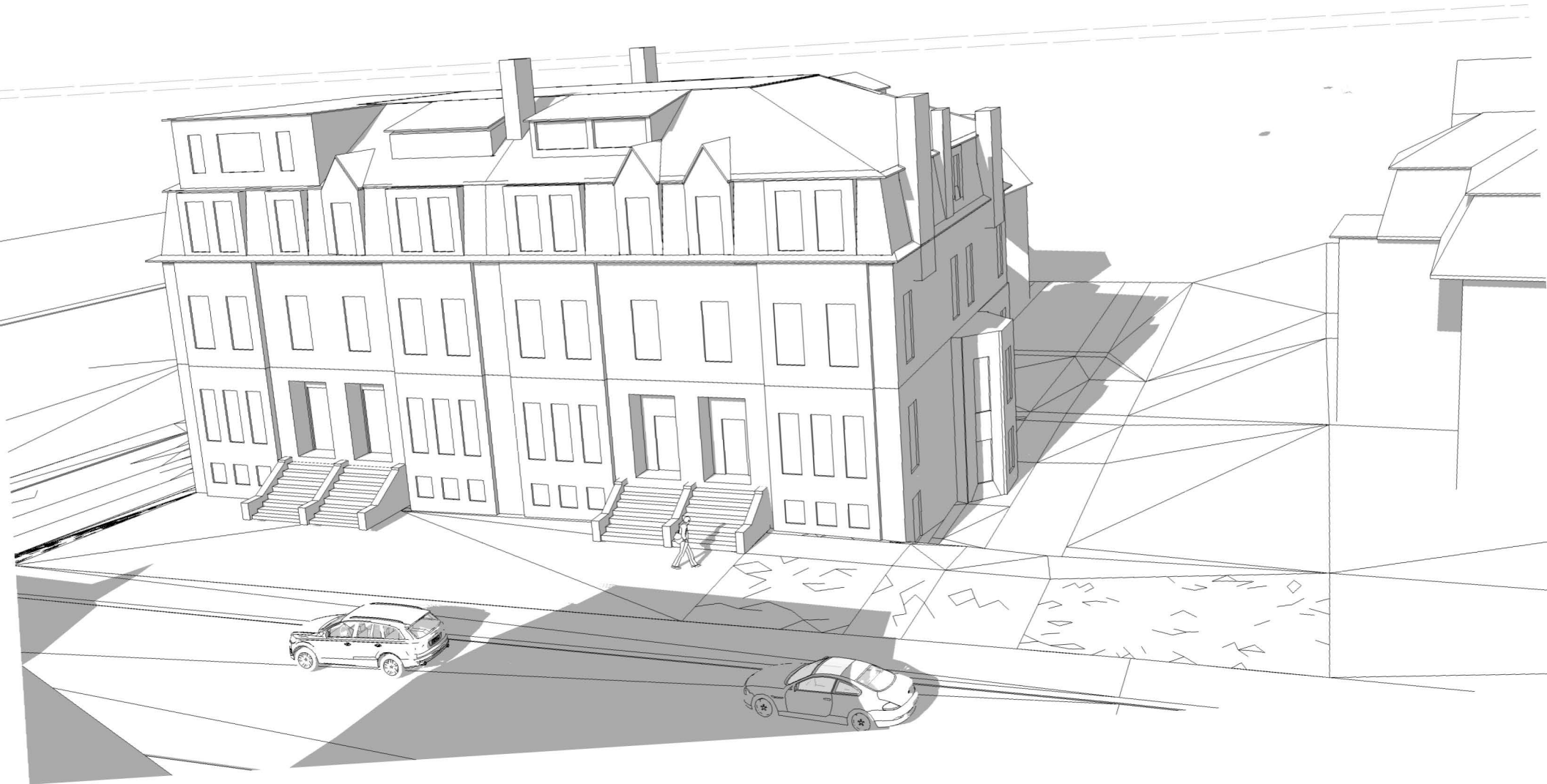

65 Sparks front view, December 21, 3:00pm

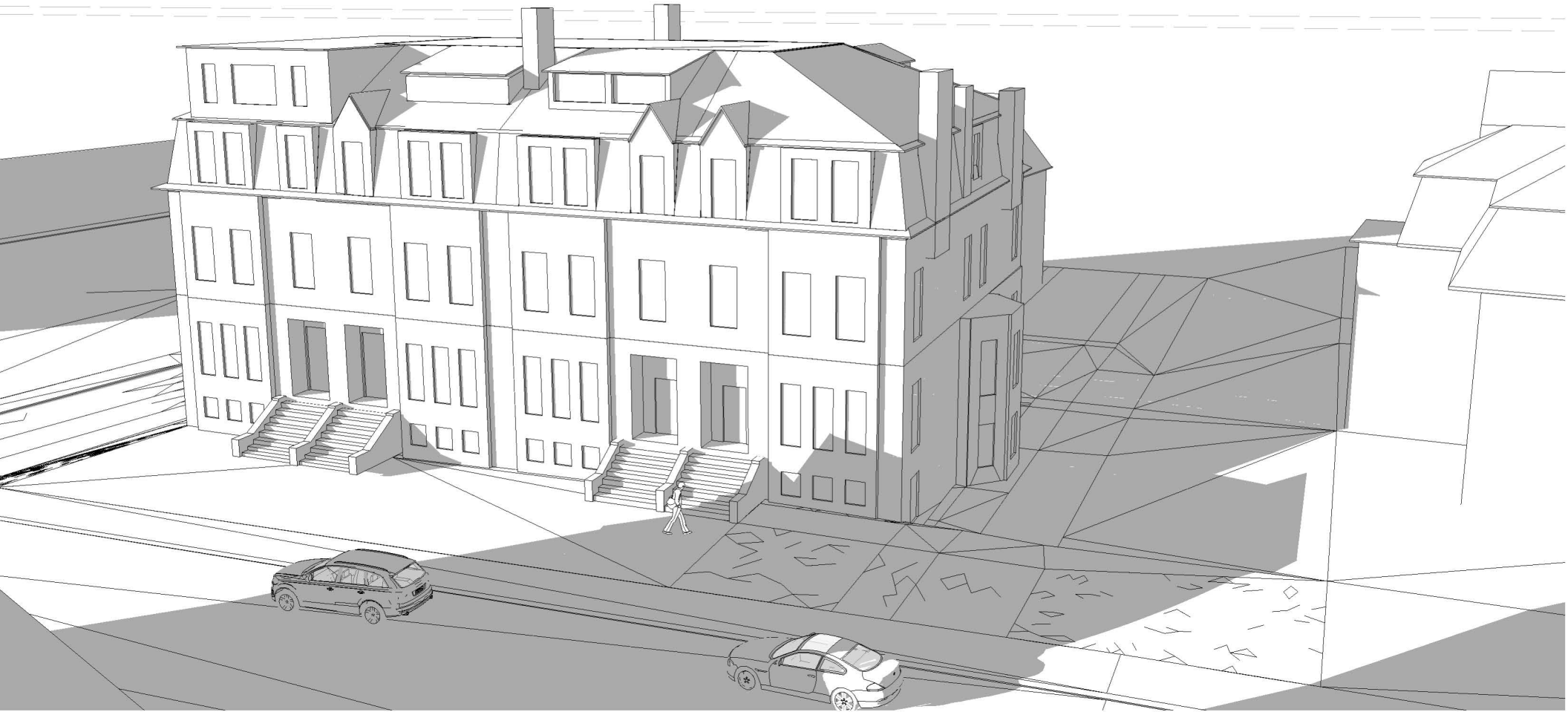

65 Sparks rear view, March 21, 9:00am

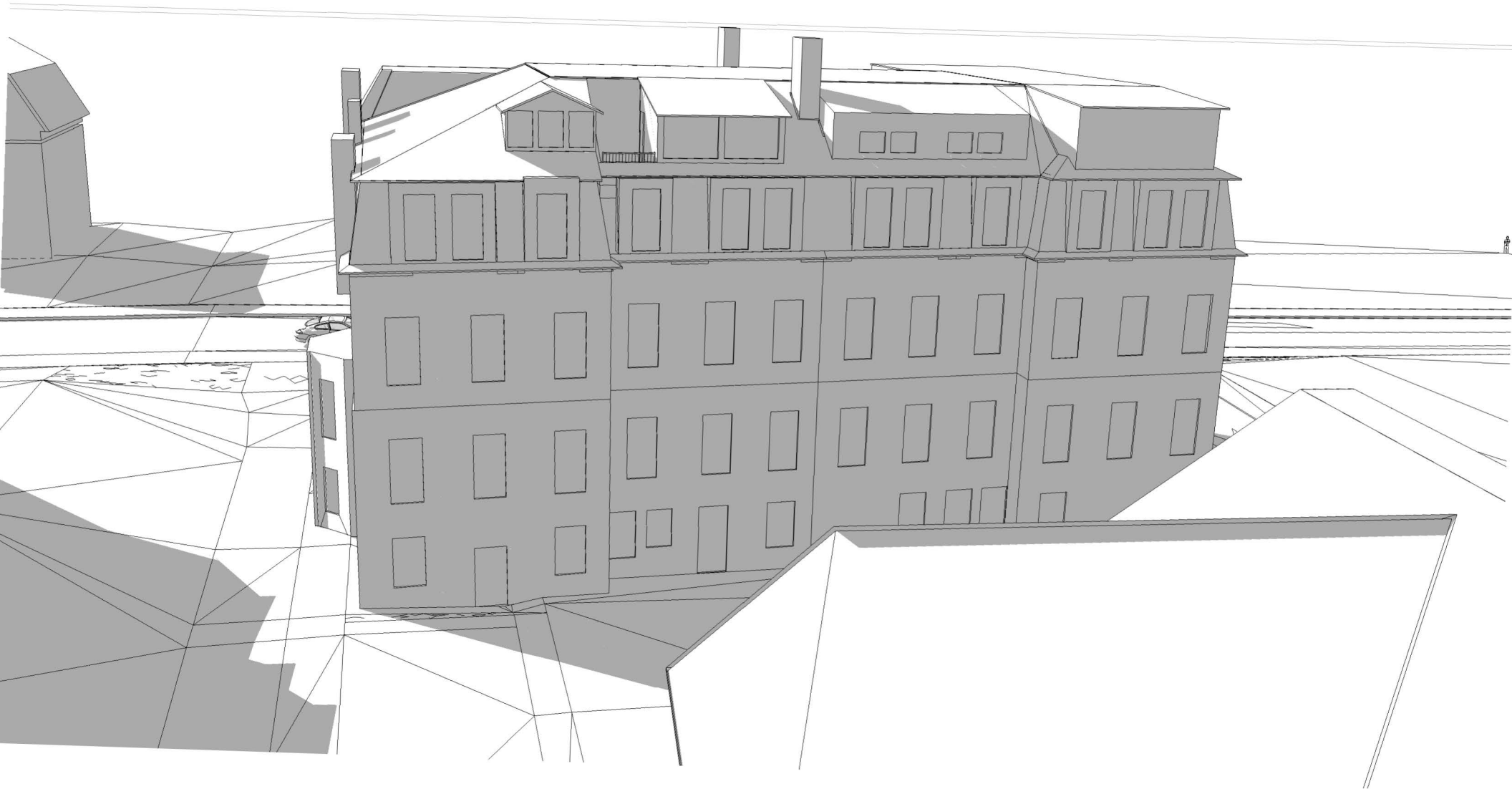

65 Sparks rear view, March 21, 12:00pm

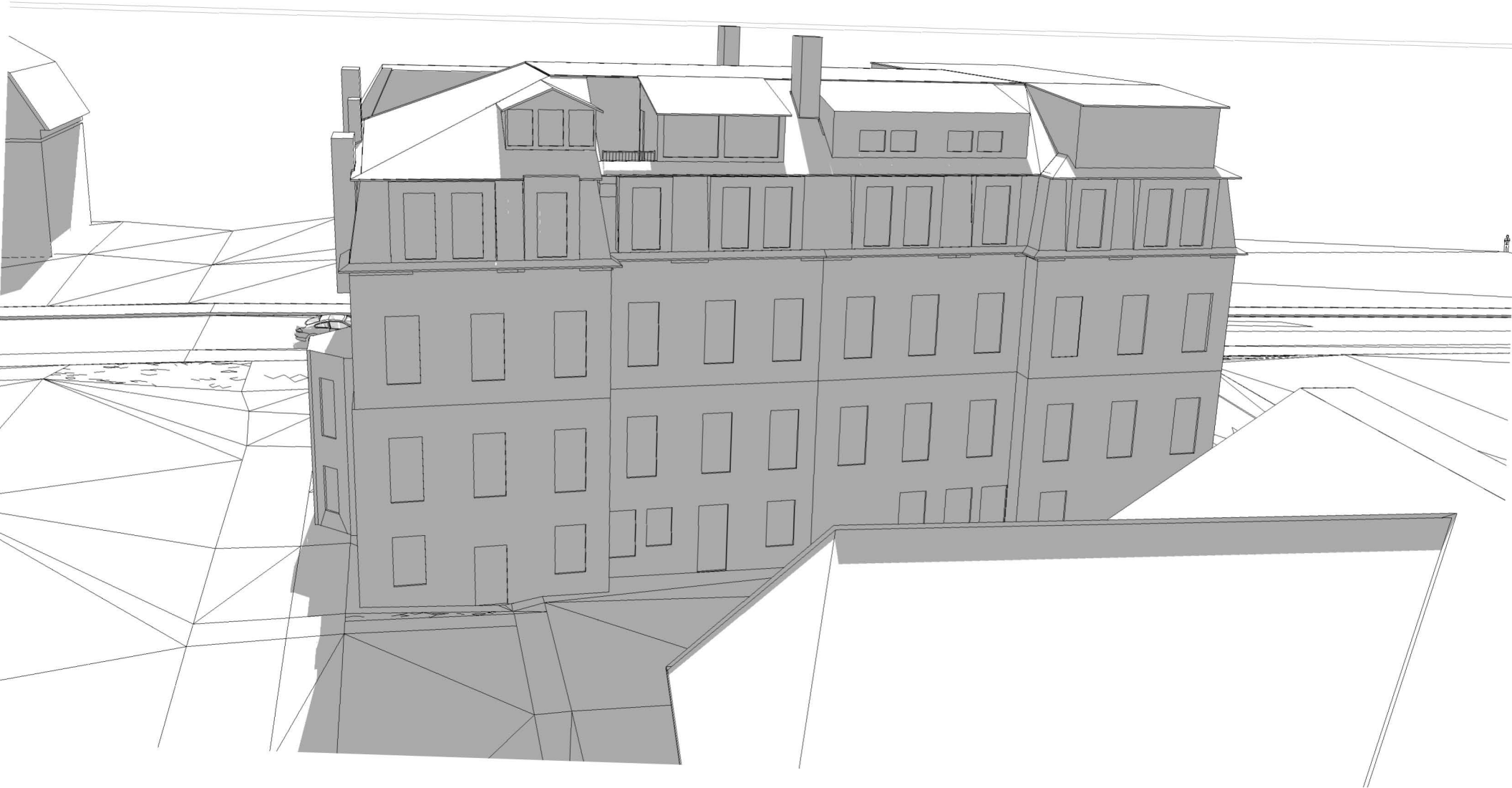

65 Sparks rear view, March 21, 3:00pm

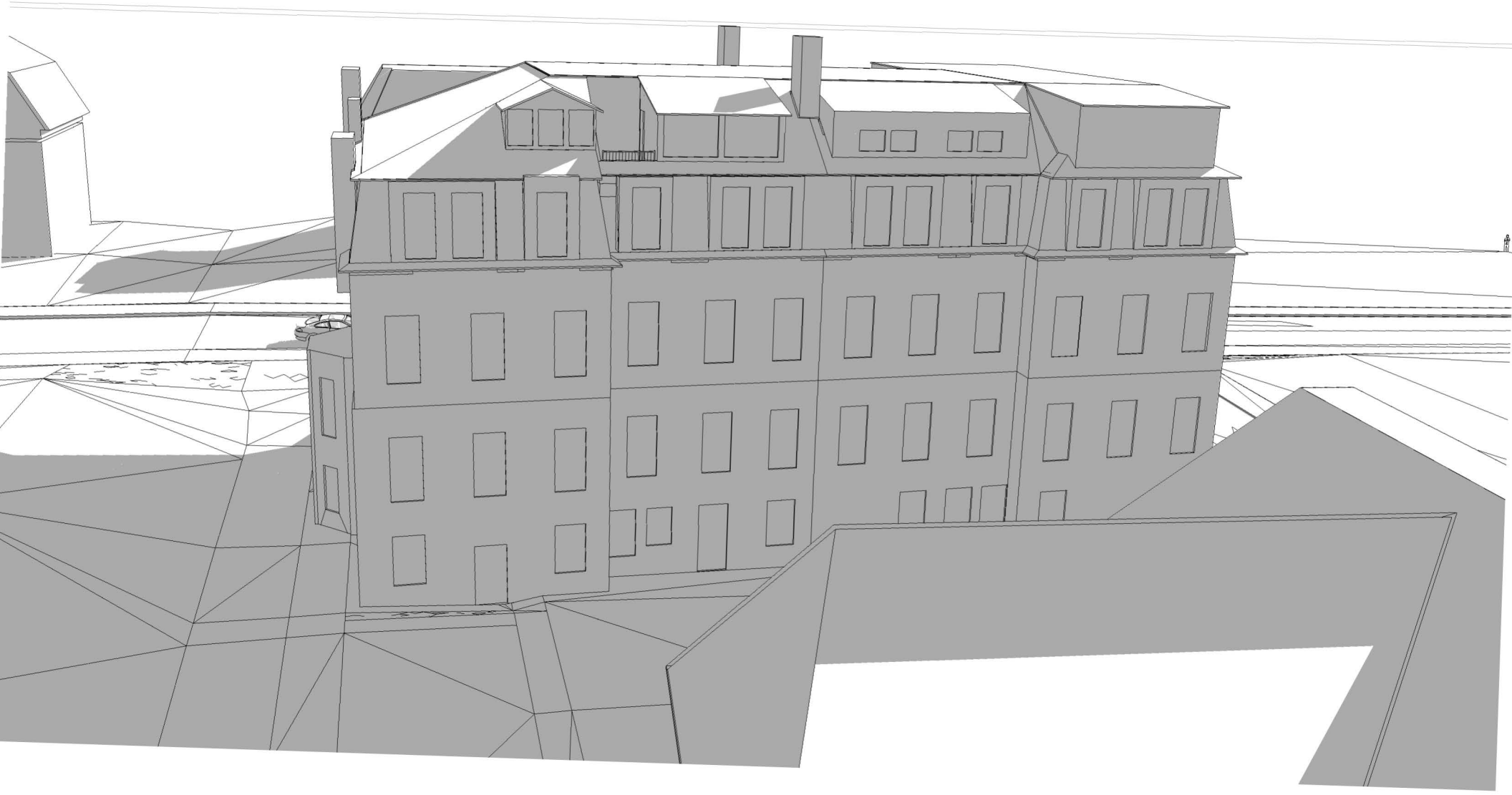

65 Sparks rear view, June 21, 9:00am

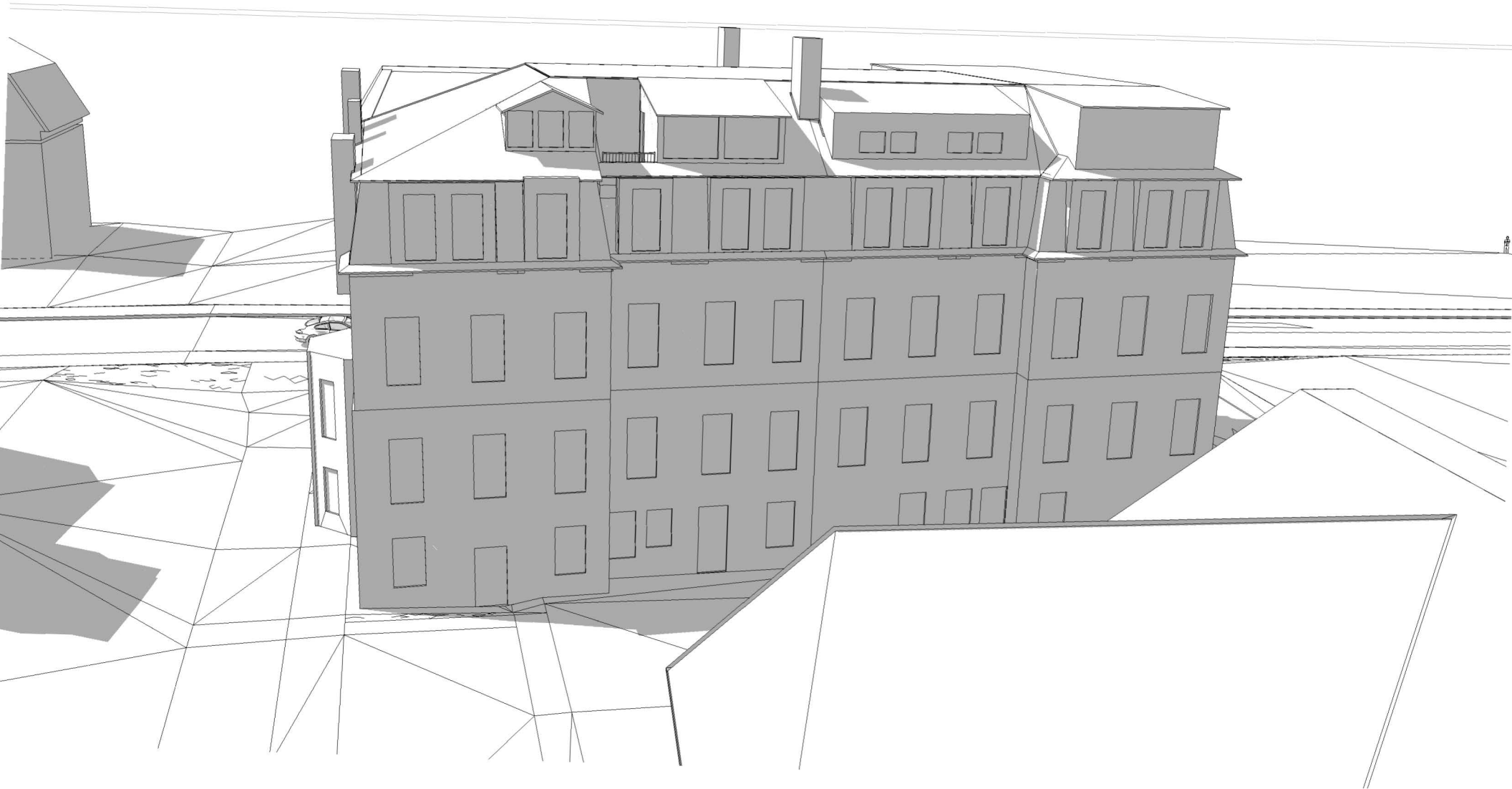

65 Sparks rear view, June 21, 12:00pm

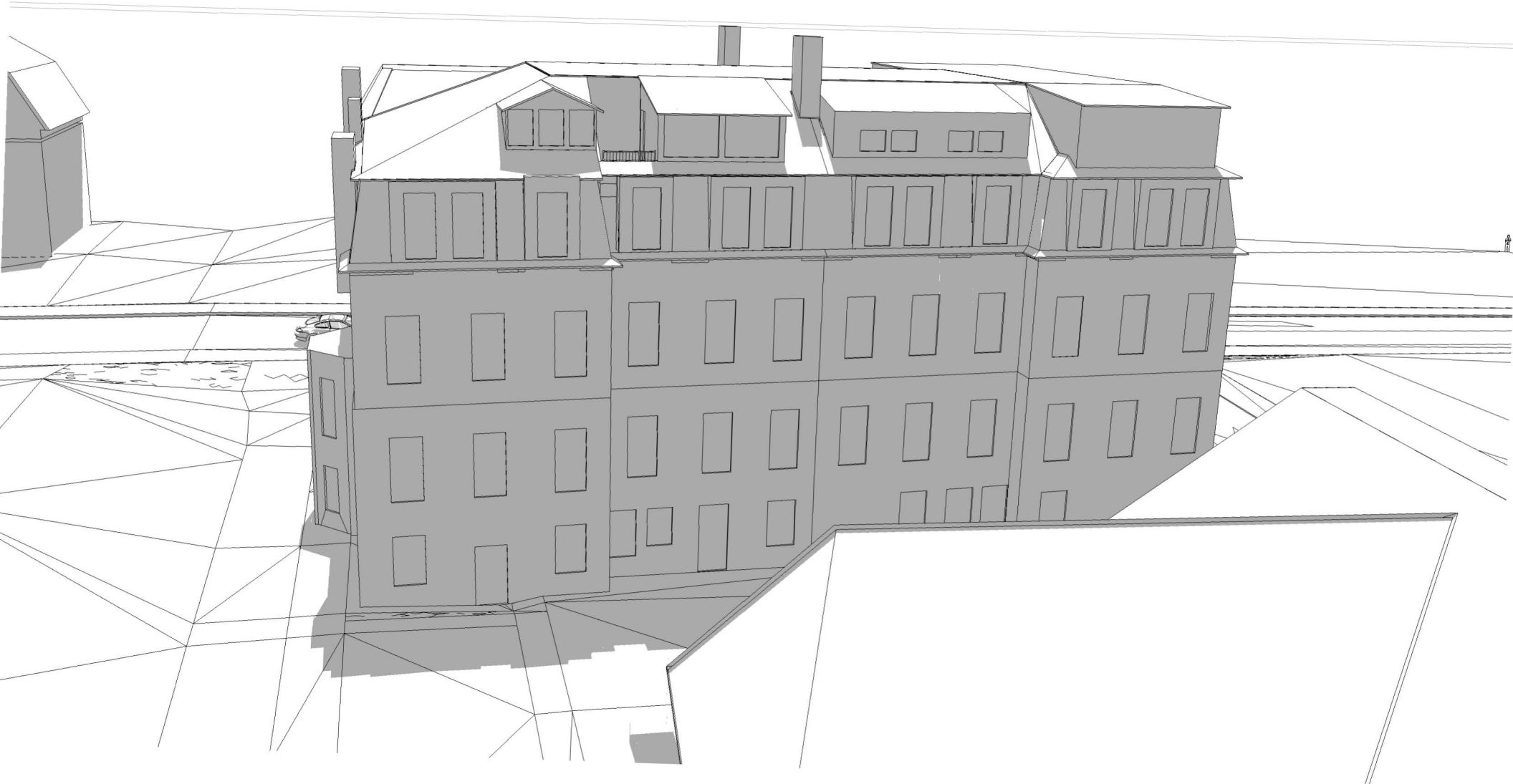

65 Sparks rear view, June 21, 3:00pm



65 Sparks rear view, September 21, 9:00am

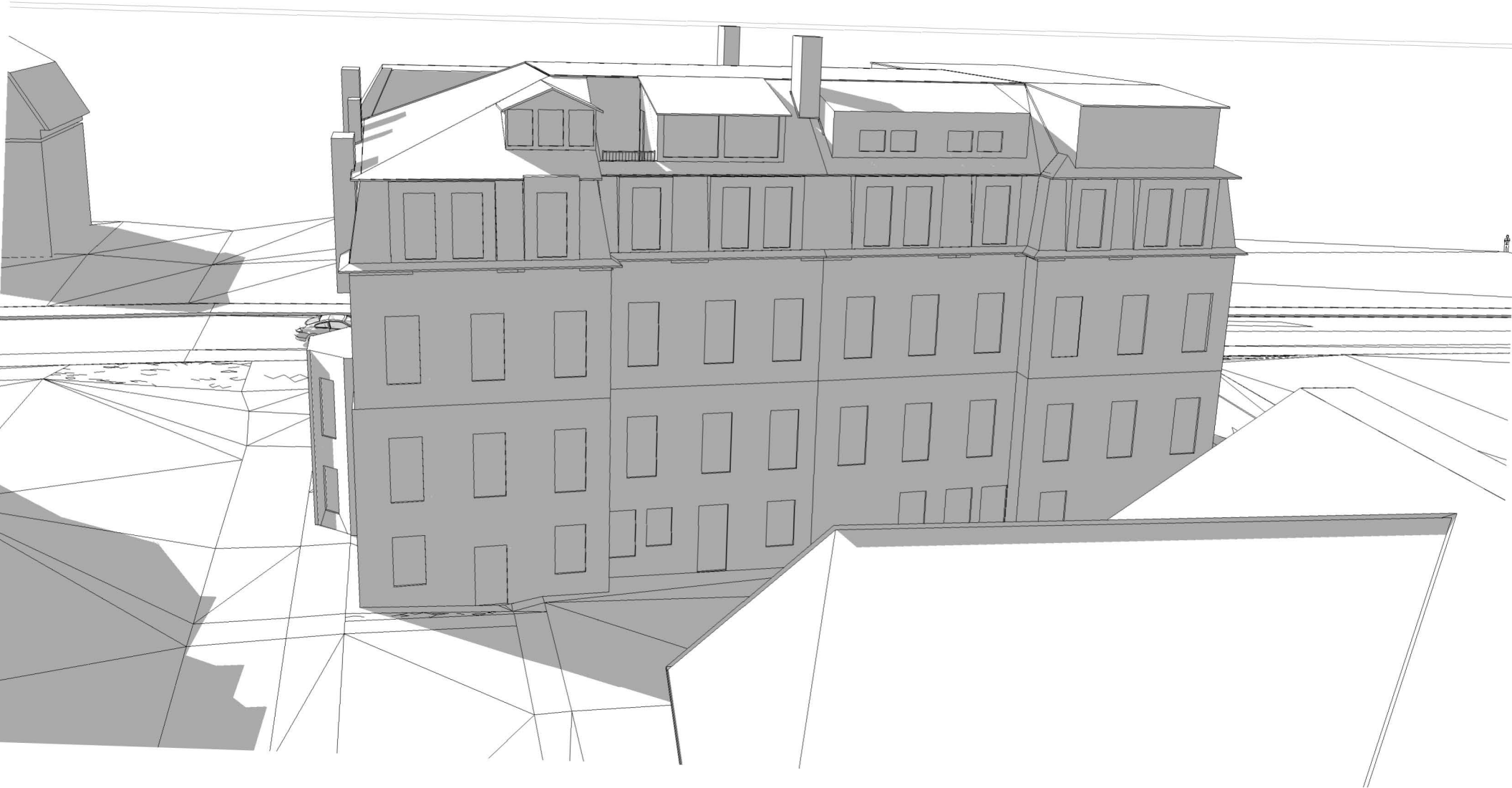

65 Sparks rear view, September 21, 12:00pm

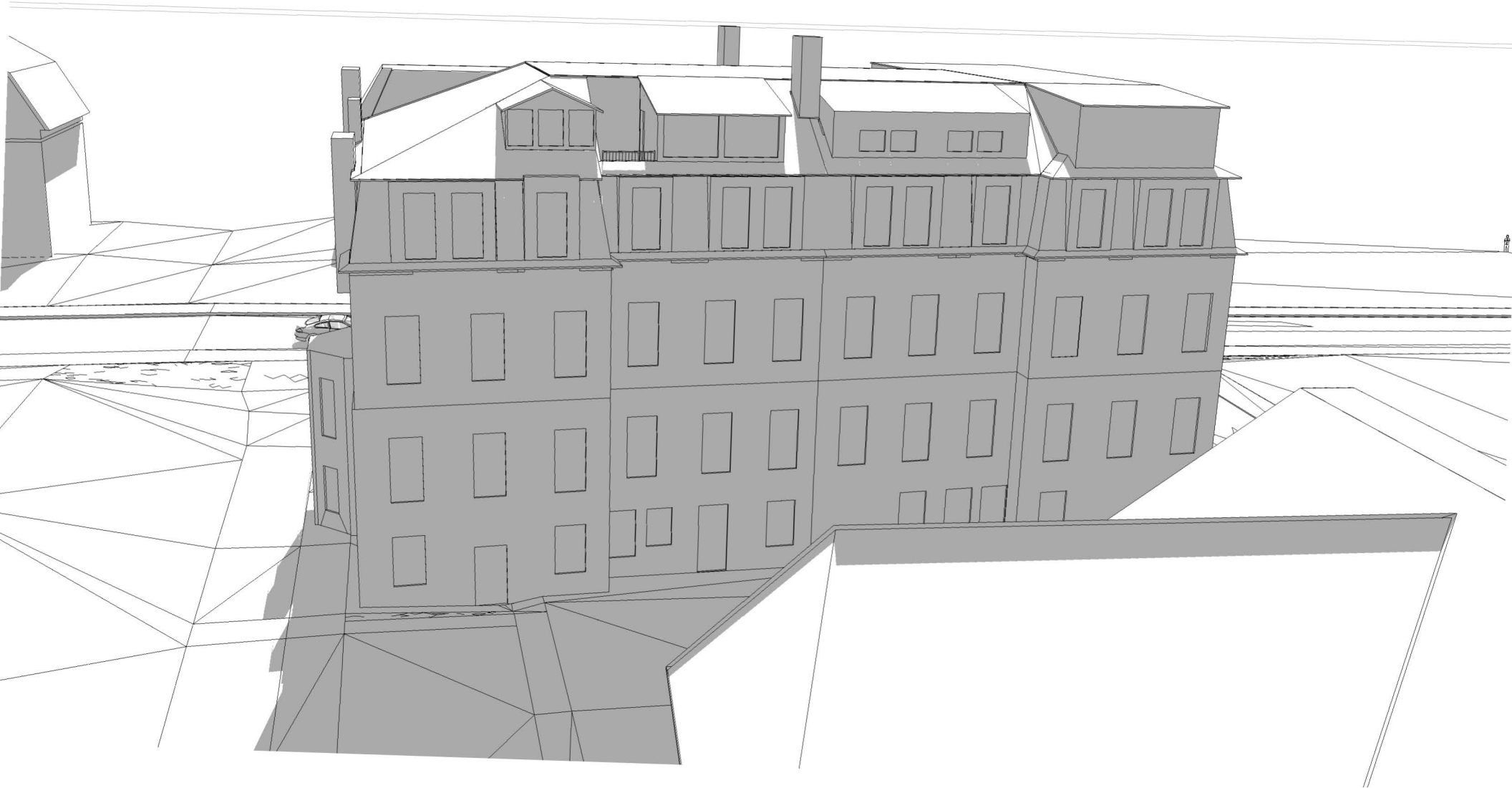

65 Sparks rear view, September 21, 3:00pm

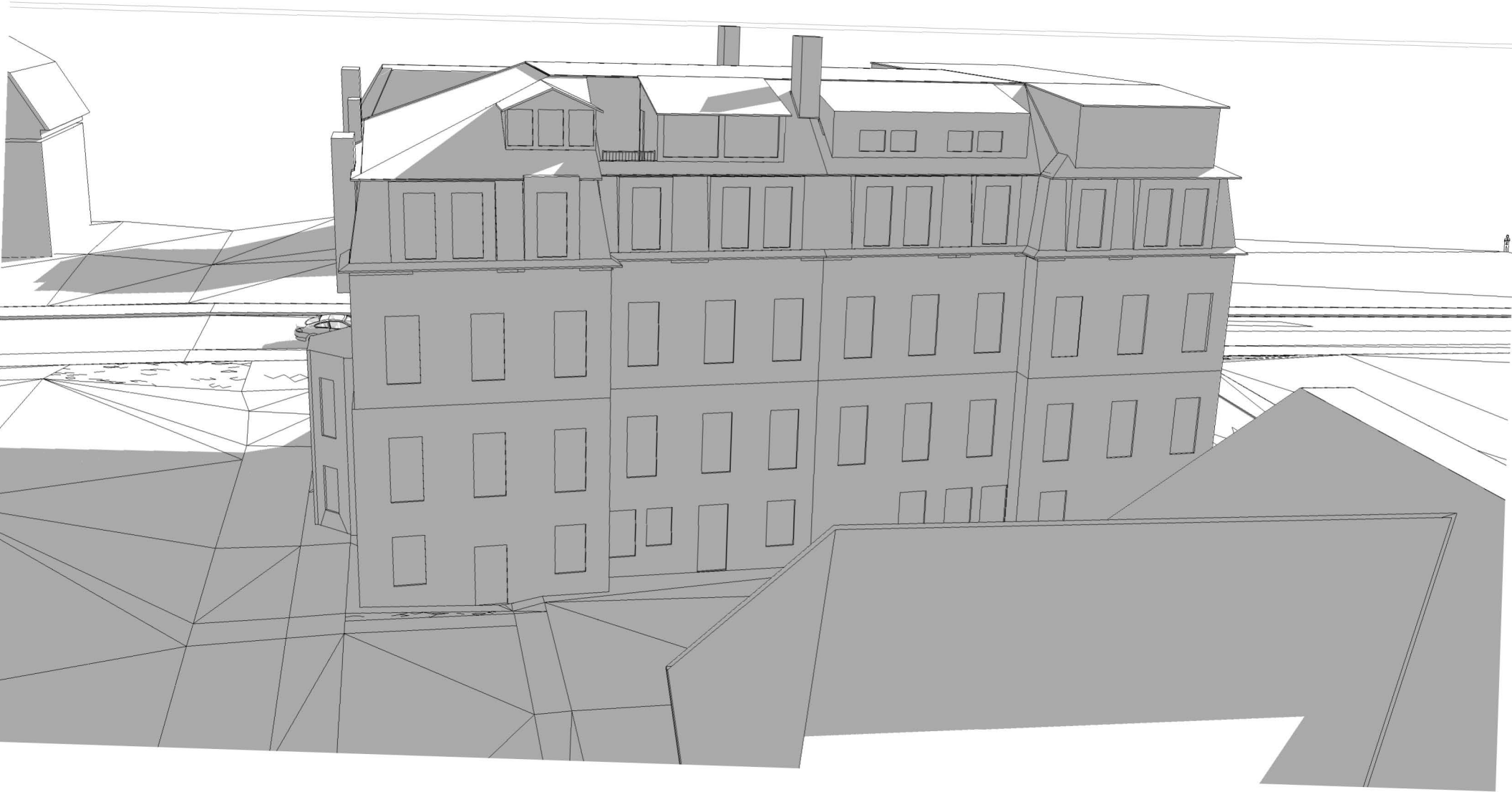

65 Sparks rear view, December 21, 9:00am

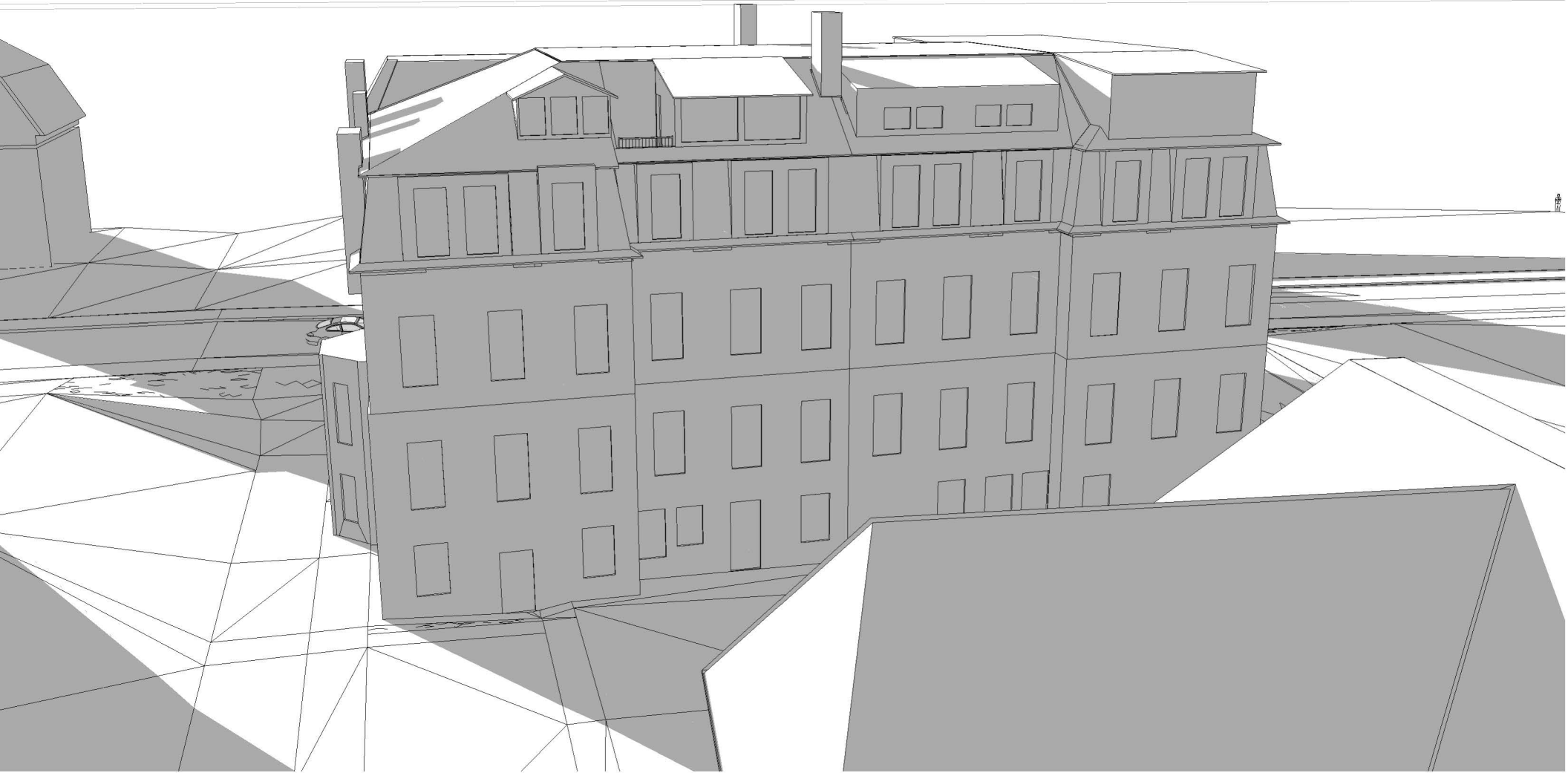

65 Sparks rear view, December 21, 12:00pm

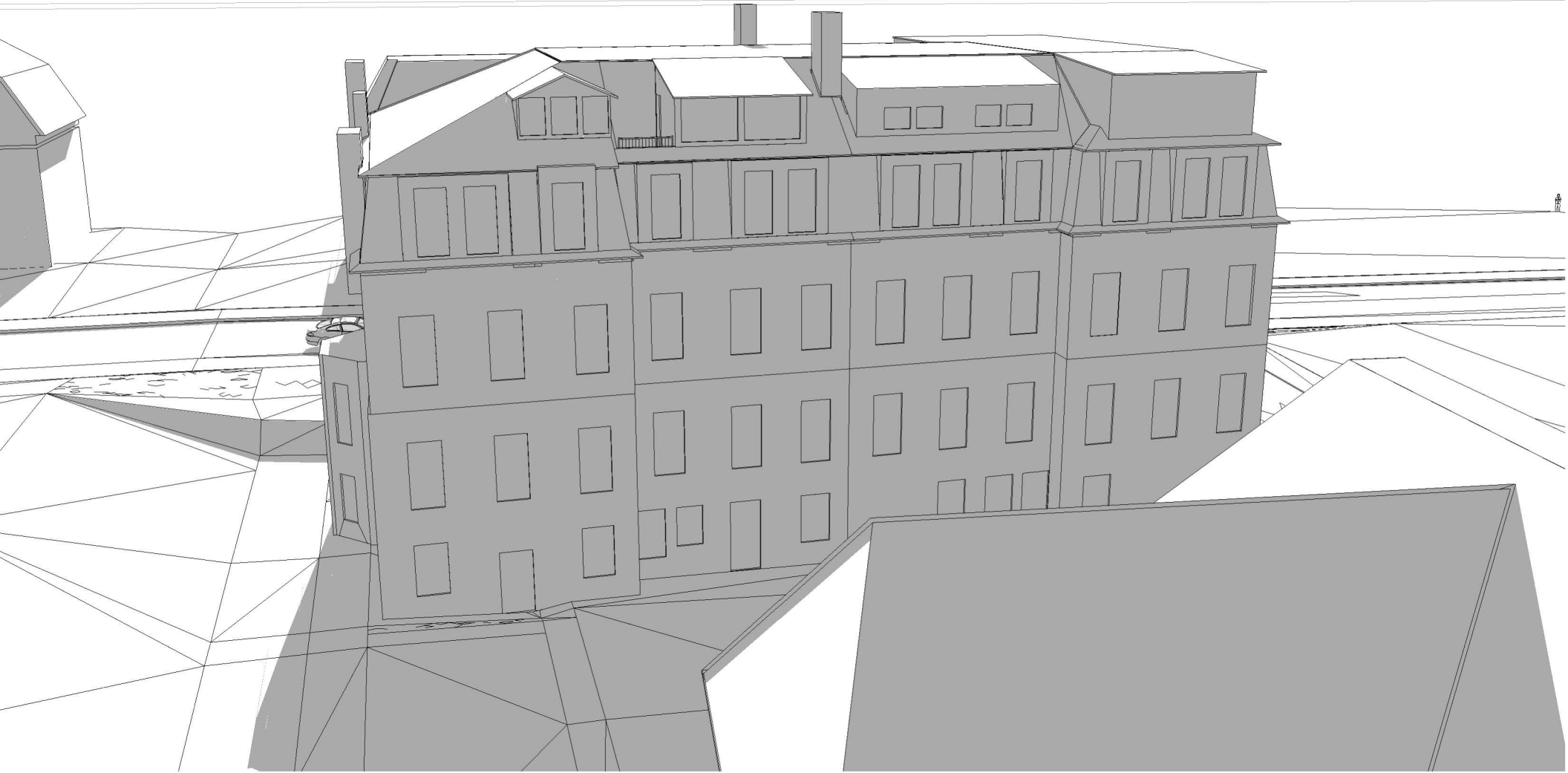

65 Sparks rear view, December 21, 3:00pm

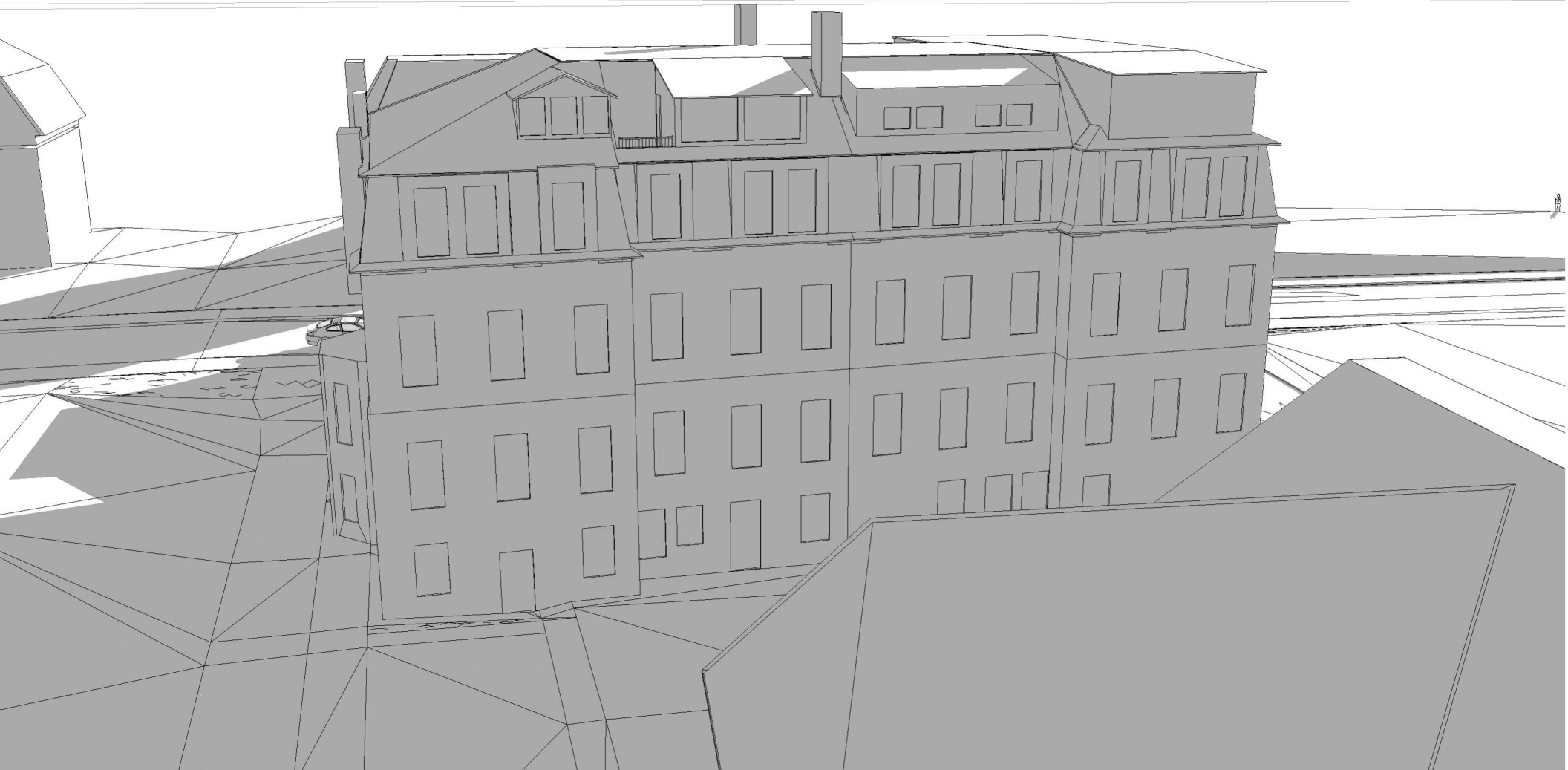

65 Sparks St. #4

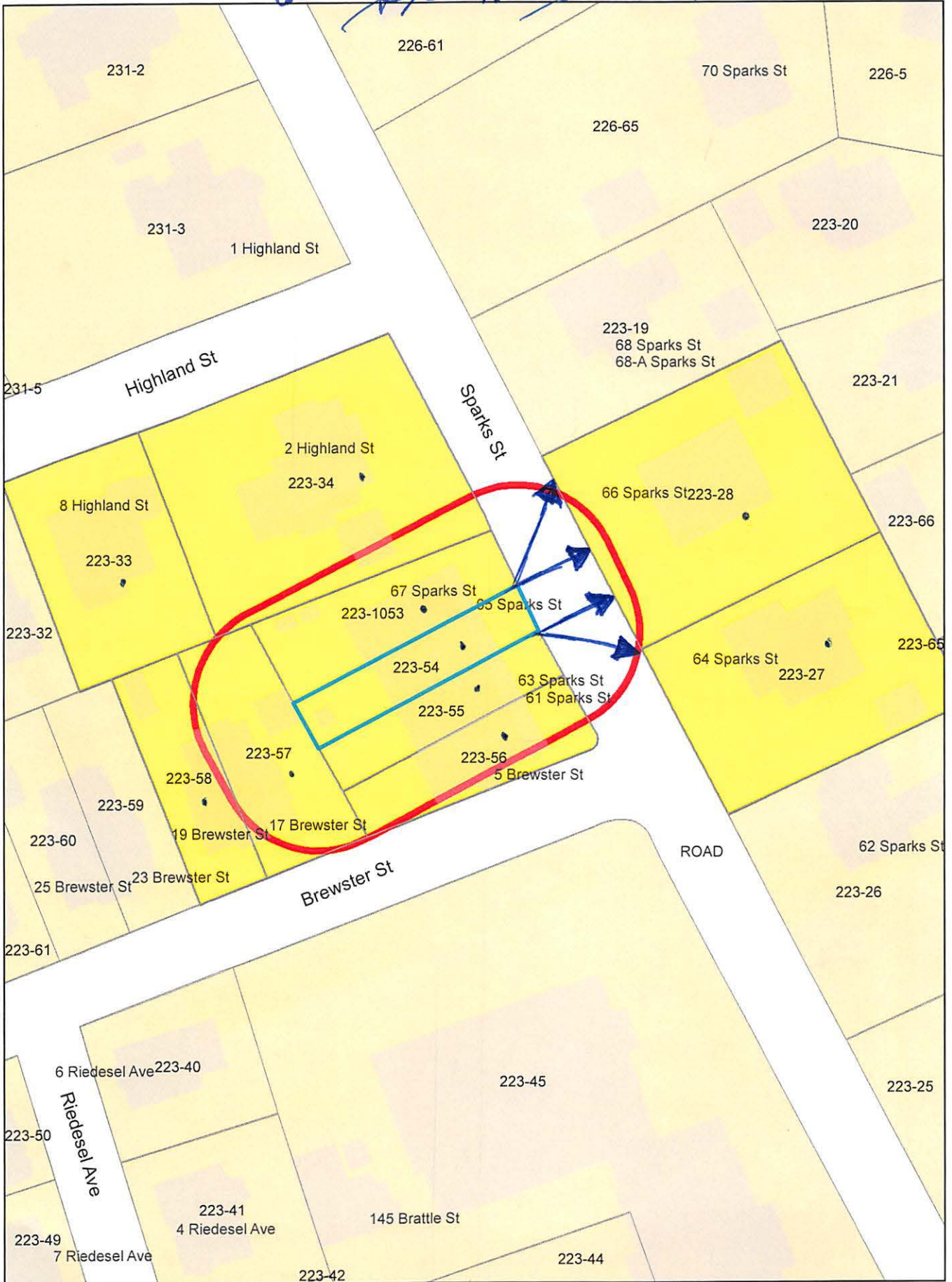

65 Sparks St. #4

Petitioner

223-27
BARRINGER, ELIZABETH PRATT & JOHN A. CLARK
64 SPARKS ST
CAMBRIDGE, MA 02138-2238

223-56
WELCH, THOMAS C. SVETLANA ANDREEVA
61 SPARKS ST UNIT #2
CAMBRIDGE, MA 02138

ADAM DASH, ESQ.
48 GROVE STREET – SUITE 304
SOMERVILLE, MA 02144

223-34
WOODS, AMY
2 HIGHLAND ST
CAMBRIDGE, MA 02138

223-55
WELCH, THOMAS C. & EDITH I. WELCH
TRS, THE EDITH I WELCH 2004 TRUST
63 SPARKS ST., #1
CAMBRIDGE, MA 02138

223-54
PATEL FEANIL & KIERSTEN KERBY-PATEL, LEE IVY
BLAKE SESSIONS, MICHAEL O'BRIEN,
BRIANNA McHORSE & DAVID LAIBSTAIN
65 SPARKS ST
CAMBRIDGE, MA 02138

223-56
EVANS, DAVID H.,
TRUSTEE THE DAVID H. EVANS REV TRUST
61 SPARKS ST., #4
CAMBRIDGE, MA 02138

223-56
YANG, NOAMI & DAMON KRUKOWSKI
61 SPARKS ST., #6
CAMBRIDGE, MA 02138

223-56
KRUKOWSKI, DAMON & NAOMI YANG
61 SPARKS ST., UNIT #1
CAMBRIDGE, MA 02138

223-55
STANG, DAVID D.
63 SPARKS ST., #2
CAMBRIDGE, MA 02138-2239

223-55
HILL, RICHARD C.
63 SPARKS ST., #4
CAMBRIDGE, MA 02138

223-56
FLANDERS, D. ANTHONY & CARLA J. PROCASKEY
61 SPARKS ST #3
CAMBRIDGE, MA 02138

223-58
CORRSIN, DAVID
19 BREWSTER ST
CAMBRIDGE, MA 02138

223-1053
TAGIURI, CONSUELO ROBERT TAGIURI
67 SPARKS ST
CAMBRIDGE, MA 02138

223-28
FISHER, JOSEPH,
TRUSTEE THE SPARKS TRUST
PO BOX 11270
JACKSON, WY 83002

223-55
DE LANTSHEERE CHARLES A
TRS TONI LEE DE LANTSHEERE TRS
63 SPARKS ST UNIT 3
CAMBRIDGE, MA 02138

223-33
BRETJ, JOHN P & JENNIFER K BRETJ
8 HIGHLAND ST
CAMBRIDGE, MA 02138

223-57
DAKOS, KRISTINA,
TR. THE KIRSTINA DAKOS 2104 REV TR.
17 BREWSTER ST
CAMBRIDGE, MA 02142

Naomi Yang
Damon Krukowski
61 Sparks Street, Apt 1
Cambridge, MA 02138
tel. 617-492-1934

Jan 27, 2023

To the Cambridge Board of Zoning Appeal:

We have lived in 61 Sparks Street since 1995 and we would like to express our full support for the proposed dormer addition and terrace at 65 Sparks Unit 4 (Case no. BZA-206407). It is in scale with the original building, sensitively done, and a welcome addition to the streetscape.

Sincerely,

Naomi Yang
Damon Krukowski