

Nicole Murati Ferrer
Chairperson

Stephen Lenkauskas
City Electrician

Terrence James Shea
Superintendent of Streets

CAMBRIDGE LICENSE COMMISSION

831 Massachusetts Avenue, First Floor, Cambridge, Massachusetts 02139

POLE AND CONDUIT COMMISSION

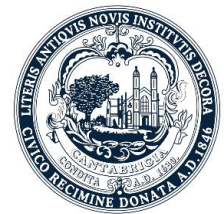

City of Cambridge

Elizabeth Y. Lint
Executive Director

POLE AND CONDUIT COMMISSION AMENDED MEETING AGENDA

Thursday, October 31, 2019 at 10:00 A.M.

Michael J. Lombardi Building, 831 Massachusetts Avenue
Carmelia M. Vicente Conference Room – Basement Level
Cambridge, Massachusetts

Administrative Matters

The following are the matters the Chair reasonably believes will be discussed and deliberated as of 10:00 a.m. with no public testimony.

1. **Revised (10/29/19)** City of Cambridge Pole and Conduit Commission's Policy Regarding Small Cell Wireless Installations on Public Ways, attachments thereto. Also includes a discussion of the License Agreement with the City of Cambridge. See Attached.
2. **Meeting Minutes** for September 19, 2019 and October 17, 2019.

Public Testimony Matters

The following are the matters the Chair reasonably believes will be discussed and deliberated, and for which applicant and public testimony will be accepted.

3. **Continuation from September 19, 2019, to figure out whether Nstar/Eversource is also going underground. (55617) Comcast, 426 E. First Street, Boston, MA 02127**, for the following: **90 Jackson Street** - From Pole #394/15 on **Jackson Street**, trench westerly 51'+/- in the public way. Installing 1-2" PVC conduit to the property line of **90 Jackson Street**. This will include the removal and replacement of 1 sidewalk panel.
4. **New Petition (58608) Comcast, 426 E. First Street, Boston, MA 02127**, for the following: **15 Lambert Street** - From newly place Pole #3 on **Lambert Street**, trench westerly +/- 28' installing 1-4" PVC conduit to the property line of **15 Lambert Street**.
5. **New Petition (58607) Comcast, 426 E. First Street, Boston, MA 02127**, for the following: **50 Rogers Street** - Place one new manhole over existing Comcast conduit. From new MH, trench southerly +/- 40' to the PP line of **50 Rogers Street**. Installing 1-4" PVC conduit.
6. **New Petition (58610) Comcast, 426 E. First Street, Boston, MA 02127**, for the following: **400 Main Street** - Place new Comcast manhole over existing conduit on **Carlton Street** to access conduit. From newly placed MH, trench westerly +/-29' installing 1-4" PVC conduit to the property line of **400 Main Street**. This will include the removal and replacement of one sidewalk panel.

7. **New Petition (58611) Comcast, 426 E. First Street, Boston, MA 02127**, for the following: **54 Market Street** - From pole 466/23, trench southerly +/-31 to the property line of **54 Market Street**. Installing 1-4" PVC conduit. This will include the removal and replacement of one sidewalk panel.
8. **New Petition (58105) Crown Castle NG East LLC, 1800 West Park Drive, Floor 2, Westborough, MA 01581**, for the following: **231 Third Street** - Trench and install (1) 4" conduit 12' +/- northwesterly in the sidewalk from utility Pole #667/35-5 to existing Crown Castle manhole. This will require the removal and replacement of 1 sidewalk panel.
9. **New Petition (58103) Crown Castle NG East LLC, 1800 West Park Drive, Floor 2, Westborough, MA 01581**, for the following: **Charles Street (from Sciarappa Street to Lopez Avenue)** - To install 619' +/- of fiber optic cable from Utility Pole #130/23a on **Charles Street** at **Sciarappa Street** easterly to Utility Pole #130/15. The purpose of the install is to provide service to the building at **58 Charles Street**.
10. **Continuation from September 20, 2018. Tolling agreement made. (57484) Crown Castle NG East LLC, 1800 West Park Drive, Floor 2, Westborough, MA 01581**, for the following: **69 Dunster Street** – This Eligible Facilities Request involves an effort to collocate Transmission Equipment at an existing Base Station within a public right of way **69 Dunster Street**. Pursuant to this Eligible Facilities Request Crown Castle proposes to replace the existing shroud with a new 70"H x 20"W x 18"D shroud, and the existing 48" x 8.16" Ø antenna with a new 48" x 18" Ø antenna.
11. **Continuation from May 16, 2019, to review attachment size. Tolling agreement made. (VP 45834) Crown Castle NG East LLC, 1800 West Park Drive, Floor 2, Westborough, MA 01581**, for the following: **Spring Street and Second Street** - Proposing to attach small cell site equipment to existing 35'5" wood utility pole (Pole #16) on the NE corner of **Spring Street and Second Street** (nearest address **9 Spring Street**). Fiber optic cable will feed aerial via overlashing to currently licensed poles on **Spring Street**.
12. **Continuation from May 16, 2019, to review attachment size. Tolling agreement signed. (VP 45830) Crown Castle NG East LLC, 1800 West Park Drive, Floor 2, Westborough, MA 01581**, for the following: **78 Spring Street** - Proposing to attach small cell site equipment to existing 29'1" utility pole(Pole #645/18) in front of **78 Spring Street**. Fiber will be fed aerial via overlashing to currently licensed poles on **Spring Street**.
13. **Continuation from May 16, 2019, to review attachment size. Tolling agreement signed. (VP 45816) Crown Castle NG East LLC, 1800 West Park Drive, Floor 2, Westborough, MA 01581**, for the following: **Gore Street and Lambert Street** - Proposing to attach small cell site equipment to existing 26'8" wood utility pole(Pole #30) at NW corner intersection of **Gore Street and Lambert Street**. Fiber optic cable will feed aerial via overlashing to currently licensed poles on **Gore Street**.

14. **Continuation from May 16, 2019, to review attachment size. Tolling agreement signed. (VP 45824)** Crown Castle NG East LLC, 1800 West Park Drive, Floor 2, Westborough, MA 01581, for the following: **Jay Street** - Proposing to attach small cell site equipment to existing 28'2" wood utility pole (Pole #22) in front of **71 Jay Street**. Fiber optic cable will feed aerial via overlashing to currently licensed poles on **Bay Street and Kinnard Street**. GOL to include 4 poles on **Kinnard Street** and 1 pole on **Jay Street**.

15. **Continuation from May 16, 2019, to review attachment size. Tolling agreement signed. (VP 45808)** Crown Castle NG East LLC, 1800 West Park Drive, Floor 2, Westborough, MA 01581, for the following: **Columbia Street** - Proposing to attach small cell site equipment to existing 33'8" wood utility pole(P.NT) in front of **266 Columbia Street**. Fiber optic cable will feed aerial via overlashing on two currently licensed poles on **Market Street**, north on **Columbia Street** on Pole #20, to cell site on Pole NT. GOL to include the two poles on **Columbia Street**.

16. **Continuation from September 19, 2019. Tolling agreement made. (53794)** Extenet Systems, Inc, 3030 Warrensville Road, Suite 240, Lisle, IL 60532, for the following: **69 First Street** - To install a small cell wireless facility on a replacement single pendant style light pole of approximately the same height, utilizing a steel "look-alike" pole painted to match the existing pole. The principal elements of the proposed facility are an omni-directional "whip" style antenna mounted at the top of the pole and three radios in a shroud also mounted on the pole. The proposed replacement pole fully accommodates the same type of light fixture, to be installed and made operational as part of this proposal. It is structurally stronger than the existing pole. See the plans accompanying this application for details. This proposal maintains the appearance of the existing streetscape and improves wireless capacity for residents, businesses and visitors.

17. **Continuation from September 19, 2019. Tolling agreement made. (53817)** Extenet Systems, Inc, 3030 Warrensville Road, Suite 240, Lisle, IL 60532, for the following: **75 Amherst Street** - To install a small cell wireless facility on a replacement single pendant style light pole of approximately the same height, utilizing a steel "look-alike" pole painted to match the existing pole. The principal elements of the proposed facility are an omni-directional "whip" style antenna mounted at the top of the pole and three radios in a shroud also mounted on the pole. The proposed replacement pole fully accommodates the same type of light fixture, to be installed and made operational as part of this proposal. It is structurally stronger than the existing pole. See the plans accompanying this application for details. This proposal maintains the appearance of the existing streetscape and improves wireless capacity for residents, businesses and visitors.

18. **Continuation from September 19, 2019. Tolling agreement made. (53880)** Extenet Systems, Inc, 3030 Warrensville Road, Suite 240, Lisle, IL 60532, for the following: **84 Massachusetts Avenue** - To install a small cell wireless facility on a replacement single pendant style light pole of approximately the same height, utilizing a steel "look-alike" pole painted to match the existing pole. The principal elements of the proposed facility are an omni-directional "whip" style antenna mounted at the top of the pole and three radios in a shroud also mounted on the pole. The proposed replacement pole

fully accommodates the same type of light fixture, to be installed and made operational as part of this proposal. It is structurally stronger than the existing pole. See the plans accompanying this application for details. This proposal maintains the appearance of the existing streetscape and improves wireless capacity for residents, businesses and visitors.

19. **Continuation from September 19, 2019. Tolling agreement made. (53891) Extenet Systems, Inc, 3030 Warrensville Road, Suite 240, Lisle, IL 60532**, for the following: **120 Broadway** - To install a small cell wireless facility on a replacement cobra style light pole of approximately the same height, utilizing a steel "look-alike" pole to match the existing steel pole. The principal elements of the proposed facility are an antenna housed in a shroud at the top of the pole and three radios in a shroud also mounted on the pole. The proposed replacement pole fully accommodates the same type of light fixture, to be installed and made operational as part of this proposal. It is structurally stronger than the existing pole. See the plans accompanying this application for details. This proposal maintains appearance of the existing streetscape and improves wireless capacity for residents, businesses and visitors.

20. **Continuation from September 19, 2019. Tolling agreement made. (53900) Extenet Systems, Inc, 3030 Warrensville Road, Suite 240, Lisle, IL 60532**, for the following: **8 Rockingham Street** - To install a small cell wireless facility on an existing wood utility pole. The principal elements of the proposed facility are an antenna housed in a shroud at the top of the pole and three radios in a shroud also mounted on the pole. See the plans accompanying this application for details. This proposal improves wireless capacity for residents, businesses and visitors.

21. **Continuation from September 19, 2019. Tolling agreement made. (55425) Extenet Systems, Inc, 3030 Warrensville Road, Suite 240, Lisle, IL 60532**, for the following: **60 Vassar Street** - To install a small cell wireless facility on a replacement "satellite" style light pole approximately 19' in height, utilizing a steel "look-alike" pole to match the existing pole. The principal elements of the proposed facility are an antenna housed in a 24" long shroud at the top of the pole and three radios in a shroud also mounted to the pole. The proposed replacement pole fully accommodates the same type of light fixture, to be installed and made operational as part of this proposal. It is structurally stronger than the existing pole. See the plans accompanying this application for details. This proposal maintains appearance of the existing streetscape and improves wireless capacity for residents, businesses and visitors.

22. **Continuation from September 19, 2019. Tolling agreement made. (55428) Extenet Systems, Inc, 3030 Warrensville Road, Suite 240, Lisle, IL 60532**, for the following: **42 Quincy Street** - To install a small cell wireless facility on a replacement cobra style light pole of approximately the same height, utilizing a steel "look alike" pole to match the existing steel pole. The principal elements of the proposed facility are an antenna housed in a 24" long shroud at the top of the pole and three radios in a shroud also mounted on the pole. The proposed replacement pole fully accommodates the same type of light fixture, to be installed and made operational as part of this proposal. It is structurally stronger than the existing pole. See the plans accompanying this application for

details. This proposal maintains appearance of the existing streetscape and improves wireless capacity for residents, businesses and visitors.

23. **Continuation from September 19, 2019. Tolling agreement made. (55466) Extenet Systems, Inc, 3030 Warrensville Road, Suite 240, Lisle, IL 60532**, for the following: **190 Harvard Street** - To install a small cell wireless facility on a replacement cobra style light pole of approximately the same height, utilizing a steel "look-alike" pole to match the existing steel pole. The principal elements of the proposed facility are an antenna housed in a 24" long shroud at the top of the pole and three radios in a shroud also mounted on the pole. The proposed replacement pole fully accommodates the same type of light fixture, to be installed and made operational as part of this proposal. It is structurally stronger than the existing pole. See the plans accompanying this application for details. This proposal maintains appearance of the existing streetscape and improves wireless capacity for residents, businesses and visitors.

24. **Continuation from September 19, 2019. Tolling agreement made. (55486) Extenet Systems, Inc, 3030 Warrensville Road, Suite 240, Lisle, IL 60532**, for the following: **266 Massachusetts Avenue-** To install a small cell wireless facility on a replacement single pendant style light pole of approximately the same height, utilizing a steel "look-alike" pole painted to match the existing pole. The principal elements of the proposed facility are an omni-directional "whip" style antenna mounted at the top of the pole and three radios in a shroud also mounted on the pole. The proposed replacement pole fully accommodates the same type of light fixture, to be installed and made operational as part of this proposal. It is structurally stronger than the existing pole. See the plans accompanying this application for details. This proposal maintains the appearance of the existing streetscape and improves wireless capacity for residents, businesses and visitors.

25. **Continuation from September 19, 2019. Tolling agreement made. (55489) Extenet Systems, Inc, 3030 Warrensville Road, Suite 240, Lisle, IL 60532**, for the following: **276 Windsor Street-** To install a small cell wireless facility on an existing wood utility pole. The principal elements of the proposed facility are an antenna housed in a 24" long shroud side-mounted on the pole and three radios in a shroud also mounted on the pole. See the plans accompanying this application for details. This proposal improves wireless capacity for residents, businesses and visitors.

26. **Continuation from September 19, 2019. Tolling agreement made. (55492) Extenet Systems, Inc, 3030 Warrensville Road, Suite 240, Lisle, IL 60532**, for the following: **247 Main Street** - To install a small cell wireless facility on a replacement single pendant style light pole of approximately the same height, utilizing a steel "look-alike" pole painted to match the existing pole. The principal elements of the proposed facility are a whip-style antenna mounted at the top of the pole and three radios also mounted on the pole. The proposed replacement pole fully accommodates the same type of light fixture, to be installed and made operational as part of this proposal. It is structurally stronger than the existing pole. See the plans accompanying this application for details. This

proposal maintains the appearance of the existing streetscape and improves wireless capacity for residents, businesses and visitors.

27. **Continuation from September 19, 2019. Tolling agreement made. (55510) Extenet Systems, Inc, 3030 Warrensville Road, Suite 240, Lisle, IL 60532,** for the following: **295 Broadway** - To install a small cell wireless facility on a replacement cobra style light pole of approximately the same height, utilizing a steel "look-alike" pole to match the existing steel pole. The principal elements of the proposed facility are an antenna housed in a 24" long shroud at the top of the pole and three radios in a shroud also mounted on the pole. The proposed replacement pole fully accommodates the same type of light fixture, to be installed and made operational as part of this proposal. It is structurally stronger than the existing pole. See the plans accompanying this application for details. This proposal maintains appearance of the existing streetscape and improves wireless capacity for residents, businesses and visitors.

28. **Continuation from September 19, 2019. Tolling agreement made. (55515) Extenet Systems, Inc, 3030 Warrensville Road, Suite 240, Lisle, IL 60532,** for the following: **449 Cambridge Street** - To install a small cell wireless facility on a replacement single pendant style light pole of approximately the same height, utilizing a steel "look-alike" pole painted to match the existing pole. The principal elements of the proposed facility are a "whip" style antenna mounted at the top of the pole and three radios in a shroud also mounted on the pole. The proposed replacement pole fully accommodates the same type of light fixture, to be installed and made operational as part of this proposal. It is structurally stronger than the existing pole. See the plans accompanying this application for details. This proposal maintains the appearance of the existing streetscape and improves wireless capacity for residents, businesses and visitors.

29. **Continuation from September 19, 2019. Tolling agreement made. (55530) Extenet Systems, Inc, 3030 Warrensville Road, Suite 240, Lisle, IL 60532,** for the following: **784 Main Street** - To install a small cell wireless facility on a replacement cobra style light pole of approximately the same height, utilizing a steel "look-alike" pole to match the existing steel pole. The principal elements of the proposed facility are an antenna housed in a 24" long shroud at the top of the pole and three radios in a shroud also mounted on the pole. The proposed replacement pole fully accommodates the same type of light fixture, to be installed and made operational as part of this proposal. It is structurally stronger than the existing pole. See the plans accompanying this application for details. This proposal maintains the appearance of the existing streetscape and improves wireless capacity for residents, businesses and visitors.

30. **Continuation from September 19, 2019. Tolling agreement made. (55531) Extenet Systems, Inc, 3030 Warrensville Road, Suite 240, Lisle, IL 60532,** for the following: **918 Cambridge Street** - To install a small cell wireless facility on a replacement single pendant style light pole of approximately the same height, utilizing a steel "look-alike" pole painted to match the existing pole. The principal elements of the proposed facility are a "whip" style antenna mounted at the top of the pole and three radios in a shroud also mounted on the pole. The proposed replacement pole fully

accommodates the same type of light fixture, to be installed and made operational as part of this proposal. It is structurally stronger than the existing pole. See the plans accompanying this application for details. This proposal maintains the appearance of the existing streetscape and improves wireless capacity for residents, businesses and visitors.

31. **Continuation from September 19, 2019. Tolling agreement made. (55533) Extenet Systems, Inc, 3030 Warrensville Road, Suite 240, Lisle, IL 60532**, for the following: **61 Gore Street**- To install a small cell wireless facility on an existing wood utility pole. The principal elements of the proposed facility are an antenna housed in a 24" long shroud at the top of the pole and three radios in a shroud also mounted on the pole. See the plans accompanying this application for details. This proposal improves wireless capacity for residents, businesses and visitors.

32. **Continuation from September 19, 2019. Tolling agreement made. (54618) Extenet Systems, Inc, 3030 Warrensville Road, Suite 240, Lisle, IL 60532**, for the following: **50 Ames Street** - To install a small cell wireless facility on a replacement single pendant style light pole of approximately the same height, utilizing a steel "look alike" pole painted to match the existing pole. The principal elements of the proposed facility are an antenna housed in a 24" long shroud at the top of the pole and three radios in a shroud also mounted on the pole. The proposed replacement pole fully accommodates the same type of light fixture, to be installed and made operational as part of this proposal. It is structurally stronger than the existing pole. See the plans accompanying this application for details. This proposal maintains appearance of the existing streetscape and improves wireless capacity for residents, businesses and visitors.

33. **Continuation from September 19, 2019. Tolling agreement made. (54620) Extenet Systems, Inc, 3030 Warrensville Road, Suite 240, Lisle, IL 60532**, for the following: **124 Hampshire Street** - To install a small cell wireless facility on a replacement cobra style light pole of approximately the same height, utilizing a steel "look alike" pole painted to match the existing steel pole. The principal elements of the proposed facility are an antenna housed in a 24" long shroud at the top of the pole and three radios in a shroud also mounted on the pole. The proposed replacement pole fully accommodates the same type of light fixture, to be installed and made operational as part of this proposal. It is structurally stronger than the existing pole. See the plans accompanying this application for details. This proposal maintains appearance of the existing streetscape and improves wireless capacity for residents, businesses and visitors.

34. **Continuation from September 19, 2019. Tolling agreement made. (54621) Extenet Systems, Inc, 3030 Warrensville Road, Suite 240, Lisle, IL 60532**, for the following: **131 Otis Street** - To install a small cell wireless facility on a replacement cobra style light pole of approximately the same height, utilizing a steel "look alike" pole painted to match the existing steel pole. The principal elements of the proposed facility are an antenna housed in a 24" long shroud at the top of the pole and three radios in a shroud also mounted on the pole. The proposed replacement pole fully accommodates the same type of light fixture, to be installed and made operational as part of this proposal. It is structurally stronger than the existing pole. See the plans accompanying this application for

details. This proposal maintains appearance of the existing streetscape and improves wireless capacity for residents, businesses and visitors.

35. **Continuation from September 19, 2019. Tolling agreement made. (54622) Extenet Sytems, Inc, 3030 Warrensville Road, Suite 240, Lisle, IL 60532**, for the following: **137 Magazine Street** - To install a small cell wireless facility on a replacement cobra style light pole of approximately the same height, utilizing a steel “look alike” pole painted to match the existing steel pole. The principal elements of the proposed facility are an antenna housed in a 24” long shroud at the top of the pole and three radios in a shroud also mounted on the pole. The proposed replacement pole fully accommodates the same type of light fixture, to be installed and made operational as part of this proposal. It is structurally stronger than the existing pole. See the plans accompanying this application for details. This proposal maintains appearance of the existing streetscape and improves wireless capacity for residents, businesses and visitors.

36. **Continuation from September 19, 2019. Tolling agreement made. (54623) Extenet Systems, Inc, 3030 Warrensville Road, Suite 240, Lisle, IL 60532**, for the following: **166 Prospect Street** - To install a small cell wireless facility on a replacement cobra style light pole of approximately the same height, utilizing a steel “look alike” pole painted to match the existing steel pole. The principal elements of the proposed facility are an antenna housed in a 24” long shroud at the top of the pole and three radios in a shroud also mounted on the pole. The proposed replacement pole fully accommodates the same type of light fixture, to be installed and made operational as part of this proposal. It is structurally stronger than the existing pole. See the plans accompanying this application for details. This proposal maintains appearance of the existing streetscape and improves wireless capacity for residents, businesses and visitors.

37. **Continuation from September 19, 2019, to determine size of service and whether there is a need. (VP 55440) Nstar Electric Company, 10 Linwood Street, Somerville, MA 02143**, for the following: **82 Mt. Auburn Street** - Westerly from MHC81, at the intersection of **Dunster Street**, install approximately 38 feet conduit.

38. **Continuation from September 19, 2019, to look for new corridor and meeting with DPW. (VP 55439) Nstar Electric Company, 10 Linwood Street, Somerville, MA 02143**, for the following: **85 First Street - Hurley Street**, at and westerly from new manhole MHC30850, approximately 220 feet west of **First Street**, install approximately 120 feet conduit

Hurley Street, at and easterly from new manhole MNH30850, approximately 220 feet west of **Hurley Street**, install approximately 125 feet conduit.

39. **Continuation from September 19, 2019, to determine what will happen to small cell on Pole #23 or whether going to different pole. (VP 54496) Nstar Electric Company, 10 Linwood Street,**

Somerville, MA 02143, for the following: **40-54 Market Street** - Southwesterly from Pole 466/23, approximately 115 feet northwest of **Union Street**, install approximately 39 feet conduit.

40. **New Petition (VP 58697) Nstar Electric Company, 10 Linwood Street, Somerville, MA 02143**, for the following: **90 Jackson Street** - Southwesterly from Pole 394/15 approximately 120 feet north of **Dudley Street**, install approximately 53 feet conduit.

41. **New Petition (VP 58698) Nstar Electric Company, 10 Linwood Street, Somerville, MA 02143**, for the following: **750 Main Street** - Northwesterly from MHC814, approximately 180 feet west of **Osborn Street**, install approximately 13 feet conduit.

42. **New Petition (VP 58772) Nstar Electric Company, 10 Linwood Street, Somerville, MA 02143**, for the following: **55-59-63 Union Street** - Northwesterly from Pole 680/16, approximately 95 feet south from **Lincoln Street**, install approximately 8 feet conduit.

43. **New Petition (VP 58709) Nstar Electric Company, 10 Linwood Street, Somerville, MA 02143**, for the following: **13 Vincent Street** - Northeasterly from Pole 693/3, approximately 171 feet southeast from **Walden Street**, install approximately 4 feet conduit.

44. **New Petition (VP 58706) Nstar Electric Company, 10 Linwood Street, Somerville, MA 02143**, for the following: **JFK Street** - Southwesterly from MHC2080, approximately 123 feet southwest of **Brattle Street**, install approximately 69 feet conduit.

45. **New Petition (VP 58705) Nstar Electric Company, 10 Linwood Street, Somerville, MA 02143**, for the following: **North Point Boulevard** - Southeasterly from MHC2958, at the intersection of **Museum Way**, install approximately 390 feet—conduit.

Education Street - Northwesterly at the intersection of **North Point Boulevard**, install approximately 24 feet—conduit.

46. **New Petition (VP 58700) Nstar Electric Company, 10 Linwood Street, Somerville, MA 02143**, for the following: **1465 Massachusetts Avenue** - Southerly from MHC187, at the intersection of **Garden Street**, install approximately 142 feet conduit.

PLEASE NOTE THAT THE ORDER IN WHICH MATTERS ARE LISTED DOES NOT GUARANTEE IT IS THE ORDER WHICH THEY WILL BE CALLED. AS SUCH, PLEASE BE SURE TO ARRIVE AT THE NOTICED TIME OF 10:00 AM.

A handwritten signature in blue ink that reads "Elizabeth Lint". The signature is written in a cursive style.

Elizabeth Lint, Executive Director

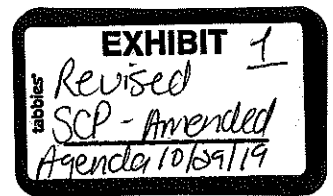

**City of Cambridge Pole and Conduit Commission's Policy
Regarding Small Cell Wireless Installations on Public Ways
("Small Cell Policy")**

The City of Cambridge ("City") Pole and Conduit Commission ("Commission") hereby adopts this policy ("Policy") regarding Applications ("Application") relating to installations and upgrades which substantially change or defeat the existing concealment elements of small wireless facilities ("Small Wireless Facilities"), including communications equipment and related infrastructure on or within public rights of way in the City ("Installations or Installation"). Small Wireless Facilities shall include any facilities as defined in footnote 9 of the Declaratory Ruling and Third Report and Order, dated September 26, 2018 by the Federal Communications Commission.

I. Application Process

- A. Applicants ("Applicants") shall submit Applications to the Commission accompanied by an Application fee of \$500 per Application, payable to the "City of Cambridge." The \$500 fee will cover up to 5 Installations submitted with each Application. Each Application for more than 5 Installations is subject to a separate fee of \$100 per Installation after the first 5 Installations. Additionally, a \$270 fee (which shall be an "Annual Recurring Fee") for each Installation shall be required to be submitted within five business days of any grant of said Application. If the Application relates to a request for installation of a new non-City owned pole or other structure, a one-time \$1,000.00 fee shall be required for each such new pole or other structure in addition to said Annual Recurring Fee. The amounts due under this section may be revised by the Commission from time to time, consistent with applicable law. In the event the City's costs in reviewing any Application exceed the amounts prescribed in this section, Applicants shall be responsible for those costs.
- B. The Application process shall, in addition to the requirements described herein, follow the Siting Policy of the Commission ("Siting Policy").
- C. Applicants shall provide notice by first class mail to all other wireless providers, within the Applicant's knowledge after reasonable inquiry to the Commission staff, who use or may request use of the public right of way for communications services within five hundred feet (500') of the proposed location(s) ("Other Providers"). Such notice shall inform recipients of the Applicant's application, including specifying the pole(s) or other structures to be utilized, and any excavation(s) of the public way contemplated by the work. Proof of mailing of such notice shall be provided within three (3) business days of application submission, and may be provided by submission of an affidavit.
- D. Commission staff shall notify the Applicant, in writing, within 10 days, if the Application is incomplete, specifying the information needed and the relevant policy or ordinance provision or requirement. If an Applicant supplements its Application, the date of such supplementation shall be considered the new application date for purposes of any required time requirements. With respect to the supplementation, the Commission staff shall notify the Applicant, in writing, within 10 days of the supplementation if the Application is still not complete, specifying the information

needed and the relevant policy or ordinance provision or requirement. After such written notification, any required time periods shall be tolled until such time that the Applicant provides the required information. In the event an application remains incomplete forty-five (45) days after any notice that the application is incomplete and the Applicant has not responded, such application shall be deemed denied without prejudice, and will need to be resubmitted in full, including payment of fees accompanying a new application. Denial for incompleteness shall not entitle Applicant to refund of any fees paid. Commission staff's determination of the completeness of an Application is administrative and not substantive in nature; it does not imply or concede that the Commission will not find the Application defective and/or that it will ultimately be approved by the Commission.

- E. Once the Commission staff has determined that an Application is complete, the Commission staff will schedule the Application to be heard at a public hearing of the Commission to consider the Application. The Applicant shall notify all Other Providers, as applicable, of the hearing date, and of any continued or rescheduled hearing date, within three days after such hearing date is scheduled. The Applicant shall, within three days after such hearing date is scheduled, notify to all owners of properties that share a common boundary with the area proposed, extending all the way to the owners of properties on either side of the area proposed in both directions for a distance of one hundred fifty feet, and to owners of property on the opposite side of the street of the area proposed, or, where the area proposed is adjacent to an intersection, all property owners in all directions of the public way for a distance of one hundred fifty feet as described in the previous sentence (hereinafter "Abutters"), by first class mail, of the scheduled hearing date, and of any continued or rescheduled hearing date. Proof of mailing of such notice shall be provided within three (3) business days of mailing, and may be made by submission of an affidavit. Failure to notify all Abutters and Other Providers, or said affidavit of proof of mailing, as applicable, may result in denial of the Application. Alternatively, Applicant may sign an extension agreement extending the time within which the Commission may respond to the Application by one week for every extra day that the Applicant needs to notify all Abutters and Other Providers, with a corresponding agreement to extend the hearing date accordingly. Notification of Abutters for purposes of this section may be made to a condominium association, where there are 20 or more units within such condominium association, but for condominiums of less than 20 units, each individual unit owner must be notified.
- F. Recipients of notice provided under subsection C, above, are strongly encouraged to consider collocation with the Applicant, and Applicant shall in good faith entertain proposals to cooperate in order to minimize the impact of deployments in the City. In particular, Applicants and Other Providers are strongly encouraged to utilize shared conduit or trenching in order to both minimize their individual costs, and in pursuit of mutually beneficial common trench policies to speed deployment and minimize harmful excavation in the City's streets and sidewalks. Applicant is required, throughout the review of any Application, to promptly notify the City of any request for cooperation received from any Other Provider, and if Applicant elects not to cooperate, it shall supplement its Application with an explanation as to why it is so electing.

- G. For any reason, the Commission and the Applicant may enter into a tolling agreement for the consideration of the Application at a future hearing before the Commission for any reason at any time.
- H. The Commission may grant, grant with conditions, or deny an Application. Applications may be approved if they comply with all applicable requirements, or if their approval is otherwise required consistent with applicable law. A denial may be based on criteria including but not limited to any of the following:
 - i) inadequate capacity of the pole or mounting structure;
 - ii) failure to meet applicable engineering standards;
 - iii) failure to meet the Commission's design standards;
 - iv) failure of the Applicant to comply with all applicable laws, rules, regulations or other requirements;
 - v) there are more convenient or favorable nearby locations such that the applicant may densify its network through such nearby locations which are more consistent with the City's preferred locations as otherwise described herein, or where there may be an opportunity for a collocation;
 - vii) false statements made in the Application or submitted therewith, or at the hearing before the Commission; and
 - viii) any other legally valid reason to deny such Application.
- I. Any approval granted to an Applicant shall be only for the specific Applicant and Application, including location of all proposed Installations.
- J. If the Commission denies the Application, such denial shall not be effective until the written decision is executed and issued to the Applicant by the Chair.
- K. Any tolling agreement reached by the Applicant and the Commission must be memorialized in writing on the Commission's form entitled *Tolling Agreement Relative to Small Cell Installation Petition* ("Tolling Agreement") attached hereto as Exhibit I(K), executed by the Applicant and submitted to the Commission within three (3) business days of the agreement being made. Failure of the Applicant to provide an executed Tolling Agreement within three (3) business days of an Applicant's agreement to do so shall constitute a binding agreement with the Commission that the Applicant's is withdrawing the subject Application without prejudice to re-filing, and such Application shall be considered withdrawn upon expiration of such third (3rd) business day without further action of the parties.

II. Content of Applications

Applications shall include the following information, in digital form, in addition to information related to notification and collocation required by the preceding Section:

- A. Applicant's name, address, telephone number and email address.
- B. Names, addresses, telephone numbers, and email addresses of anyone acting on behalf of the Applicant with respect to the Application. If any person other than the Applicant shall utilize the proposed Installation to provide any service (such as a wireless carrier utilizing a neutral host site constructed and operated by Applicant), the Application shall include the same contact information for that person, as well as

- documentation demonstrating a binding commitment from such person(s) that the proposed Installation will be used to provide service within six (6) months of construction.
- C. A copy of a License Agreement issued by the City, executed by the Applicant. Full execution by the City shall occur at the time of permit issuance, in the event of approval. For Installations proposed on non-City owned structures, Applicant shall provide a license agreement or other documentation showing approval and authority for attachment to such structure from the owner of such structure, as well as sign a License Agreement for utilizing the public way, executed by the Applicant. Full execution by the City shall occur at the time of permit issuance, in the event of approval. Further, any other required executed agreements, forms or licenses may be required as determined and provided by the Commission.
- D. Detailed drawings and descriptions of the equipment to be installed, signed by a Massachusetts licensed engineer, whether mounted on poles or on the ground, or otherwise, including:
- i. Type of equipment;
 - ii. Specifications of equipment (including but not limited to dimensions and weight);
 - iii. Equipment mount type and material;
 - iv. Power and/or communication source and/or sources for equipment, including route of any necessary fiber, wires, cables, and conduit, distance and direction from the power and/or communication or conduit sources, and maps of any proposed excavation, and extent of excavation needed;
 - v. Rendering and elevation of equipment; and
 - vi. Photo simulations, from four different angles, showing the pole and streetscape before the installation, as well as after installation.
- E. A detailed map in a digital format acceptable to the Commission with locations of the poles or other property on which equipment is to be located, including specific pole type, and pole identification number, if applicable.
- F. Insurance certificates with the following minimum coverages: General liability insurance in an amount not less than \$1,000,000 per occurrence and \$2,000,000 in the aggregate, worker's compensation insurance not less than the amount of \$100,000 per accident and \$500,000 per illness or the statutorily required amount, whichever is greater, and umbrella insurance in an amount not less than \$5,000,000. The City must be an additionally named insured, and such policies shall indicate that the insurance company shall provide thirty (30) business days' prior written notice to the City of lapse or cancellation. All insurance carriers shall carry an A.M. Best rating of "A-" or better. Such insurance shall provide for the waiver by the insurance carrier of any subrogation rights against City, its agents, servants and employees.
- G. Any and all permits and approvals, including but not limited to any permits from the City of Cambridge Department of Public Works, the Police Department, the Cambridge Historical Commission, the Cambridge Community Development Department, the Traffic, Parking and Transportation Department or any other City department or federal or state agency required for the proposed Installation, shall be applied for on the same day as the submission of the Application, or promptly thereafter, but not before the submission of the Application, and such that any such

permits and approvals are valid at the time of any grant of location hereunder. Applicant shall reapply for any approvals or permits that have expired prior to any grant of location being approved under this policy.

- H. A description as to why the desired location is superior to other similar locations, including, but not limited to:
 - i. Aspects showing that the Installation will not incommode the public way;
 - ii. Visual aspects; and
 - iii. Proximity to residential buildings and descriptions of efforts to prevent any blocking of views from windows.
- I. A description of efforts to collocate the Installation(s) on existing structures, poles, or towers which currently exist or are under construction pursuant to the Siting Policy. A good faith effort to collocate is required and written evidence of such efforts must be submitted with the Application, all pursuant to the Siting Policy. Further, this Policy encourages multiple wireless carriers to collocate their wireless communications equipment and related infrastructure on an existing pole or support structure. In the event an Application is submitted for an Installation which does not contemplate collocation at the time of the Application or in the future, that Application shall include a detailed technical explanation as to why collocation is technically impracticable.
- J. An affidavit(s) from Massachusetts-licensed licensed engineer(s) attesting:
 - i. The Applicant or the carrier intending to use the Installation is in good standing and currently licensed by the Federal Communications Commission;
 - ii. The proposed Installation complies with any regulations of the Federal Communications Commission;
 - iii. The proposed Installation(s) complies with the maximum safe distance from the antennae and equipment for prolonged and discrete human or animal exposure under the Federal Communications Commission regulations, including but not limited to, a description of the distances (in feet) considered safe and compliant with Federal Communications Regulations in terms of radiation emissions exposure limitations with respect to a human and/or animal from the proposed antennae for one year, one month, for one day, and for one hour, and a description of the circumstances, if any, under which a non-trespassing individual (i.e. an adjacent property owner) may come within those distances;
 - iv. That the pole or property will safely support the proposed equipment and proposed Installation(s);
 - v. That the Installation(s) shall comply with the City of Cambridge Noise Ordinance;
 - vi. That all other Installations by the Applicant or parent company which are no longer in use have been removed and the annual re-certification has been submitted for such Installations, and all fees and fines paid with regard to such Installations, and any City property, including the public way, has been restored to the condition existing prior to such Installation, in accordance with all City standards and at Applicant's expense;
 - vii. A detailed explanation of how the proposed Installations(s) will provide service in the City, including a description of services to be improved or

newly provided, and which shall include evidence of the current level of coverage in the area, how the desired Installation(s) will change the current level of coverage, and an explanation as to why the Applicant believes denial of the proposed Installation would constitute an effective prohibition of an entity's ability to provide wireless services; and

- viii. Any supporting documentation proving the foregoing, including but not limited to, a detailed map (in digital format acceptable to the Commission) showing the Applicant's existing and proposed Installation(s) within 500 feet of the Application site, and amount of cellular coverage in the area.

III. Annual Re-Certification and Affidavit

- A. Each year, no later than March 1, the Applicant shall submit an affidavit to the Commission which shall list, by location, all Installation(s) it owns within the City by location, including pole number, and shall certify the following: (1) each Installation that remains "in use;" (2) that such Installations remain covered by insurance; and/or (3) each such Installation that is no longer in use.
- B. The Applicant shall pay an annual re-certification fee of \$270 per Installation to the Commission. Any Installation which is no longer in use, abandoned or is no longer authorized to operate by law or other regulation, shall be considered in default and removed. Any of the City-owned equipment shall be returned to the City after all elements of the Installation have been removed at the discretion of the City, as provided in the License Agreement to be entered into with the City.

IV. Prohibitions

- A. No Installations will be permitted to be installed on double poles.
- B. No Installations will be permitted to be installed on poles which result in non-compliance with any applicable federal, state and/or local laws, rules and regulations.
- C. No Installations shall remain upon the City right of way or on City property which has not been certified as "in use" in the annual re-certification affidavit.
- D. No Installations will be permitted to be installed on any traffic signal pole or other related infrastructure or equipment.
- E. An Applicant may submit an Application inconsistent with the foregoing prohibitions, but only if accompanied by evidence sufficient to demonstrate that the otherwise prohibited Installation must be considered by the City in order to avoid a prohibition or effective prohibition on the provision of service, as defined by applicable federal law.

V. Design and Location Requirements for Installations

The purpose of the Design and Location Requirements for Installations is to preserve the character of Cambridge's neighborhoods and commercial corridors.

- A. Intent of the Design and Location Requirements for Installations.

- i. Minimizing visual as well as physical clutter to the maximum extent possible.
- ii. Maintaining public open spaces and parks clear of visual clutter of communication and signage elements.
- iii. Discouraging placement of Installations on decorative pedestrian municipal street lights.
- iv. Standardizing components of Installations, e.g., size, scale, color, location to be consistent with character of existing public infrastructure in the public right of way.
- v. Avoiding siting of Installations in front of designated historic structures, landmarks, parks or impacting view corridor to major natural, cultural, or historic resources.
- vi. Reducing visual clutter as much as possible by collocating Installations onto existing infrastructure.
- vii. Maintaining the consistency of character of the neighborhoods in Cambridge.

B. Types of Poles.

- i. Single Acorn Pole: A pole similar in design as depicted in Exhibit V(B)(i), attached hereto.
- ii. Double Acorn Pole: A pole similar in design as depicted in Exhibit V(B)(ii), attached hereto.
- iii. Cobra Head Pole: A pole similar in design as depicted in Exhibit V(B)(iii), attached hereto.
- iv. 1907 Tear Drop Roadway Pole: A pole similar in design as depicted in Exhibit V(B)(iv), attached hereto.
- v. Single Saturn Pedestrian Pole: A pole similar in design as depicted in Exhibit V(B)(v-vi), attached hereto.
- vi. Double Saturn Pedestrian Pole: A pole similar in design as depicted in Exhibit V(B)(v-vi), attached hereto.
- vii. Cree Edge Pole: A pole similar in design as depicted in Exhibit V(B)(vii), attached hereto.

- viii. Gas Lamp Pole: A pole similar in design as depicted in Exhibit V(B)(viii), attached hereto.
- ix. Large Square Light Pole: A pole similar in design as depicted in Exhibit V(B)(ix), attached hereto.
- x. Vassar Street Contemporary Pole: A pole similar in design as depicted in Exhibit V(B)(x), attached hereto.
- xi. The Single Acorn Pole, Double Acorn Pole, Single Saturn Pedestrian Pole, Double Saturn Pedestrian Pole, Cree Edge Pole, Vassar Street Contemporary Pole, and the Gas Lamp Poles shall be considered "Decorative Poles."

C. Siting Requirements. All Installation(s) shall comply with the following requirements.

- i. No Installations, other than a collocation at the same location, shall be located closer than 150 feet radially from another Installation, unless the Applicant proves with substantial evidence that locating further than 150 feet from another Installation would constitute an effective prohibition of wireless services, and that collocation with an existing Installation within that radius is impracticable.
- ii. In commercial districts and major city squares such as Harvard Square, Central Square, Inman Square, Porter Square and Kendall Square, an Installation shall not be located directly adjacent to a preexisting pole with a previously approved Installation, unless the Applicant proves with substantial evidence that this restriction would constitute an effective prohibition of wireless services.
- iii. Installations shall be placed on existing non-decorative light poles, with preference for the 'Cobra Head' poles first, and then to '1907 Teardrop' poles, then to Large Square Light Poles. Any use of Decorative Poles shall be disfavored. The Application will be denied unless the Applicant proves with substantial evidence that deviating from this order of preference would constitute an effective prohibition of wireless services.
- iv. All equipment associated with an Installation shall be consistent with ADA regulations. Installations shall not obstruct ADA access and circulation including maintaining clear landing at the top of crosswalk curb ramps and minimum distance between the base of the new Installation and any other obstruction such as building walls or other elements and shall not incommode the public way.
- v. No Installation shall be located less than 6 feet from an existing building wall unless the Applicant proves with substantial evidence that this restriction would constitute an effective prohibition of wireless services.

- vi. No equipment associated with the Installation, including backup power supply or base equipment cabinet or shroud shall be installed in the pedestrian walking area or amenity zone of the sidewalk, where site furniture including seating or bike racks are located, unless the Applicant proves with substantial evidence that this restriction would constitute an effective prohibition of wireless services.
- vii. Where possible, Installations shall be in a straight line with existing utility poles, street lights and street trees in the right of way.
- viii. No new Installation or any related structures shall be placed less than 6 feet away from the edge of a driveway of a residential or commercial property; and shall be placed at least 15 feet from the outer edge of the curb at any intersection of two or more public rights of way, unless the Applicant proves with substantial evidence that this restriction would constitute an effective prohibition of wireless services.
- ix. Installations shall not be placed within 6 feet of a residence's window, door openings, porches or balconies, unless the Applicant proves with substantial evidence that this restriction would constitute an effective prohibition of wireless services.
- x. No Installation shall be placed where, in the determination of the City, it would limit the City's ability to plant future street trees based upon the existing City plans for planting of street trees.
- xi. No Installation shall be placed where, in the determination of the City, it would limit the City's ability to install any city infrastructure, transportation elements or facilities including bike lanes, bike racks or other street furniture and the like based upon existing City plans for installation of such facilities.
- xii. Where the City has planned a redevelopment or change to a street, sidewalk, square, or other area of the City, Applicants shall remove their Installation at their own cost upon reasonable notice by the City, and may apply to place their Installation in a different location upon the City's redevelopment or change to such area, but in an emergency such as a flood, hurricane, war, or other such emergency, Applicant shall remove their Installation immediately.
- xiii. In residential zoning districts, Installations shall not be placed directly in front of a building. Where there is a side yard setback with open space or other space, preference shall be given to applications to locate an Installation on the public way in front of a side yard setback, unless the Applicant proves with substantial evidence that locating the Installation in front of a side yard setback would constitute an effective prohibition of wireless services.
- xiv. For properties under the jurisdiction of the Cambridge Historical Commission, Applicants for Installations shall obtain written authorization from the Cambridge

Historical Commission Applicants shall submit all required materials to the Historical Commission and the Community Development Department contemporaneously with any Application made under this Policy.

- xv. Applicants of proposed Installations must consider other optional siting locations to avoid placing Installations in front of storefront windows, primary entrances, exits, in front of primary walkways or area in such a manner that would hinder service to the building or delivery.
- xvi. In residential zoning districts, new poles for Installations must be located at the lot line between properties.
- xvii. New Installations shall not be placed where they obstruct the sight line of any intersecting street or public alley. A minimum of fifteen feet (15') shall be maintained between the new Installation and the outside edge of the street curb or public alley.
- xviii. The design and location of Installations shall be consistent with the current Manual on Uniform Traffic Control Devices (MUTCD) and adopted Cambridge standards for intersections' sight lines triangles.
- xix. Siting for utilization of existing utility or City-owned poles or other City-owned property for Installations will be given priority, and any requests to install a new Installation or other structure in the public way shall be denied unless the Applicant proves with substantial evidence that this restriction would constitute an effective prohibition of wireless services. Specifically, Applicants seeking installation of new poles are expected to document why neither collocation upon, or replacement of, an existing pole proximate to the proposed location is practicable, thus necessitating the addition of additional poles to the public way.
- xx. All Installations shall comply with all local, state, and federal rules, laws and regulations.

VI. Pole Design and Overall Height

- A. If Installations are proposed to be mounted on any of the City's existing single Acorn or single Saturn poles, Cree Edge Poles and Gas Lamp Poles, the existing pole shall be replaced with a double luminaire fixture of the same design for purposes of aesthetics. The antenna on these poles shall be of a "whip antenna" design, which antenna shall be no higher than 30 inches high by 2 inches in diameter and shall have an antenna mount no more than 45 inches high by 4.5 inches in diameter, and shall be located directly in between the luminaire fixtures.
- B. If the Applicant proposes to replace an existing Decorative Pole with a new Installation, the Applicant shall replicate to the maximum extent possible the existing pole design and overall dimensions.

- C. With respect to Cobra Head poles, all antennas, equipment, wiring and cabling shall be built within the pole itself, which allow for multiple carriers in one pole.
- D. Any Installations at the site of an existing pole shall not extend the overall height of the pole by more than 10% of the existing pole height, except for "whip antennas" which shall be no higher than 30 inches high by 2 inches in diameter and shall have an antenna mount no more than 45 inches high by 4.5 inches in diameter, and except for Installations upon Large Square Light Poles, which may be more than 30 feet high, but shall not extend the overall height of the pole to more than nearby Large Square Light Poles.
- E. In residential zoning districts, top mounted antennas on Installations shall not increase the height of the existing pole by more than 5 feet.
- F. No Installation shall be more than 10% higher than other adjacent poles, except for Installations upon Large Square Light Poles, which shall not extend the overall height to more than nearby Large Square Light Poles.

VII. Equipment Cabinet, Equipment Shroud, Antenna and Antenna Shroud

- A. Where technically feasible, equipment, cables and wiring for Installations shall be located underground. The foregoing undergrounding requirement does not apply to elements of an Installation which must, by necessity, be located aboveground, such as antennae, radio units, and cable runs connecting such equipment to underground equipment vaults.
- B. Any above ground or pole mounted equipment cabinet or shroud shall be no more than 36 inches high, no more than 18 inches wide and no more than 12 inches deep. Any above ground or pole mounted equipment cabinet or shroud shall be installed with the 18 inches side parallel to the sidewalk. Hardware, anchors and straps to the pole shall match the pole color and finish.
- C. Equipment cabinets or shrouds shall be pole mounted at least 10 feet high on Installations which are less than 25 feet high, or at least 12 feet high on Installations which are greater than 25 feet high.
- D. Pole mounted equipment cabinets or shrouds shall not be mounted on the street side of the Installation.
- E. Antennas of Installations greater than 25 feet high shall be no more than 24 inches high by 16 inches in diameter.
- F. Antennas, conduits, brackets and hardware shall be hidden from view. All associated wiring and cable shall be installed within the Installation, except for

Installations upon a wooden pole, which in such case, wiring and cabling shall be shrouded and painted to match the wood on the pole.

- G. Antennas mounted on Installation which are greater than 25 feet high shall include a tapered transition piece between the antenna and the pole top for a seamless extension of the existing pole. The tapered transition piece shall be no more than 16 inches in diameter and 24 inches high.
- H. Antenna enclosures on Installations that are more than 25 feet high shall be no wider than 150 percent of the diameter of the pole or support structure and shall not be more than 16 inches in diameter or whichever is less, and shall be no more than 24 inches in length.
- I. Antenna mounted on top of Installations that are less than 25 feet high shall be a "whip antenna," and be no greater than 30 inches high nor greater than 2 inches in diameter and shall have an antenna mount no greater than 45 inches high nor greater than 4.5 inches in diameter.
- J. Installations, including but not limited to the ventilation equipment within the shroud or cabinet, must comply with the City of Cambridge Noise Control Ordinance. If an Installation is in violation of the City of Cambridge Noise Control Ordinance and cannot be brought into compliance, the Installation must be removed and any City property, including the public way, restored to the condition prior to the Installation, in accordance with all City standards, and at Applicant's expense.

VIII. Color, Finish, Signage, Logos and Decals

- A. All Installations shall match the existing and adjacent street light poles' colors to the greatest extent practicable.
- B. No exposed wires or conduit shall be permitted on any Installation except on existing wooden poles; and if Installations are installed on existing wooden poles, they must conform to the utilities' 'Construction Requirements for Distributed Antenna Systems (DAS) on Electric Distribution Poles.'
- C. No Signage/Decals or Logos of the Applicant, other than FCC required signage, shall be placed on any Installation.
 - i. Signage: Unless required otherwise by state, federal or local laws, rules or regulations, signage shall not exceed 4 inches by 6 inches and must be attached or anchored with material to match the pole color and finish of the Installation. Applicant shall only post its or the manufacturer's name, location, pertinent and emergency contact information in an area on the equipment or shroud that is visible to the public and shall do so only as permitted or required by state, federal or local laws, rules or regulations.

Where no equipment cabinet or shroud exists on an Installation, the signage shall be located at the base of the Installation.

- ii. Applicants shall remove or paint over manufacturer decals without compromising the surface, color or finish of the Installation's base material. The color and finish of the Installation shall match or be as approved by Cambridge Historical Commission staff. No advertisement for the Applicant or manufacturer of the Installation shall be allowed except displaying information as permitted or required by federal, state or local laws, rules or regulation.
- iii. Required equipment warning stickers: Applicants shall use only the smallest and lowest visibility warning stickers allowed by federal, state, local laws, rules or regulations.
- iv. Equipment cooling fans: In residential zoning districts, if equipment cooling fans are required, the Applicant shall use equipment cooling fans with the lowest noise level and shall not exceed the levels allowed in the City's noise ordinance.

IX. Miscellaneous Provisions

A. If an Application is granted or granted with conditions, the Applicant may be required to comply with certain conditions or be required to obtain additional permits from other City Departments prior to completing the Installation. Failure to comply with any conditions or the good faith application for required permits from other City Departments may be the basis for the revocation of a grant of location or may render a finding that in the Applicant is in non-compliance with the Small Cell Policy and the Installation(s) will not be allowed to be installed or that such Installation(s) will have to be removed and the Applicant will have to restore the public way to the condition prior to the Installation, in accordance with all City standards, and at Applicant's expense.

B. If any provision of this Small Cell Policy is deemed null, void or unenforceable by a court of competent jurisdiction, the remainder of the Small Cell Policy shall remain in full force and effect.

C. The Commission may grant any application inconsistent with the requirements of Sections IV, V, VI, VII, or VIII where necessary to avoid a violation of applicable law. Where an Applicant submits an Application it knows is inconsistent with one or more requirements of this Policy, such Application must specify those provisions for which it seeks waiver, and must include specific explanations as to the need for waiver of each, including explaining why compliance with the requirement(s) would prohibit or effectively prohibit the provision of services as protected by applicable law.

Nicole Murati Ferrer
Chairperson

Stephen Lenkauskas
City Electrician

Terrence James Shea
Superintendent of Streets

CITY OF CAMBRIDGE POLE AND CONDUIT COMMISSION

831 Massachusetts Avenue, Cambridge, Massachusetts 02139

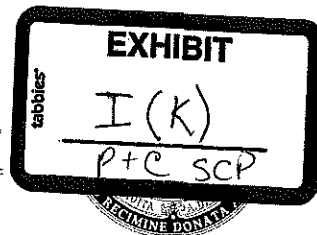

Elizabeth Y. Lint
Executive Director of
License Commission

TOLLING AGREEMENT RELATIVE TO SMALL CELL INSTALLATION PETITION

The following agreement is being made by Petitioner _____ (the "Petitioner") with the City of Cambridge Pole and Conduit Commission (the "Commission"), as to Petition # _____ which was before the Commission for its consideration on _____. The Petitioner and the Commission enter this Tolling Agreement ("Agreement") willingly, voluntarily and pursuant to the Telecommunications Act of 1996, Pub. Law No. 104-104, 110 Stat. 56 (1996), codified in various sections of Title 47 of the Code of Laws of the United States (the "Act"), the Federal Communication Commission's Declaratory Report and Third Report and Order, dated September 26, 2018, M.G.L. c. 166, §22, the Commonwealth of Massachusetts' Special Acts of 1922, Chapter 213, the Cambridge Municipal Code Chapter 15.16, the Commission's Policy Regarding Small Cell Wireless Installations on the Public Way (the "Small Cell Policy"), and other applicable federal, state and local laws, rules regulations, or orders.

The Commission and the Petitioner (collectively hereinafter referred to as "the Parties") hereby mutually agree that the Petition will be continued for a minimum of sixty (60) days, and that any deadlines required by federal, state, or local law shall be extended for a minimum of seventy-five (75) days from the date of execution of this Agreement. The Parties, therefore, agree that the Petition will be placed on the Commission's next available hearing _____ days after the execution of this Agreement ("the extension"). In addition, the Parties agree that any deadlines required by federal, state, or local law shall be consequently extended for fifteen additional days from the extension. The Parties further agree:

- (a) The Agreement is only valid as to the Petition identified above;
- (b) The Agreement may be subsequently amended by the Parties in writing; and
- (c) If any provision of this Agreement is deemed null, void or unenforceable by a court of law of competent jurisdiction over the matter, the remainder of the provisions shall remain in full force and effect.

For the Pole and Conduit Commission

For the Petitioner

Chairperson

Name:

Title:

Dated: _____

Dated: _____

Single Acorn

EXHIBIT
tabbles
V(B)(1)
100-20

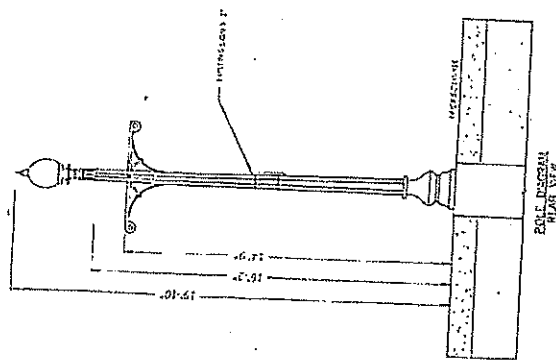
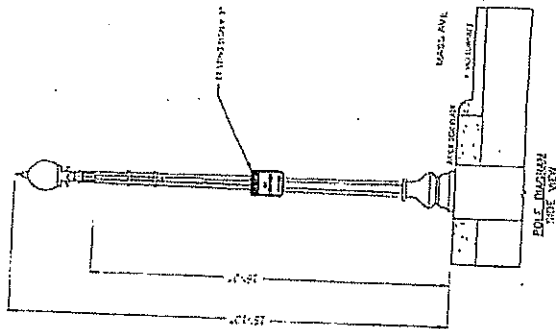
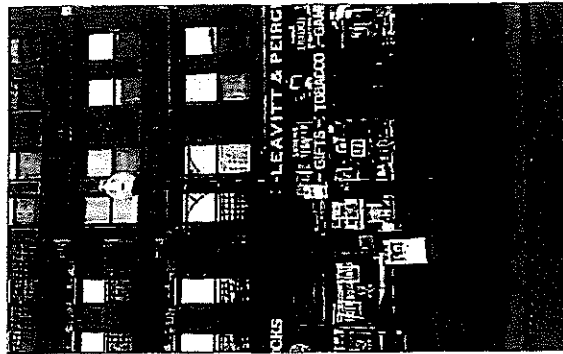

Double Acorn

EXHIBIT
tabbles
V(B)(ii)
pic set

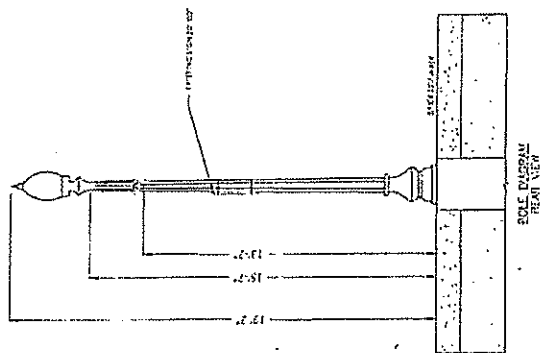
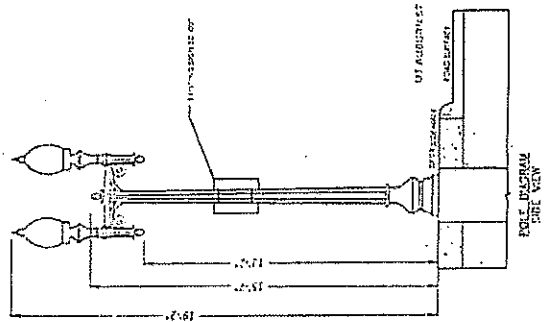
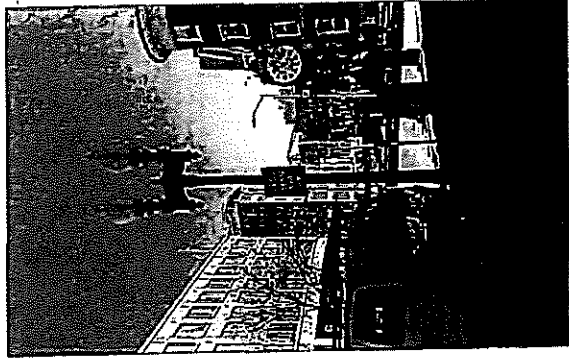

Cobra Head Pole



EXHIBIT
 tabbles
 VLB (in)
 142-507

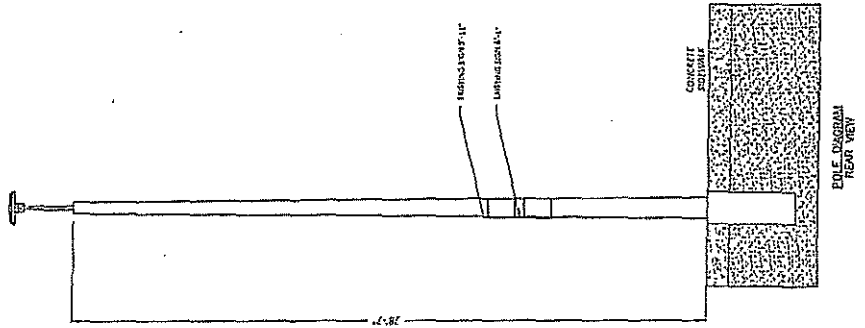
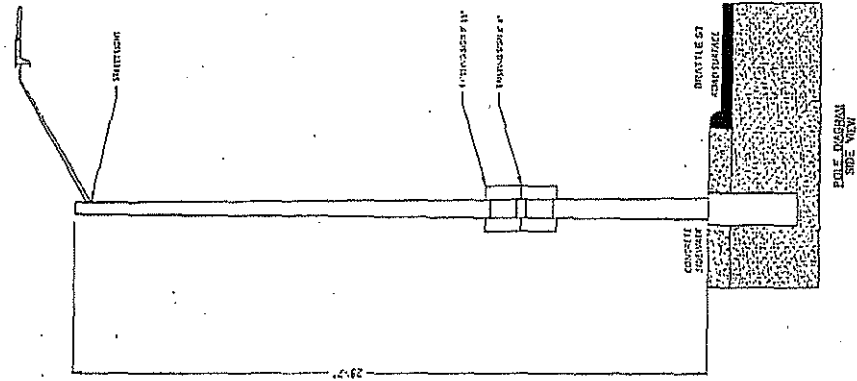

1907 Tear Drop

EXHIBIT
tabbles
V(B)(iv)
PAC-SCP

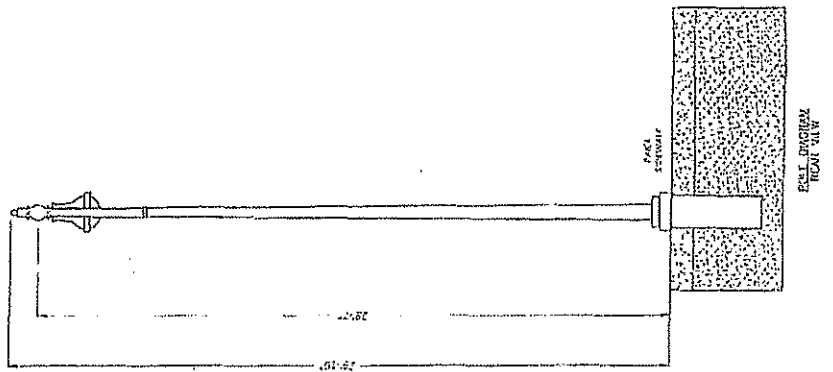
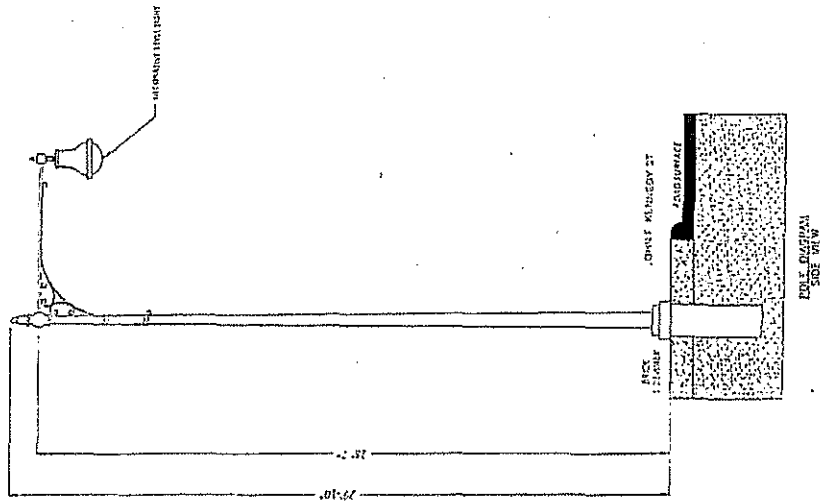
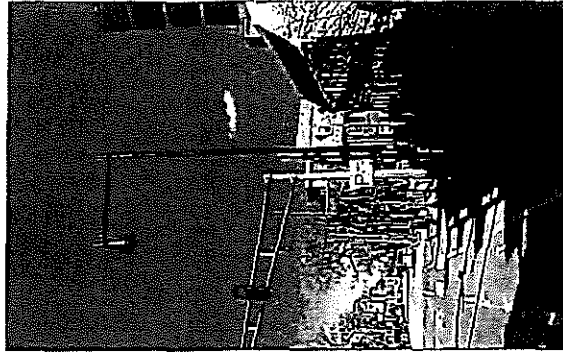
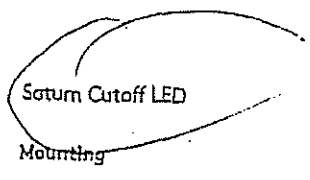

EXHIBIT
 V(D)(v-vi)
 PCC-SCP

Selux Saturn



selux

Single (S)
 Die-cast aluminum filter base secured to pole with three stainless steel, Allen head set screws.

EPA = 1.3ft² (0.12m²)
 Weight = 39lbs. (17.7kg)

Single Arm Mount (1A)
 Die-cast aluminum single luminaire mounting arm secured to pole with four stainless steel, Allen head set screws. Outer slip fitter for 3/4" O.D. tenon.

EPA = 2.31ft² (0.21m²)
 Weight = 53lbs. (24.0kg)

Double (2)
 Die-cast aluminum double luminaire mounting arm secured to pole with four stainless steel, Allen head set screws. Outer slip fitter for 3/4" O.D. tenon.

EPA = 4.2ft² (0.39m²)
 Weight = 176lbs. (79.8kg)

Wall (W)
 Die-cast aluminum double round wall mount arm. Secured to wall with 1/2" diameter threaded fasteners (by others).

EPA = 2.1ft² (0.20m²)
 Weight = 50lbs. (22.7kg)

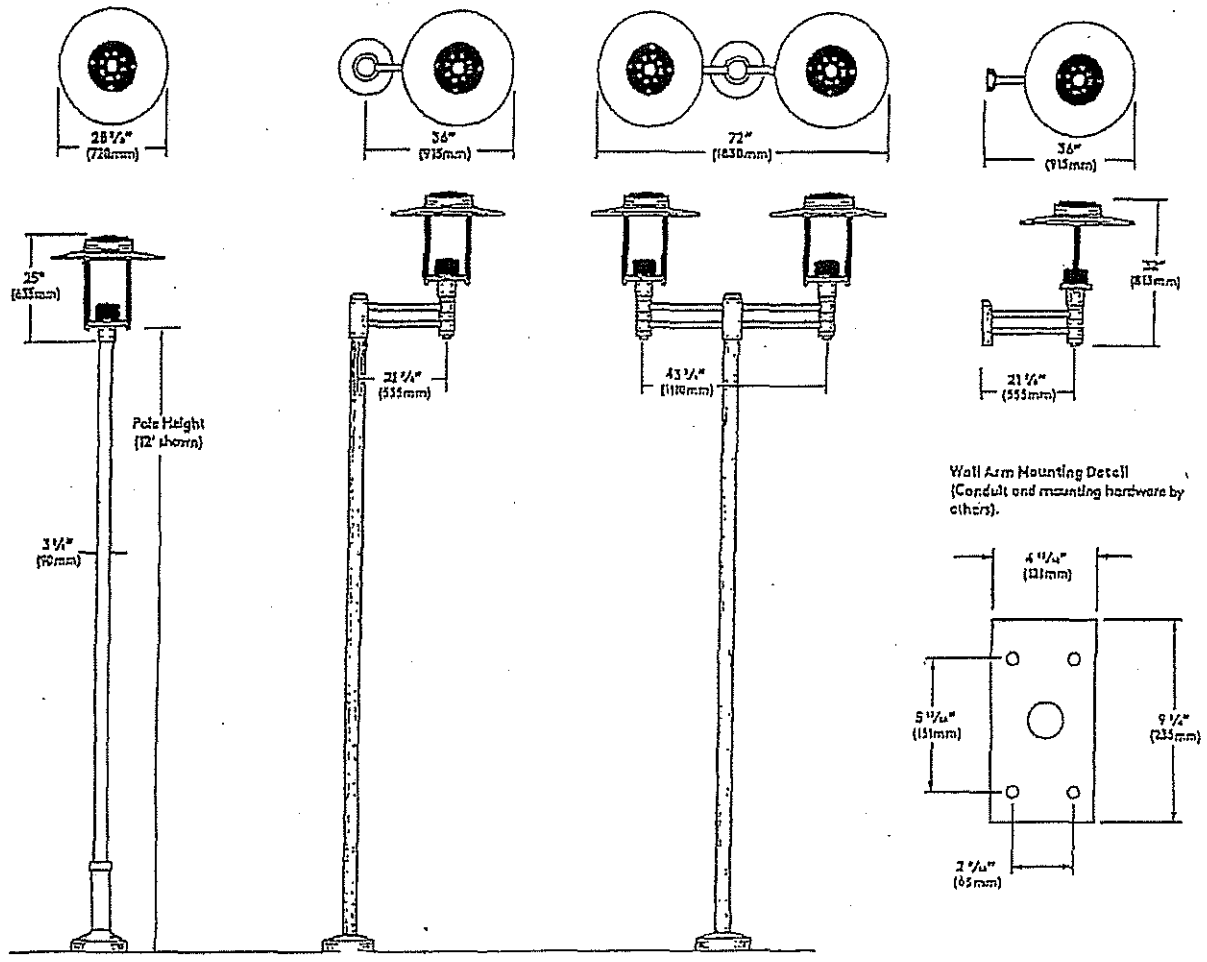

Cree Edge

EXHIBIT

tabbles

V(2)(vii)
PRE-SEP



EXHIBIT

tabbies

V(CB)(VIII)
1900-1901

Gas Lamp

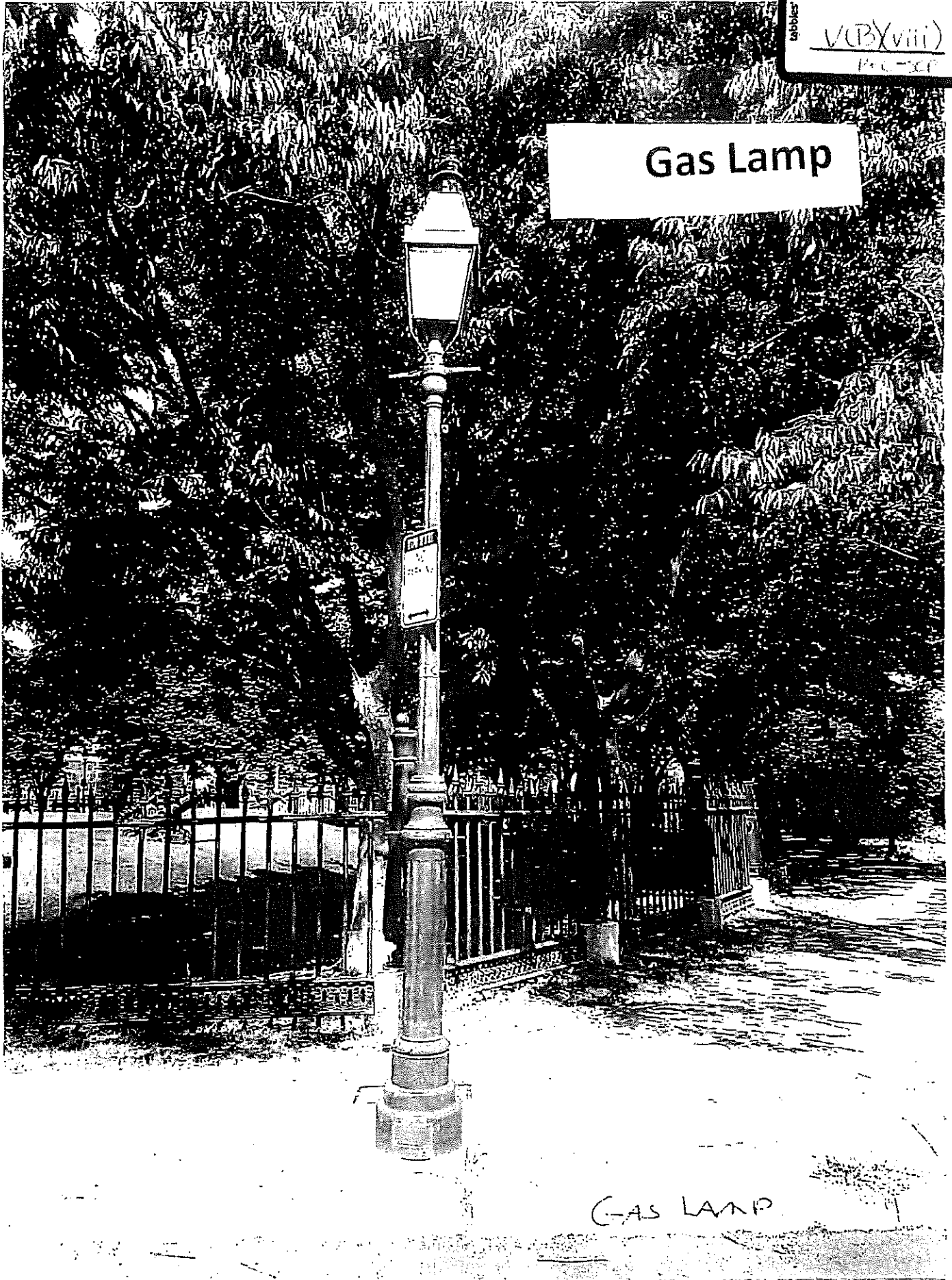

GAS LAMP

Large Square Light Pole

EXHIBIT
tabbles
V(B)(ix)
140 SCP

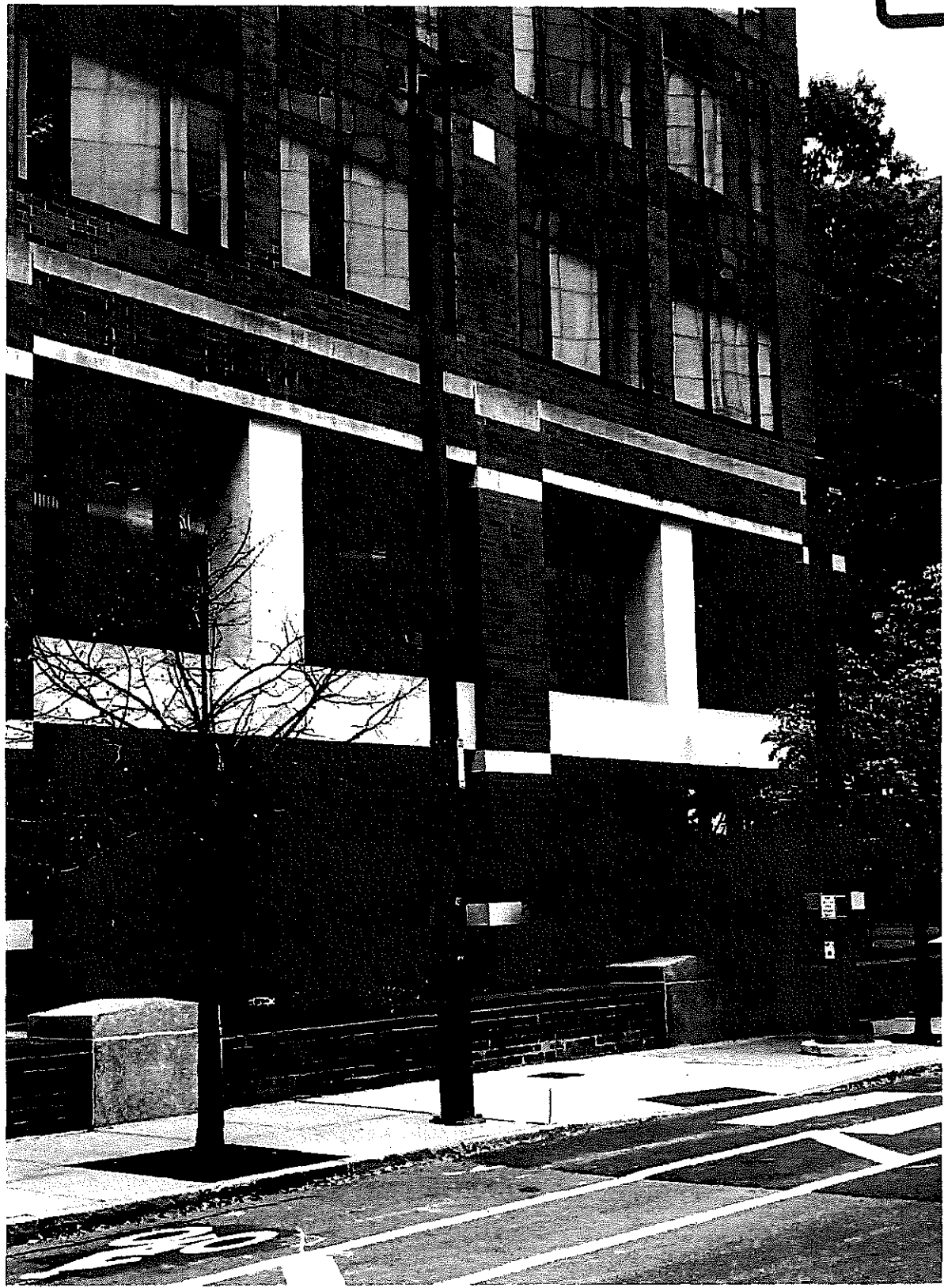

Vassar Street Contemporary Pole

EXHIBIT
tabbies
V(B)(x)
P-C SCP



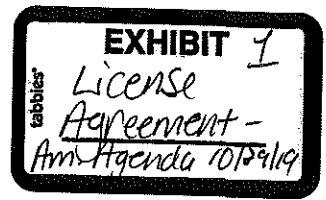

LICENSE AGREEMENT

Licensor: City of Cambridge
City Hall
795 Massachusetts Avenue
Cambridge, MA 02139

Licensee: (Name)
(Full Address)
(Phone Number)
(Email)

THIS License Agreement (“Agreement” or “License” or “License Agreement”) is entered into as of _____, 20____, by and between the **City of Cambridge**, a municipal corporation in the Commonwealth of Massachusetts (hereinafter “Licensor” or “City”), and

(hereinafter “Licensee”).

WHEREAS, the Licensee wishes to access and utilize the public way underneath and surrounding and near a utility pole, including the City’s air rights above the public way, and/or a City pole or other structure, located at

in Cambridge, MA (“Approved Wireless Facility” or “Installation” as further defined in paragraph 2 below).

1. Definitions. The following definitions shall apply generally to the provisions of this Agreement:
 - a. “Approval” shall mean each separate authorization, granted by Licensor to Licensee with regard to a specific Equipment installation, each and every of which shall be subject to the terms and conditions of this Agreement.
 - b. “Equipment” means the equipment cabinets, antennas, utilities, and fiber optic cables, wires, and related equipment, whether referred to individually or collectively, to be installed on a Municipal Facility and operated by Licensee under a particular Approval.
 - c. “Hazardous Substance” means any substance, chemical or waste that is identified as hazardous or toxic in any applicable federal, state or local law or regulation, including, but not limited to, petroleum products and asbestos.
 - d. “Laws” means any and all applicable statutes, codes, constitutions, ordinances, resolutions, regulations, judicial decisions, rules, tariffs, administrative orders, court orders, or other requirements of the Licensor or other governmental agency having joint or several jurisdiction over the parties to this Agreement as such laws may be amended from time to time.

- e. "License Fee" means the compensation paid under any Approval for use of the Municipal Facilities.
- f. "Make-Ready Work" means the work required on or in a Municipal Facility to create space for the Equipment, and/or replacing and/or reinforcing the existing Municipal Facility to accommodate Equipment including, but not limited to, rearrangement or transfer of existing Equipment and the facilities of other entities, and Municipal Facility relocation and replacement if applicable.
- g. "Municipal Facility (ies)" means Licensor-owned structures, objects, and equipment in the ROW, including, but not limited to, street lights, traffic control structures, banners, street furniture, bus stops, billboards, or other poles, lighting fixtures, or electroliers located within the ROW, and may refer to such Municipal Facilities in the singular or plural, as appropriate to the context in which used.
- h. "Person" means and includes any individual, partnership of any kind, corporation, Limited Liability Company, association, joint venture, or other organization, however formed, as well as trustees, heirs, executors, administrators, or assigns, or any combination of such persons.
- i. "Right(s)-of-Way" or "ROW" means the improved or unimproved surface or subsurface of any public street, or similar public way of any nature, dedicated or improved for vehicular, bicycle, and/or pedestrian related use. Right-of-Way includes public streets, roads, lanes, alleys, sidewalks, medians, parkways, public utility easements, and landscaped lots. The Public Right-of-Way does not include private ways.
- j. "Services" means the transmission and reception of communications signals for the provision of personal wireless services, telecommunications services and mobile data services as defined in federal law, but specifically excluding cable services as defined in 47 U.S.C. § 522(6).
- k. "Transfer" means any transaction in which the rights and/or obligations held by Licensee under this Agreement or an Approval are transferred, directly or indirectly, in whole or in part to a party other than Licensee.

2. Term and Termination of License Agreement.

The term of this License Agreement is a period of five (5) years, commencing on the date of execution by both Parties (the "Term"). In the event that the Licensee decides to remove its Equipment at the end of the Term, the term shall extend for ten (10) additional days during which time the Licensee may remove its Equipment and restore the public way and any utility pole(s), subject to proration of any amounts owed as described herein, and subject to the provisions of this License Agreement as further described herein. Licensee agrees that notwithstanding the foregoing, where the City has planned a redevelopment or change to a street, sidewalk, square, or other area of the City and the City informs the Licensee in writing that the City is terminating this License as a result thereof prior to the expiration of the five year Term, Licensee shall remove its Installation forthwith at its own cost and may apply to re-install its Installation in a different location after the City's redevelopment or change to such area.

3. Representation Concerning Services; No Authorization to Provide Other Services.

Licensee represents, warrants, and covenants that its Equipment installed pursuant to this Agreement and each Approval will be utilized solely for providing the Services, and Licensee is

not authorized to and shall not use its Equipment installed on Municipal Facilities to offer or provide any other services not specified herein without Licensor's prior written consent. At any time that Licensee ceases to operate as a provider of Services under federal or state law, it shall provide written notice of the same to Licensor within seven (7) days of such cessation, at which time the Licensor shall have the option, in its sole discretion and upon ten days' written notice to Licensee, to terminate this Agreement and to require the removal of Licensee's Equipment from the ROW and from Municipal Facilities, including the cost of any site remediation, at no cost to the Licensor, without any liability to Licensor related directly or indirectly to such termination. Licensee agrees that any failure to notify the Licensor as provided herein shall result, in addition to any damages incurred by the Licensor, an amount of liquidated damages in the amount of \$100.00 per day until the date upon which the Licensor is properly notified as provided herein.

4. Grant of Location.

Subject to the conditions herein, Licensor hereby authorizes and permits Licensee to locate, place, attach, install, operate, maintain, repair, control, remove, reattach, reinstall, relocate, and replace Equipment on identified Municipal Facilities located in the ROW for the purpose of providing Services pursuant to and subject to any limitations or requirements of any grant of location by the Pole and Conduit Commission. If Licensee's Municipal Facility is structurally inadequate or otherwise unsuitable to accommodate its proposed Equipment, Licensor may permit the replacement of the Municipal Facility (a "Replacement Facility") with one that is acceptable to and approved by the Licensor as part of the applicable Approval. Any Replacement Facility shall be installed and maintained in accordance with this Agreement.

5. Unmetered electricity where possible.

Licensee shall be solely responsible for obtaining and maintaining the provision of electricity to the Equipment, including, but not limited to, making payments to electric utilities. Licensee acknowledges that operation of any street lights is part of the camouflage requirements of the facility, and Licensee shall pay for all electricity required for its wireless services and for the street light for purposes of camouflage. Where commercially feasible and available, Licensee shall secure unmetered electricity services.

6. Additional Authority.

Nothing in this Agreement shall limit in any way Licensee's obligation to obtain any additional required regulatory approvals or permits from any state or federal department or agency, or any City department, board, commission, or other governmental agency that has regulatory authority over the Licensee's proposed activities involving use of the Municipal Facilities in the ROW.

7. No Interference.

Licensee acknowledges and agrees that the primary purpose of the Municipal Facilities is to serve the Licensor and the public. In the performance and exercise of its rights and obligations under this Agreement, Licensee shall not interfere in any manner with Licensor's own services or the existence and operation of any and all public and private rights-of-way, sanitary sewers, water mains, storm drains, gas mains, poles, aerial and underground electrical and telephone wires, traffic signals, communication facilities owned by the Licensor, electroliers, cable television, location monitoring services, public safety and other then existing

telecommunications equipment, utilities, or municipal property, without the express written approval of the owner or owners of the affected property or properties, except as permitted by applicable laws or this Agreement. If such interference should occur, Licensee shall discontinue using the Equipment, methodology, or technology that causes the interference until such time as Licensee takes corrective measures to eliminate such interference. In the event that such interference does not cease within three business days after notice, Licensee acknowledges that continuing interference may cause irreparable injury and harm, and therefore, in addition to any other remedies, and without limitation of any other remedy, Licensor shall be entitled to terminate the Service and remove any equipment upon the Municipal Facilities, with no liability on the part of the Licensor for any damage to any property or person of the Licensee..

8. Permits; Default.

In addition to any other remedies available hereunder, whenever Licensee is in default of this Agreement or an applicable Approval, after notice and applicable cure periods, Licensor may deny further encroachment, excavation, or similar permits for work in connection with installations under this Agreement until such time as Licensee cures all of its defaults.

9. Compliance with Laws.

Licensee shall comply with all federal, state and local laws and regulations in the exercise and performance of its rights and obligations under this Agreement.

10. Non-Exclusive Use Rights.

Notwithstanding any other provision of this Agreement, any and all rights expressly or impliedly granted to Licensee under this Agreement shall be non-exclusive, and shall be subject and subordinate to (1) the continuing right of the Licensor to use, and to allow any other person or persons to use, any and all parts of the ROW or Municipal Facilities, exclusively or concurrently with any other person or persons, and (2) the public easement for streets and any and all other deeds, easements, dedications, conditions, covenants, restrictions, encumbrances, and claims of title (collectively, "Encumbrances") which may affect the ROW or Municipal Facilities now or at any time during the term of this Agreement, including, without limitation any Encumbrances granted, created, or allowed by the Licensor at any time. During the Term of this Agreement, the City hereby grants Licensee the non-exclusive right to enter and to use the public right of way to attach, install, construct, maintain and operate a wireless facility at the above-described location/s (hereinafter "Approved Wireless Facility") in accordance with this License Agreement. In the event that the Federal Communications Commission's Declaratory Ruling and Third Report and Order, Adopted September 27, 2018 is overturned, or the law otherwise changes with respect to the legal requirements with respect to any Approved Wireless Facility, then Licensor shall have the option to cancel this License with 10 days' notice to Licensee.

11. Aesthetic Requirements.

Any Approved Wireless Facility shall comply with the aesthetic requirements of the City, in a manner that is in compliance with any grant of location by the City's Pole and Conduit Commission. Any Approved Wireless Facility shall be camouflaged in the manner as directed by the City. Licensee hereby agrees that the size, shape, and coloring are all elements of camouflage, and any change to such size, shape, and coloring must be pre-approved in writing by the City.

12. Obtaining Required Permits.

Licensee acknowledges that in addition to a signed Approval, each installation of Equipment and maintenance thereof shall also be subject to then-current City permitting requirements as set out in any federal, state, or City or regulation. Licensee agrees to comply with the current applicable ordinances and regulations regarding such Installations and maintenance as well as any future regulations that may be adopted by the City related to such Installations and maintenance. Licensee shall apply for the appropriate permits and pay any required permit fees.

13. Change in Equipment.

If Licensee desires to install Equipment which is different in any material way from the then-existing and approved Equipment, then Licensee shall first obtain the written approval for the use and installation of such Equipment from an authorized representative of the Licensor. Any such approval shall take the form of an amendment to the applicable Approval. In addition to any other submittal requirements, and if requested by Licensor, Licensee shall provide "load" (structural) calculations for all Equipment changes. In addition to the foregoing, Licensee shall comply with any other applicable City permitting or approval process for the Equipment change.

14. Unauthorized Equipment.

If Licensor discovers that any Equipment has been installed on Municipal Facilities without authorization pursuant to an Approval or grant of location by the Pole and Conduit Commission, Licensor may send an invoice to Licensee for a sum equal to five (5) times the then-current License Fee as compensation for the unauthorized attachments, and, within sixty (60) days from the date of such invoice, Licensee shall (a) pay the invoiced amount to Licensor and submit an Application for the unauthorized Equipment, or (b) produce documentation showing Licensor's prior approval of the Equipment identified in the invoice. If, in accordance with this Section, Licensee fails to pay all fees and submit the Application or submit documentation satisfactorily showing Licensor's prior approval within sixty (60) days of Licensor's invoice, Licensor may remove the unauthorized Equipment at Licensee's expense. If Licensor removes such unauthorized Equipment, such Equipment shall become the property of Licensor, who shall have sole rights over such Equipment's disposition. Licensor's removal of unauthorized Equipment shall not release Licensee from its obligation to pay those invoiced fees accruing pursuant to this Section.

15. Insurance and Indemnification.

Licensee and its agents, employee, partners, directors, members, agents, employees, contractors, third parties and/or guests ("Licensee") shall indemnify, hold harmless, release and defend the City, its officials and employees from and against all claims, damages, accusations, complaints, injuries (including worker's compensation), property damage, requirements to respond to inquiries, breach of contract, violation of law, or other losses and expenses, including but not limited to attorney's fees, which arise out of or result directly or indirectly, from the Licensee's use of the public way, the ground underneath the public way, and/or, any air rights above the public way, or with regard to any other matter in any way related to this License and/or Licensee's application or operation of Licensee's equipment or facility or emissions therefrom, or any other matter arising from Licensee's agreement, responsibilities, conduct, acts or lack thereof, including but not limited to any claims or complaints related to any

discrimination, alleged defects in the public way wireless or radio interference issues, radiation exposure issues, violation of any telecommunications law or other federal, state or local law, rule or regulation, or FCC order or any other regulation or administrative provision or otherwise, or any other of Licensee's requirements or responsibilities, or lack of compliance thereof, whatsoever, whether any such claims or damages are caused by the City's negligence, reckless or willful misconduct or not, brought by any entity, agent, employee, person, governmental agency, other licensee or other member of the public. By this, Licensee agrees to comply with all federal, state, and local laws, rules and regulations, including procurement of any required licenses, permits, or any other authorizations. Licensee agrees to provide the City with any documents required by any law or in compliance with any request by the City. Licensee shall hire and pay for counsel of the City's choosing to defend and/or represent the City with regard to any such complaints, claims, requests, requirements, or allegations, including for any responses required by any law, rule, or regulation, or any other matter, action, claim or complaints related to any of the above referenced matters herein. The City, its employees, departments, officers, directors, boards, commissions or its agents shall not be liable to Licensee for any claims, causes of action, lawsuits or injury or damage or any other cause of whatever nature arising from or related to this License, nor shall the City be liable to Licensee for any such damage caused by the City or any other person with regard to any matters related hereto, whether caused by negligence, reckless or willful misconduct or not, and Licensee shall hire and pay for counsel of the City's choosing to defend and represent the City with regard to any such complaints, inquiries, claims or allegations.

The parties hereto agree that this License Agreement shall be governed by the laws of the Commonwealth of Massachusetts, and any disputes shall be settled in the state courts of the Commonwealth of Massachusetts, without regard to conflict of law principles, with counsel for the City hired and paid by the Licensee. Licensee agrees that City street lights and any other structure in the public way or otherwise, must be kept operational, both for purposes of camouflage of the Approved Wireless Facility, and for safety and convenience of members of the public, and any damage to such structure, any use of double poles, or any failure of the street lights, including of any such light bulbs, or the failure to comply with any of the City's aesthetics or camouflage requirements for the facility or structure, maintenance or operation of the facility or otherwise, as determined by the City in its sole discretion, must be maintained and repaired immediately, and Licensee agrees to be subject to liquidated damages of \$100.00 per day after notice by the City of any street light malfunction, brightness, color temperature, timing or other issue, damage, or repair needed, whether any such malfunction, damage or failure is caused by any City employee, third party, utility, act of nature, or otherwise. Licensee agrees that any street light is required to be lighted in accordance with any schedule determined by the City, which may change seasonally or by the day, and must be dimmed or brightened depending on the time schedule as determined by the City. Licensee further agrees that the light shall be of a color temperature as directed by the City. Any lighting shall be of an LED or equivalent form of lighting with respect to energy efficiency. Licensee agrees to conduct maintenance and repairs solely at its expense, and which shall be separate and apart from any liquidated damages provisions herein, and if the City is required to perform such repairs due to Licensee's failure to do so within 10 days after notice, the Licensee shall reimburse the City's costs and expenses in conducting such maintenance and repair over and above the liquidated damages provisions herein, and shall fully indemnify the City as provided above. If requested by the City, Licensee

shall provide a \$10,000 retainer, to counsel of the City's choosing, for purposes of indemnification and representation of the City, with additional retainers to be paid by Licensee when such retainer has been expended below \$5,000, with regard to the aforementioned matters herein.

The Licensee agrees to obtain and maintain adequate insurance for its use of any Approved Wireless Facility and the public way for its activities. Licensee agrees to maintain general liability insurance in an amount not less than \$1,000,000 per occurrence and \$2,000,000 in the aggregate, worker's compensation insurance not less than the amount of \$100,000 per accident and \$500,000 per illness or the statutorily required amount, whichever is greater, and umbrella insurance in an amount not less than \$5,000,000. Licensee shall also provide a performance bond in the amount of \$1,000,000.00, which shall cover the City for any breaches by the Licensee with respect to any aspect of this Agreement. All such insurance coverage shall be maintained throughout the License Term and shall be required separately for each Installation or structure in the public way or otherwise. The insurers under such policies shall be satisfactory to the City and such policies shall name as insured parties the City and Licensee, and such policies shall indicate that the insurance company shall provide thirty (30) days' prior written notice to the City of lapse or cancellation. All insurance carriers shall carry an A.M. Best rating of "A-" or better. Such insurance shall provide for the waiver by the insurance carrier of any subrogation rights against City, its agents, servants and employees. The Licensee shall provide the City with a certificate of insurance of each insurance policy and shall provide a full copy of the insurance policy within seven (7) days of request by the City.

16. No Assignment.

Licensee hereby covenants and agrees that neither the License nor any interest herein or therein, shall be assigned, mortgaged, pledged, encumbered or otherwise transferred and that neither the Approved Wireless Facility, any City structure or the public way, nor any part thereof, shall be encumbered in any manner by reason of any act or omission of Licensee, or used or occupied, or permitted to be used for any other purpose other than as described in this License. The License shall not be sublet or offered or advertised for subletting, without in each case, the City's prior written consent. Any such individual or organization, including any parent companies, which sublets such space shall be required to sign a License Agreement with the City.

17. Changes to Approved Wireless Facility.

Licensee shall not make any alterations, additions, improvements, attachments, nor tape, nail, staple or otherwise decorate the Approved Wireless Facility, without the prior written consent of the City.

18. Notices.

Any notice or demand by Licensee to the City shall be served by registered or certified mail, with a return receipt, addressed to Licensor, to the attention of City Manager, City Hall, 795 Massachusetts Avenue, Cambridge, Massachusetts, 02139, to the Cambridge Board of License Commissioners, 831 Massachusetts Avenue, Cambridge, Massachusetts, 02139, and to the City Solicitor, City Hall, 795 Massachusetts Avenue, Cambridge, Massachusetts, 02139, and any notice or demand by City to Licensee shall be served by regular mail, email or in hand

addressed to Licensee at the address noted in this License Agreement or as noted in any correspondence or application form with the City.

19. Entire Agreement.

This License Agreement contains the entire agreement of the parties and may not be modified except by an instrument in writing, signed by the parties hereto.

20. Validity.

The invalidity of one or more of the provisions of this License Agreement shall not affect the remaining portions of this License Agreement, and if any one or more of the provisions of this License Agreement should be declared invalid by final order, decree or judgment of a court of competent jurisdiction, this License Agreement shall be construed as if such invalid provisions were not included herein but every other provision herein shall be considered valid and binding.

21. Choice of Law.

This License Agreement and any dispute arising out of or related to this Agreement or the use of any Authorized Wireless Facility, as well as the terms and conditions set forth in this Agreement, shall be governed and interpreted pursuant to the laws of the Commonwealth of Massachusetts, notwithstanding any principles of conflicts of law. Any dispute related to this agreement and/or the underlying application for installation of small cell wireless facilities, or any City policy or requirement for installation of wireless facilities, shall be brought, if at all, in the Commonwealth of Massachusetts, in the Middlesex Superior Court, and the parties hereto waive any rights to removal to any other court, notwithstanding any federal question or diversity jurisdiction, and with respect to any such dispute, the City shall be entitled to its attorneys' fees and costs, but the Licensee shall in no circumstance be entitled to its attorneys' fees or costs, and Licensee waives any right thereto.. This paragraph, and only this paragraph, shall be binding immediately upon execution of this Agreement by Licensee.

22. Counterparts.

This License Agreement may be signed in counterparts, each of which shall be considered an original execution.

23. City's Right to Cure.

In the event that the Licensee fails to comply with the terms of this Agreement and/or with any maintenance requirements, the Licensee agrees that the City may assume such responsibilities and repair and/or maintain the Approved Wireless Facility, and the Licensee shall reimburse the City for its expenses due to such assumption, in addition to any reimbursement required under Section 4 of this License Agreement.

24. Underground Connections.

There shall be no aerial cable connections to any Approved Wireless Facility. Any connections to the Approved Wireless Facility shall be made underground, subject to the Pole and Conduit Commission's, and any other City departments', requirements and prior approval for common access to any trenches needed for the Approved Wireless Facility.

25. Expiration of License.

Six months prior to the expiration of this License, Licensee shall either apply for another license for an Installation or other structure or facility at the subject location or inform the City of its plans to remove its Equipment and bring the public way and any City structure back to its original condition prior to installation of the Approved Wireless Facility.

26. Default.

Any default or failure, as determined exclusively by the City, of the Licensee with regard to any term of this License Agreement hereunder, or the application process or policy, including but not limited to any requirement to procure insurance or pay any fees, or comply with the annual re-certification and affidavit required in the application policy, shall constitute a default and authorize the City to immediately terminate this License Agreement with or without notice, and subject Licensee to any damages claimed by the City arising from such default, in an amount to be exclusively determined by the City, and allow the City to immediately remove any Equipment and dispose of such Equipment as determined necessary by the City, at its sole discretion, and restore the public way, with the City's expenses, including attorneys' fees and costs, to be paid by the Licensee based upon the City's determination, with the provisions of Section 15 hereto being applicable with respect to any such removal and restoration.

27. Late Payments.

Any late payments for any fees or other amounts required by this License Agreement, application fees, permit fees, or otherwise, shall be subject to late fees which shall accrue interest on late payments in the amount of 14 percent per annum. Any such late payments may, in the City's discretion, be considered a default as provided in Section 26 herein.

28. Safety Training.

Upon request of the City to the Licensee, Licensee shall provide to the City's employees who may come in contact with or have access to the Approved Wireless Facility, training that shall include occupational safety training in accordance with applicable laws and Licensee's own policies. Licensee may work collectively with other licensees to provide combined safety training programs to the City's employees. The frequency, scheduling, duration and content of the safety training under this Section shall be determined by the City in cooperation with the Licensee and/or other licensees.

29. Interpretation of Agreement.

This License Agreement has been negotiated at arm's length and between persons and entities sophisticated and knowledgeable in the matters concerned herein and shall be interpreted to achieve the intents and purposes of the parties, without any interpretation against any party responsible for drafting any part of this License Agreement, which shall be considered drafted by all parties hereto.

30. No Estate Created.

This License Agreement shall not be construed as creating or vesting in Licensee any estate in the location of and about the Approved Wireless Facility or any interest in real property.

31. Repair of Damage.

Licensee shall neither cause nor suffer any waste of the location of the Approved Wireless Facility and shall maintain the location of the Approved Wireless Facility in good order at all times. The Licensee's responsibilities shall include the restoration or repair of any and all damage to the location of and about the Approved Wireless Facility resulting from any act, failure to act or negligence of the Licensee. Any time in which any street light or traffic signal, or other structure is not functioning or is damaged, or the public way is not brought back to its original condition, due to any removal or restoration, Licensee shall compensate the City pursuant to the liquidated damages provisions contained herein, in addition to all other expenses required to be borne by the City in any required repair or replacement of the public way or any City structure. This obligation shall survive the termination of the License Agreement.

32. Miscellaneous.

As required by M.G.L. Chapter 62C, Section 49A, the undersigned Licensee certifies under penalty of perjury that he has complied with all laws of the Commonwealth of Massachusetts relating to taxes, reporting of employees and contractors, and withholding and remitting child support, and shall comply with the City of Cambridge's Living Wage Ordinance.

IN WITNESS WHEREOF, the parties hereto have executed this Agreement under seal this ___ day of _____, 20__.

LICENSEE:

By: _____
Print Name: _____
Title: _____

Any Parent Company of Licensee

Company Name

By: _____
Print Name: _____
Title: _____

CITY OF CAMBRIDGE, MASSACHUSETTS

By: _____
Name: Louis A. DePasquale
Title: City Manager

Approved as to form:

By: _____

Name: Nancy E. Glowa
Title: City Solicitor