

- STUDIO
- 1 BEDROOM APT
- 2 BEDROOM APT
- 3 BEDROOM APT
- TERRACE, BALCONY

UNIT TYPE	FLOOR	FLOOR				
		2nd	3rd	4th	5th	6th
STUDIO						
SA	552 sf	3	3	3		
SB	458 sf				1	1
1 BEDROOM						
1A	775 sf	1	1	1		
1B	782 sf	1	1	1		
1C	760 sf	1	1	1		
1D	765 sf				1	1
1E	781 sf				1	1
1F	609 sf	1	1	1		
1G	629 sf	1	1	1		
2 BEDROOM						
2A	1053 sf	1	1	1		
2B	1032 sf	1	1	1		
2C	961 sf				1	1
2D	1018 sf				1	1
2E	1064 sf				1	1
2F	890 sf				1	1
2G	1052 sf				1	1
3 BEDROOM						
3A	1309 sf	1	1	1		
TOTAL		49 UNITS				
		11 - STUDIOS				
		19 - 1 BEDROOM UNITS				
		16 - 2 BEDROOM UNITS				
		3 - 3 BEDROOM UNITS				





- STUDIO
- 1 BEDROOM APT
- 2 BEDROOM APT
- 3 BEDROOM APT
- TERRACE, BALCONY



UNIT TYPE	FLOOR				
	2nd	3rd	4th	5th	6th
STUDIO					
SA	552 sf	3	3	3	
SB	458 sf			1	1
1 BEDROOM					
1A	775 sf	1	1	1	
1B	782 sf	1	1	1	
1C	760 sf	1	1	1	
1D	765 sf				1 1
1E	781 sf				1 1
1F	609 sf	1	1	1	
1G	629 sf	1	1	1	
2 BEDROOM					
2A	1053 sf	1	1	1	
2B	1032 sf	1	1	1	
2C	961 sf				1 1
2D	1018 sf				1 1
2E	1064 sf				1 1
2F	890 sf				1 1
2G	1052 sf				1 1
3 BEDROOM					
3A	1309 sf	1	1	1	
TOTAL		49 UNITS			
		11 - STUDIOS			
		19 - 1 BEDROOM UNITS			
		16 - 2 BEDROOM UNITS			
		3 - 3 BEDROOM UNITS			





- STUDIO
- 1 BEDROOM APT
- 2 BEDROOM APT
- 3 BEDROOM APT
- TERRACE, BALCONY

UNIT TYPE	FLOOR	FLOOR				
		2nd	3rd	4th	5th	6th
STUDIO						
SA	552 sf	3	3	3		
SB	458 sf				1	1
1 BEDROOM						
1A	775 sf	1	1	1		
1B	782 sf	1	1	1		
1C	760 sf	1	1	1		
1D	765 sf				1	1
1E	781 sf				1	1
1F	609 sf	1	1	1		
1G	629 sf	1	1	1		
2 BEDROOM						
2A	1053 sf	1	1	1		
2B	1032 sf	1	1	1		
2C	961 sf				1	1
2D	1018 sf				1	1
2E	1064 sf				1	1
2F	890 sf				1	1
2G	1052 sf				1	1
3 BEDROOM						
3A	1309 sf	1	1	1		
TOTAL		49 UNITS				
		11 - STUDIOS				
		19 - 1 BEDROOM UNITS				
		16 - 2 BEDROOM UNITS				
		3 - 3 BEDROOM UNITS				

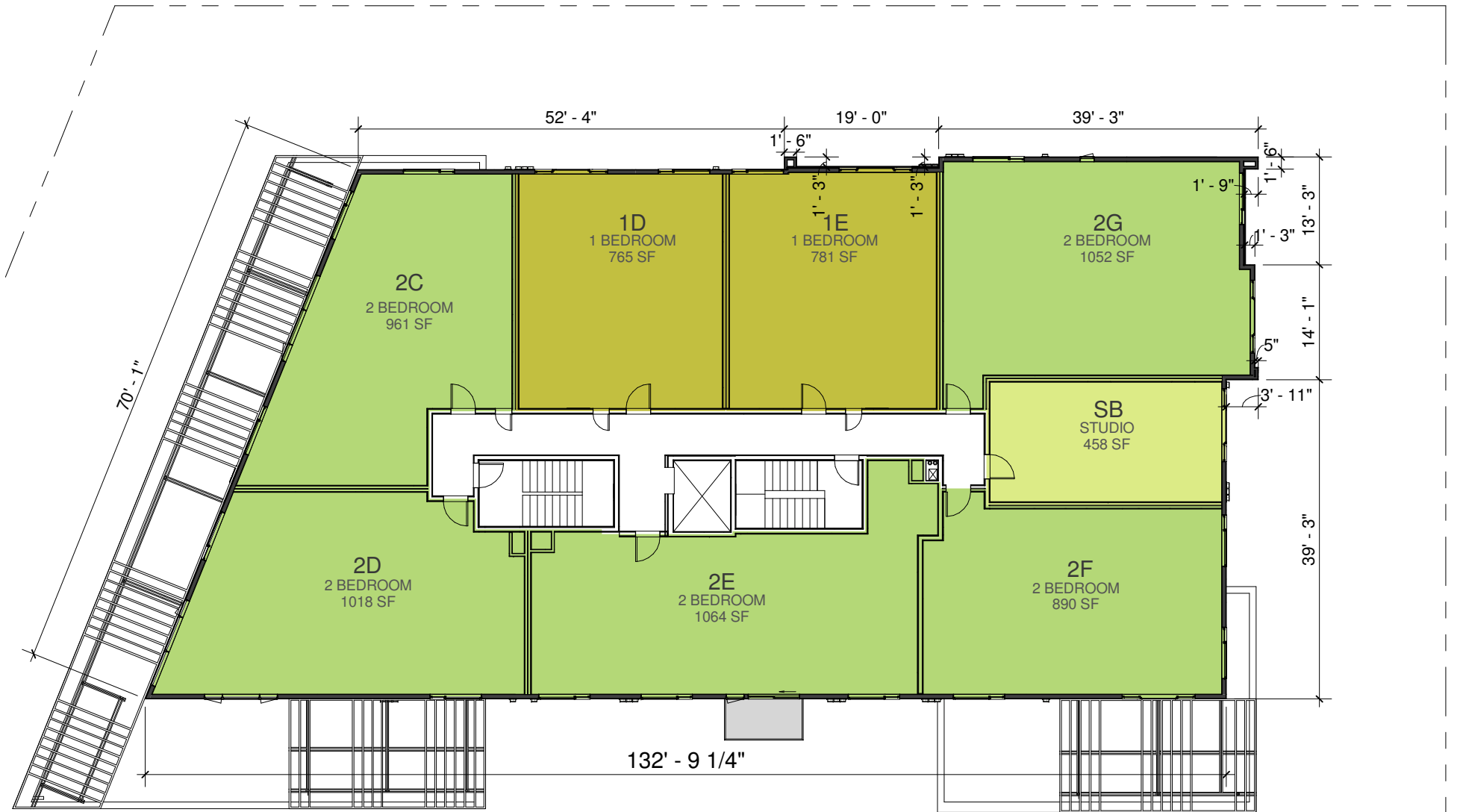

KEY

LT-01	RECESSED DOWNLIGHT LED
LT-02	ARM MOUNTED SCONCE DOWNLIGHT
LT-03	BOLLARD PATH LIGHT
LT-04	TREE LIGHT
LT-05	GARDEN POST MTD LIGHT
LT-06	RECESSED LED SIGN LIGHT
LT-07	EXTERIOR WALL MOUNTED LED SCONCE



LT-01



LT-02



LT-05



LT-06



LT-03



LT-04



LT-07

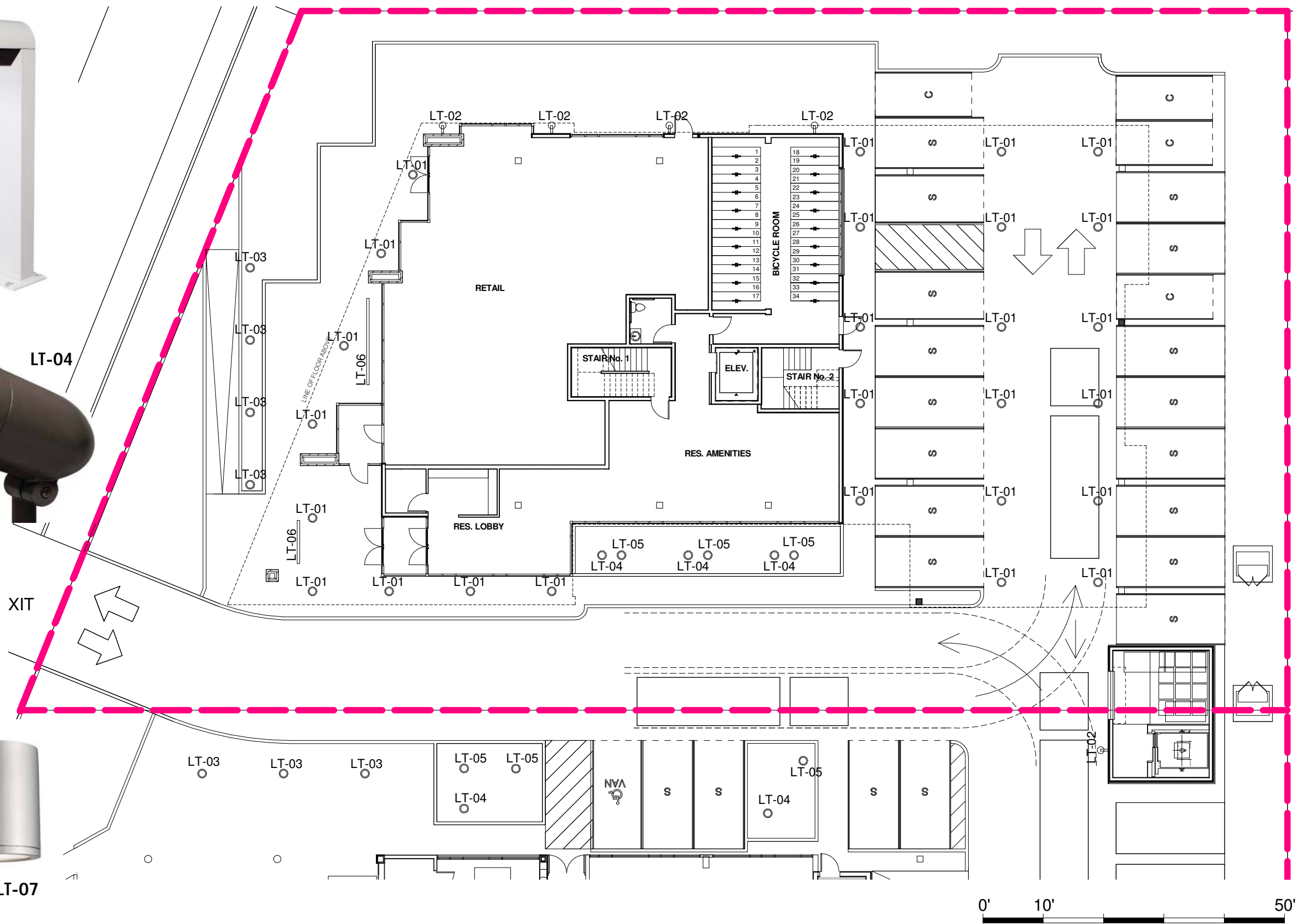

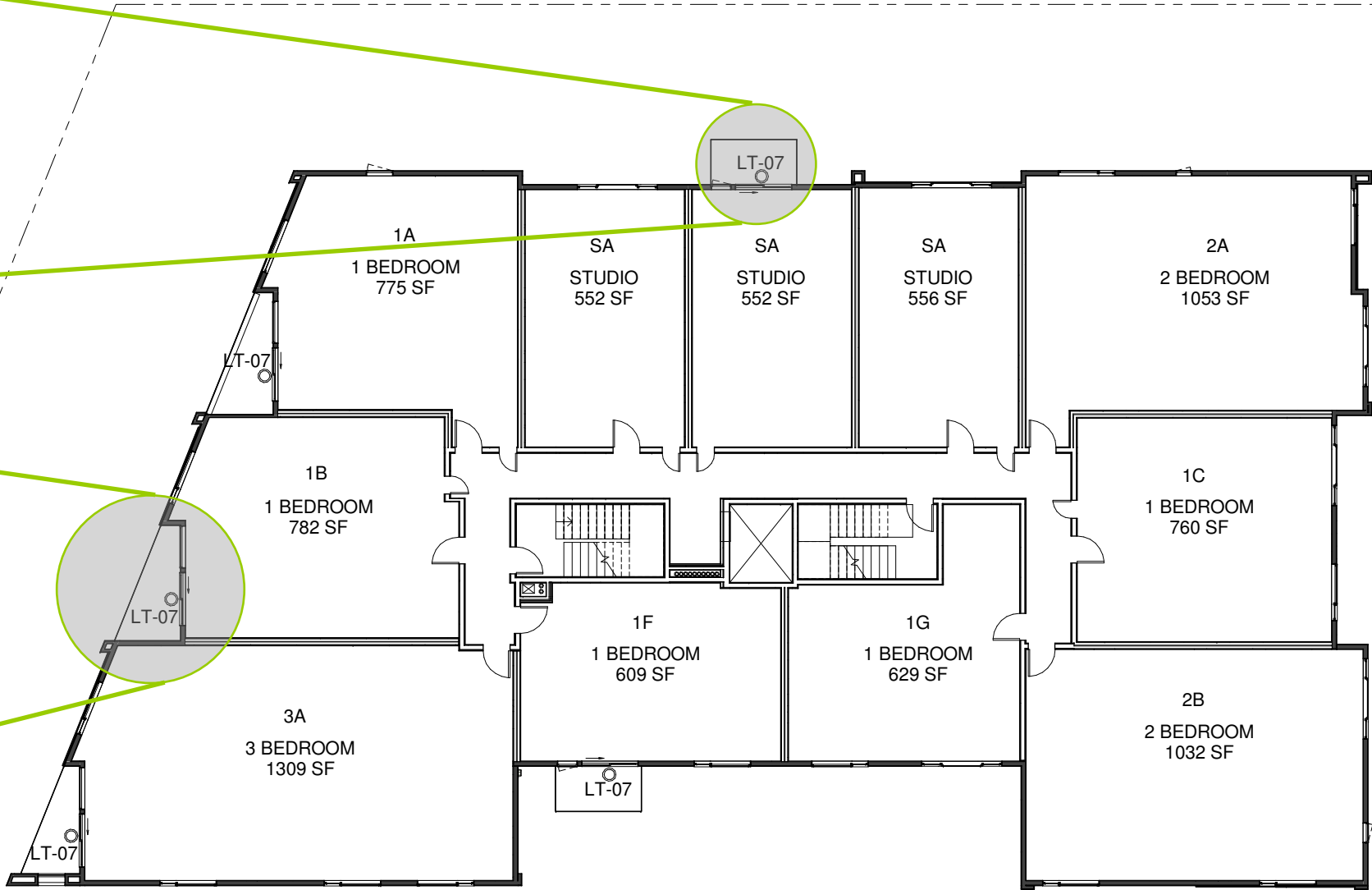
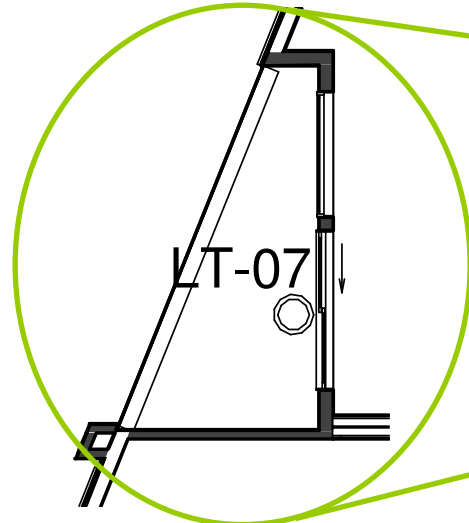
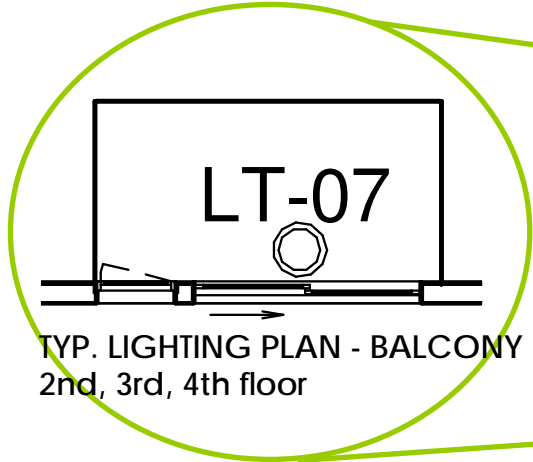

KEY

LT-01	RECESSED DOWNLIGHT LED
LT-02	ARM MOUNTED SCONCE DOWNLIGHT
LT-03	BOLLARD PATH LIGHT
LT-04	TREE LIGHT
LT-05	GARDEN POST MTD LIGHT
LT-06	RECESSED LED SIGN LIGHT
LT-07	EXTERIOR WALL MOUNTED LED SCONCE



605 CONCORD AVE. CAMBRIDGE
 SPECIAL PERMIT APPLICATION
 SEPTEMBER 6 2016



KEY

LT-01	RECESSED DOWNLIGHT LED
LT-02	ARM MOUNTED SCONCE DOWNLIGHT
LT-03	BOLLARD PATH LIGHT
LT-04	TREE LIGHT
LT-05	GARDEN POST MTD LIGHT
LT-06	RECESSED LED SIGN LIGHT
LT-07	EXTERIOR WALL MOUNTED LED SCONCE

