

An aerial photograph of Harvard Square in Cambridge, Massachusetts. The square is paved with red bricks and features a large, modern bus stop with a green roof in the center. Several yellow taxis and other cars are visible on the surrounding streets. People are walking and sitting on a stone ledge in the foreground. In the background, there are brick buildings and a tall, thin tower. The sky is blue with some light clouds.

HARVARD SQUARE KIOSK & PLAZA

Community Meeting April 25, 2018

WHAT IS PLACEMAKING?

When people collectively and deliberately shape their public spaces to facilitate social interaction and improve their community's quality of life.

WHAT MAKES A GREAT PLACE?



WHAT WE HEARD



COMMUNITY ENGAGEMENT

- Harvard Square Kiosk Working Group Meetings
- Informational Operations Interviews
- Pop-Up Workshops On-Site
- Community Survey
- Community Workshops
- Call for Ideas

WORKING GROUP:

The qualities and feeling of the Kiosk and Plaza

- Flexible and adaptable – across seasons, different times of day, month, or year
- Welcoming and safe for all users
- A community gathering space
- Navigable – maintaining the space as a busy transit thoroughfare
- Dynamic and engaging
- “Increase the JOY of being in Harvard Square for all types of people” John Shapiro

INFORMATIONAL OPERATIONS INTERVIEWS

Cambridge Arts Council
Cambridge City Manager
Cambridge Historical Commission
Cambridge Office for Tourism
Cambridge Police Department
Cambridge Department of Human
Service Program
Cambridge Department of Public
Works
First Parish Church
Halvorson Design
Harvard Square Business Association
Harvard Square Neighborhood
Association
Harvard University
MBTA
Y2Y Harvard Square



Pop Up Workshop

Site Visit and Place Game



CALL FOR IDEAS

Harvard Square Kiosk and Adjacent Kiosk Plaza as Multivalent News Center

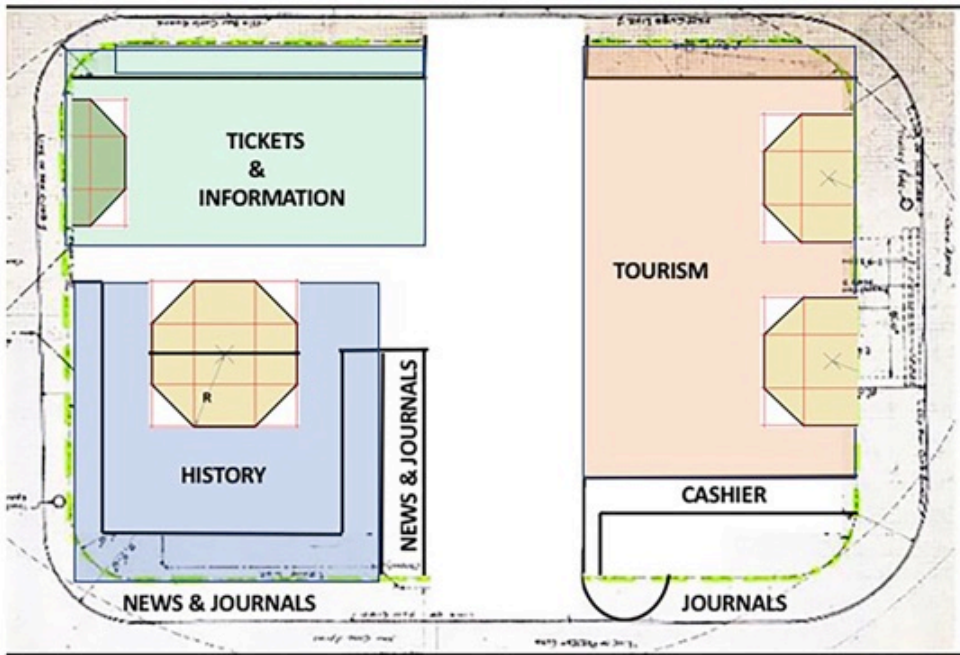

Harvard Square Kiosk as Welcome Center: Plan using OTN-Cabinets

Less is More



Plaza Circulation, Shade, Light, and Interaction



Transparent LCD Displays

Kiosk as Art Space



CALL FOR IDEAS: RANKING

QUESTION 1:
OVERALL IDEA

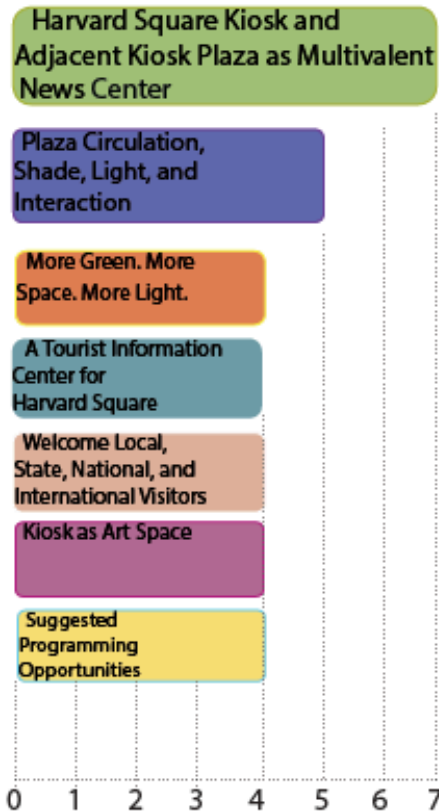

QUESTION 2:
KIOSK IDEA

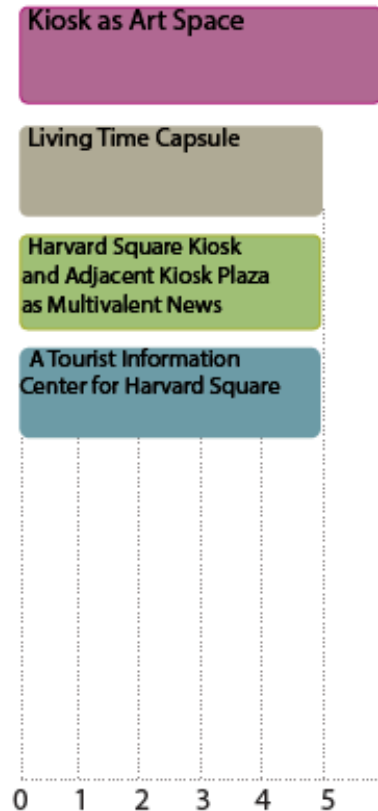

QUESTION 3:
PROGRAMMING IDEA



QUESTION 4:
PHYSICAL IMPROVEMENTS
AND AMENITIES IDEAS

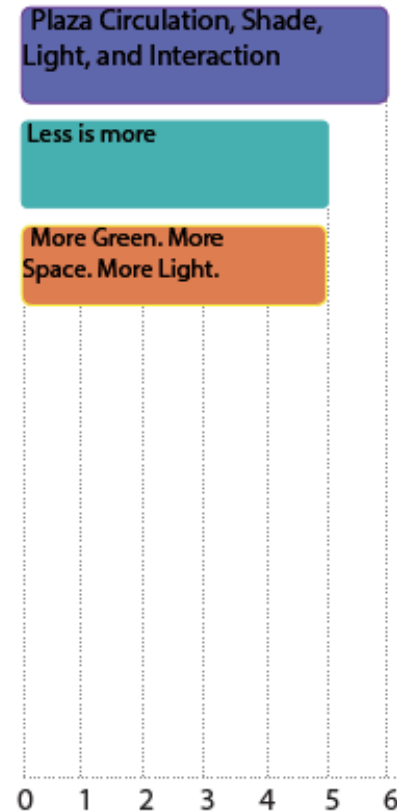

VOTES

CALL FOR IDEAS: USERS

CURRENT USERS

COMMUTERS

RESIDENTS

INTERNATIONAL VISITORS

DOMESTIC TOURISTS

UNIVERSITY STUDENTS

HOMELESS

PEOPLE SEEKING INFORMATION

PEOPLE SEEKING NEWS

CHESS PLAYERS

PEDESTRIANS PASSING THROUGH

PEOPLE SEEKING DIRECTIONS

PEOPLE SEEKING HARVARD
MEMORABILIA

PEOPLE SEEKING SNACKS

TOUR GROUPS

PEOPLE WATCHING ENTERTAINMENT

BUSKERS

VENDORS

LOCAL BUSINESSES

LOCAL WORKERS

PEOPLE SEEKING RESTROOMS

FUTURE USERS

PEOPLE SEEKING KNOWLEDGE:
history, books

PEOPLE READING NEWS
HOMELESS SEEKING
INFORMATION

PEOPLE COMING TO EXCHANGE
IDEAS

PEOPLE ATTENDING
PERFORMANCES

SHOPPERS

COOKING STUDENTS

LOCAL BUSINESS OWNERS

CHILDREN SCHOOL CLASSES

CHILDREN & FAMILIES

CALL FOR IDEAS: USES/AMENITIES

KIOSK USES

Visitors' Center

News-past, present, future, digital & print

Cambridge information and events

History/Living Time Capsule

Cambridge history micro-museum

Café

Art exhibits/celebrations

Multi-use pop-ups with local business involvement

Community service hub

R&D science & innovation showcase

Teasers for nearby venues

Florist shop

Place for discourse

PLAZA USES

Sitting

Eating

Performance space

Free speech space

Speaker programs

Art installations/Sculpture garden

Tour group gathering

Cell phone charging

Food vending

Retail or arts/crafts vending

Seasonal thematic programming or related to local events

Garden

Quiet contemplation

Water feature

Bonfires

Thematic programming related to history

PROGRAMMING IDEAS



KIOSK PROGRAMMING

VISITOR'S CENTER



NEWS AND INFORMATION



HISTORIC EXHIBITS

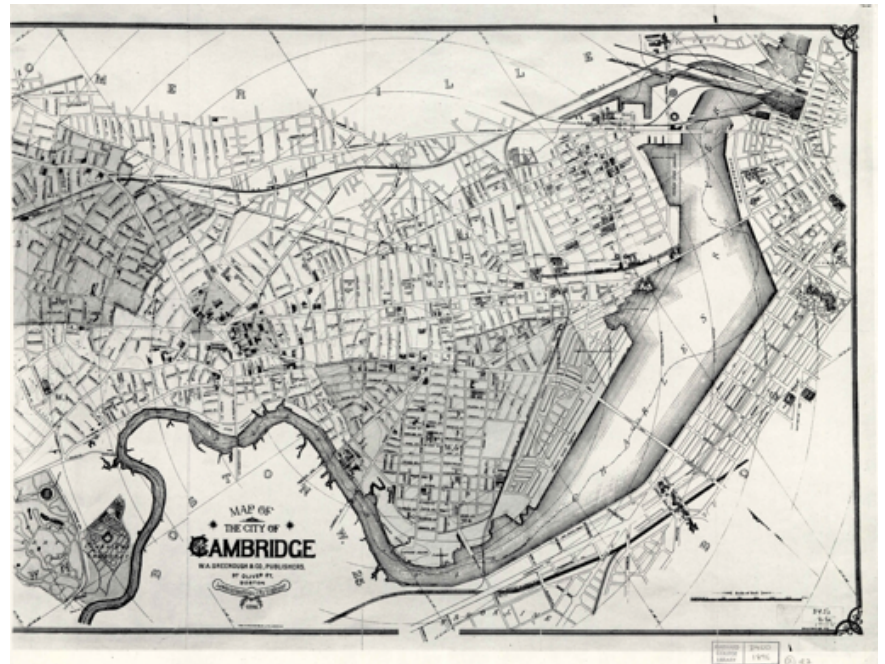

COMMUNAL TABLE



PERFORMANCE SPACE



TICKET SALES



FOOD KIOSK/CAFE



KIOSK AS OPEN & FLEXIBLE SPACE

PLAZA PROGRAMMING



A PLACE TO MEET



Harvard Square Kiosk 1970's



A PLACE TO SHARE INFORMATION



A PLACE FOR PROTEST



ACTIVITIES FOR EVERYONE



PERFORMANCES



GAMES



OUTDOOR ART EXHIBITS



VENDORS



MICRO MARKETS



AMENITIES: SEATING



AMENITIES: PLANTINGS



AMENITIES: LIGHTING



PLAZA: FLEXIBLE OUTDOOR ROOMS

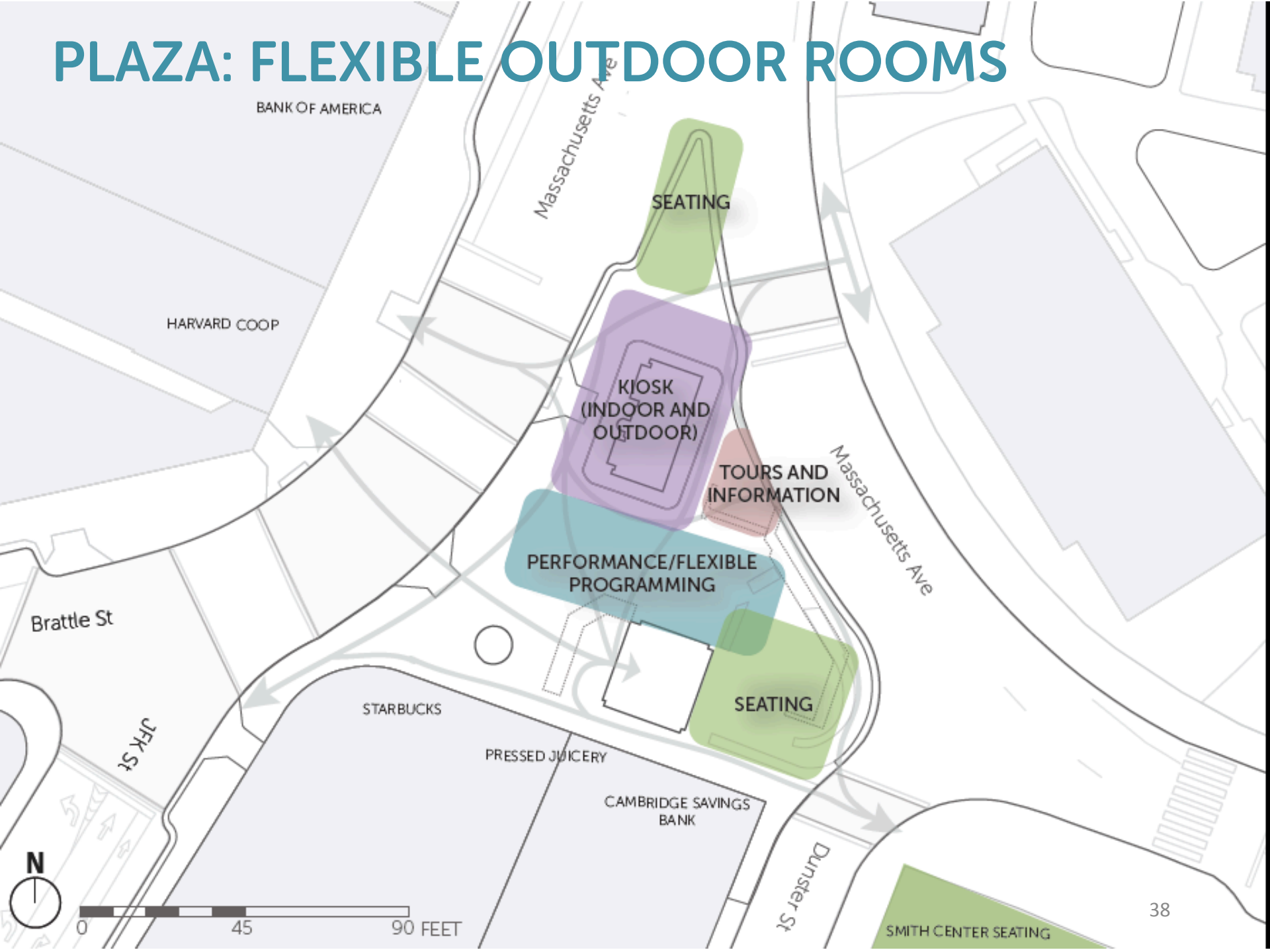

MANAGEMENT AND OPERATIONS



HOW DOES IT HAPPEN?

Management Tasks

- Site maintenance, security, and cleaning
- Onsite staffing (overseeing daily uses, execution of programming)
- Offsite management (programming and scheduling, promotion, financial management)



HOW DOES IT HAPPEN?

Revenue Streams

- Ticket sales (walking tours and other local events)
- Pop-up vendor sales
- Sponsorship of ongoing events and programming (e.g. River Festival)
- Advertising (appropriately scaled)
- Promotions



HOW DOES IT HAPPEN?

Governance Process

- The City hires an Operator to oversee Kiosk operations and programming in the Plaza
- An Advisory Committee appointed by City Manager provides ongoing recommendations about Kiosk and Plaza operations



HARVARD SQUARE PLAZA PUBLIC MEETING 4.25.18

DESIGN CONSIDERATIONS

CONTEXT

- ENHANCE CONNECTIONS TO SURROUNDING USES

CIRCULATION

- PRESERVE PRIMARY CIRCULATION ROUTES
- MAKE BETTER USE OF REMAINING SPACE ON THE PLAZA

FLEXIBLE SPACE

- DECLUTTER - REMOVE WALLS/STEPS/PLANTERS/INFO BOOTH
- LEVEL/FLAT PLAZA - UNIVERSAL ACCESS
- MINIMIZE PERMANENT FURNISHINGS - MOVABLE FURNITURE

SENSE OF ENCLOSURE / SAFETY / COMFORT

- PROTECTION FROM VEHICLES
- SHADE - TREES OR UMBRELLAS

PLANTING

- TREES
- PLANTERS

PROGRAMMING

- ACCOMODATE VARIETY OF USES: EVENTS, PASSIVE, ART, MUSIC, FOOD, ETC
- NIGHT/DAY
- SEASONALITY



NEIGHBORHOOD HUB

 BOUNDARY

HARVARD SQUARE IS THE EPICENTER
FOR 5 SURROUNDING COMMUNITIES

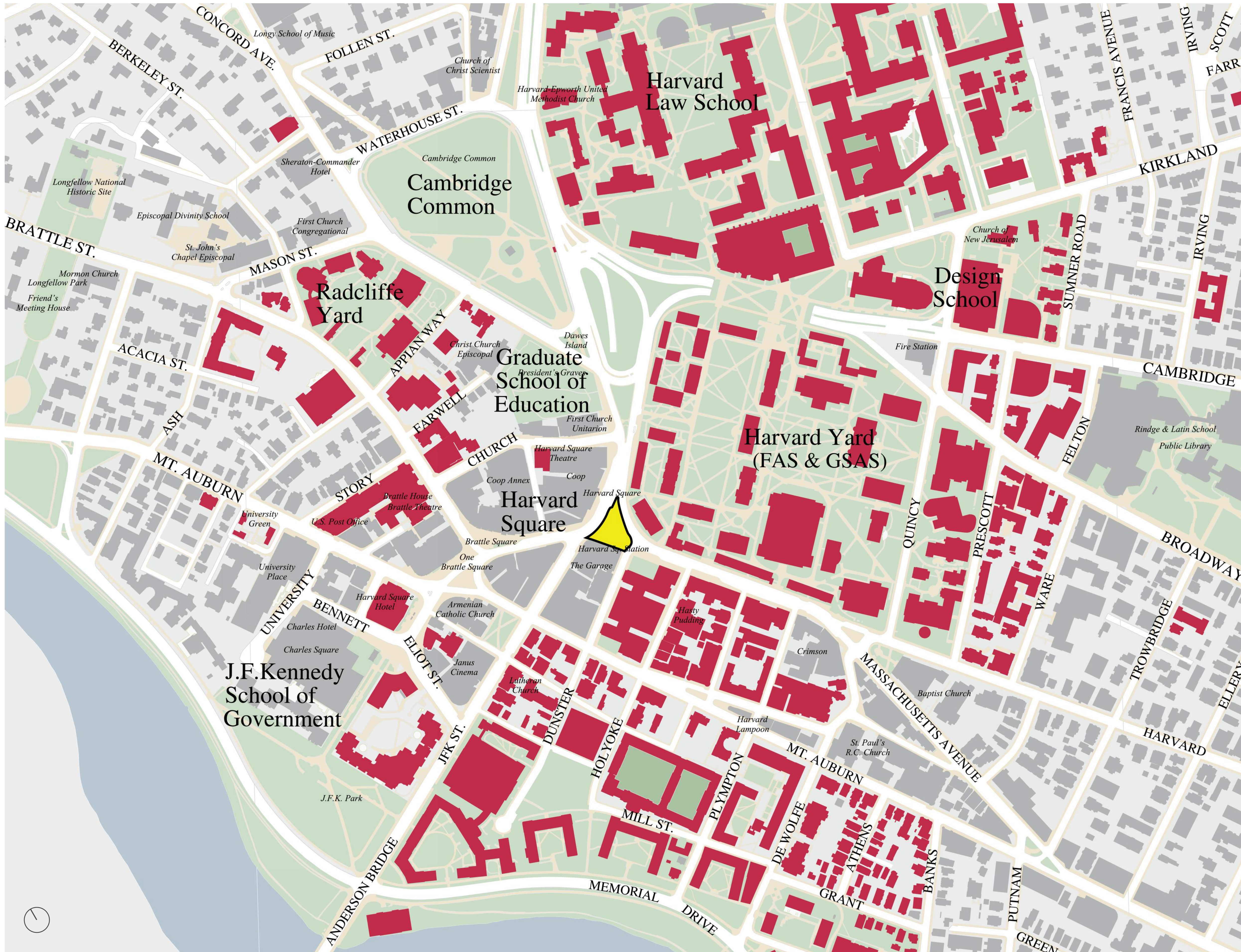

CAMPUS HUB

HARVARD AND AFFILIATED BUILDINGS

HARVARD SQUARE IS THE EPICENTER FOR HARVARD UNIVERSITY

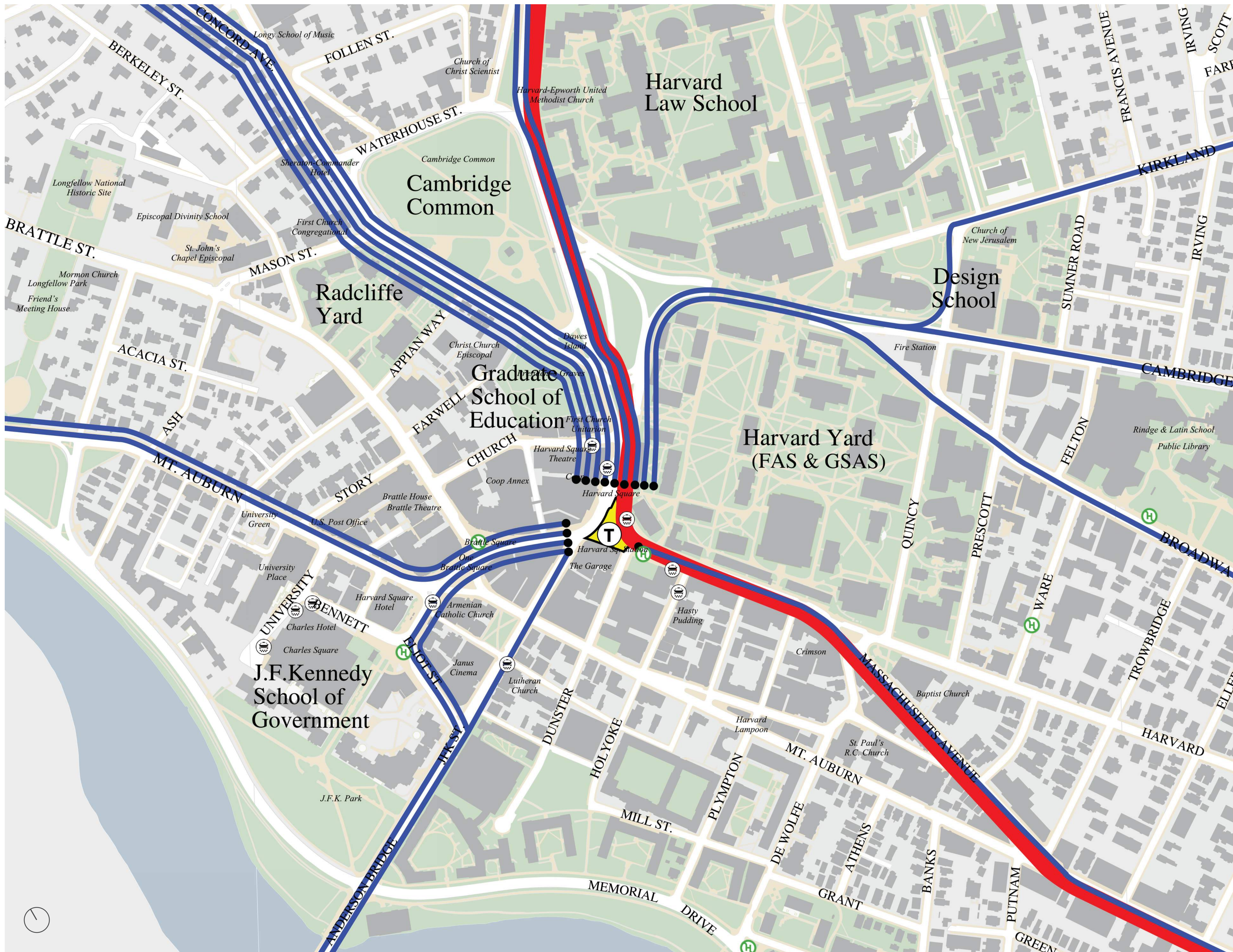

TRANSPORTATION HUB

- █ MBTA RED LINE
- █ BUS ROUTES
- T MBTA STATION
- T TAXI STAND
- H HUBWAY STATION



Smith Center

Harvard University

Brattle Square

First Parish Church

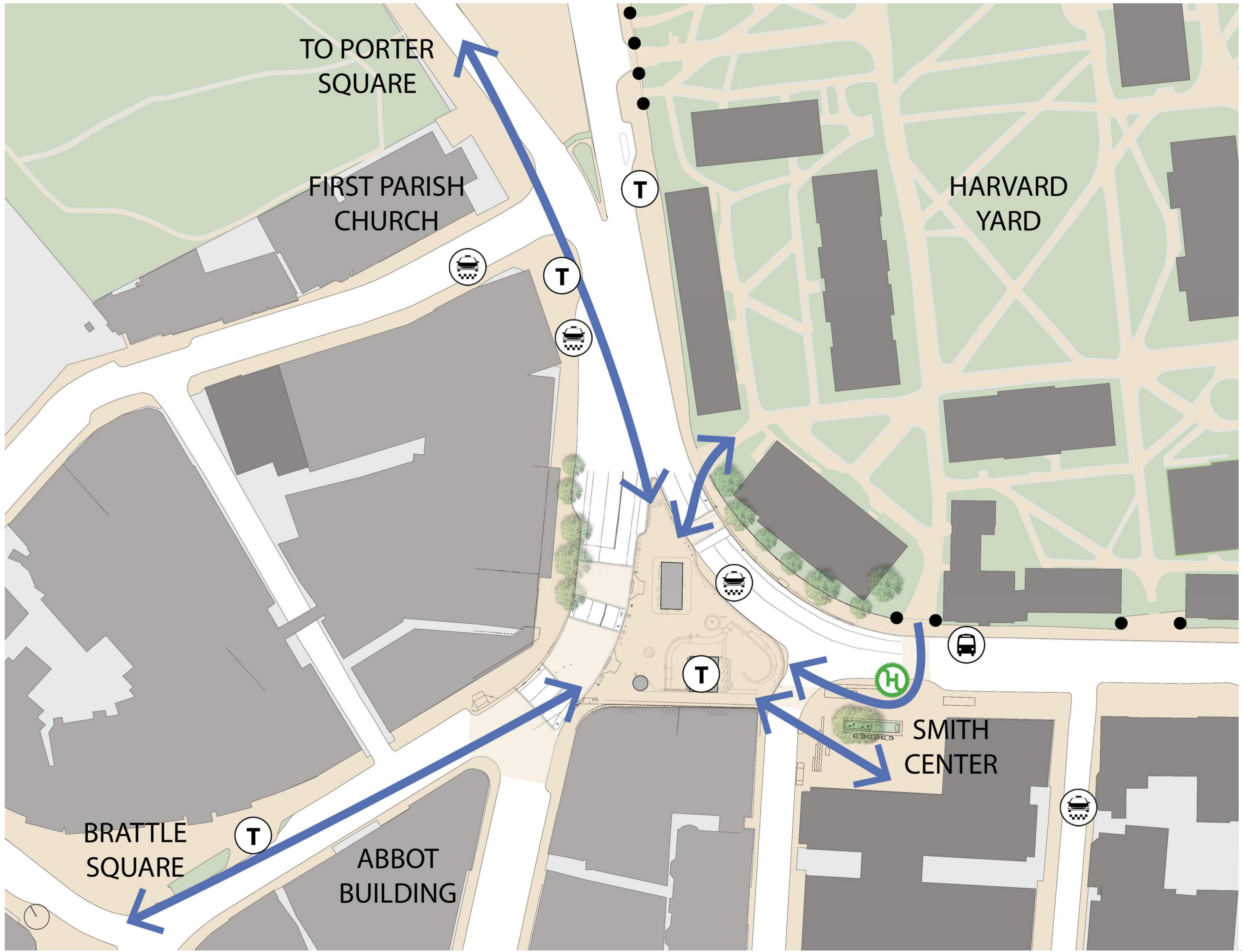

CONNECTIVITY DIAGRAM

- PEDESTRIAN CIRCULATION
- T MBTA STATION
- TAXI STAND
- H HUBWAY STATION





BUFFERING THE SPACE FROM MASS AVE WOULD RESULT IN SAFER & MORE COMFORTABLE GATHERING



STEPS AND RETAINING WALLS WILL BE REQUIRED TO ADDRESS THE GRADE CHANGE BETWEEN MASS AVE AND THE PLAZA.



REMOVING A TAXI SPACE COULD AMELIORATE THE CIRCULATION PINCH POINT ADJACENT TO THE KIOSK



LOWERING THE FINISH FLOOR ELEVATION OF THE KIOSK WILL IMPROVE ADA ACCESSIBILITY



CONSIDERATION OF SEASONAL VARIATION AND NIGHTTIME ACTIVATION WILL CONTRIBUTE TO THE SUCCESS OF THE PLAZA

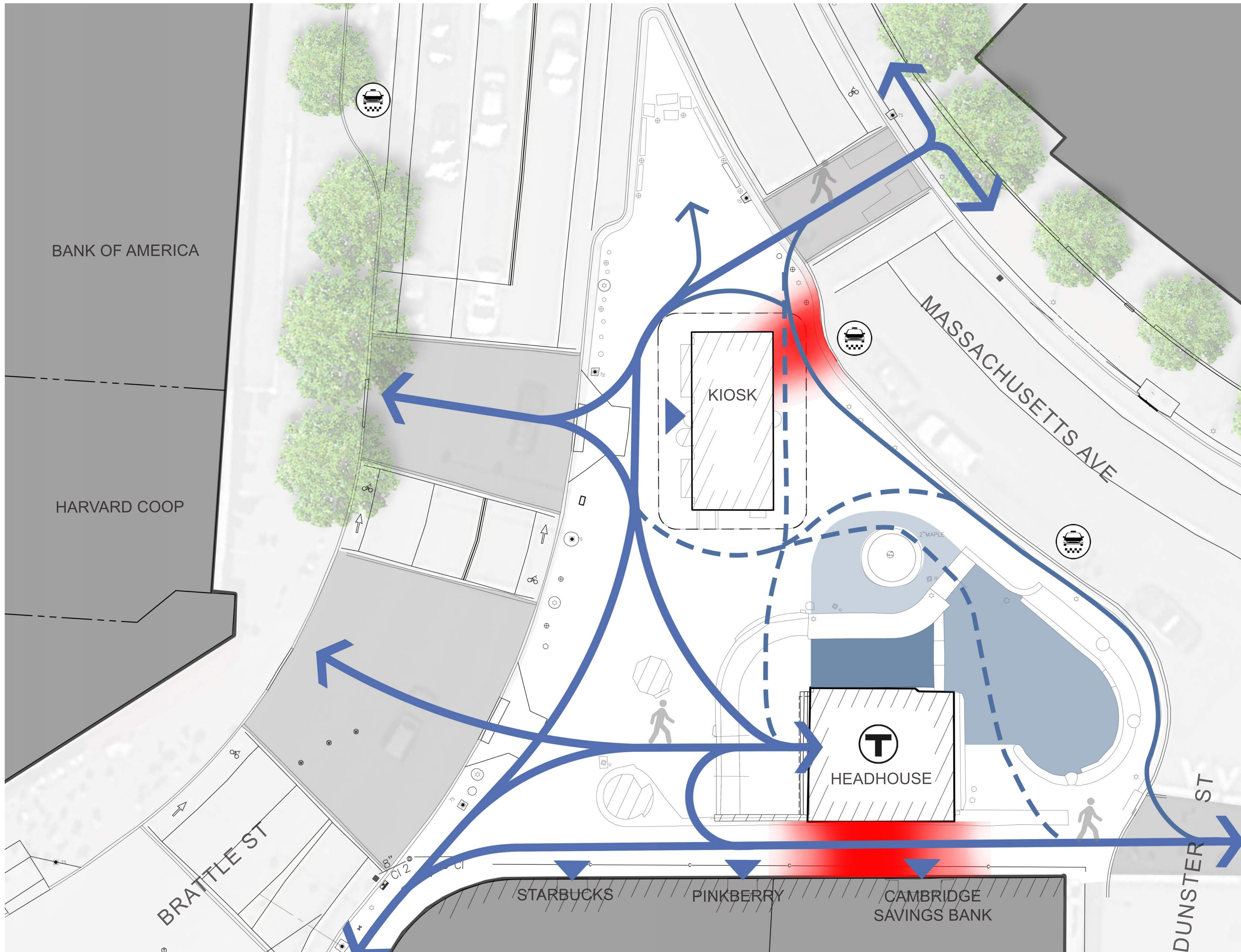

PEDESTRIAN CIRCULATION

- MAJOR
- MINOR
- OCCASIONAL
- PINCH POINT

HEAVY PEDESTRIAN CIRCULATION THROUGHOUT THE PLAZA LIMITS GATHERING OPPORTUNITIES

THE AREA WITH THE LEAST CIRCULATION IS SUBDIVIDED BY WALLS AND STEPS AT THREE DIFFERENT ELEVATIONS

POTENTIAL TO RECONFIGURE THE WALLS AND STEPS, CREATING ONE LARGER, FLEXIBLE SPACE



CIRCULATION DIAGRAM

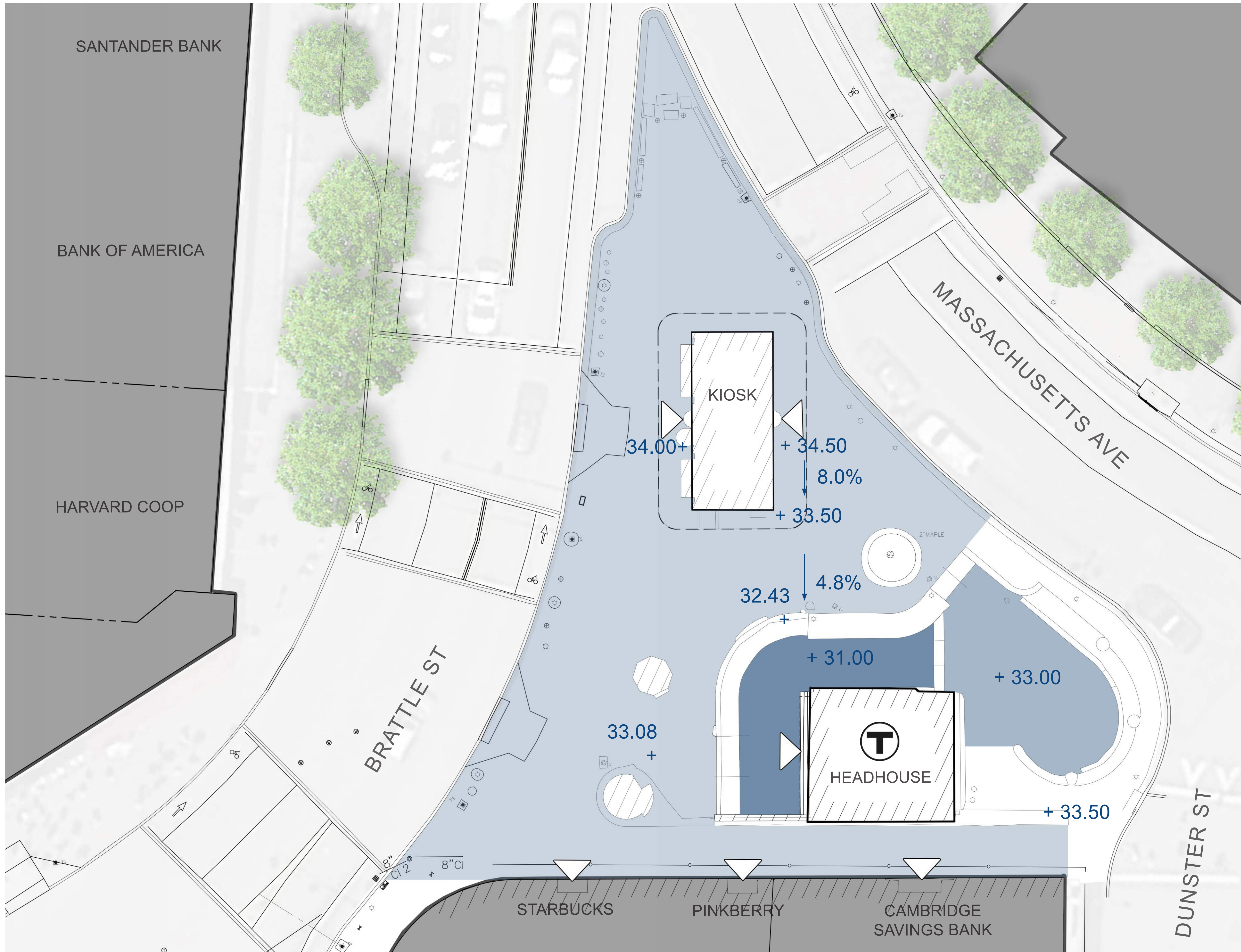

EXISTING ELEVATION

- UPPER
- INTERMEDIATE
- LOWER

PLAZA IS SUBDIVIDED INTO THREE LEVELS LIMITING CIRCULATION AND USAGE

WEST SIDE OF KIOSK IS 6" HIGHER THAN EAST SIDE RESULTING IN A STEP DOWN OUT OF KIOSK

EXISTING PLAZA SLOPES ARE NOT COMPLIANT WITH CURRENT ADA/MAAB REGULATIONS



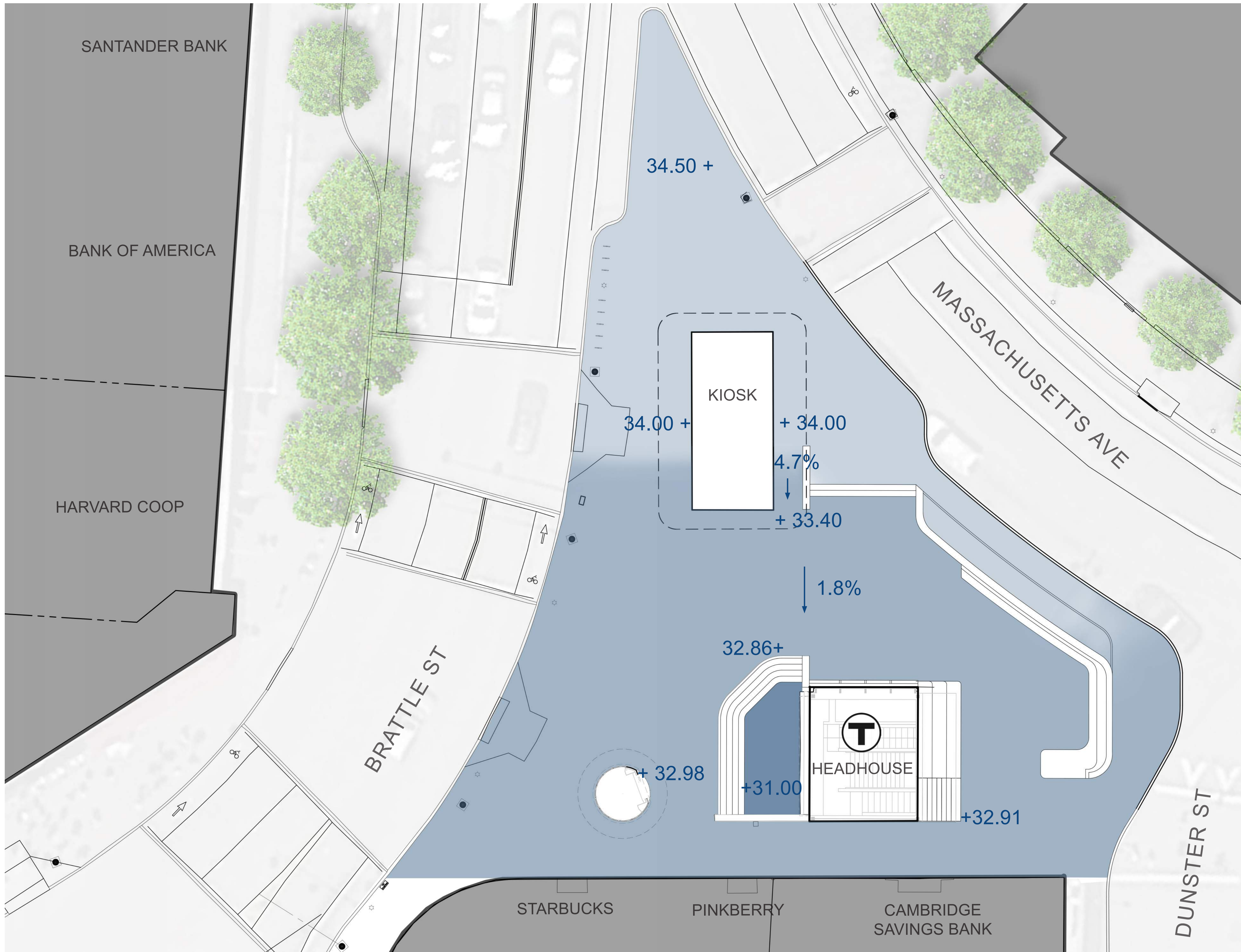

PROPOSED ELEVATION

- UPPER
- INTERMEDIATE
- LOWER

RECONFIGURED STEPS AND WALLS
CREATE ONE LARGER GATHERING
SPACE AT INTERMEDIATE LEVEL

KIOSK ELEVATION IS LOWERED 6"
PROVIDING UNIVERSAL ACCESS TO
BOTH EAST AND WEST ENTRANCES

PLAZA SLOPES ARE COMPLIANT WITH
CURRENT ADA/MAAB REGULATIONS



PROPOSED ELEVATION DIAGRAM

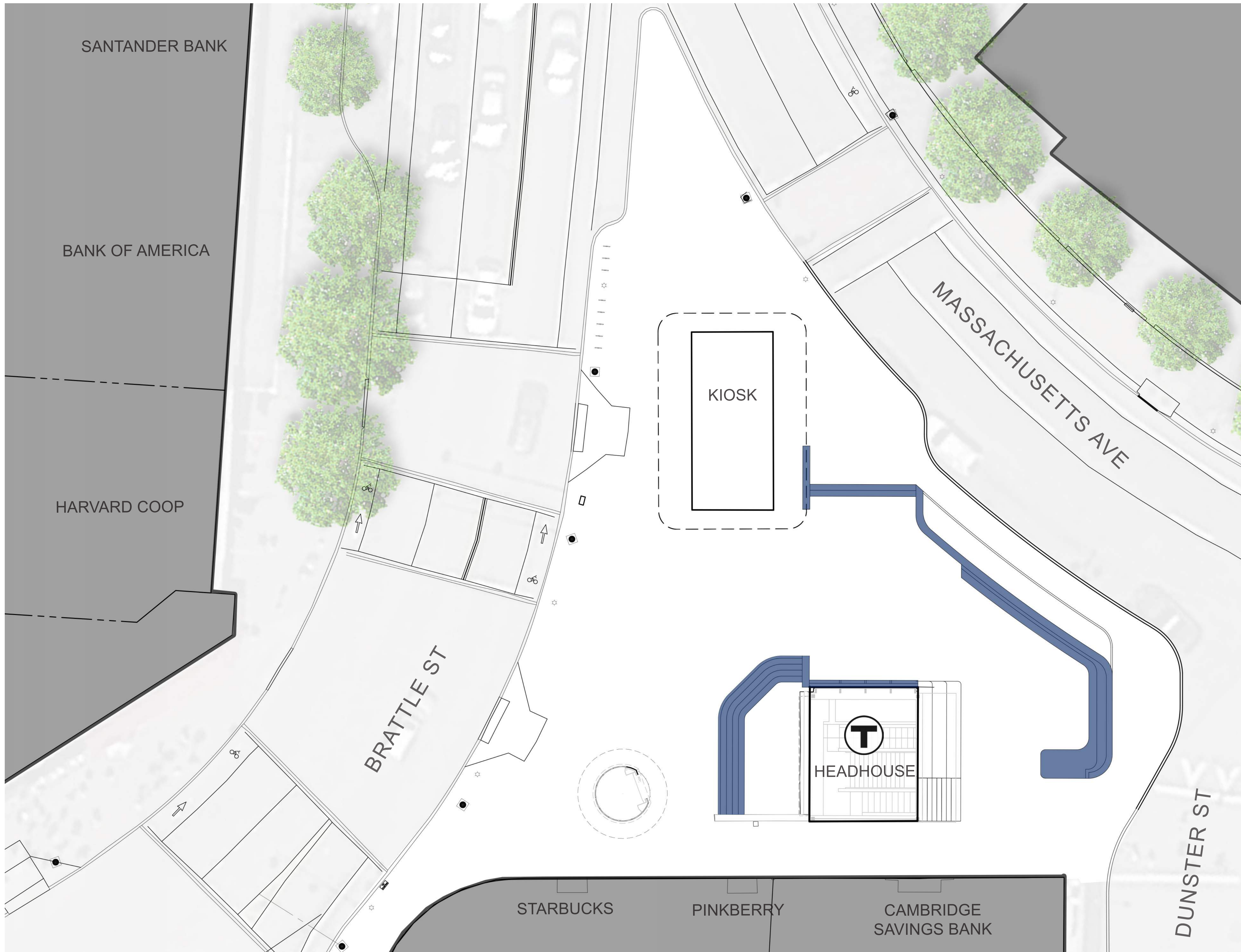

STAIRS AND WALLS

RETAINING WALLS/STEPS

WALL AND STAIRS REQUIRED TO RETAIN HIGHER ELEVATION OF MASS AVE

ADDITIONAL RETAINING WALL REQUIRED TO SEPERATE PLAZA FILL FROM MBTA HEAHOUSE FACADE

RECONFIGURED STEPS AND ADDITIONAL RISER AT HEADHOUSE ENTRANCE



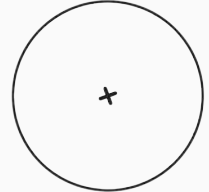
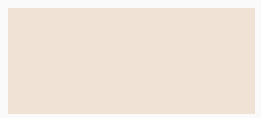

TREE PLANTING AREAS

-  PROPOSED TREE LOCATION
-  ADEQUATE SOIL DEPTH FOR FLUSH STREET TREES

STREET TREES PLANTED IN A FLUSH PERMEABLE PAVING CONDITION REQUIRE APPROX. 4' DEPTH FROM FINISH GRADE TO TOP OF STRUCTURE

PROPOSED TREES WERE LOCATED OUT OF CIRCULATION ROUTES WHERE THEY COULD FRAME VIEWS TO THE KIOSK



ADEQUATE SOIL DEPTH FOR TREE PLANTING

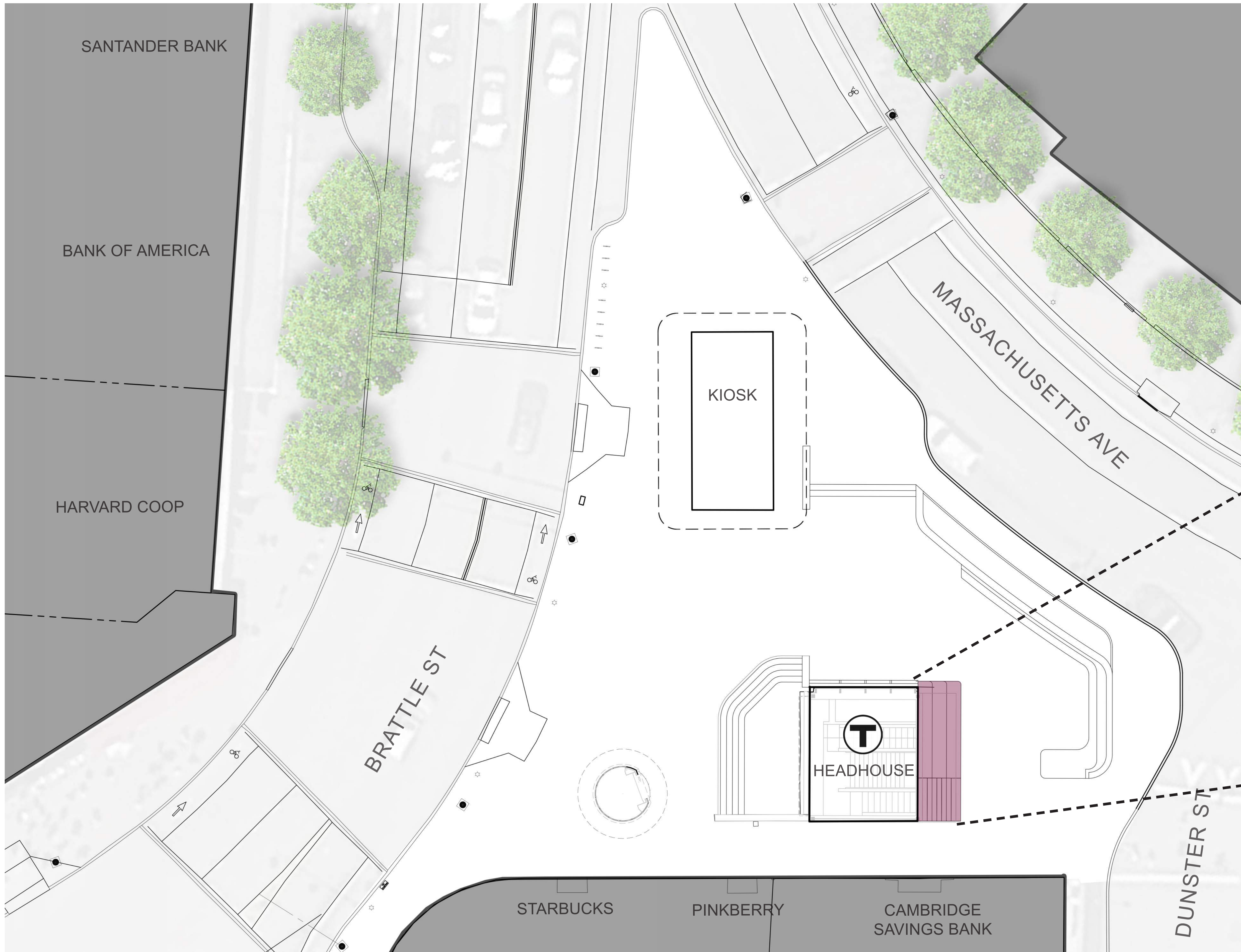

TERRACED SEATING FEATURE

TERRACED SEATING

POTENTIAL FOR A TERRACED SEATING FEATURE OVER THE EXISTING SLOPED BRICK WALL. MUST BE REVIEWED AND APPROVED BY THE MBTA AND DETERMINED STRUCTURALLY FEASIBLE.

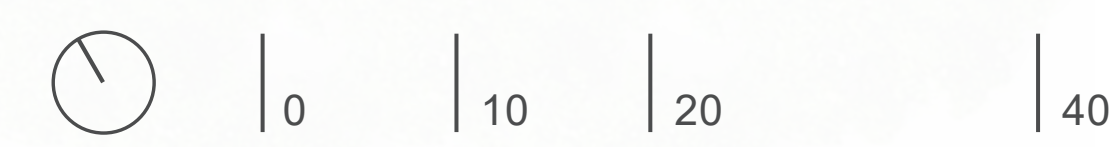

POTENTIAL TERRACED SEATING FEATURE

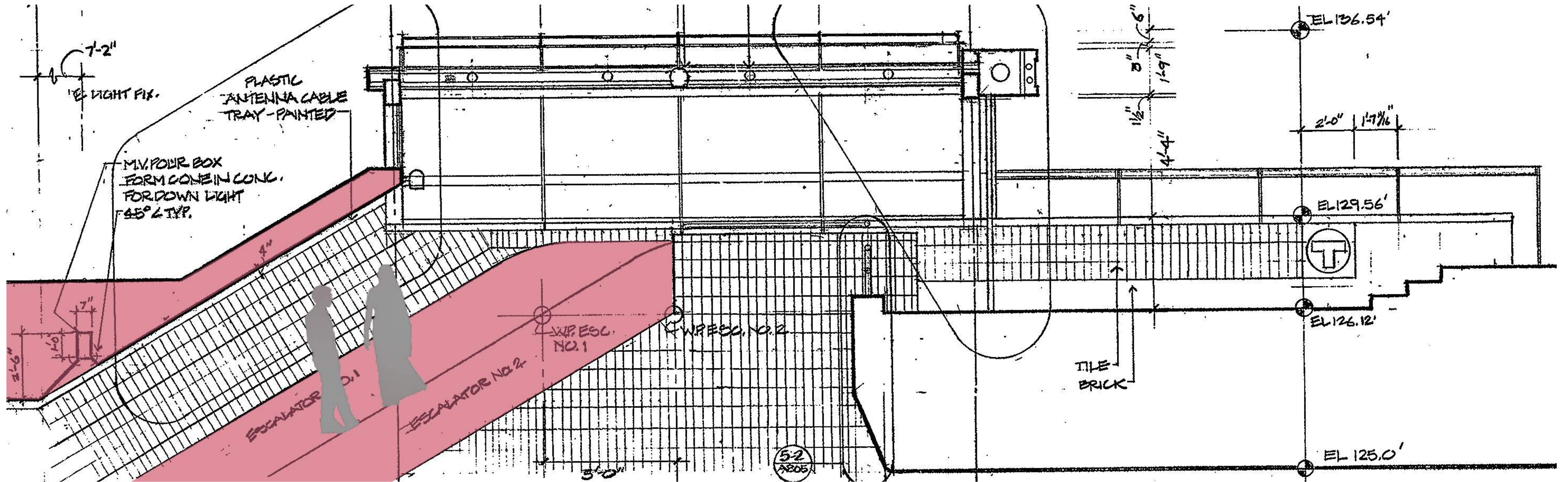
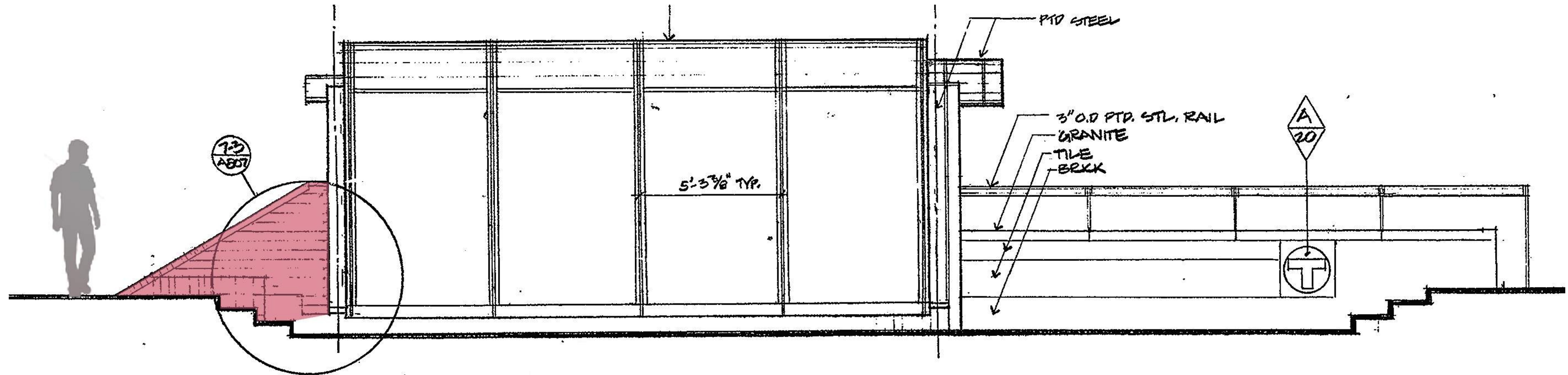

HEADHOUSE EXISTING CONDITIONS - SLOPED BRICK REAR FACADE



CURB LINE MODIFICATIONS

EXPANDED PLAZA AREA

REMOVE ONE TAXI SPACE TO INCREASE PLAZA AREA AROUND KIOSK WHILE MINIMIZING CIRCULATION PINCH POINT

MODIFY CURB LINE TO ACCOMODATE TAXI AT EASTERN EDGE OF PLAZA





ADDITIONAL "GREENING"

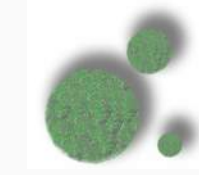

MOVEABLE PLANTERS

PLANTERS ALONG THE PERIMETER SERVE TO BUFFER THE ROADWAY AND DIRECT PEDESTRIAN CIRCULATION

ADDITIONAL PLANTERS CAN BE DEPLOYED THROUGHOUT THE PLAZA ADDING SEASONAL INTEREST

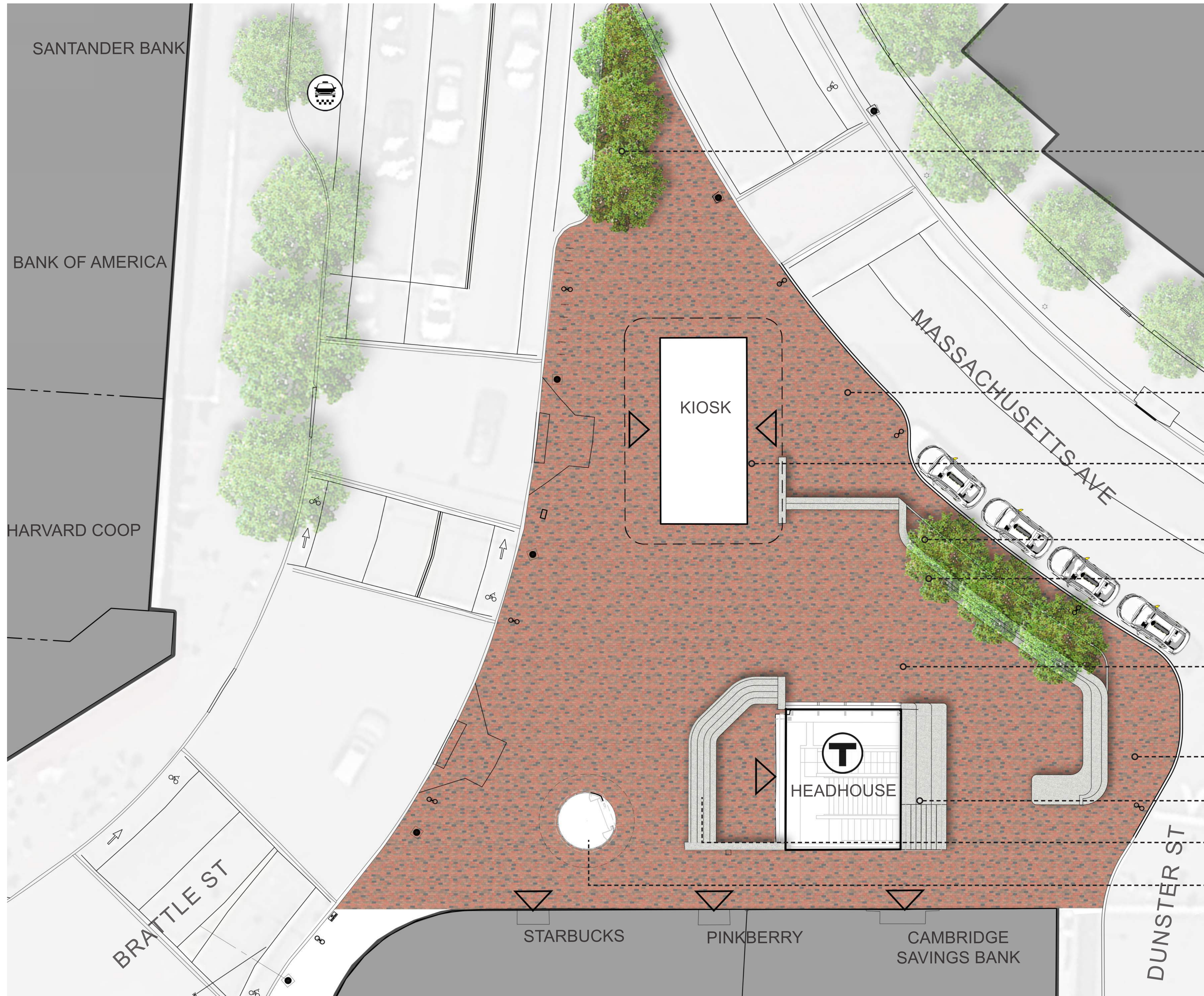

TREES IN PERMEABLE PAVERS

REMOVE ONE TAXI SPACE TO AMELIORATE PINCH POINT

LOWER FINISH GRADE OF KIOSK FOR ACCESSIBILITY

TREES IN PERMEABLE PAVERS

RETAINING SEAT WALL

LEVEL FLEXIBLE PLAZA SPACE

WIDENED SIDEWALK

TERRACED SEATING FEATURE

RECONFIGURED STAIRS

NEW GLASS MBTA ELEVATOR



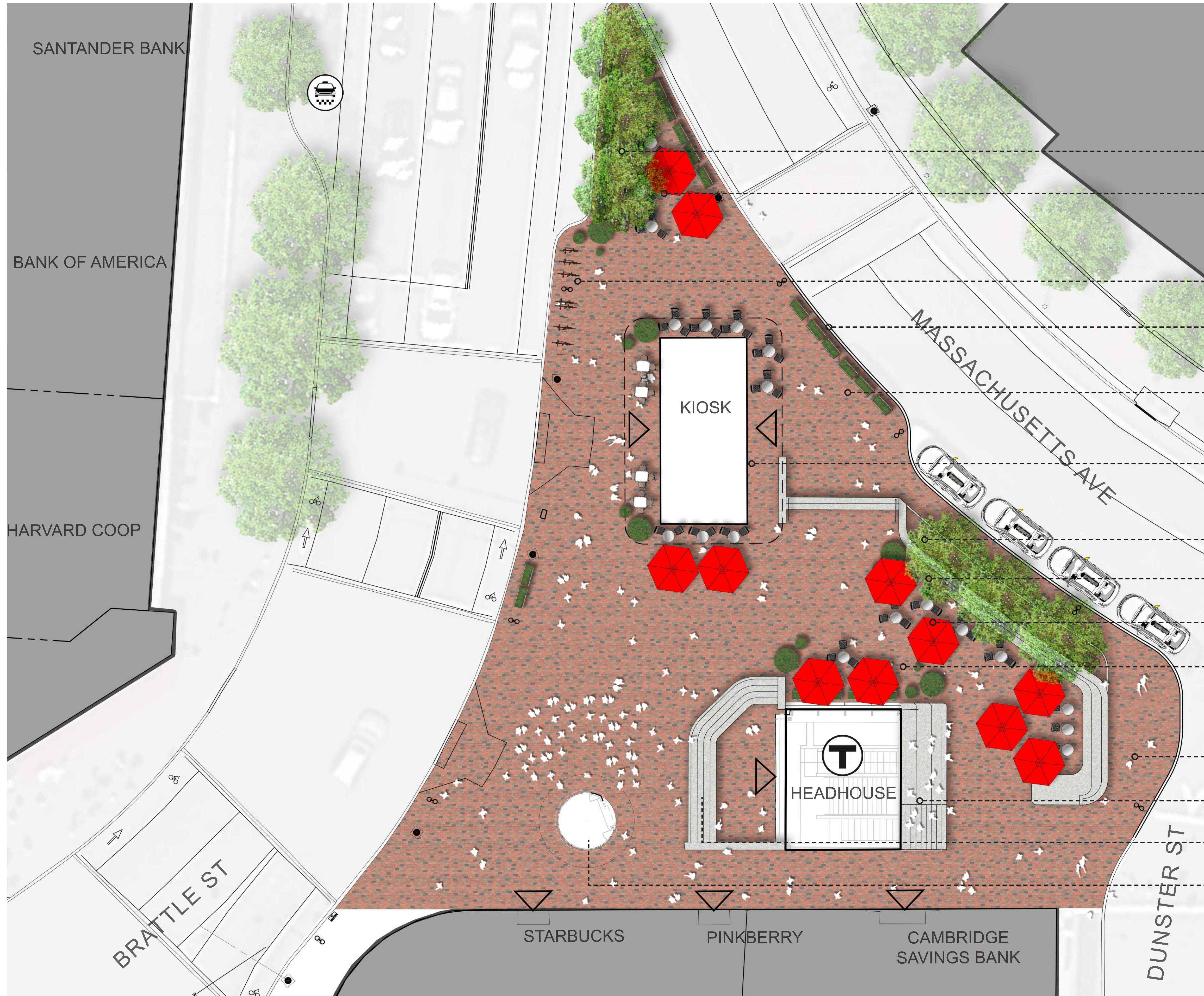

- TREES IN PERMEABLE PAVERS
- TABLES AND CHAIRS
- BIKE RACKS
- PLANTERS AND BOLLARDS TO ENHANCE SPACE
- REMOVE ONE TAXI SPACE TO AMELIORATE PINCH POINT
- LOWER FINISH GRADE OF KIOSK FOR ACCESSIBILITY
- TREES IN PERMEABLE PAVERS
- RETAINING SEAT WALL
- TABLES AND CHAIRS
- LEVEL FLEXIBLE PLAZA SPACE
- WIDENED SIDEWALK
- TERRACED SEATING FEATURE
- RECONFIGURED STAIRS
- NEW GLASS MBTA ELEVATOR



DAILY USES



HARVARD SQUARE - CAMBRIDGE, MASSACHUSETTS
APRIL 25, 2018

TEMPORARY USES

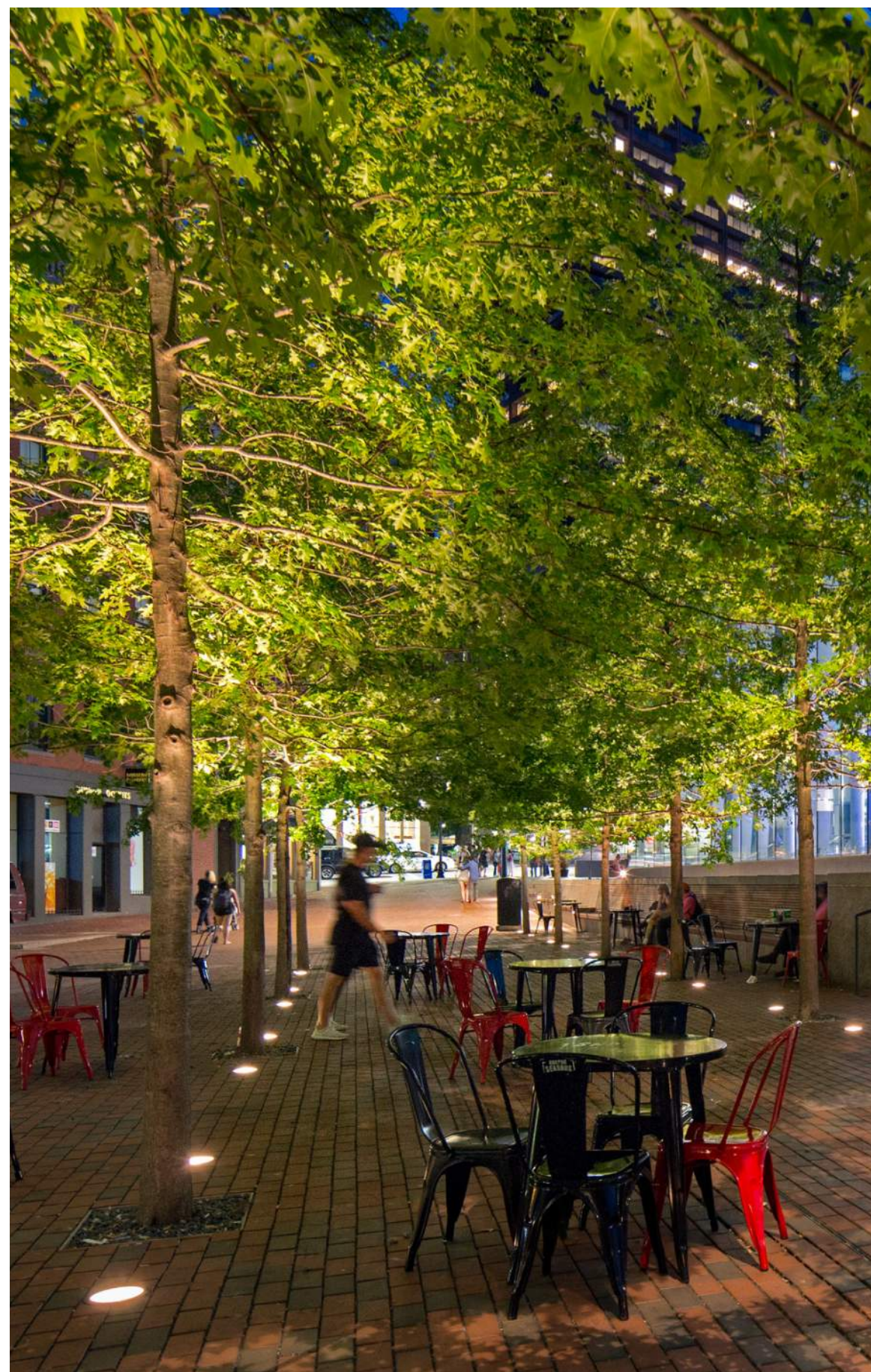

Special Lighting Opportunities

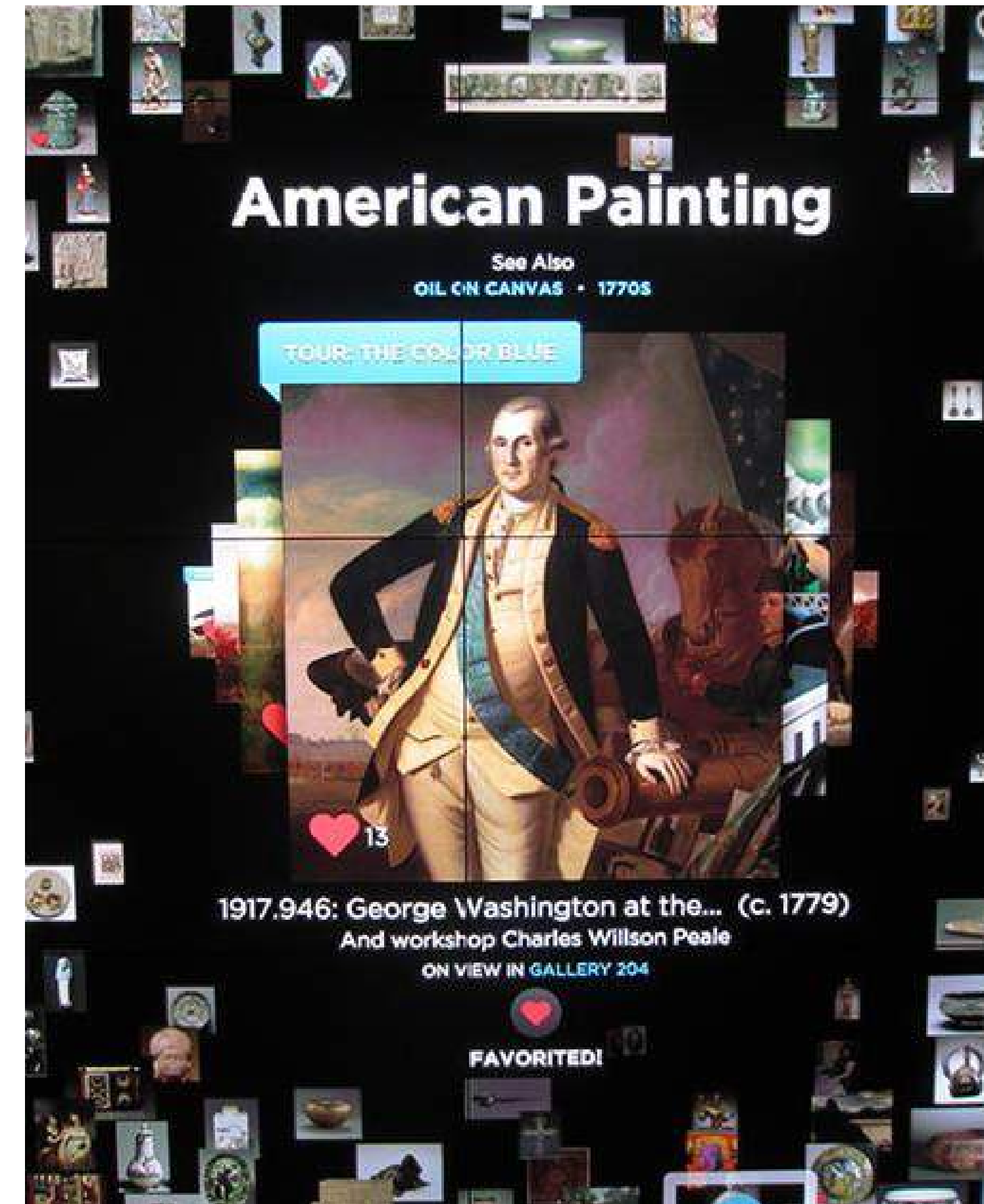

One thing that has remained true is the connection between Harvard Square and the printed word.

“This is a place of history, of books, of ideas, and of learning”



Home of the first printing press!



21st Century Wayfinding/Tourism

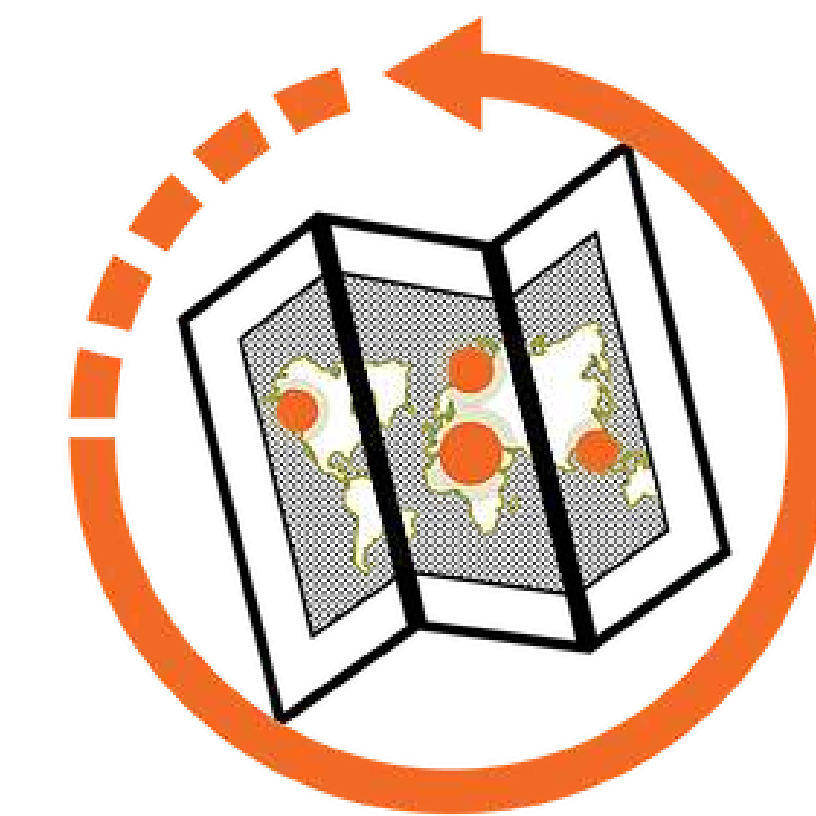

PRECEDENT IMAGES



- DAILY USES**
- SEATING AREAS
 - TABLE GAMES
 - TOUR GROUPS
 - STREET PERFORMERS
- TEMPORARY USES**
- PUBLIC PIANO
 - ARTISTIC SCULPTURE/SEATING
 - STORYTELLING
 - FACE PAINTING
 - TABLING FOR COMMUNITY GROUPS
 - ART VENDORS
 - FARMER/FLEA MARKET
 - FOOD FESTIVALS
 - RALLIES
 - PERFORMANCES

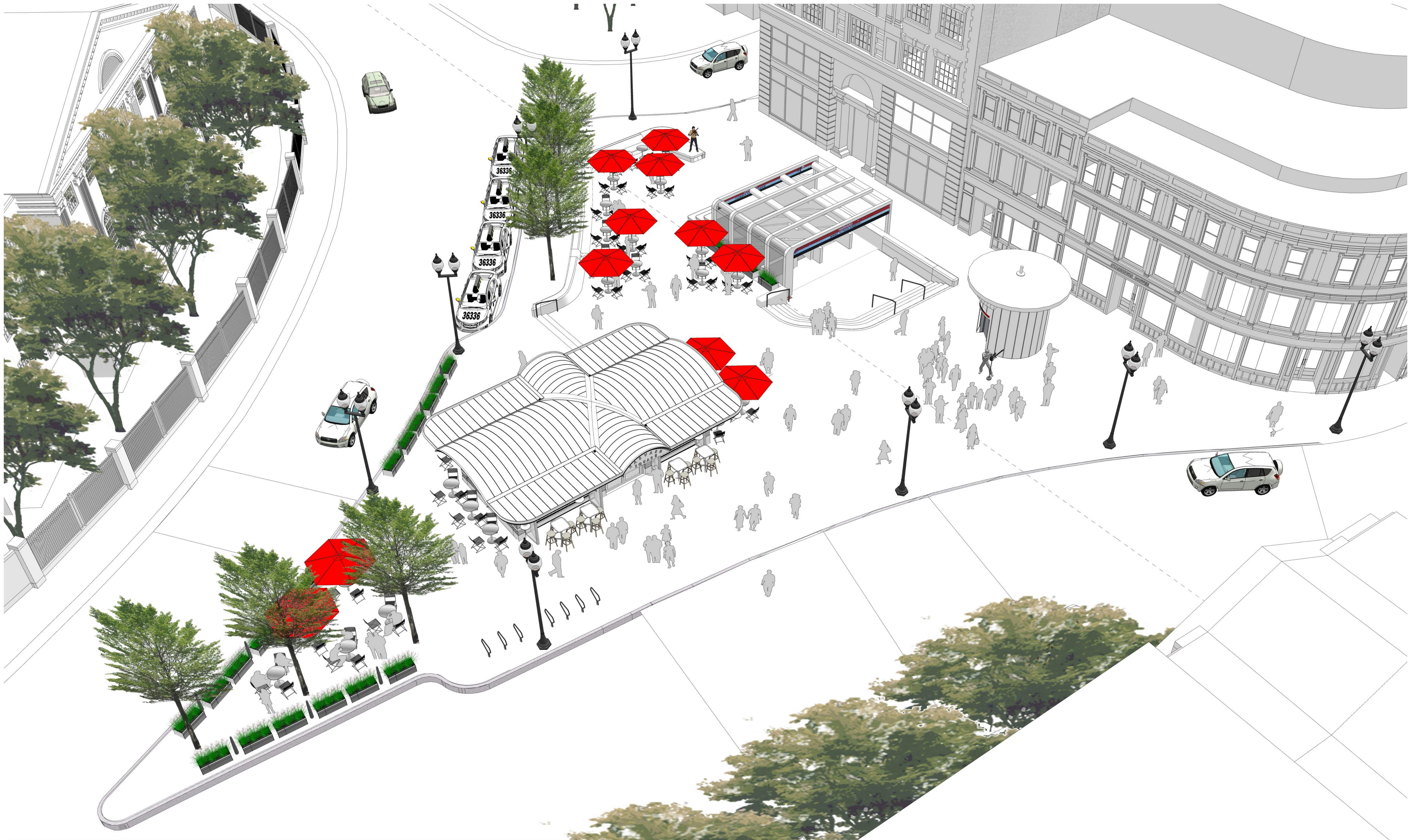

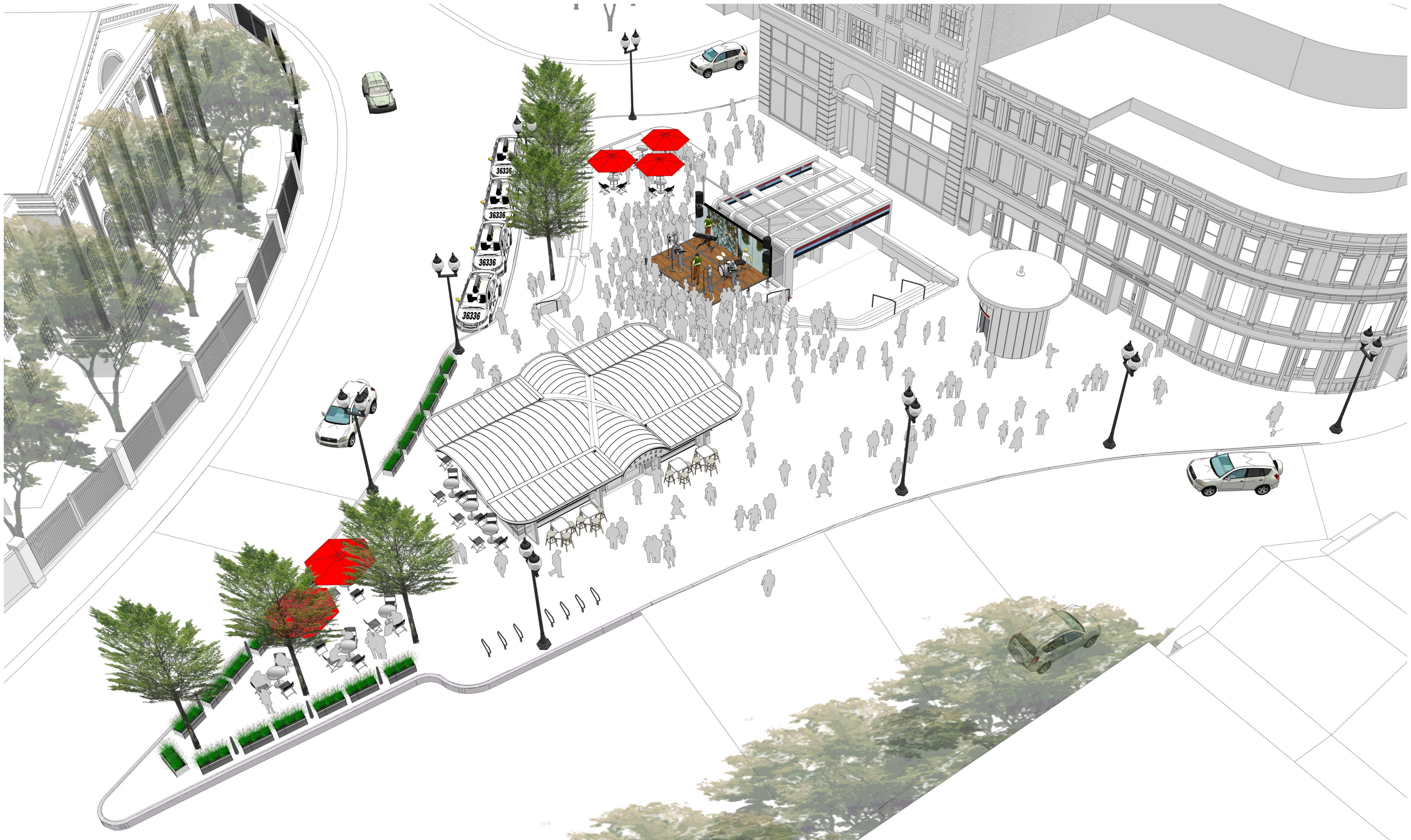

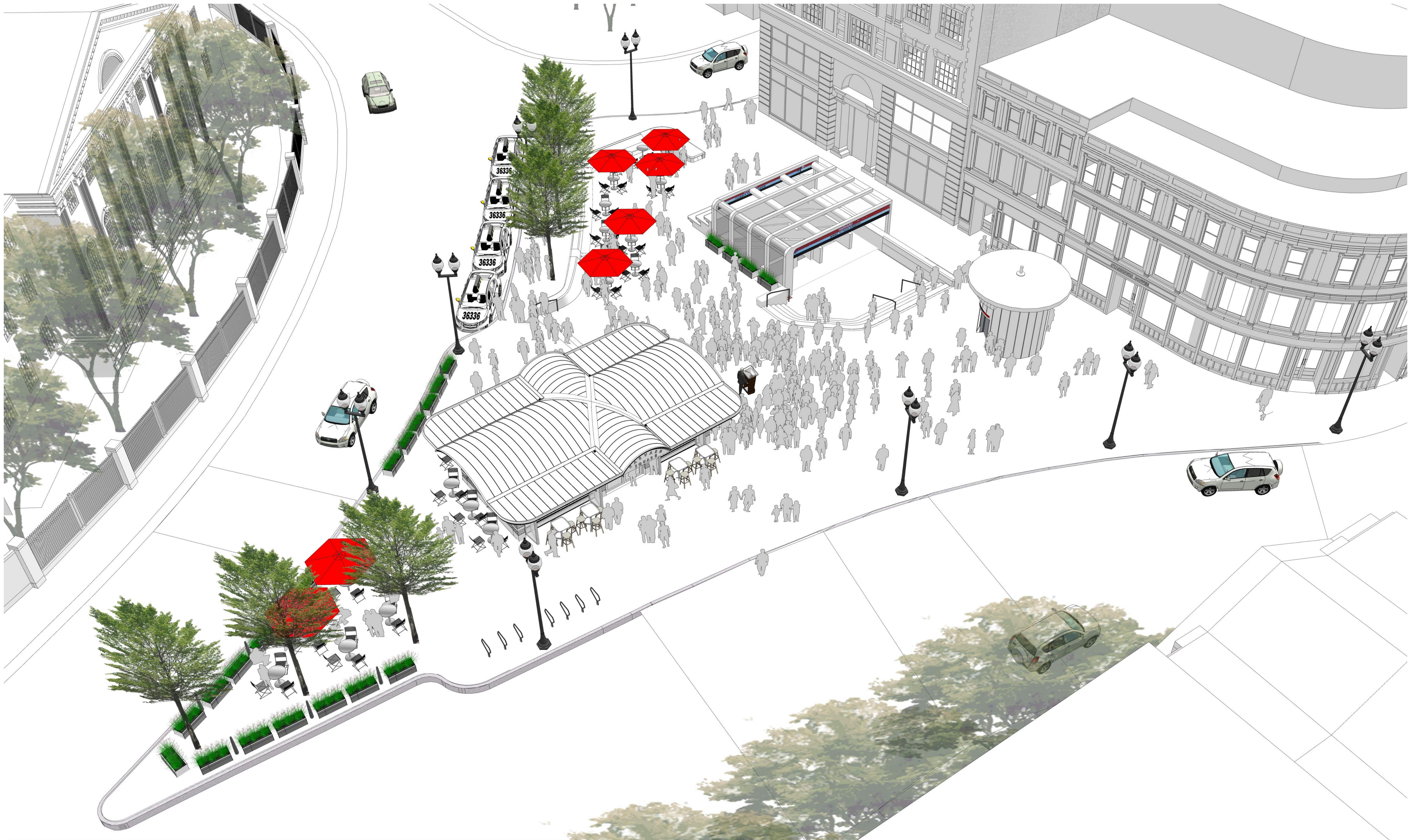

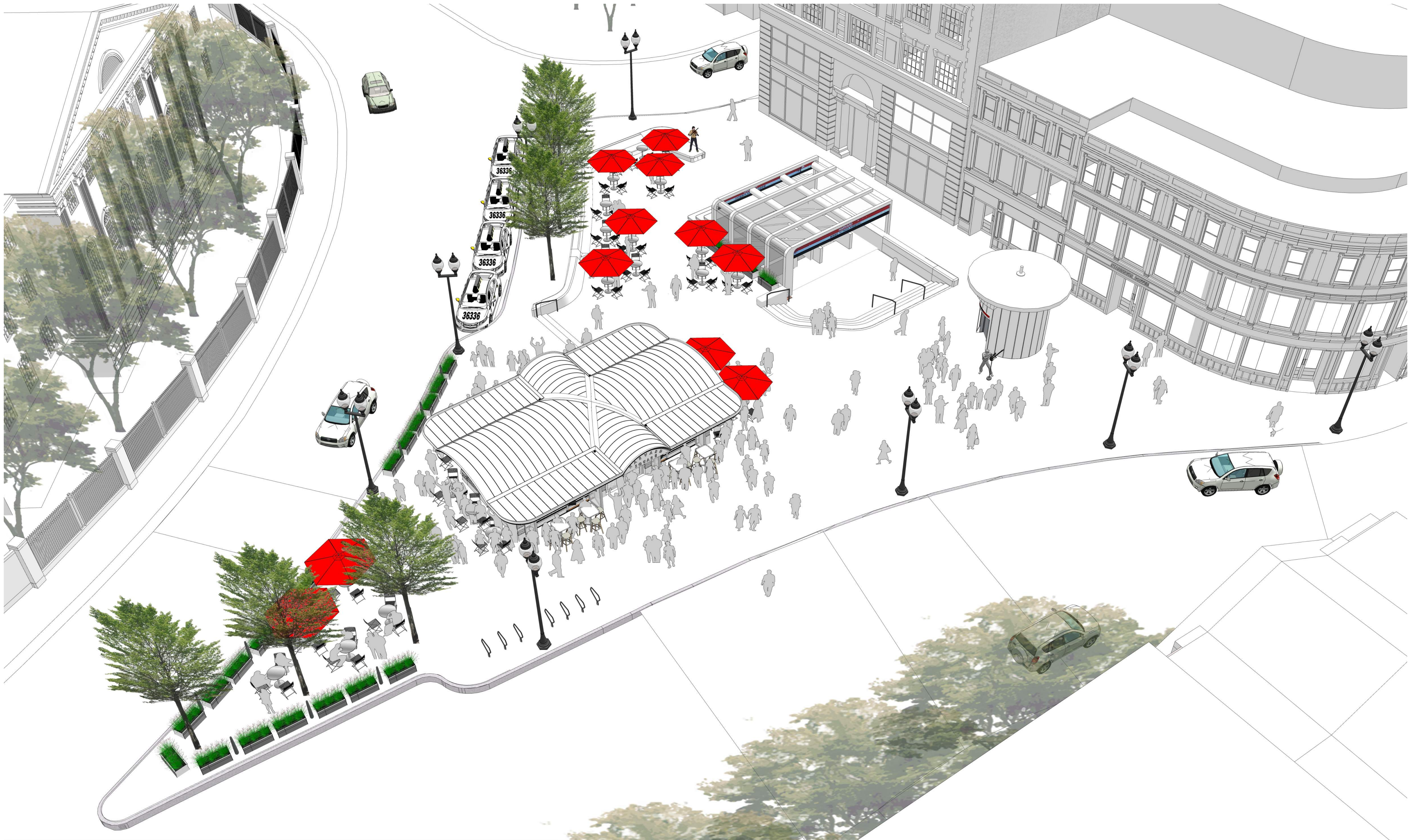

PROGRAMMING OPPORTUNITIES - TEMPORARY USES - KIOSK PERFORMANCE



PROGRAMMING OPPORTUNITIES - TEMPORARY USES - FLEA/FARMERS MARKET

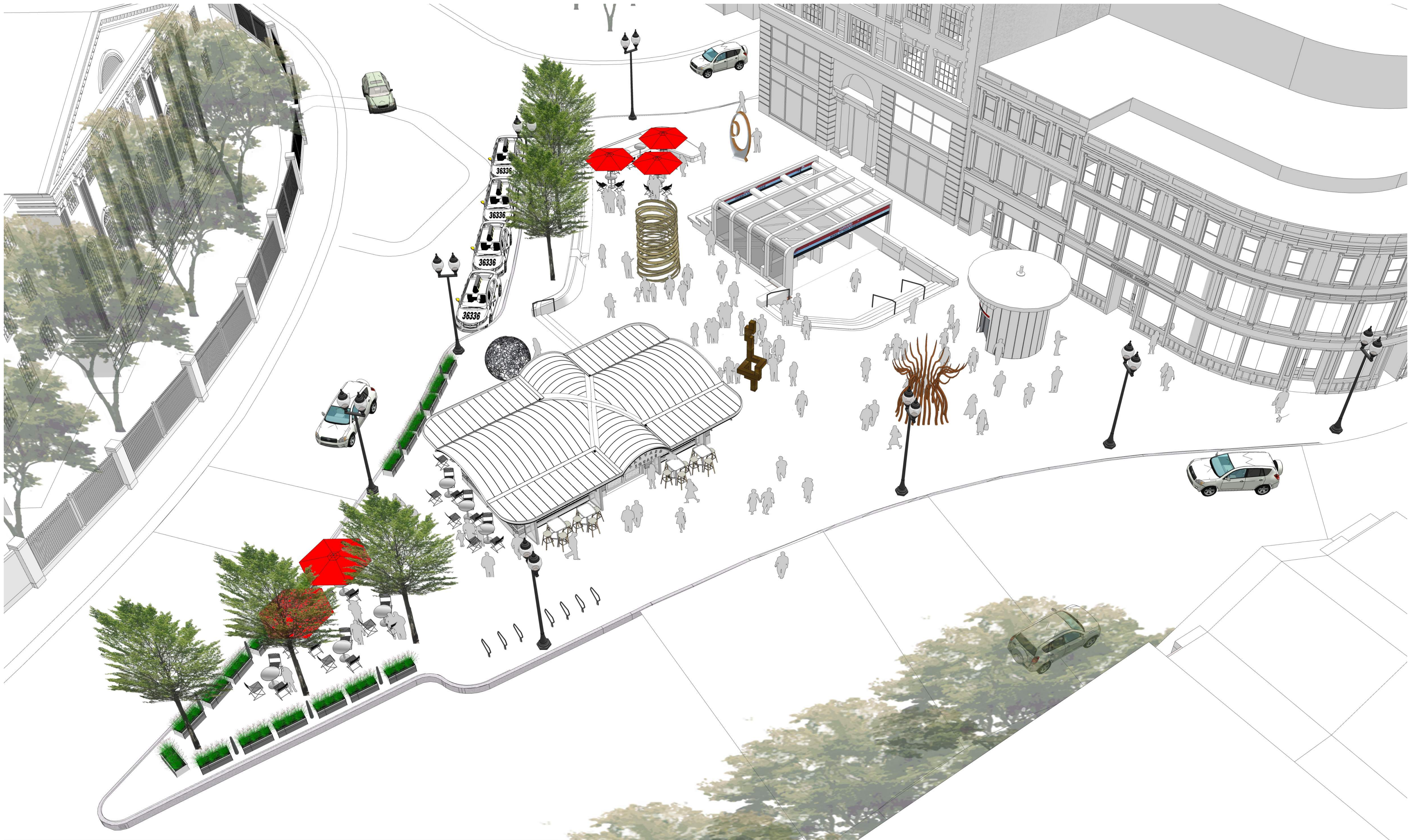

PROGRAMMING OPPORTUNITIES - TEMPORARY USES - ART/SCULPTURE EXHIBIT

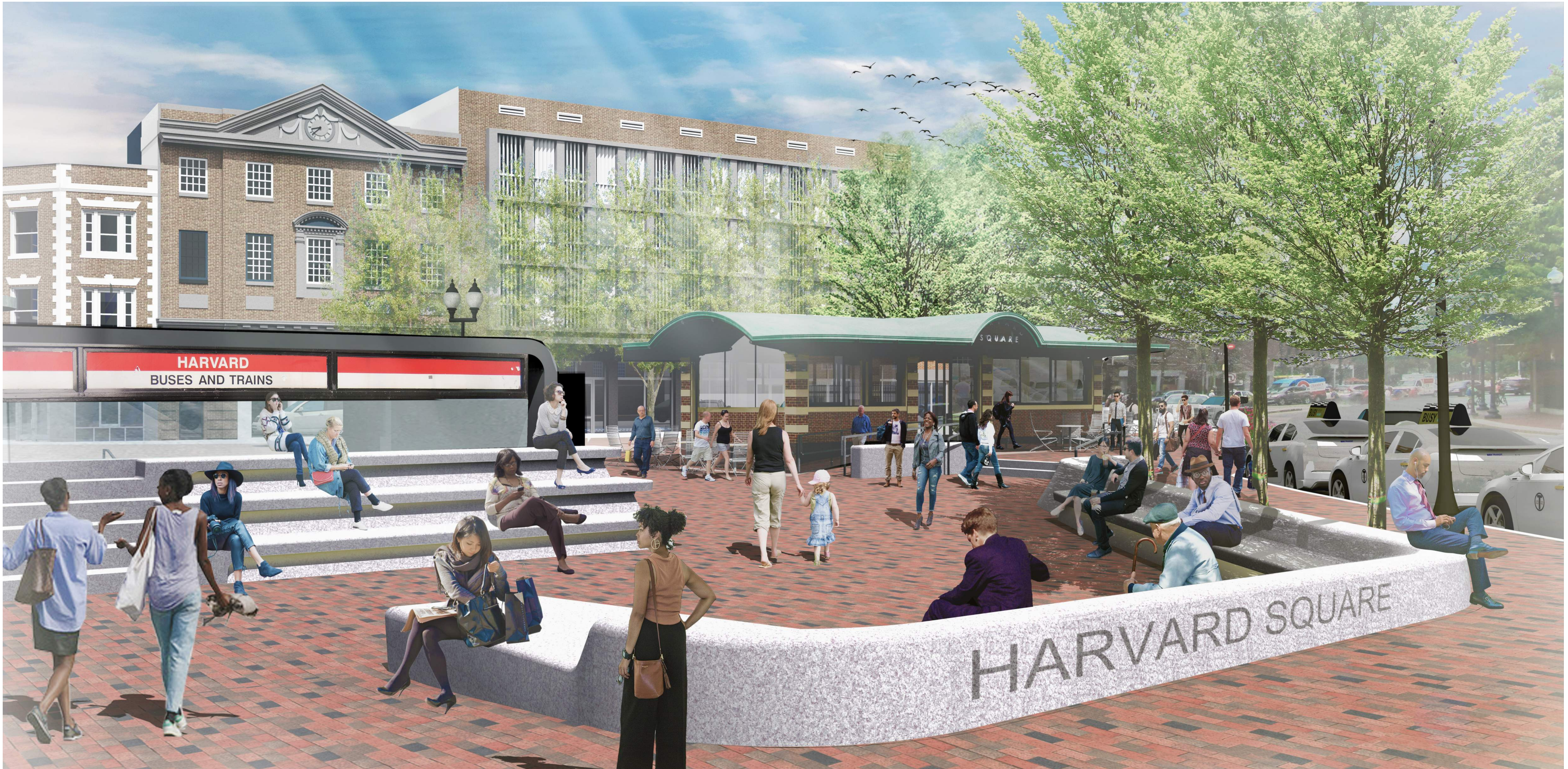





Harvard Square Kiosk

1. Historic Preservation Approach
2. Kiosk Program Use Options
3. Kiosk Exterior Window/Door Options
4. Kiosk Signage Options



Harvard Square - 1970's
HARVARD SQUARE - CAMBRIDGE, MASSACHUSETTS
APRIL 25, 2018

Timeline

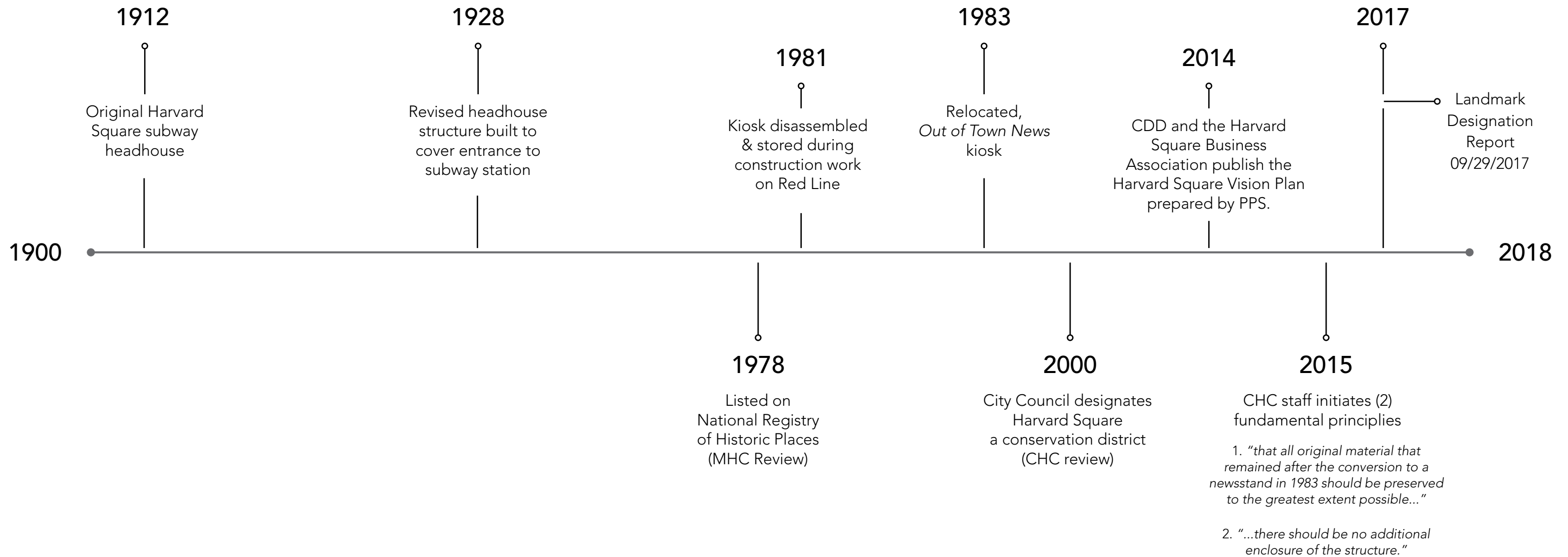

"Original" Kiosk



Harvard Square Kiosk - 1977



Harvard Square Kiosk



Harvard Square Kiosk

"Original" Kiosk

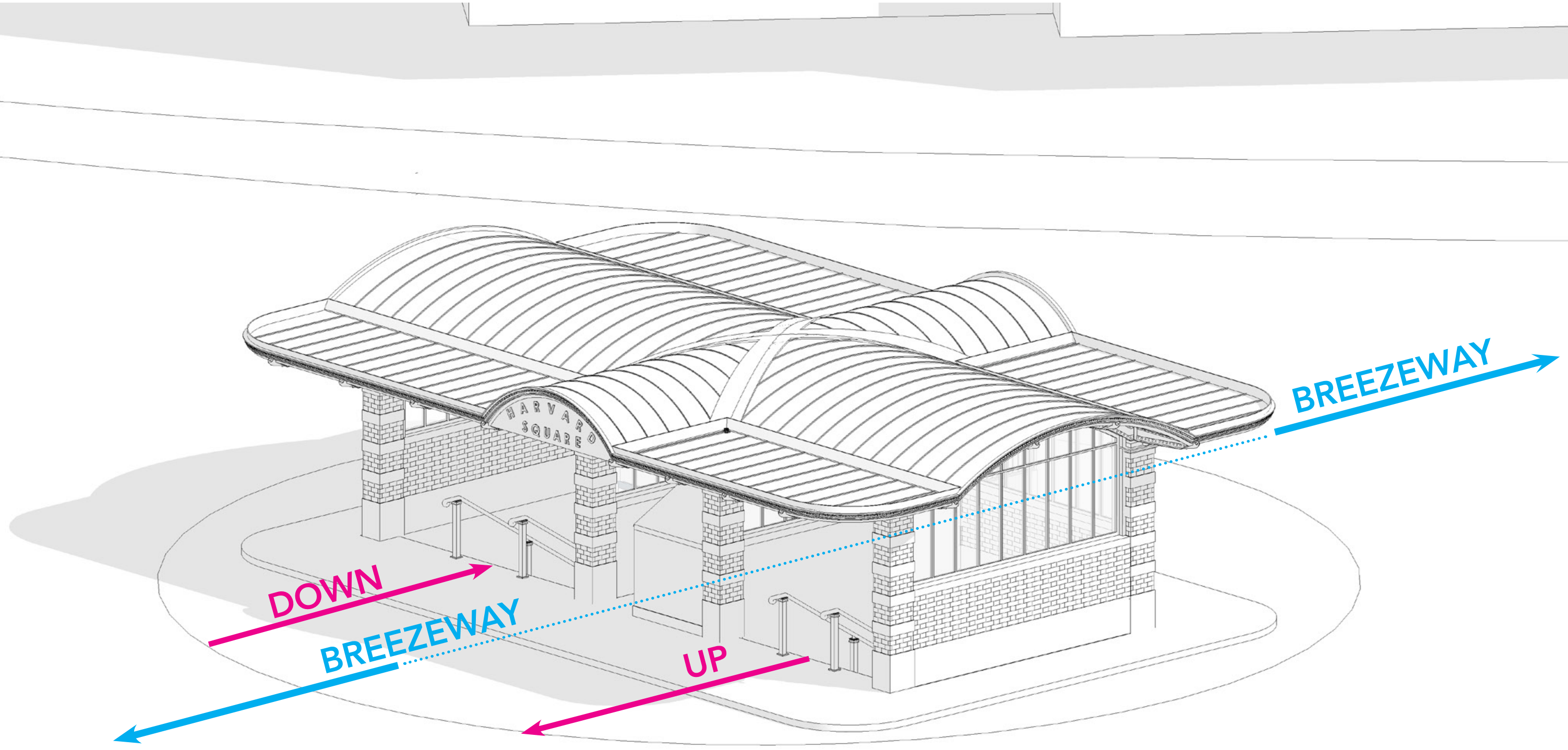

1983

"...all original material that remained after the conversion to a newsstand in 1983 should be preserved to the greatest extent possible, and that there should be no additional enclosure of the structure."

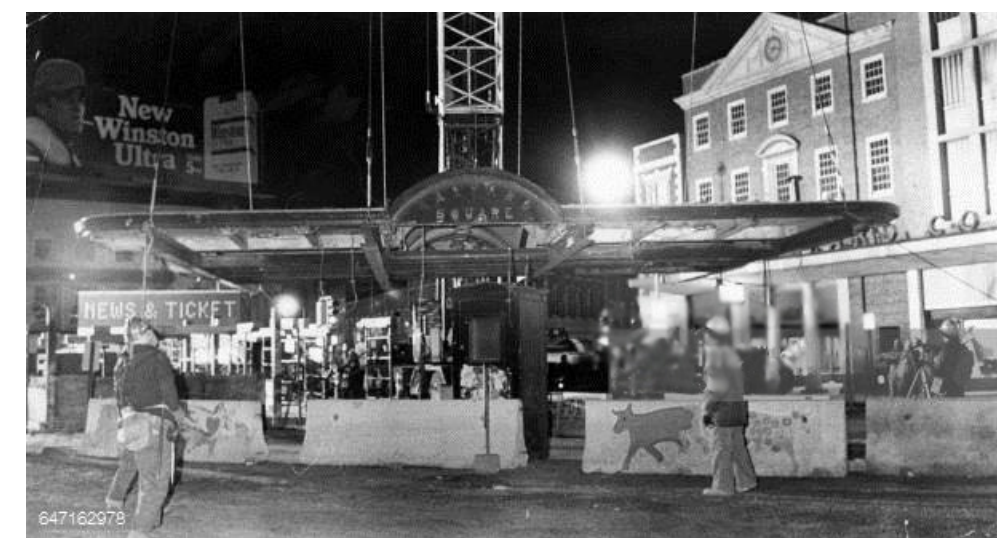
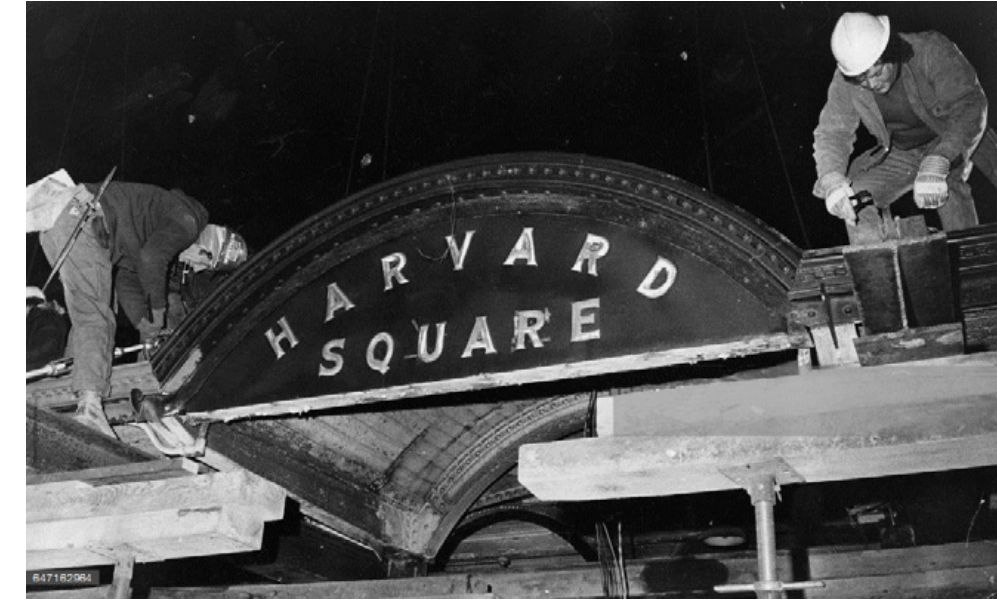

1983 relocation of kiosk roof & structure (photo credit: Boston Globe)

moving of kiosk roof & structure (photo credit: Boston Globe)

Exterior Kiosk Today



Existing Kiosk Today

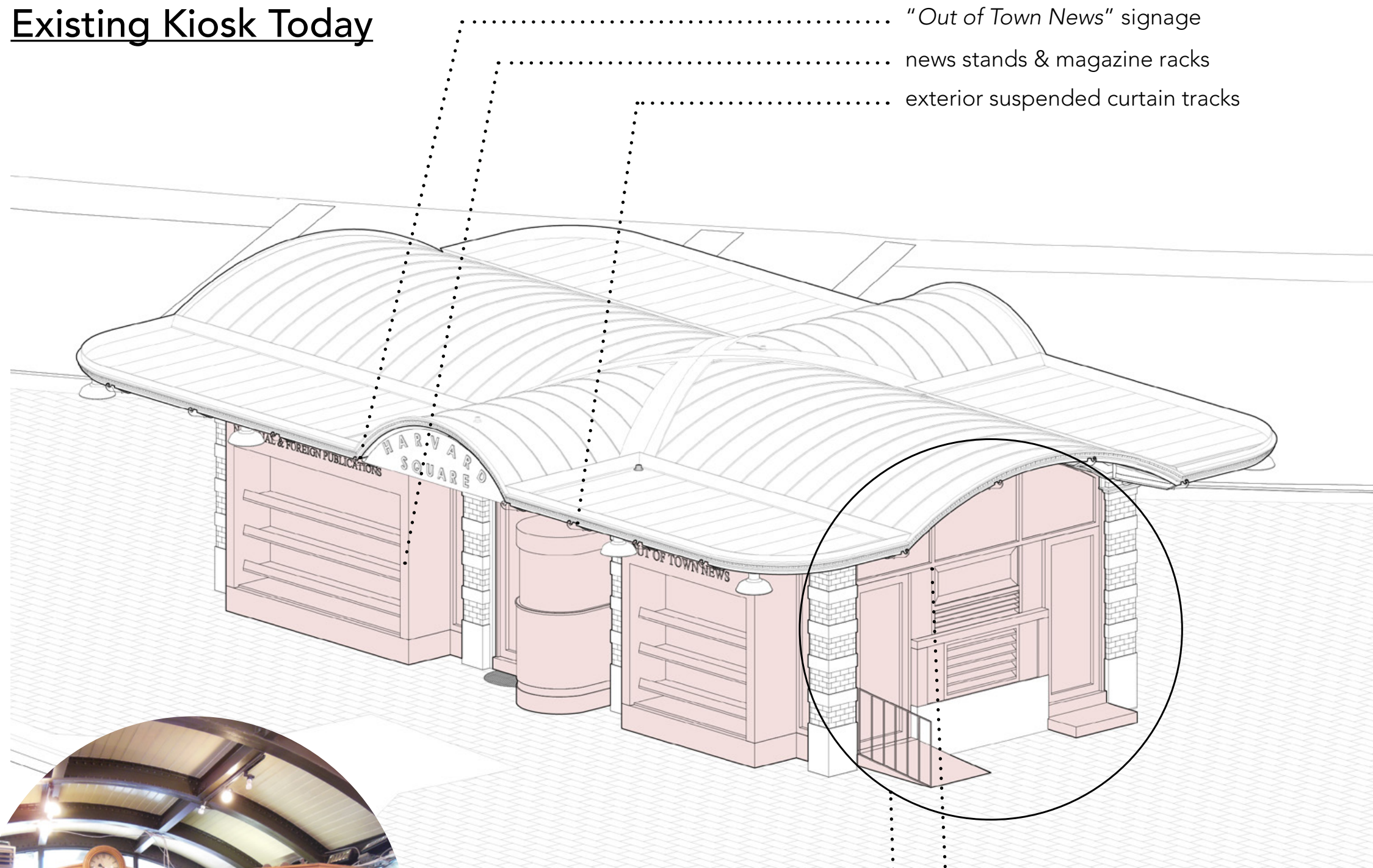

present day kiosk - exterior



present day kiosk - exterior



present day kiosk - interior

interior

- interior casework & electrical room
- select interior light fixtures
- interior heating & cooling systems

- aluminum framed storefronts
- south elevation fenestration, vents, doors & ramp

Landmark Designation Report Guidelines

Historic Preservation

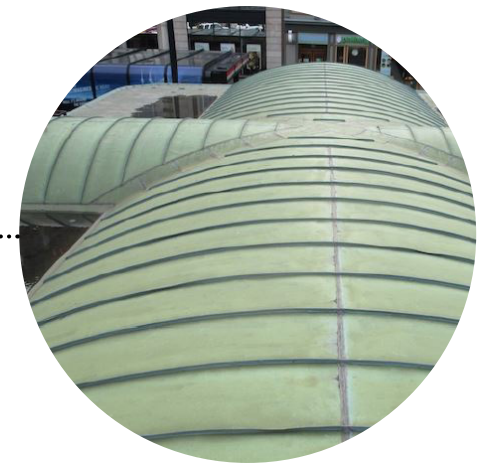
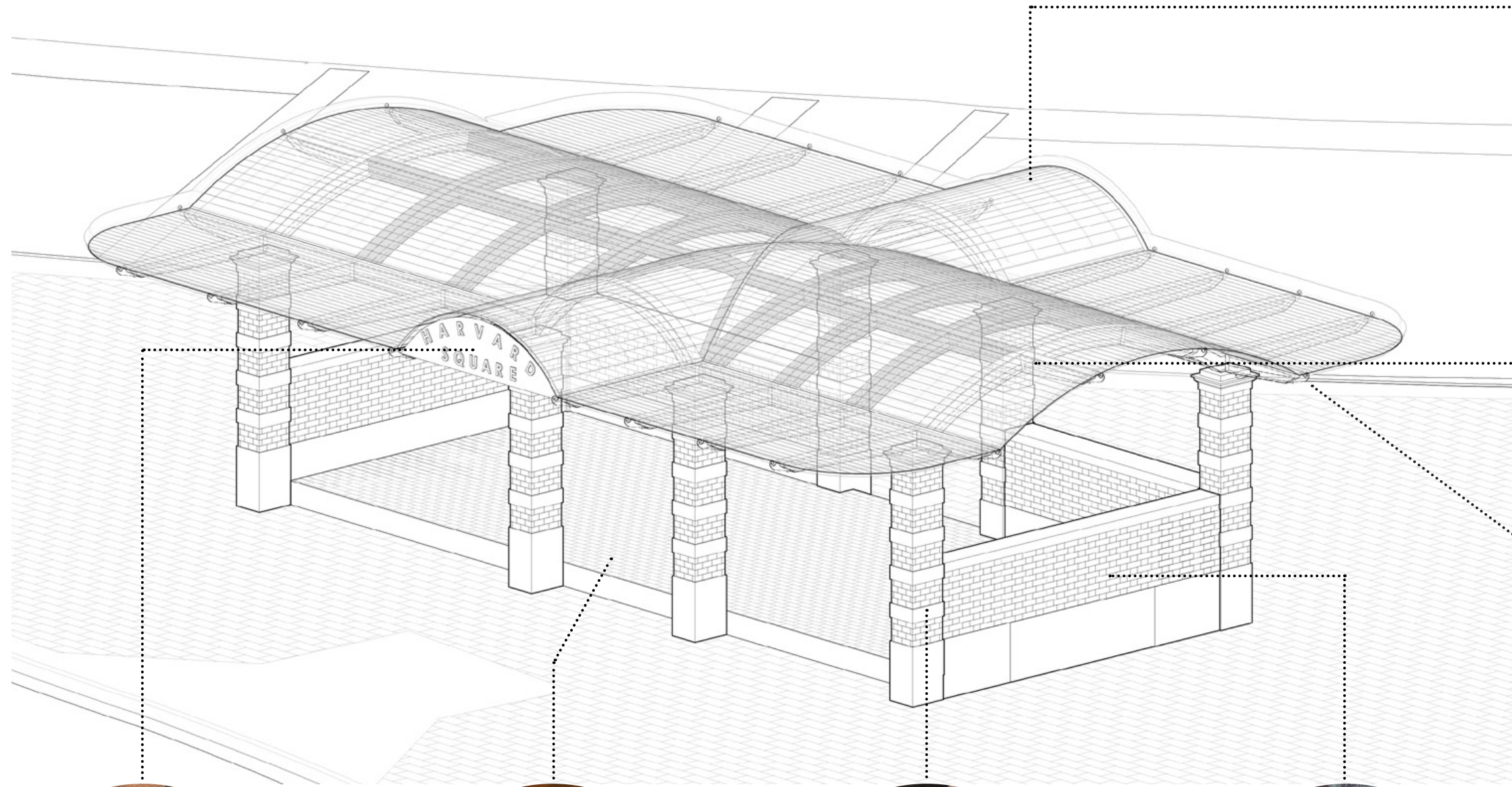

standing seam copper roof



riveted iron structure & exposed wood beadboard



exterior signage

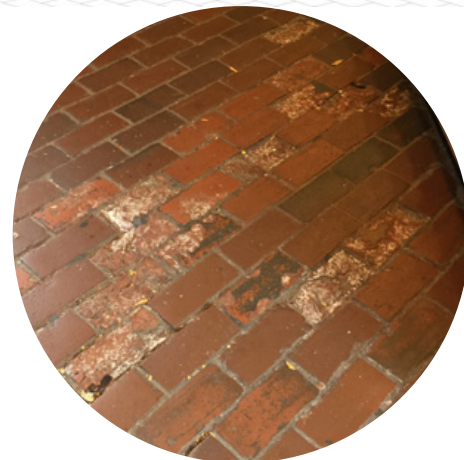

brick flooring



masonry and limestone piers



perimeter brick wall with granite base



metal cornice

Preservation Research

Original Drawings

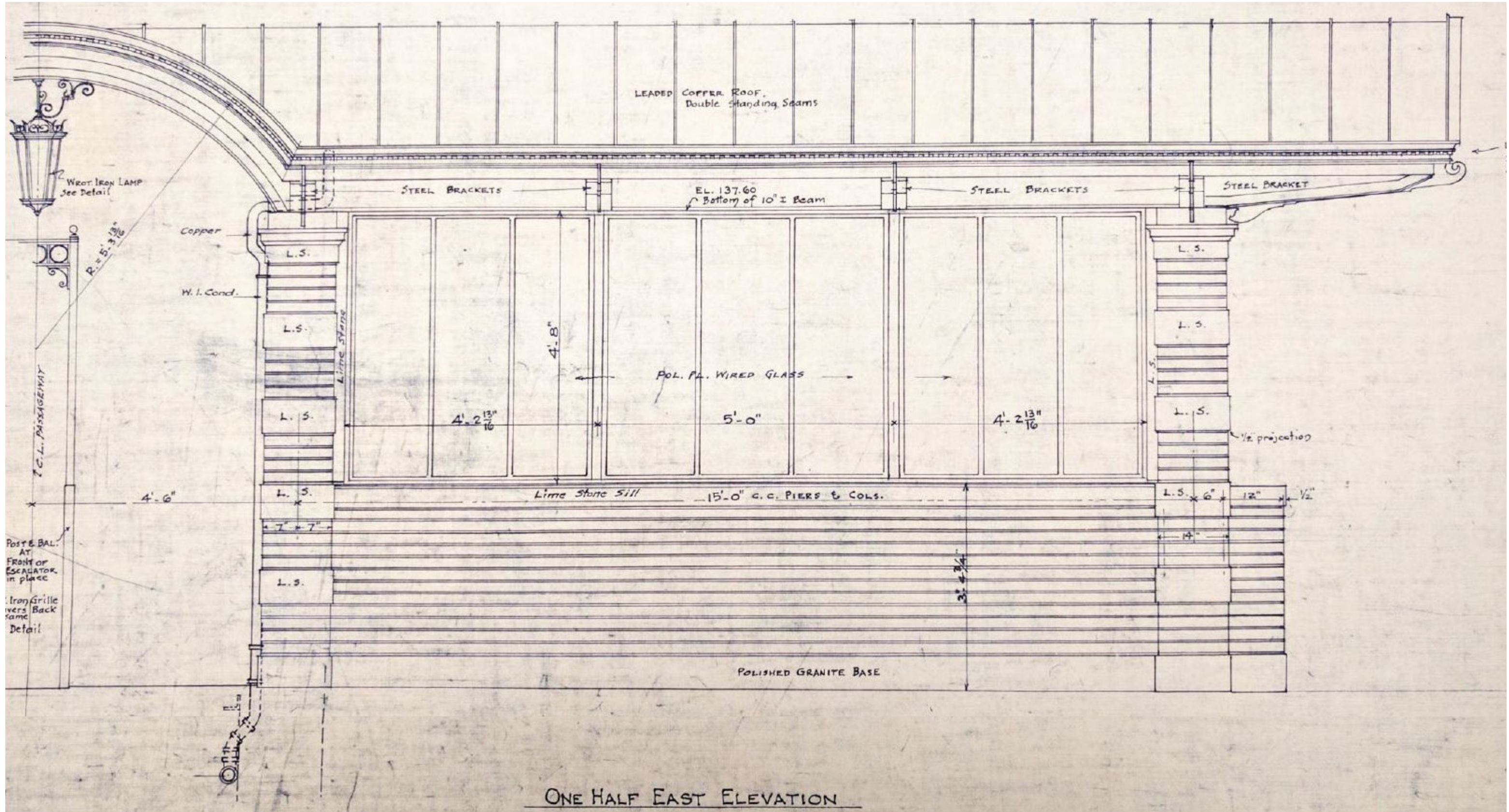

Masonry Opening Opportunities

Fenestrations

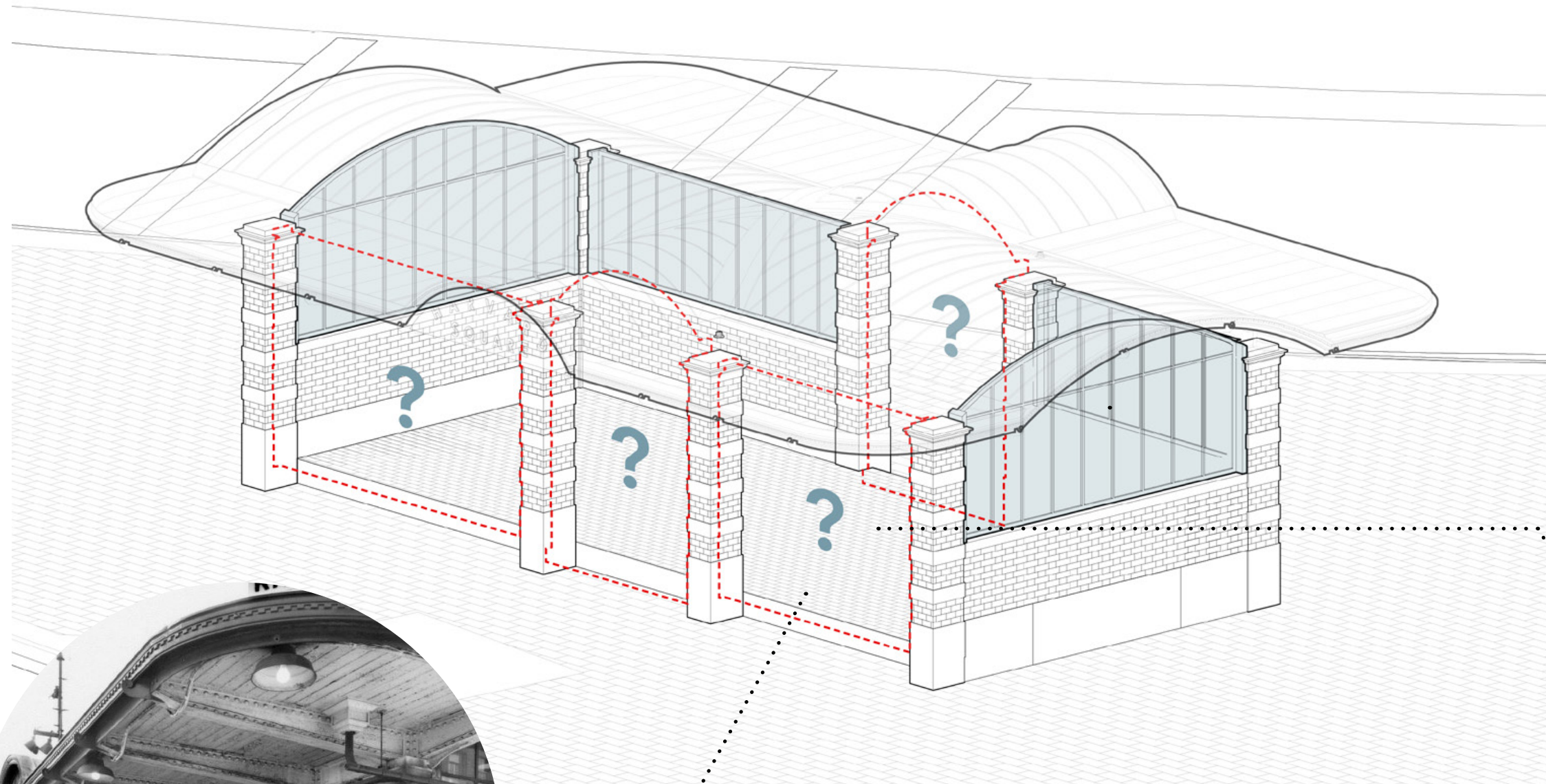

provide new windows



original entrance into the train



removal of magazine racks

Kiosk and Plaza Relationships



Exterior Envelope Equation

$(\text{Interior Use} + \text{Exterior Use}) \times \text{Historical Significance} / \text{Surrounding Site} = \text{Highest and Best Exterior Envelope for Flexible and Adaptable Uses}$



How opportunities relate to the use of the plaza and building.

Uses

We realize that each plaza space will be supported differently based on the programmatic use of the kiosk and that the facade should respond accordingly.

Plaza

Daily Uses

- Seating areas

Temporary Uses

- Table games
- Performance / Events
- Interactive installations (ex: public piano; artistic sculpture/seating)
- Family activities (ex: storytelling; face painting)
- Tabling for community groups
- Outdoor markets (selling books, art, and/or food)
- Civic Functions
- Board Games
- Street Performers
- Tour Groups

Kiosk

Daily Uses

- Visitor Information Center
- News
- Interior "flex" space

Temporary Uses

- Family activities
- Performance / Events
- Civic Functions
- Social Seating
- Board Games
- Art exhibit
- Collection of clothing/food donations
- Small lecture/roundtable style event (ex: book talk)
- Sampling of products
- Historical exhibit



Consolidated: variety of rotating events

- * flexible and adaptable spaces
- * grow and change with the community, local business and visitor interests.

Uses

Daily Uses



Visitor Information



News

Temporary Uses



Family Activities



Civic Functions



Social Seating



Board Games



Performance/Events

Daily Uses: Visitor Information & News Case Studies



Chicago Visitor Center - Brochures



Visitor Center - Personal Assistance



NYC Visitor Information - Multi-Lingual Information



NYC Visitor Center - Interactive Maps



Magazine and Newspaper - Storage



BMW Museum - Interpretative Displays

Daily Uses: Visitor Information & News Locations



Visitor Information

- Digital Information Screens
- Maps (Cambridge Region, and Historical)
- Pamphlets
- Brochures
- MBTA information

News

- Public Service Announcements
- Entertainment Information
- Advertising
- Newspapers
- Magazines (Local and Foreign)



Location 1

North & South Walls at existing masonry
Set below the existing window openings
Ends of built-ins exposed on East Facade

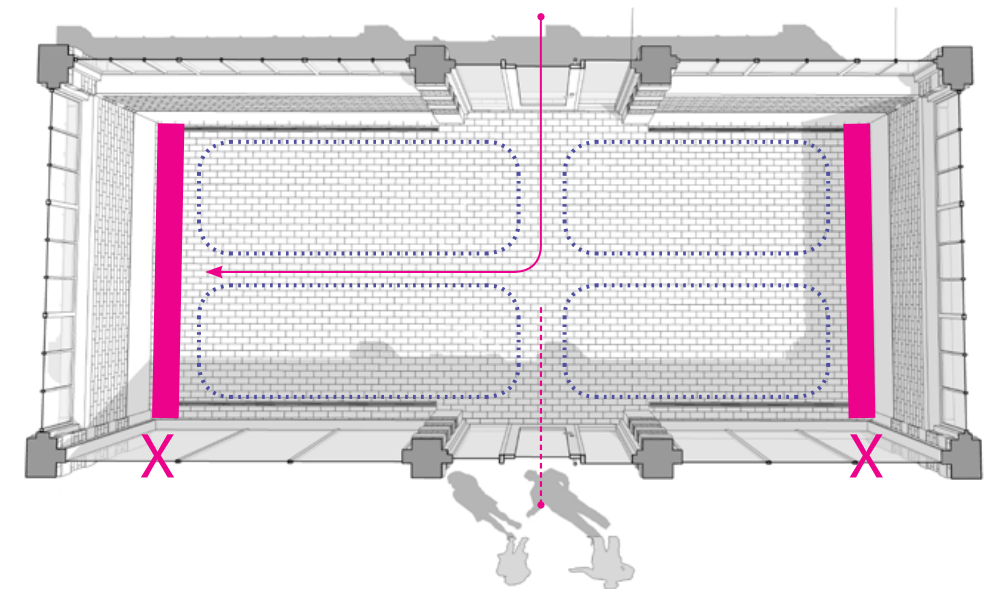

Location 2

East Walls at existing masonry
Set below the existing window openings

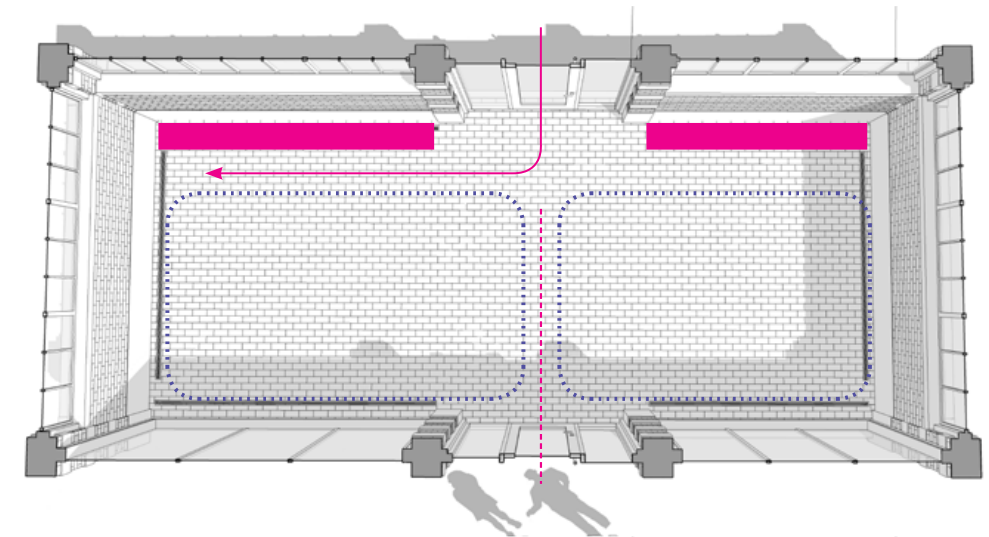

Fixed Casework Options

Location 3

West Walls, no existing masonry
Built-ins would block/obstruct possible glazing and/or operable doors

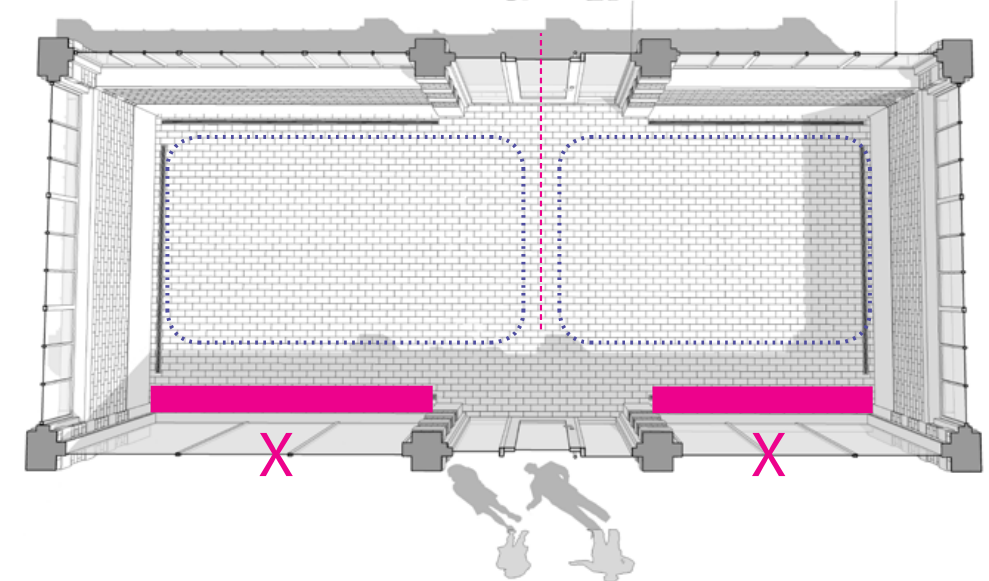

← NORTH

Daily Uses: Visitor Information & News Content



Multi-Lingual Information



Brochures



Interpretative Displays

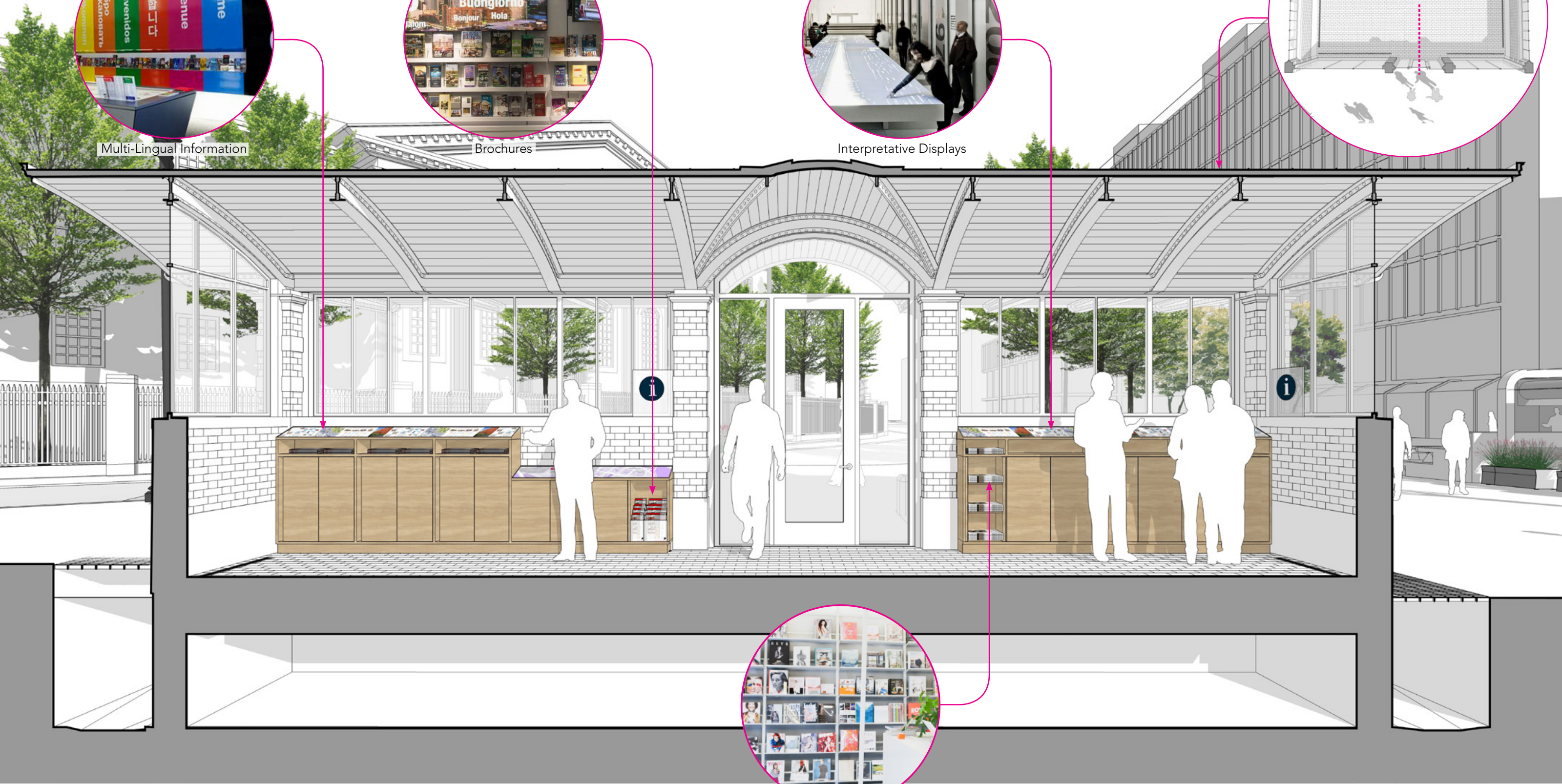
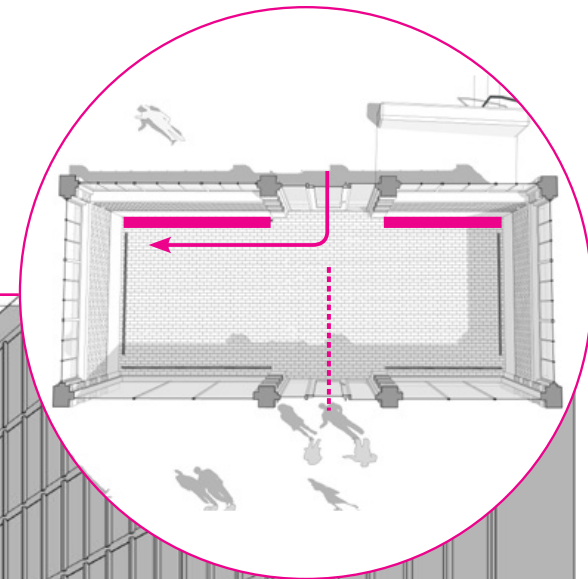

Storage

Section - North/South

Test Fit Use Scenario's

Daily Uses



Visitor Information



News



Tables (6)
*Foldable

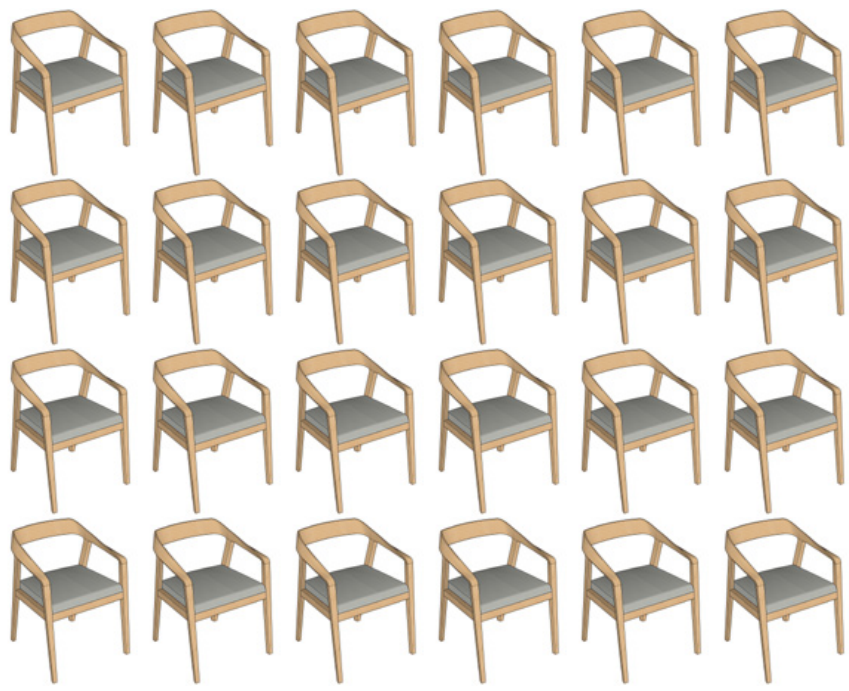

Chairs (24)
*Stackable



Flexible Storage

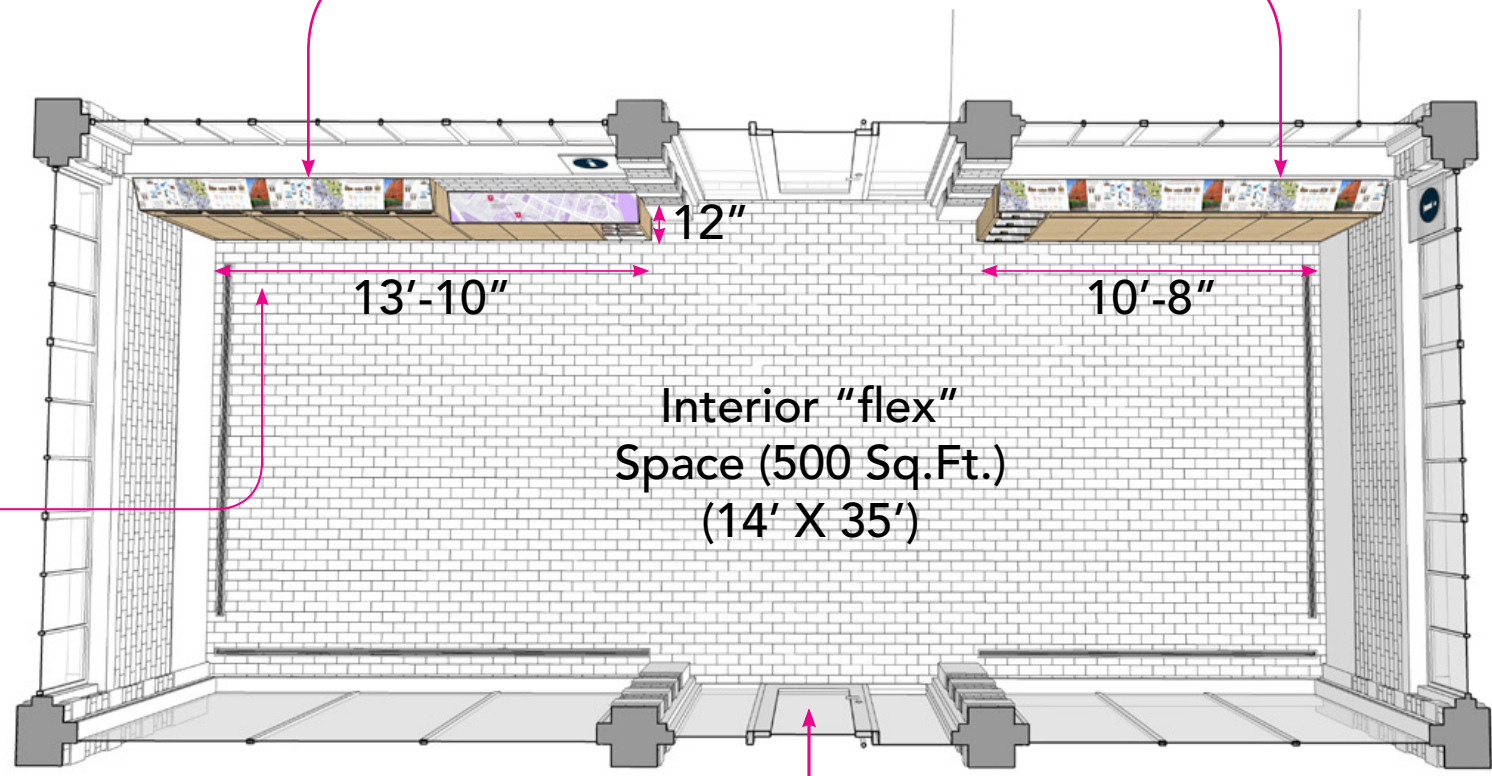

Family Activities



Civic Functions



Social Seating



Board Games



Performance

Temporary Uses

Daily Use: Visitor Information + News



Local Events

<p>APR 4 Brain Rhythms in Health & Disease Symposium MIT Building 46, Room 3002, Singleton Auditorium... Free • on Eventbrite</p>	<p>APR 8 Israel Summit at Harvard 2018 The Charles Hotel, Cambridge, MA Free • on Eventbrite</p>
<p>APR 22 BAH! Fest MIT 2018 Kresge Auditorium, Cambridge, MA Starts at \$5.00 • on Eventbrite</p>	<p>APR 27 COLOMBIA 2040: V Colombian Conference at Harvard + MIT HARVARD + MIT, Massachusetts, USA Free • on Eventbrite</p>

Announcements & Area events

<p>boston.about.com</p> <p>Harvard Square - Walking Tour of Harvard Square-Harvard</p>	
---	--

Tour Information
HARVARD SQUARE - CAMBRIDGE, MASSACHUSETTS
 APRIL 25, 2018

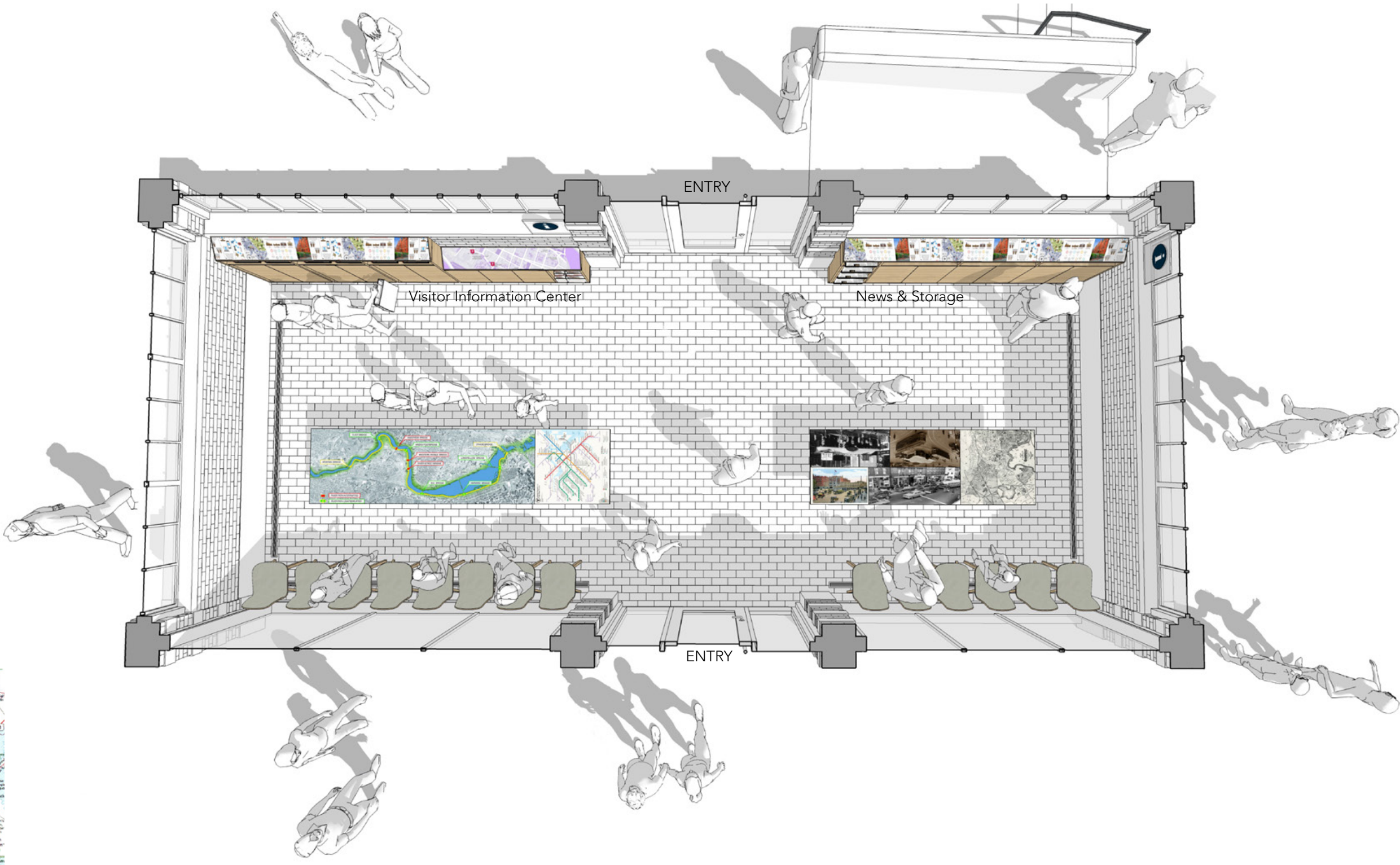

Exterior Facade and Interior Use Opportunities

Exterior Facade Options

1. Fixed Windows
2. Fixed Digital Windows
3. Sliding Windows (Counter Height)
4. Folding Glass Doors
5. Folding Glass Doors with Digital Windows

Signage Options

1. Digital Glass Window (Embedded LED's in IGU)
2. Movable LCD Screen (Interior)
3. Roof Top Signage (Historical precedent)

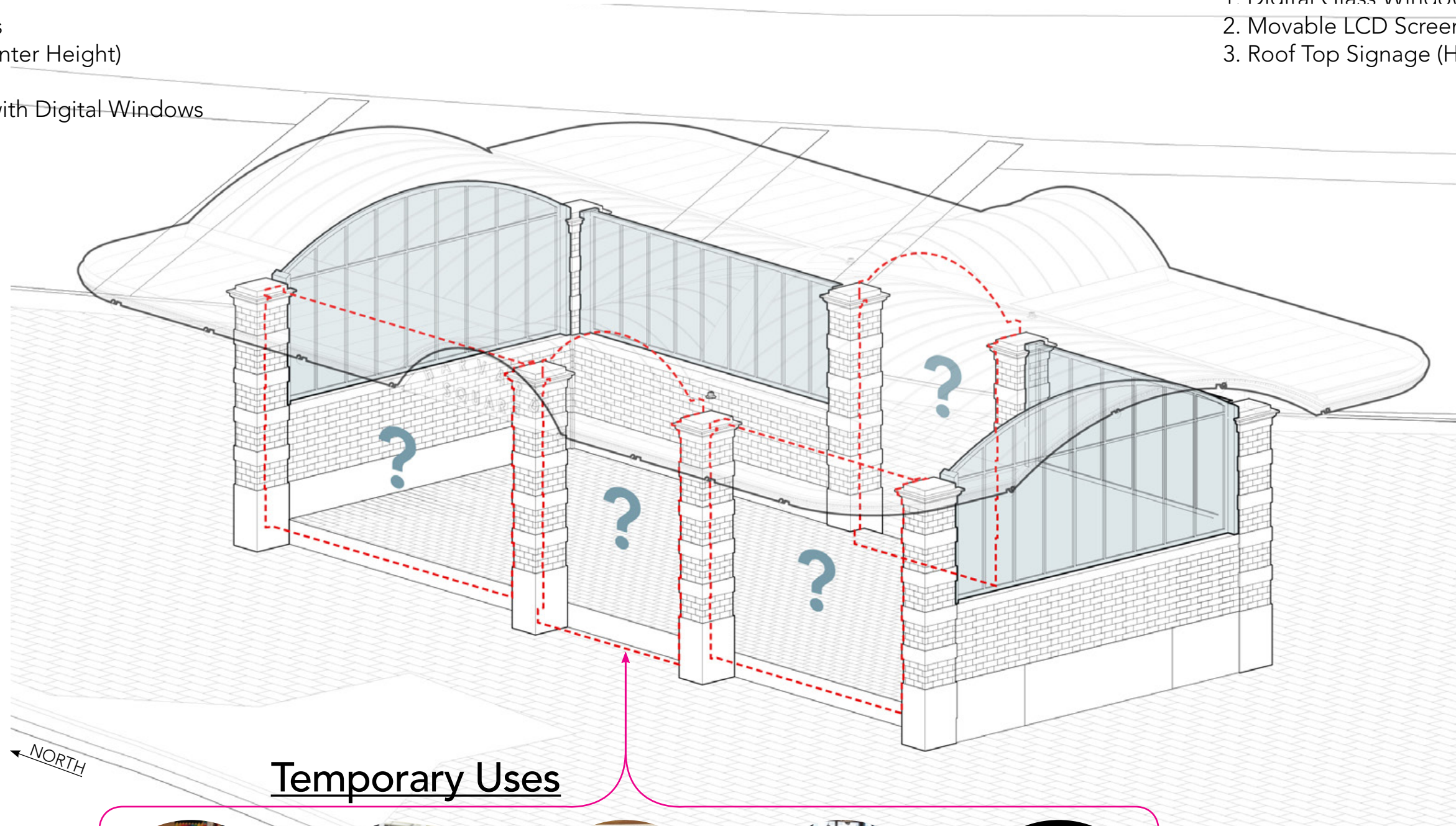

Temporary Uses



Family Activities



Civic Functions



Social Seating



Board Games



Performance

Fixed Windows

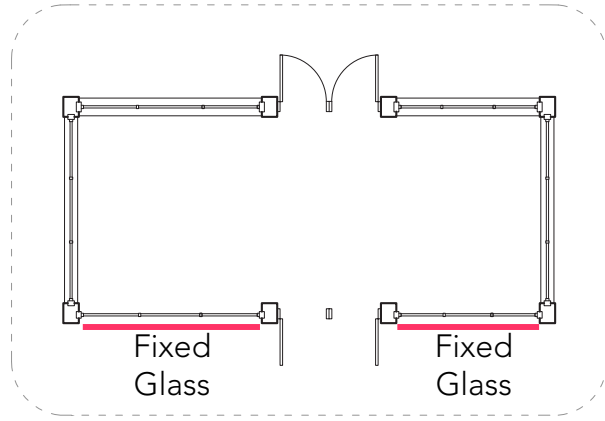

Key Plan



View - Southwest



View - Northeast

Family Activities

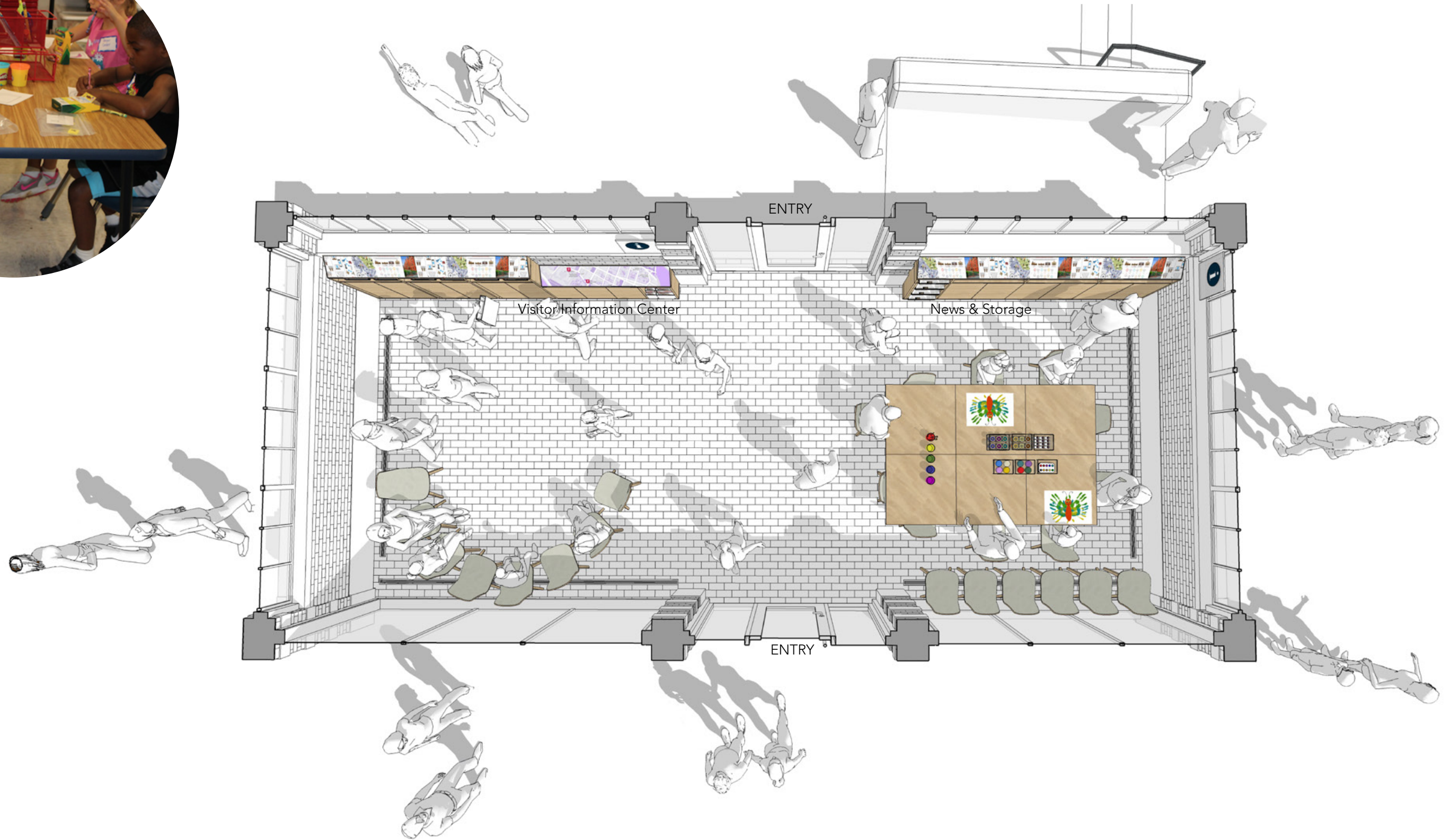

Plan (500 Sq.Ft.) - Diagram

← NORTH

Family Activities



Section - East/West

Fixed Digital Windows

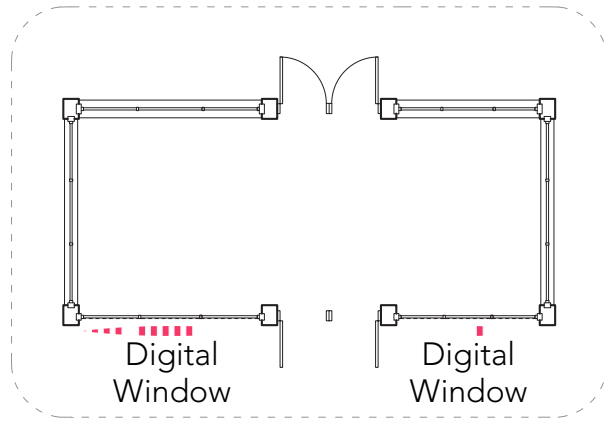

View - Southwest

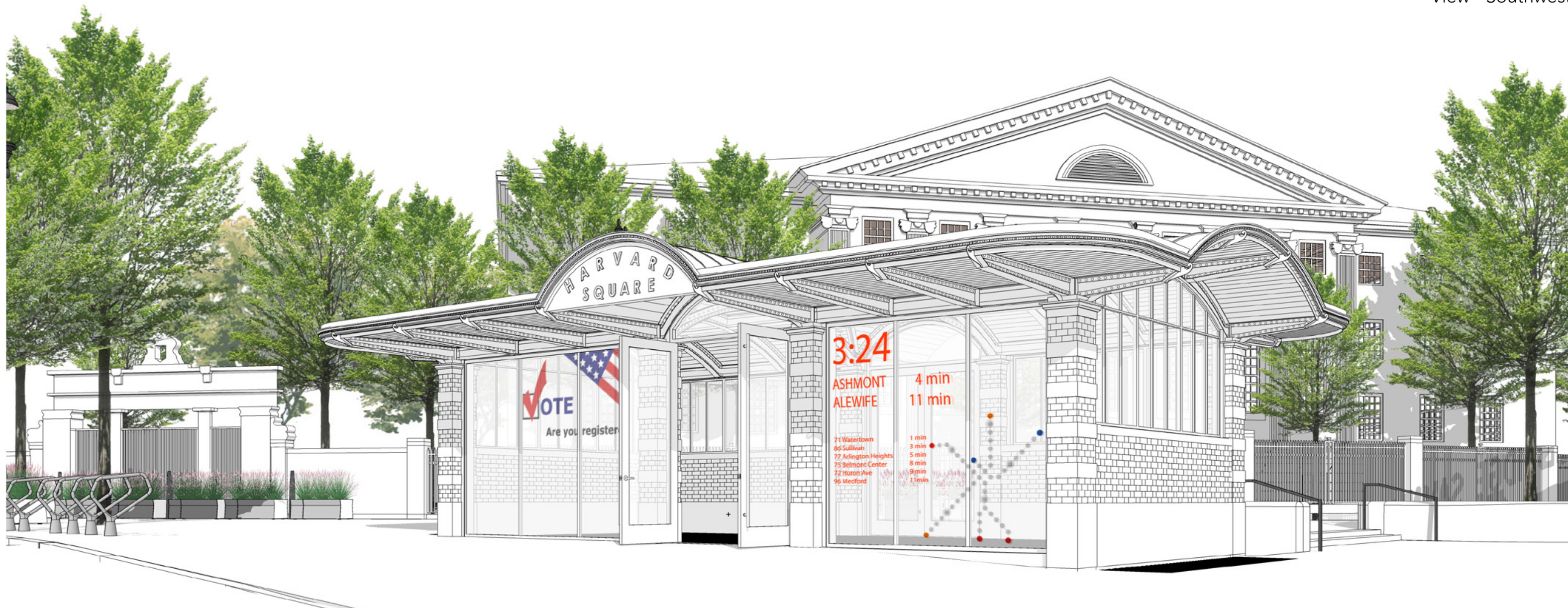

View - Northeast

Civic Functions

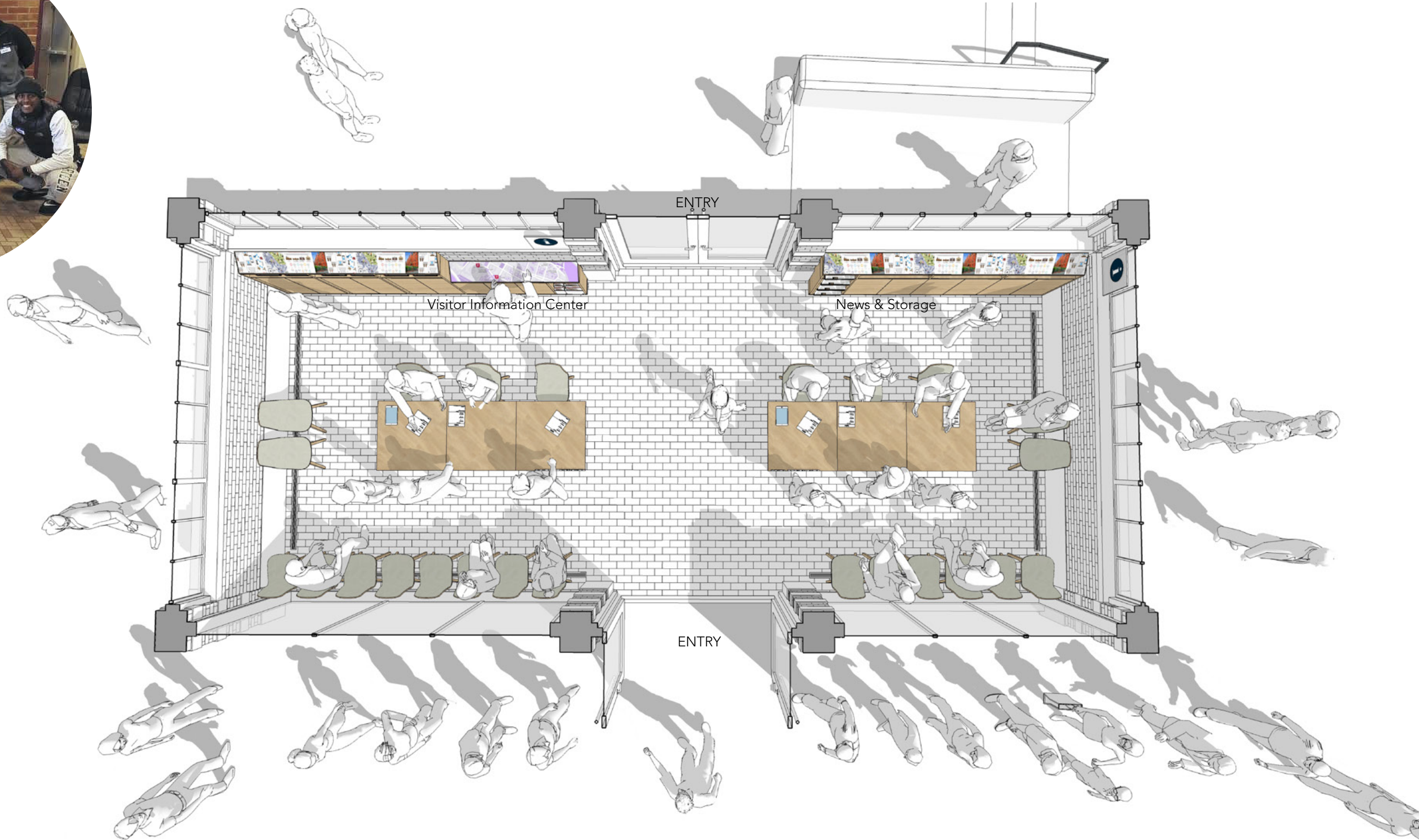

Plan (500 Sq.Ft.) - Diagram

← NORTH

Civic Functions

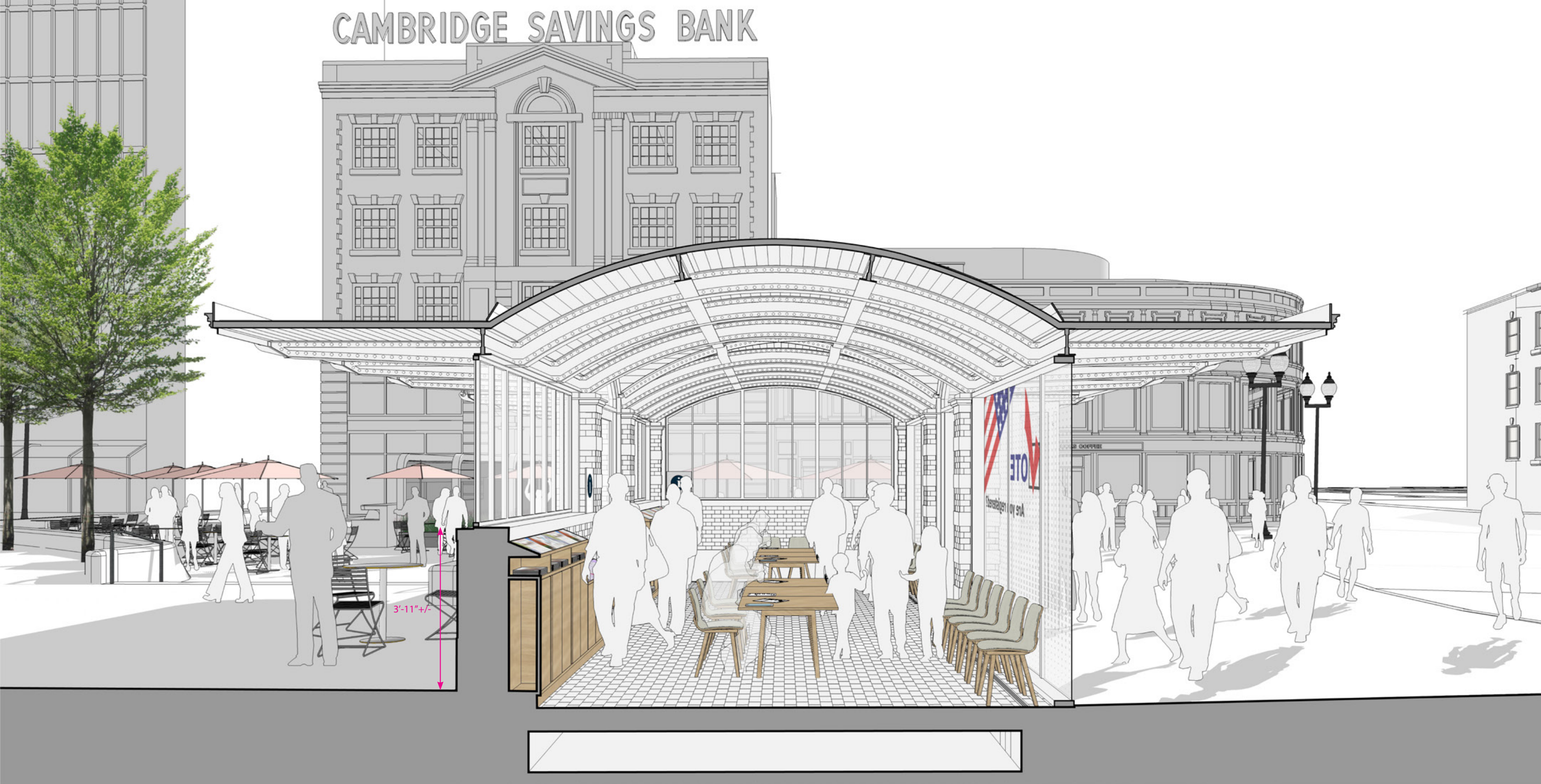

Section - East/West

Sliding Windows (Counter Height)

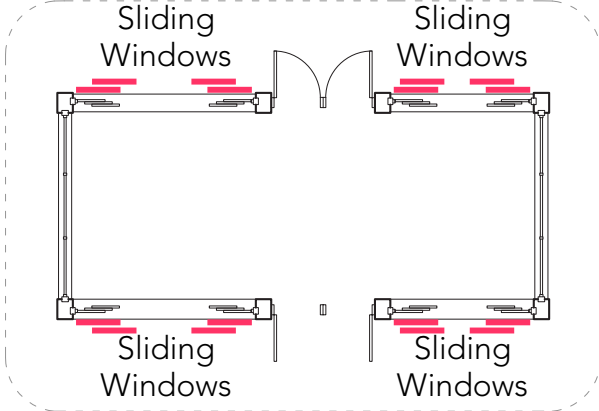

Key Plan



View - Southwest



View - Northeast

Social Seating

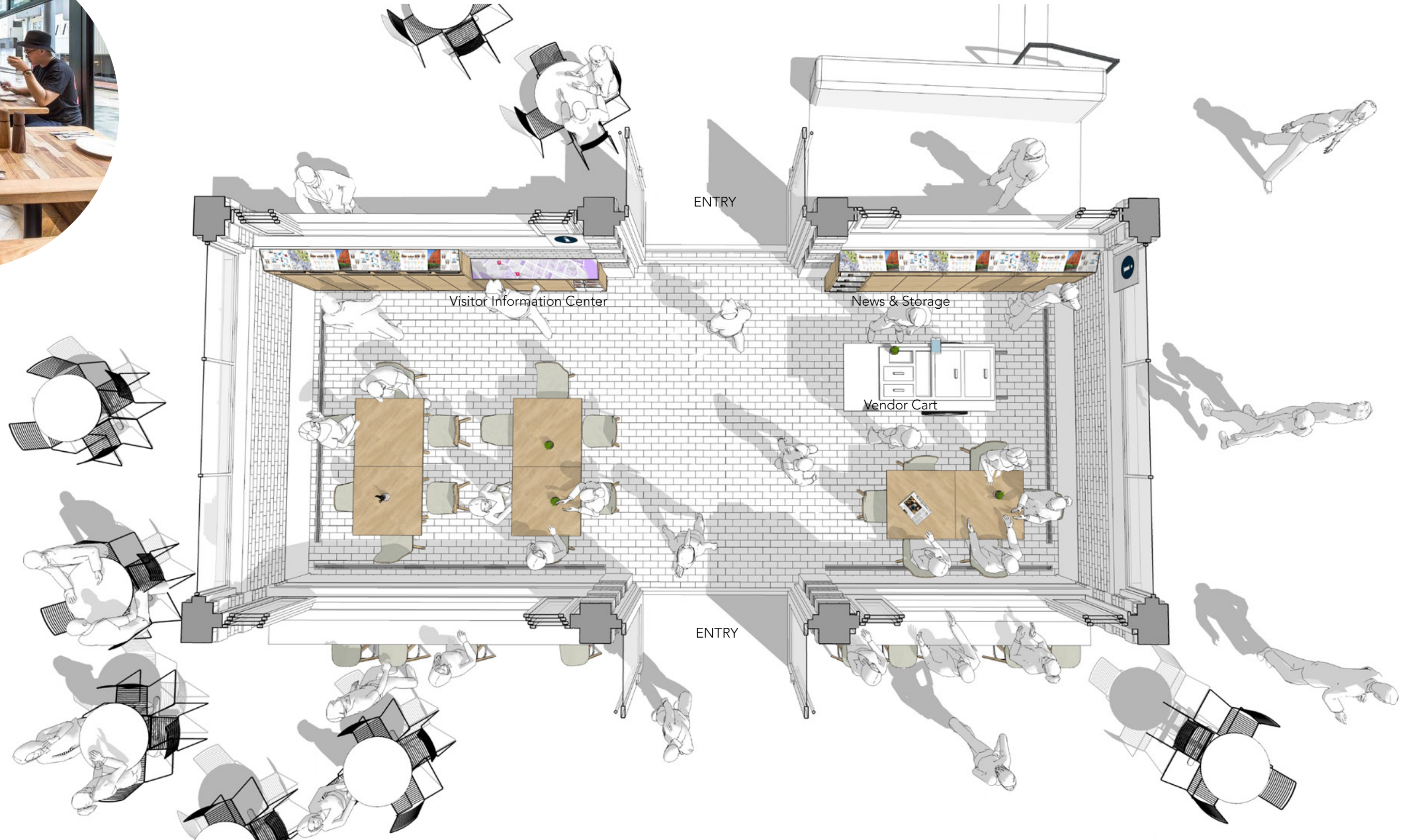

Plan (500 Sq.Ft.) - Diagram

← NORTH

Social Seating



Section - East/West

Historic Signage Photo - circa 1961



Historic Signage Orientation

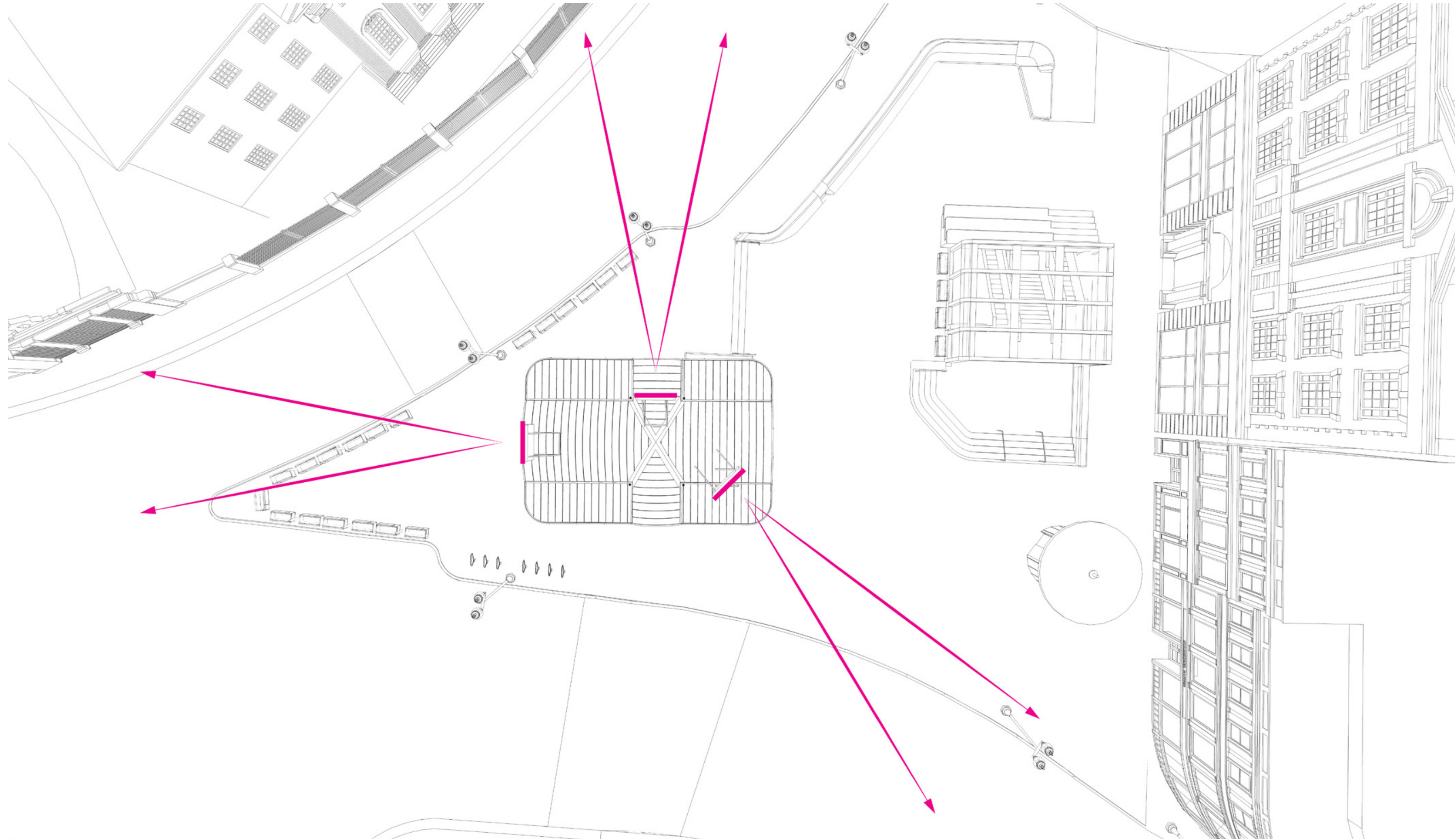

Sliding Windows (Counter Height)



View - Southwest



View - Northeast

HARVARD SQUARE - CAMBRIDGE, MASSACHUSETTS

APRIL 25, 2018

Digital Sign - Approach from Sidewalk



Folding Glass Doors

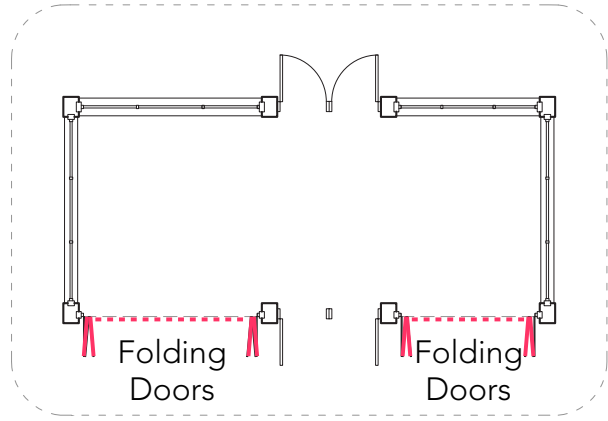

Key Plan



View - Southwest



View - Northeast

Board Games

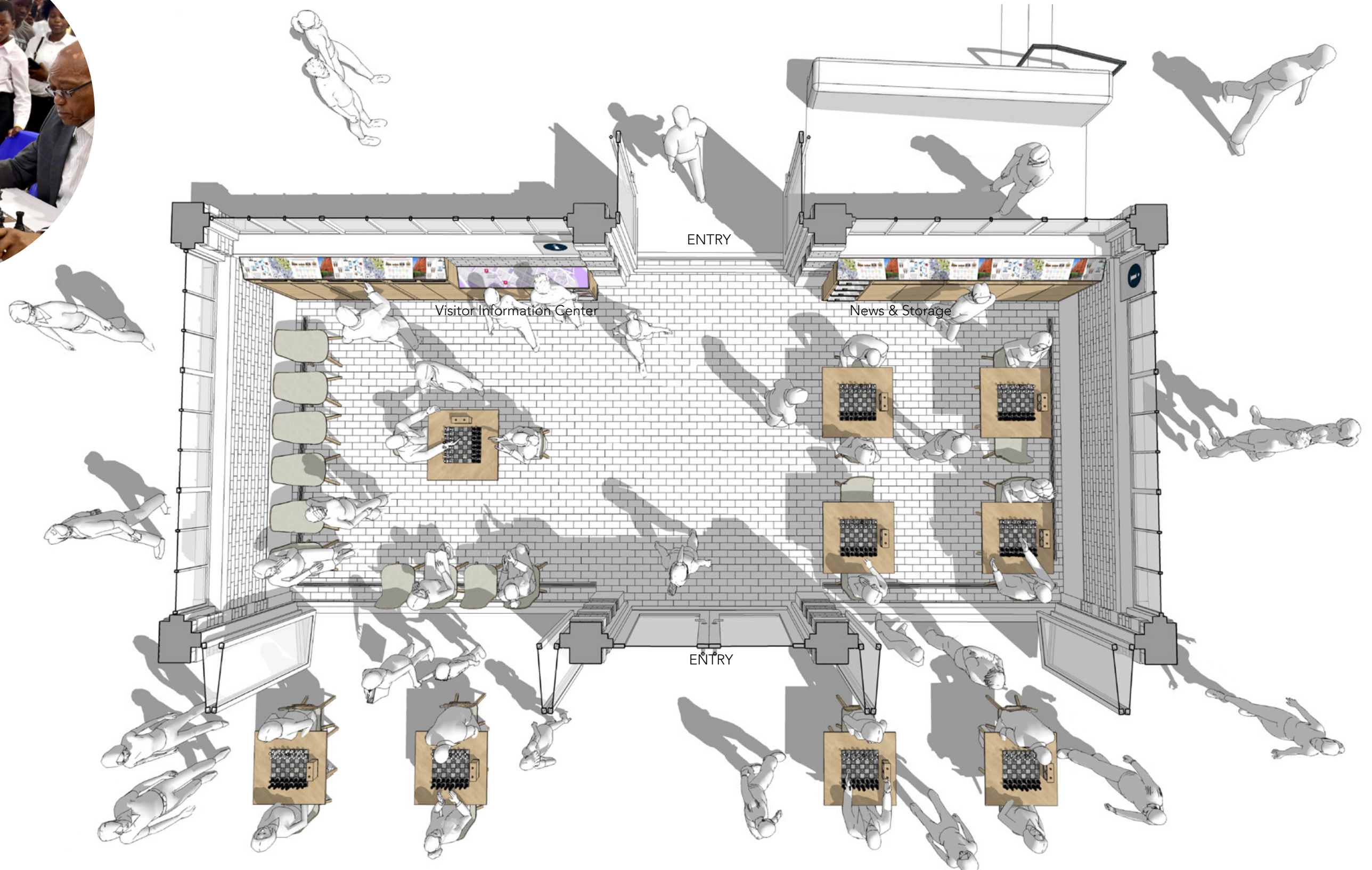

Plan (500 Sq.Ft.) - Diagram

← NORTH

Board Games

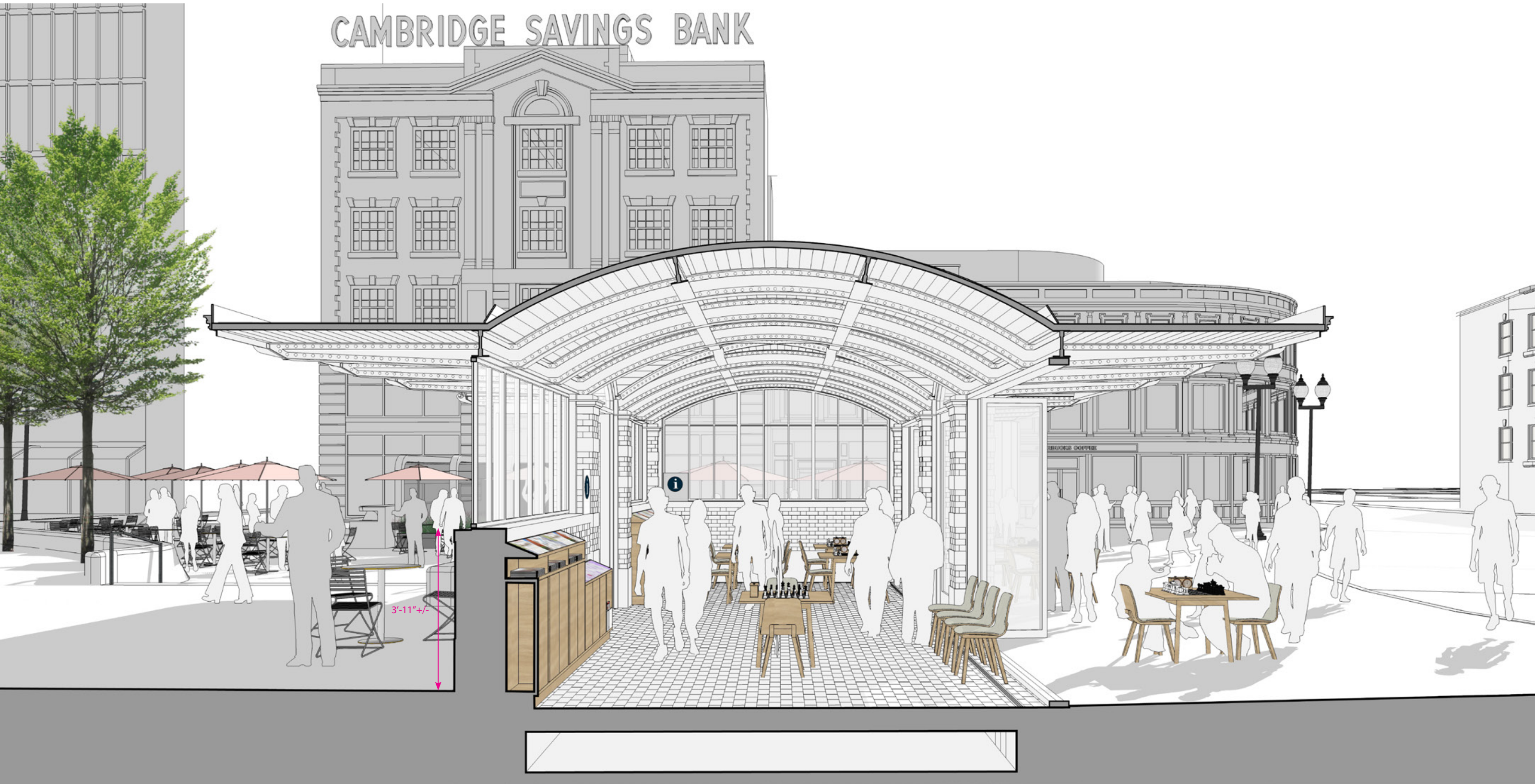

Section - East/West

Folding Glass Doors with Digital Windows

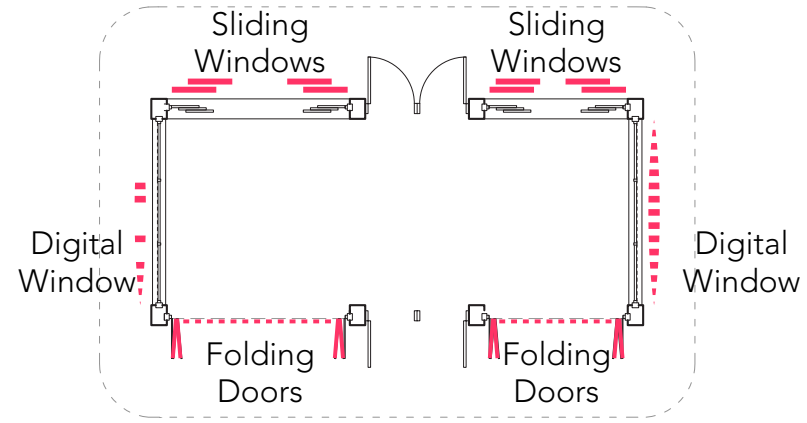

Key Plan



View - Southwest



View - Northeast

Performances/Events

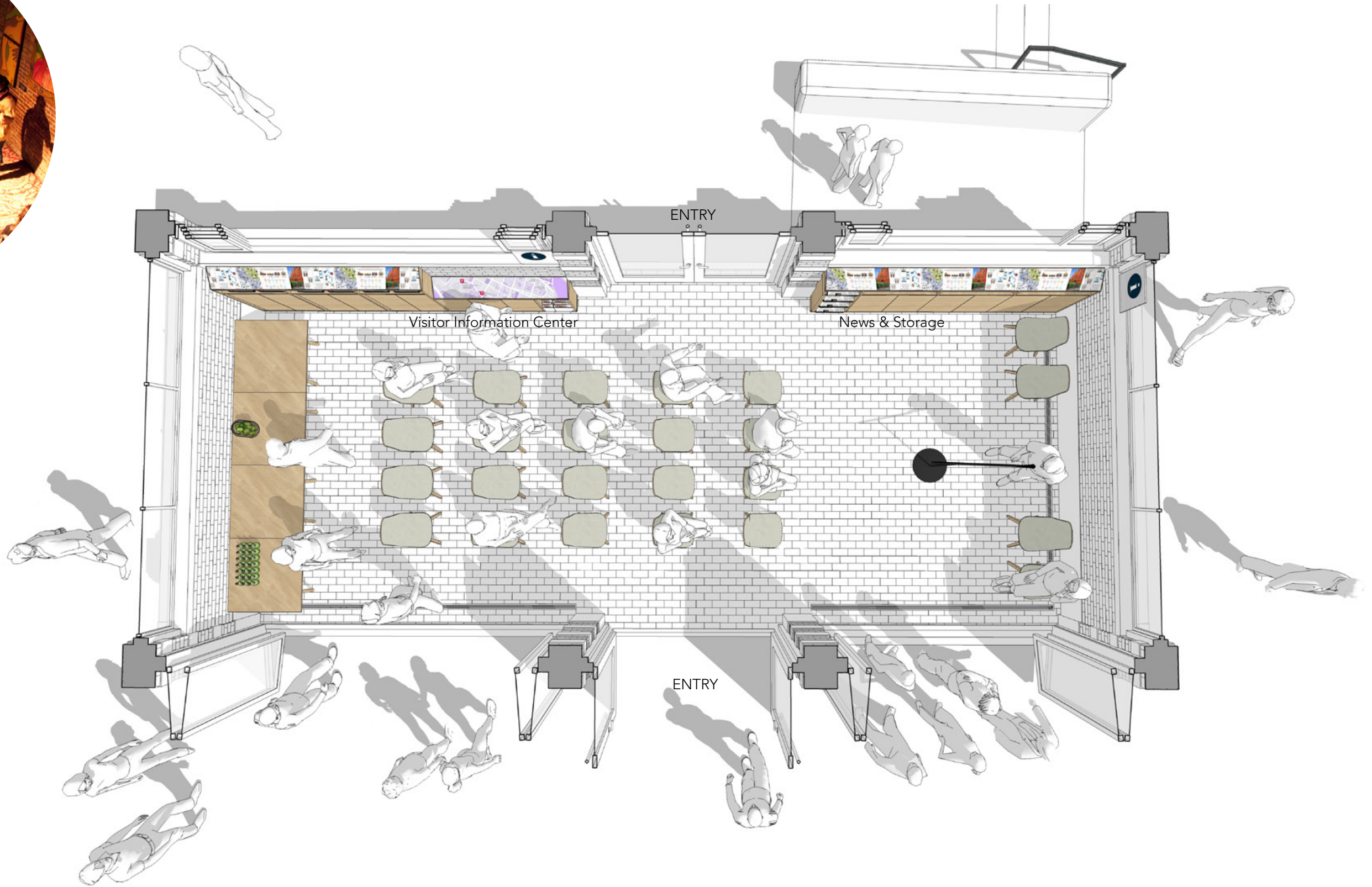

Plan (500 Sq.Ft.) - Diagram

← NORTH

Performances/Events



Section - East/West

Exterior Kiosk Opportunities



Fixed Windows



Fixed Digital Windows



Sliding Windows (Counter Height)



Family Activities



Civic Functions



Visitor Information



News



Social Seating



Board Games



Performance



Folding Glass Doors



Folding Glass Doors with Digital Windows

Character of the Place



Questions and Comments

Ways to share your feedback:

- Provide input on boards
- Fill out a comment card
- Email: dwolf@cambridgema.gov