



SOMA BUILDING 3

DESIGN REVIEW

PRESENTATION TO CAMBRIDGE
PLANNING BOARD

FEBRUARY 28, 2017



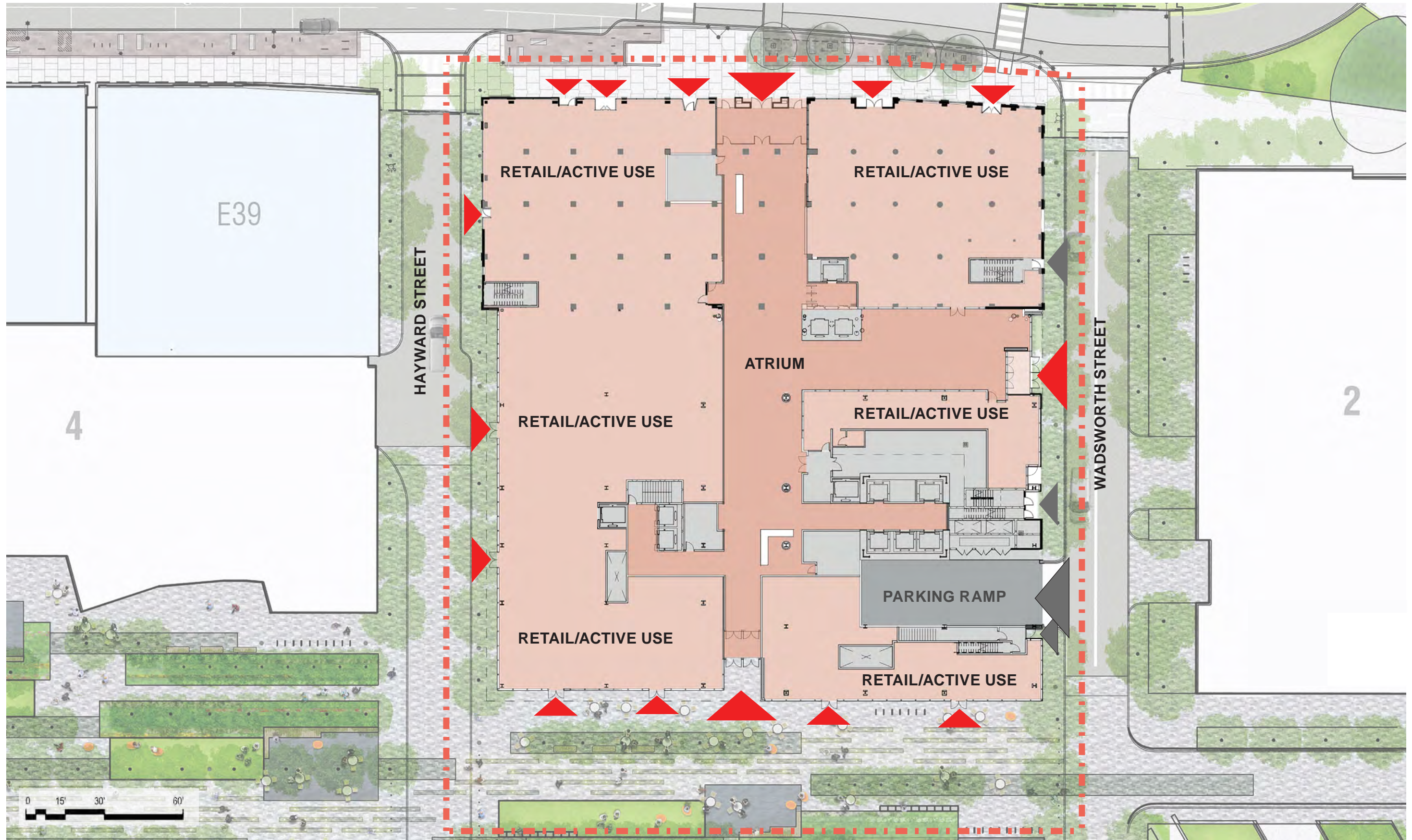

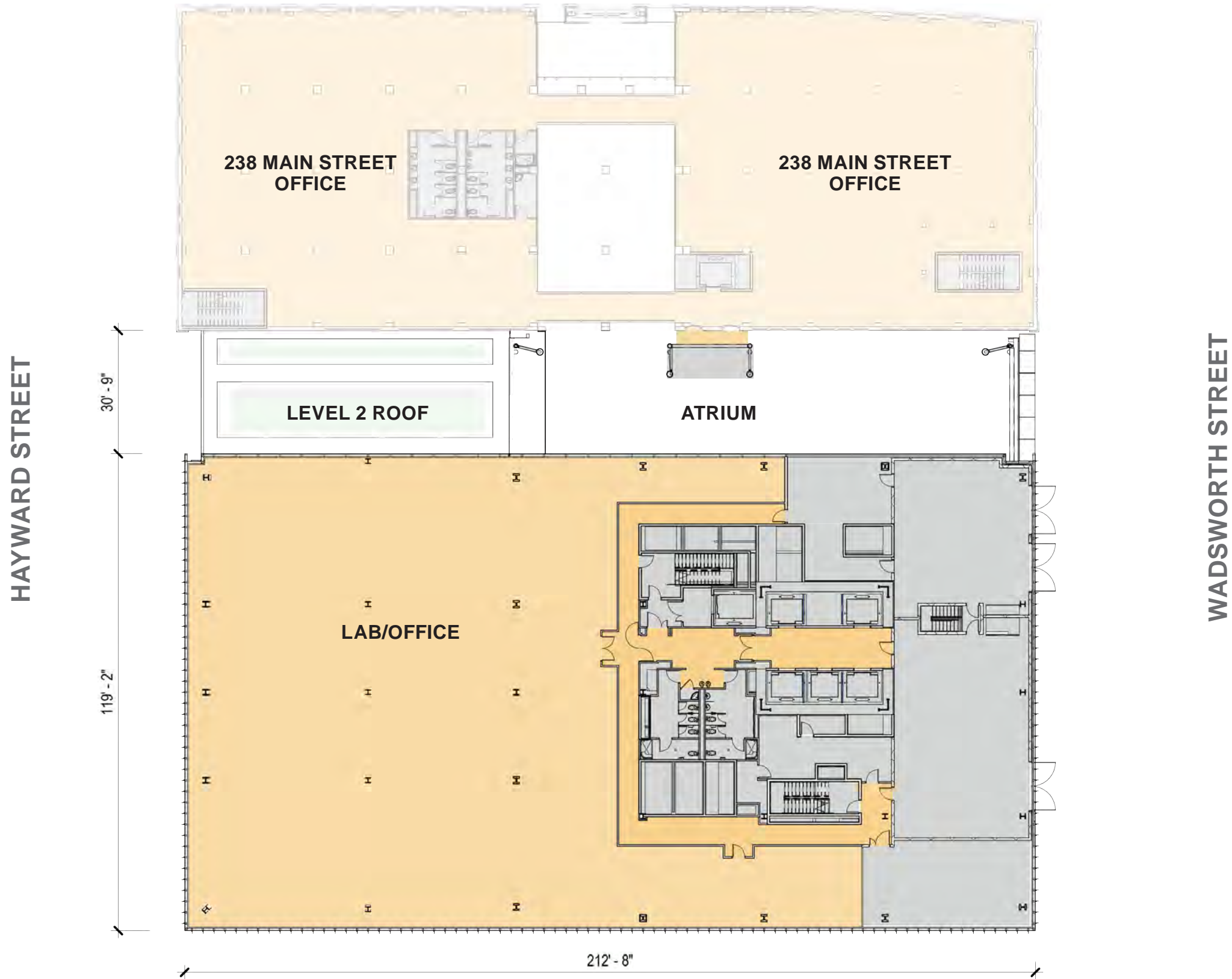

- RETAIL/ ACTIVE USE
- LAB/OFFICE COMMON SPACE
- LAB/OFFICE
- SERVICE/ MECHANICAL
- PARKING



LEVEL 2 FLOOR PLAN

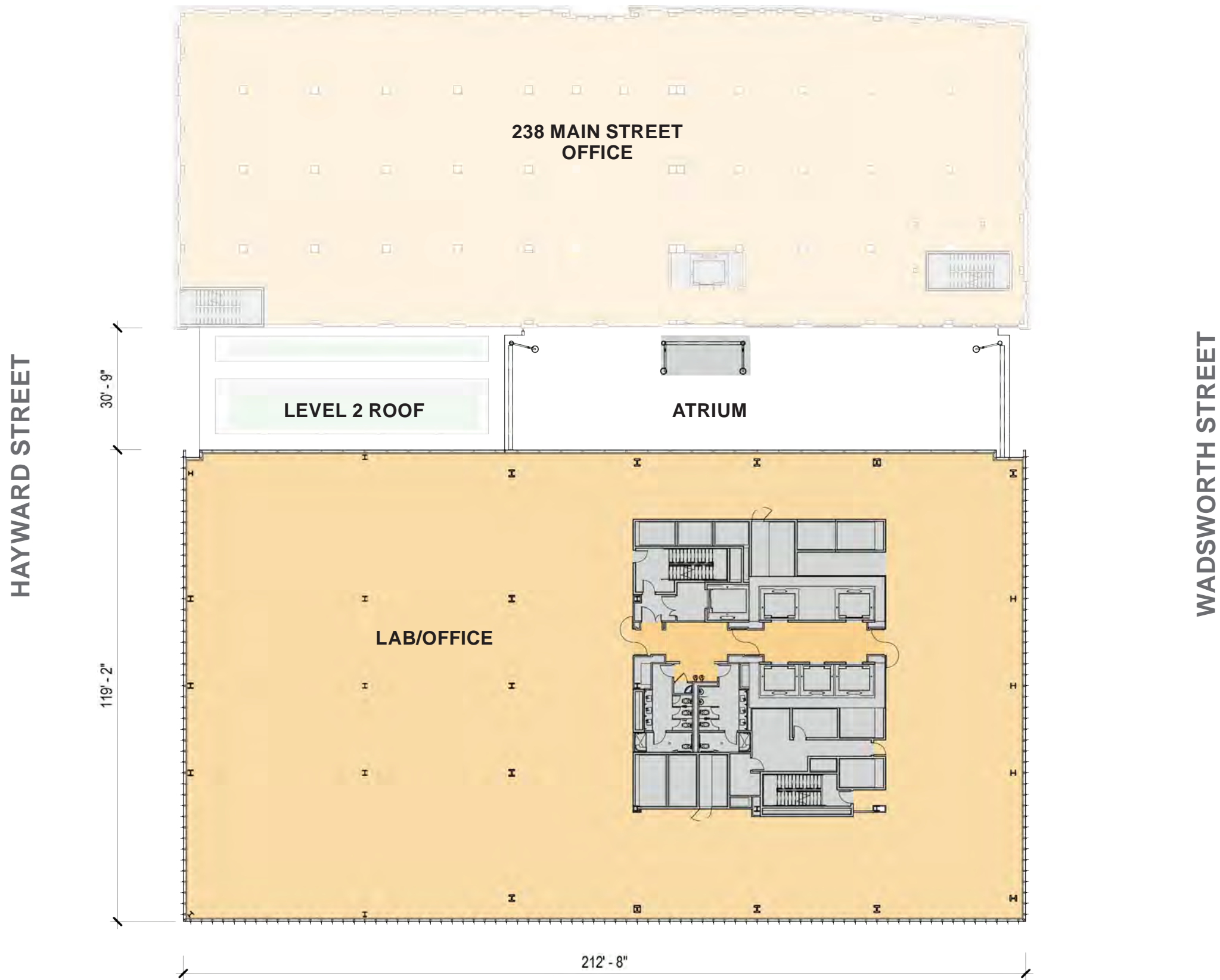

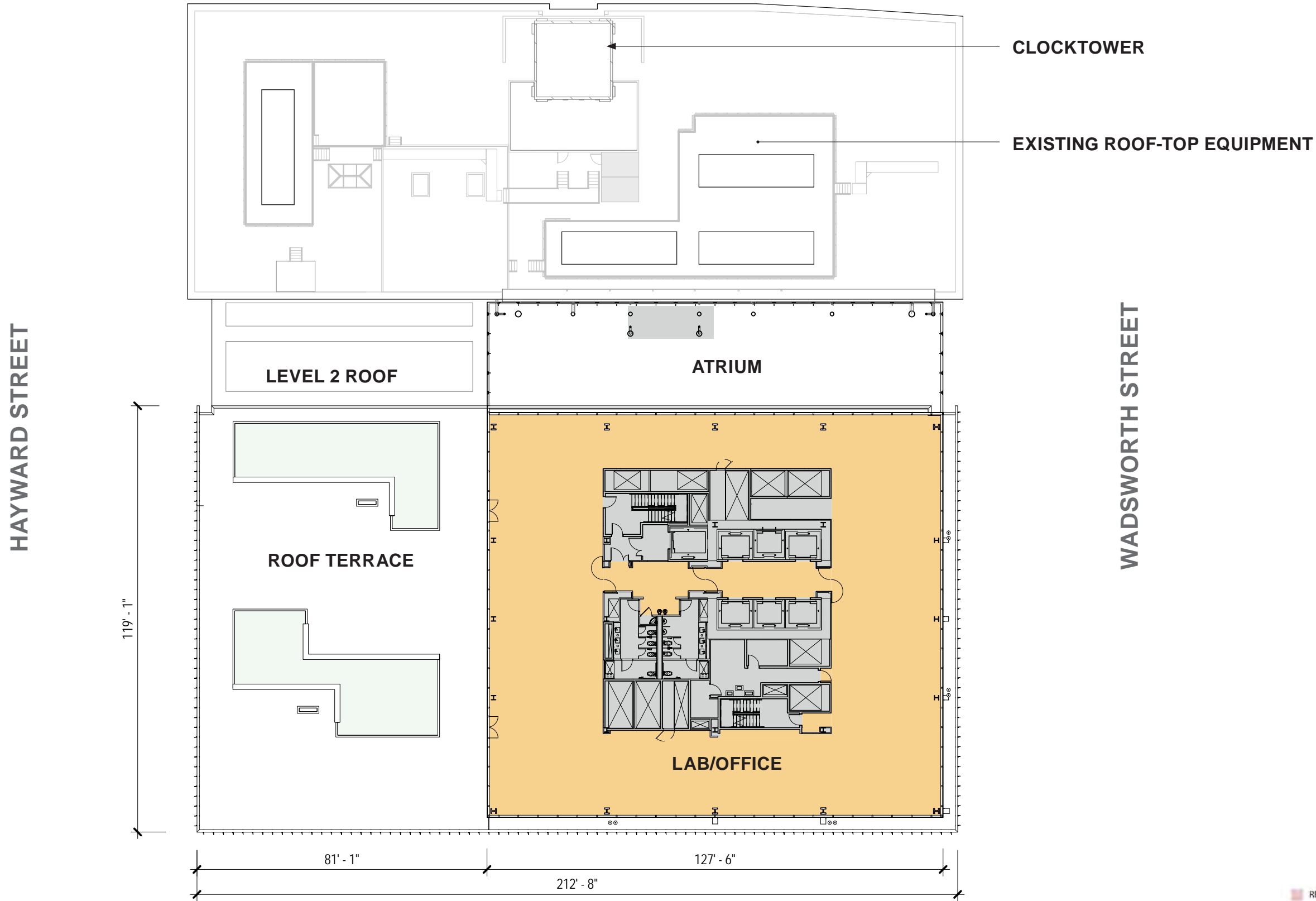

- RETAIL/ ACTIVE USE
- LAB/OFFICE COMMON SPACE
- LAB/OFFICE
- SERVICE/ MECHANICAL
- PARKING



LEVEL 6 FLOOR PLAN

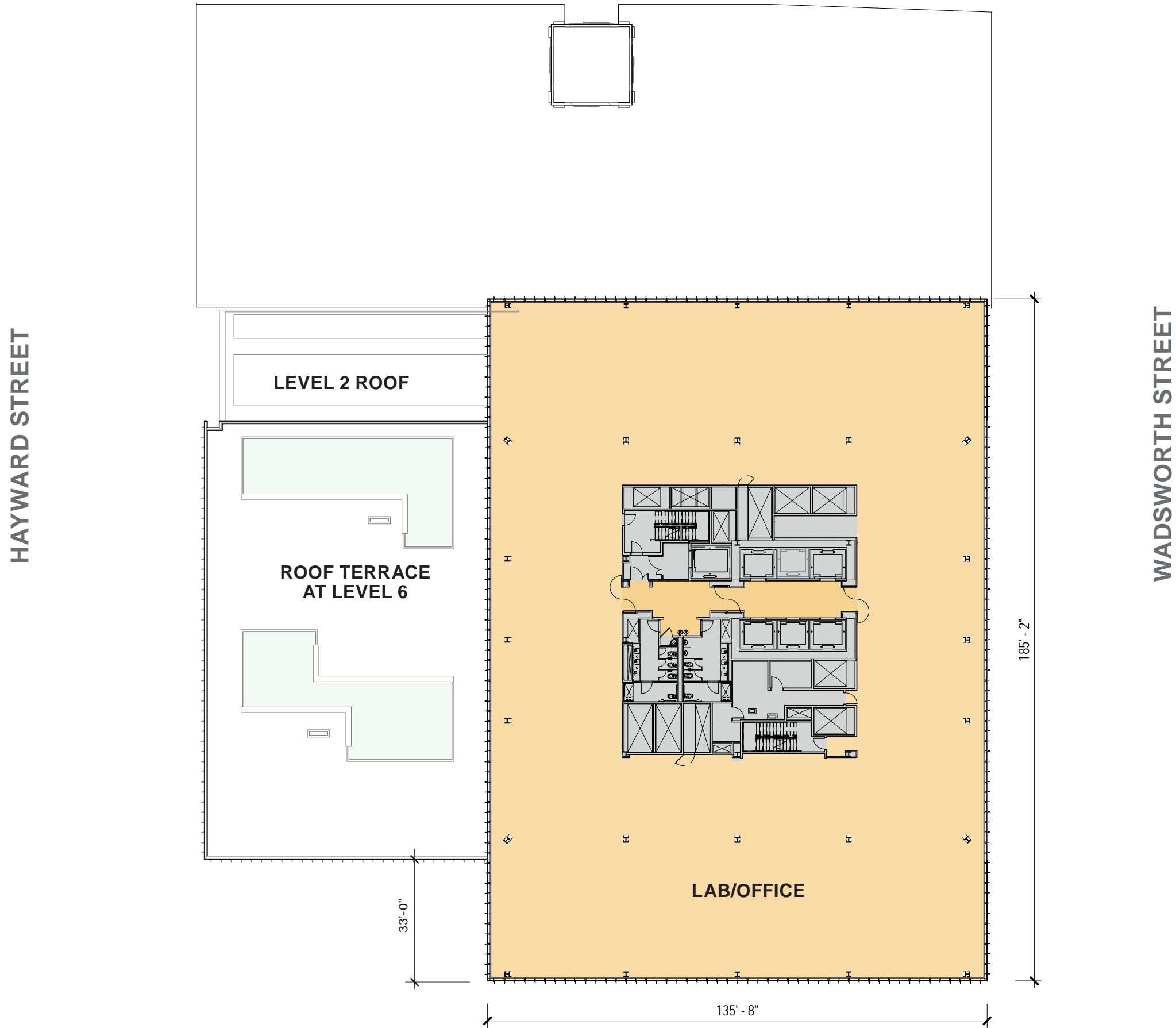

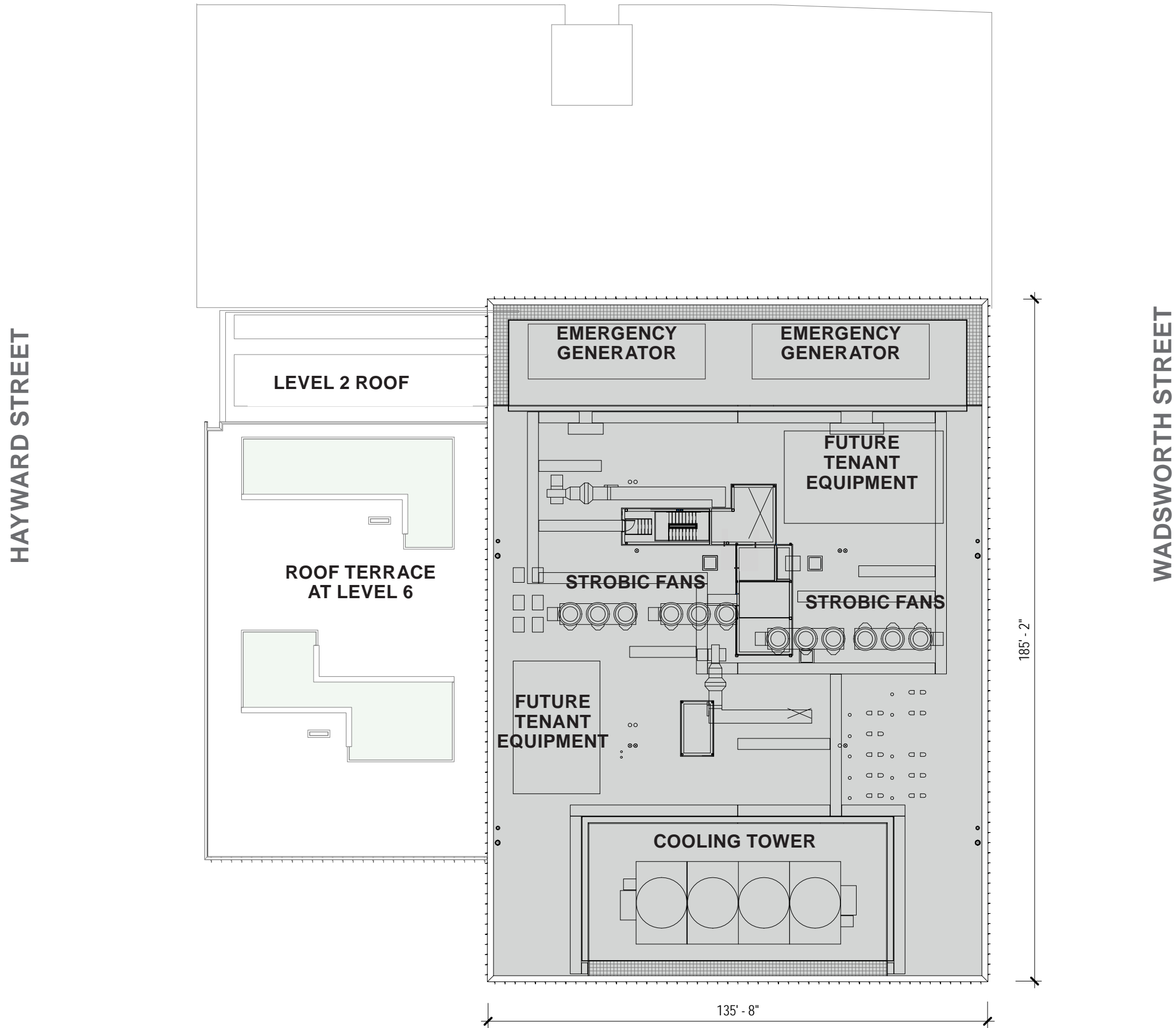

- RETAIL/ ACTIVE USE
- LAB/OFFICE COMMON SPACE
- LAB/OFFICE
- SERVICE/ MECHANICAL
- PARKING



ROOF PLAN

- RETAIL / ACTIVE USE
- LAB/OFFICE COMMON SPACE
- LAB/OFFICE
- SERVICE / MECHANICAL
- PARKING

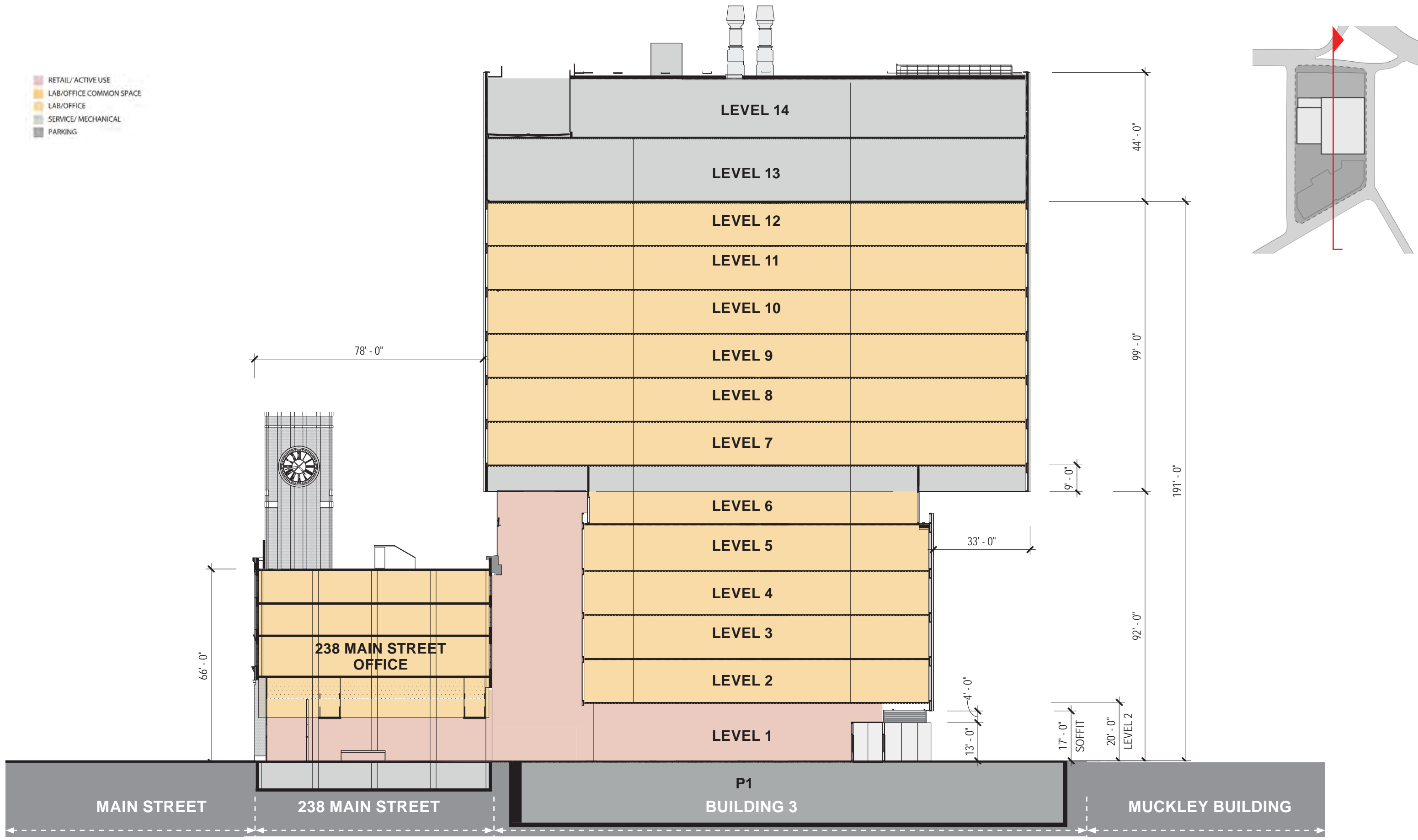

BUILDING SECTION

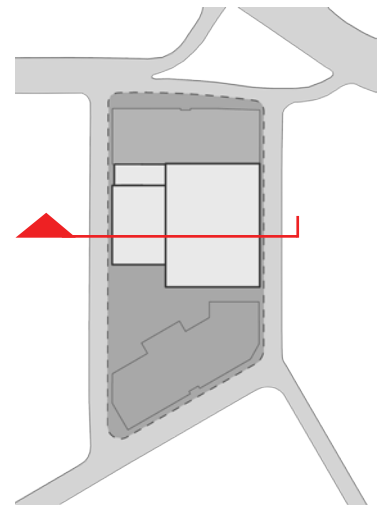
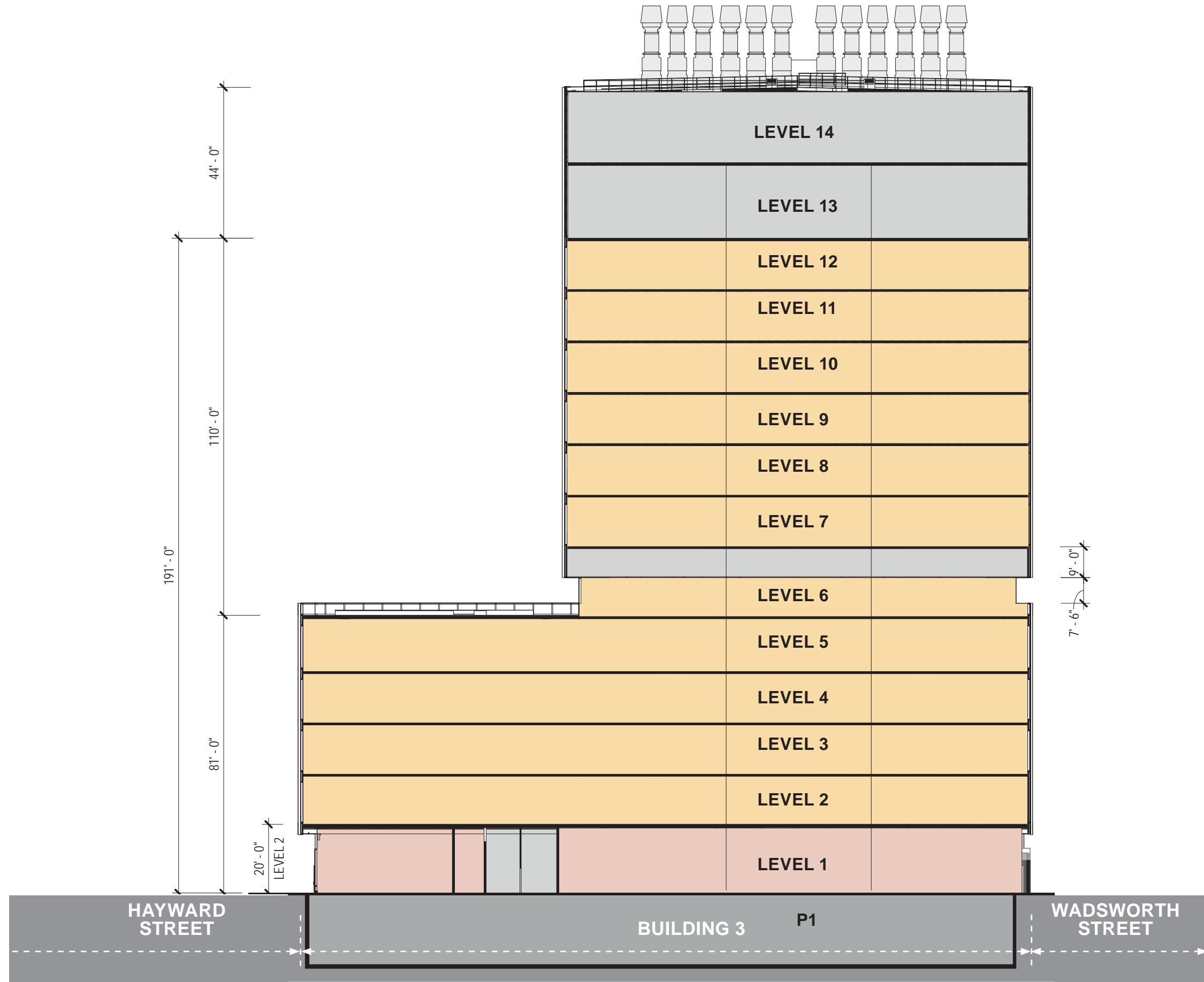

BUILDING SECTION

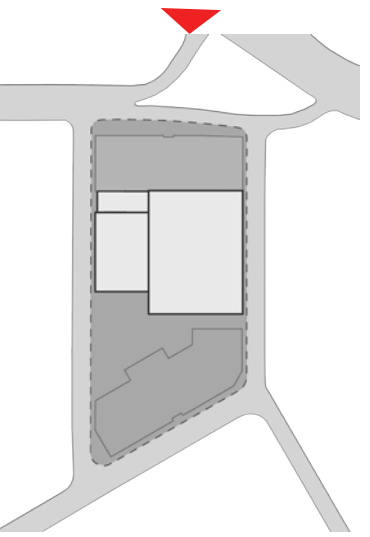

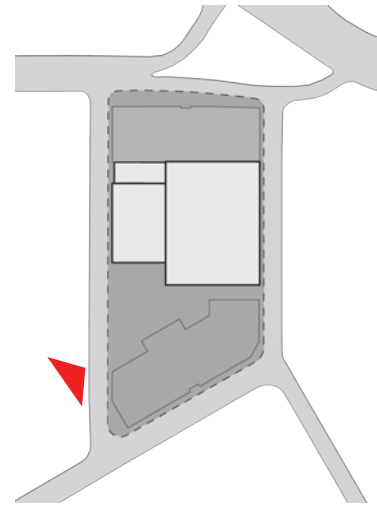

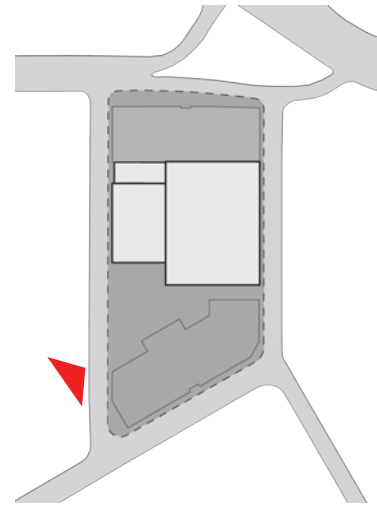

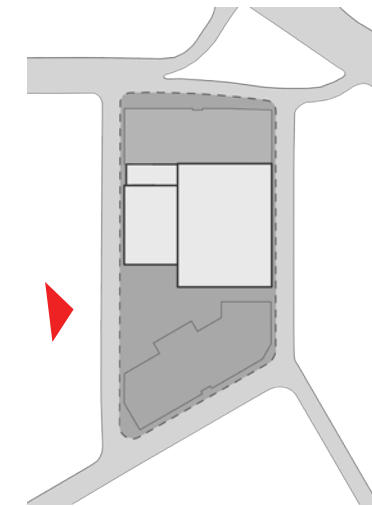



238 MAIN STREET, MAIN STREET FACADE



238 MAIN STREET, HAYWARD STREET LOOKING NORTH

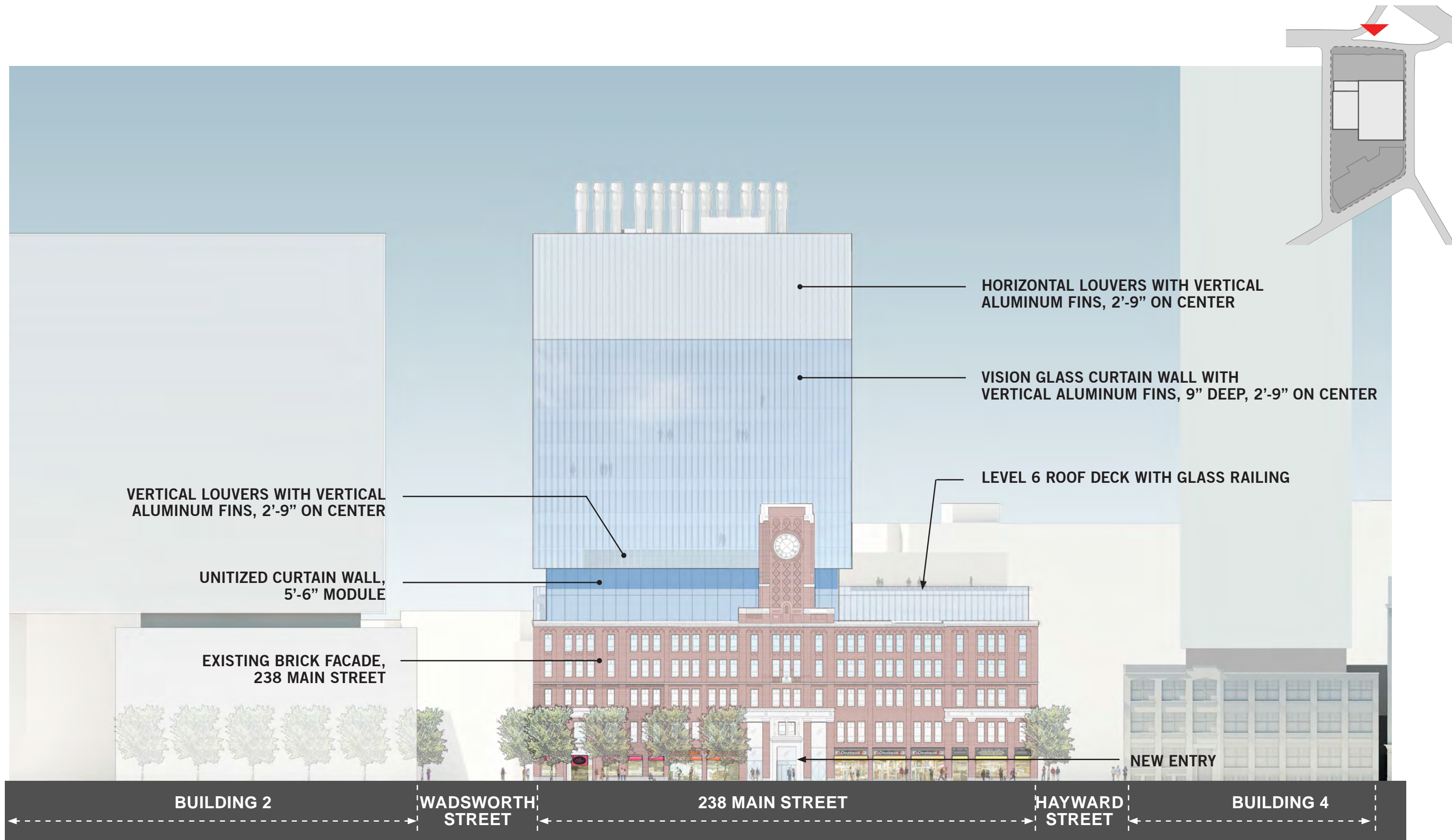

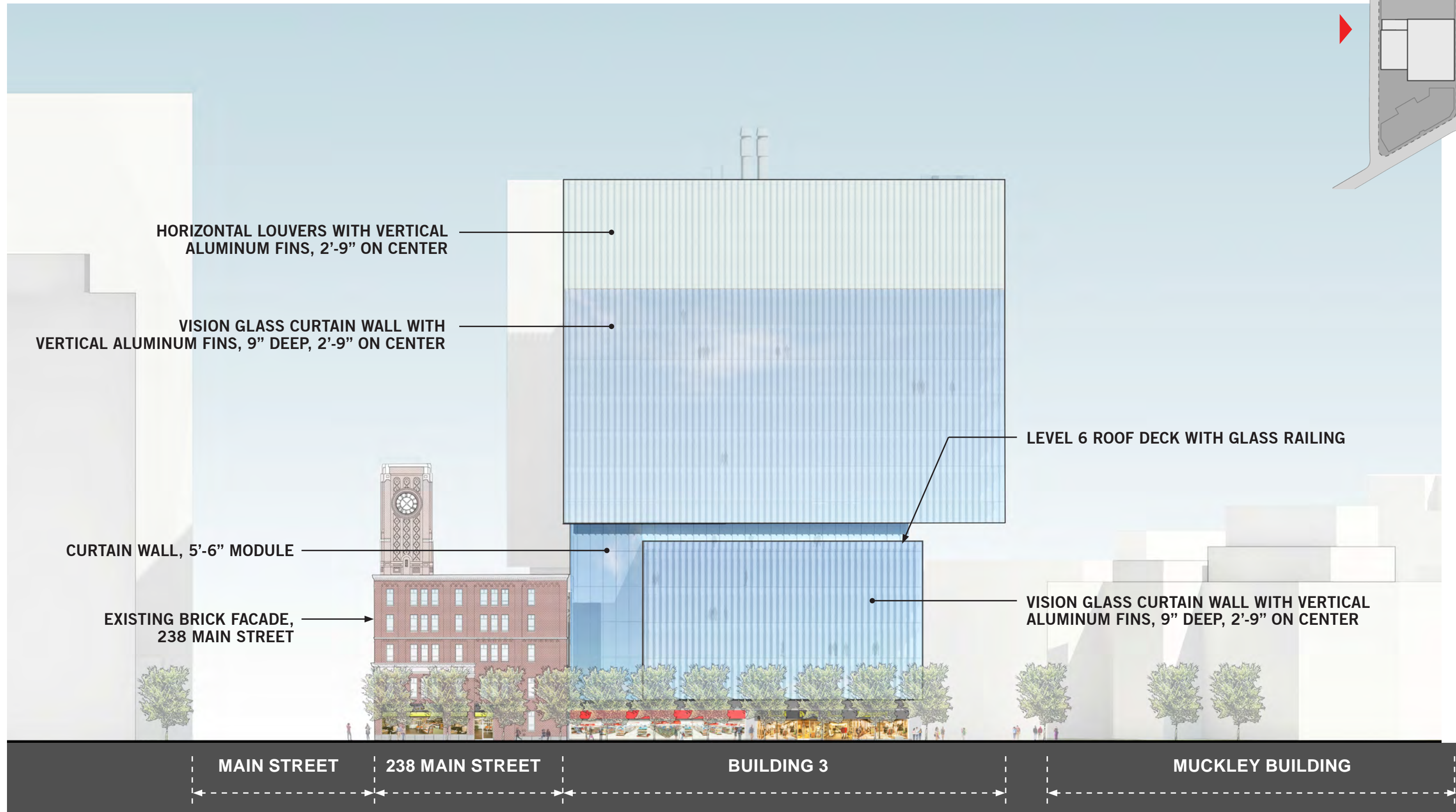
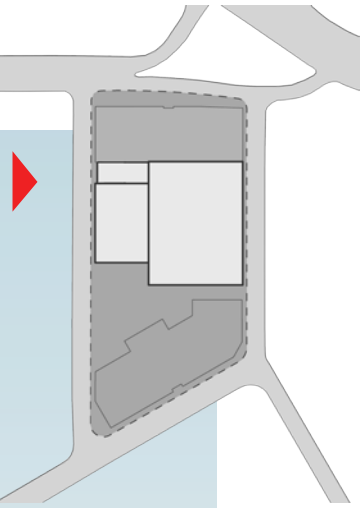

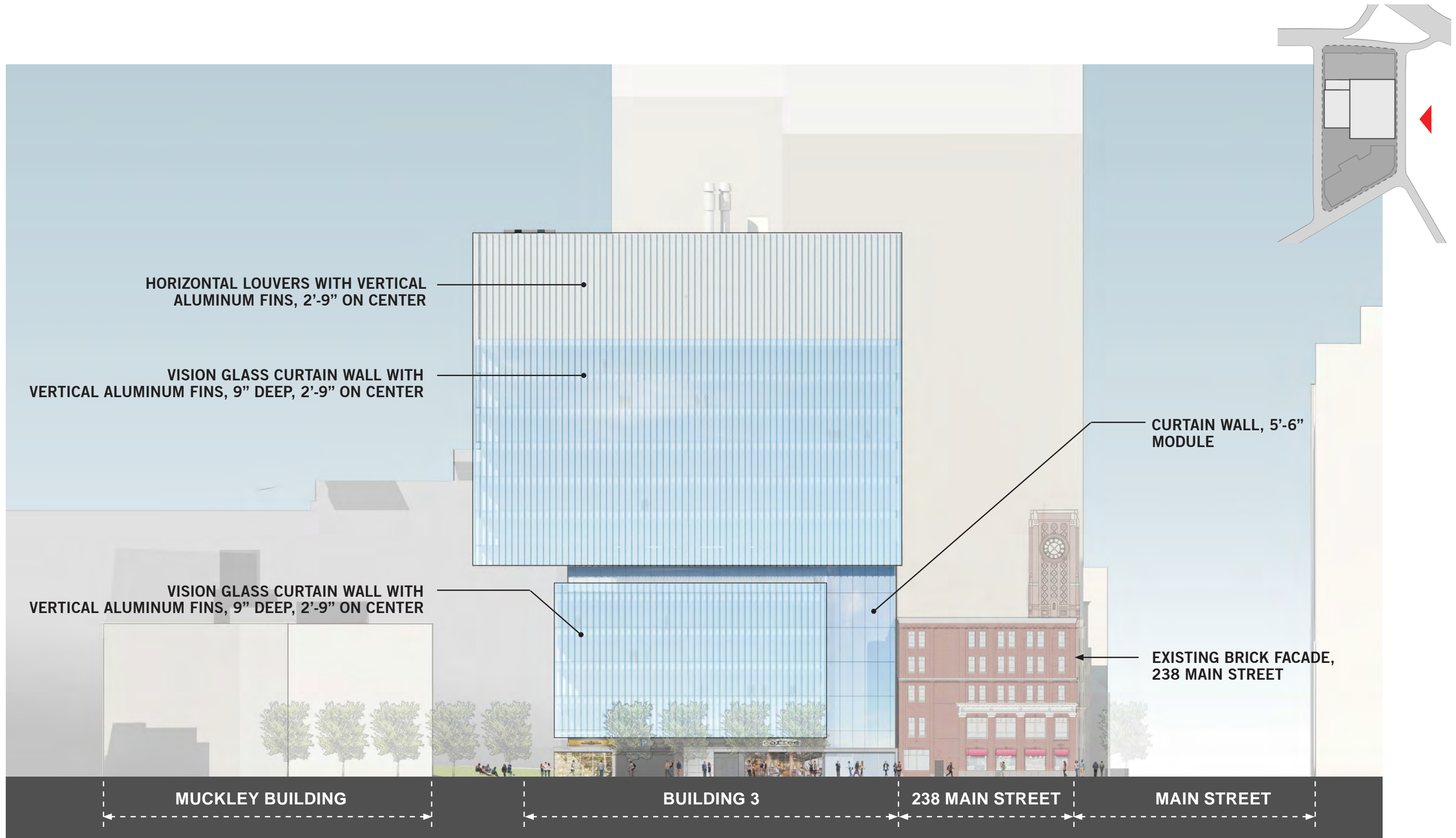

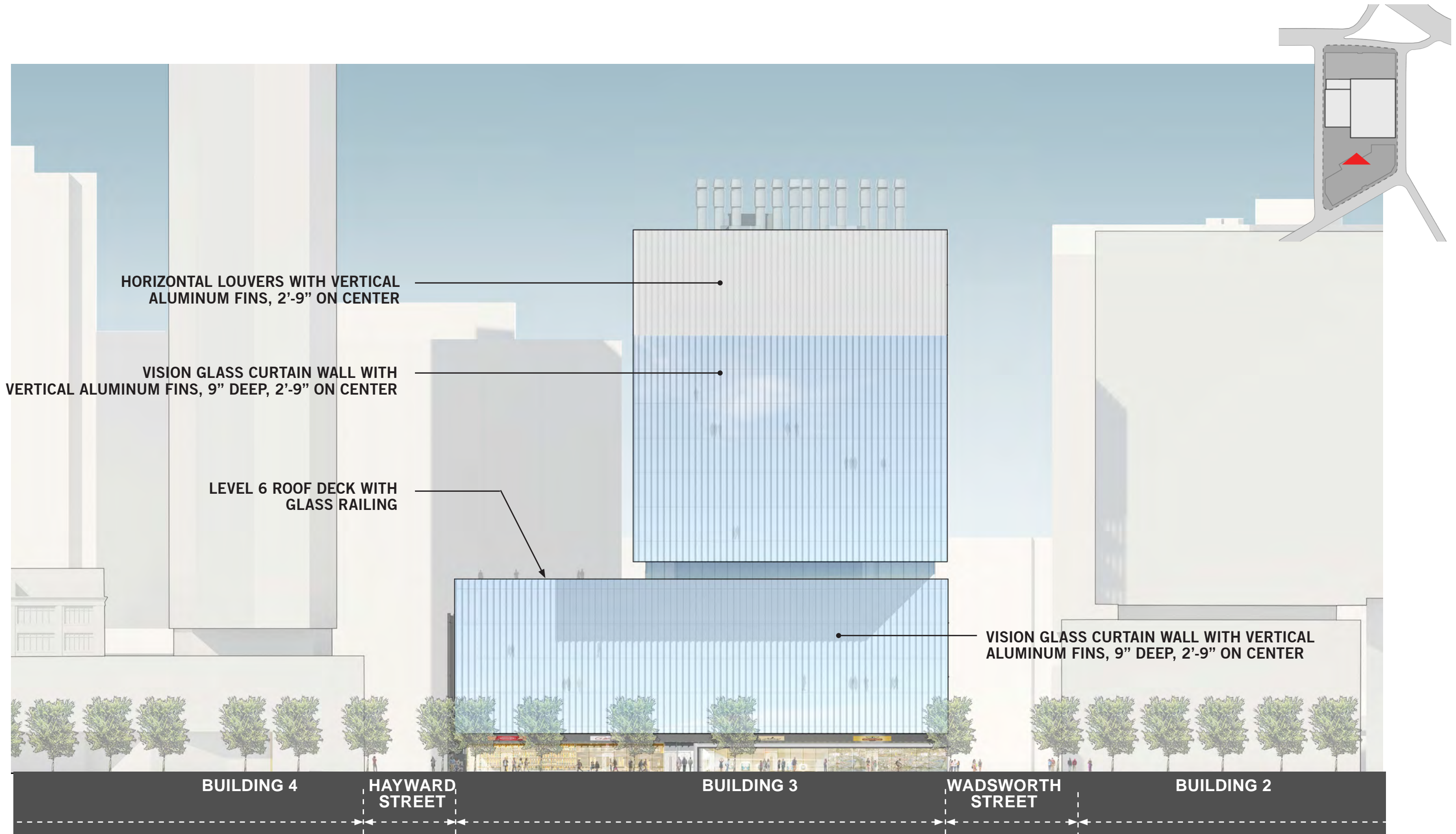



DETAIL AREA

CURTAIN WALL WITH
ALUMINUM MULLIONS, 9" DEEP, 2'-9" ON CENTER

WHITE ALUMINUM PANEL

ALUMINUM MULLION, 9" DEEP, 2'-9" ON CENTER

HORIZONTAL ALUMINUM LOUVER

VISION GLASS CURTAIN WALL WITH
VERTICAL ALUMINUM FINNS, 9" DEEP, 2'-9" ON CENTER

REFLECTIVE VISION GLASS

GLASS SHADOWBOX WITH VERTICAL ALUMINUM FINNS AT
2'-9" ON CENTER

DETAIL AREA

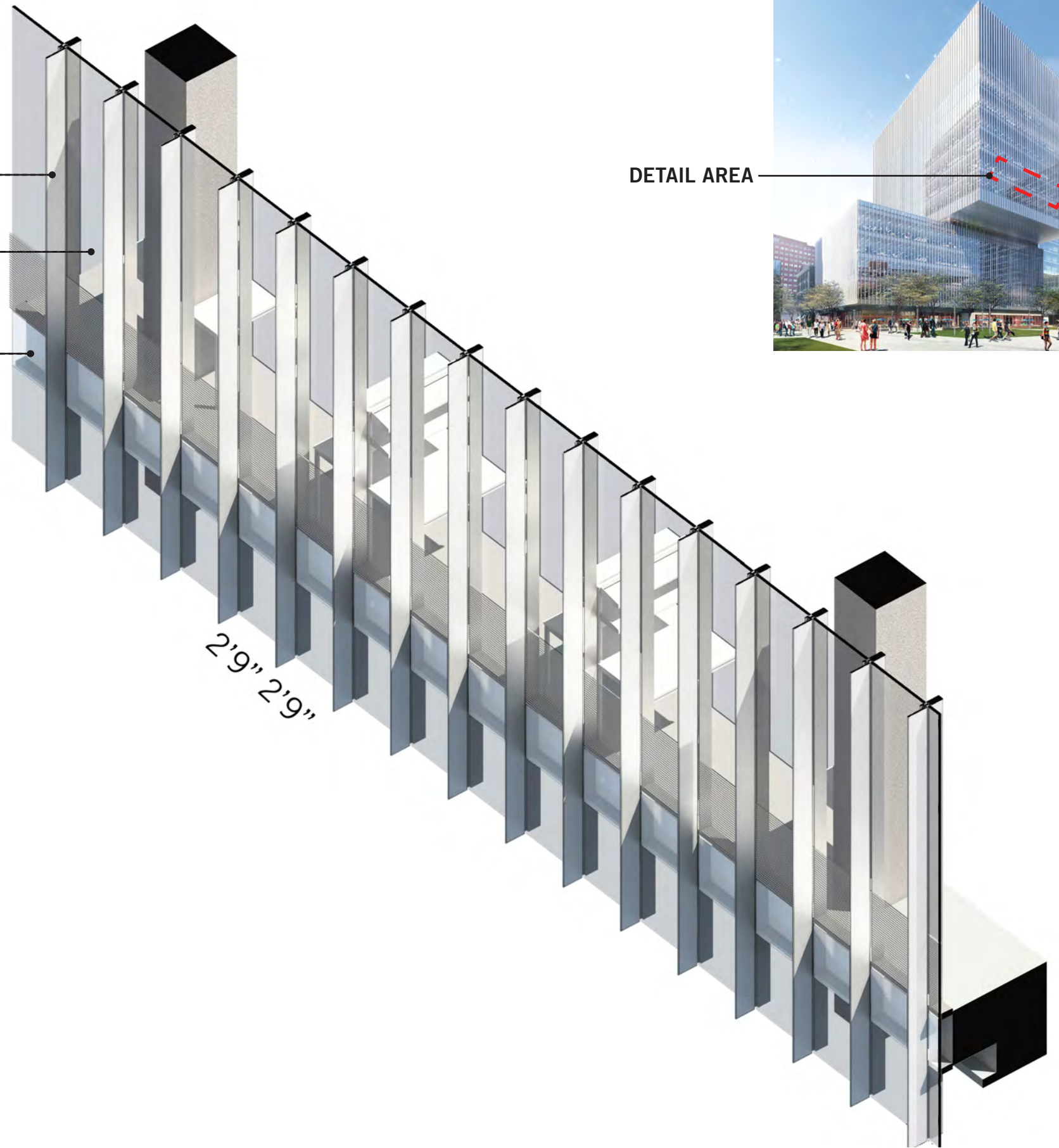

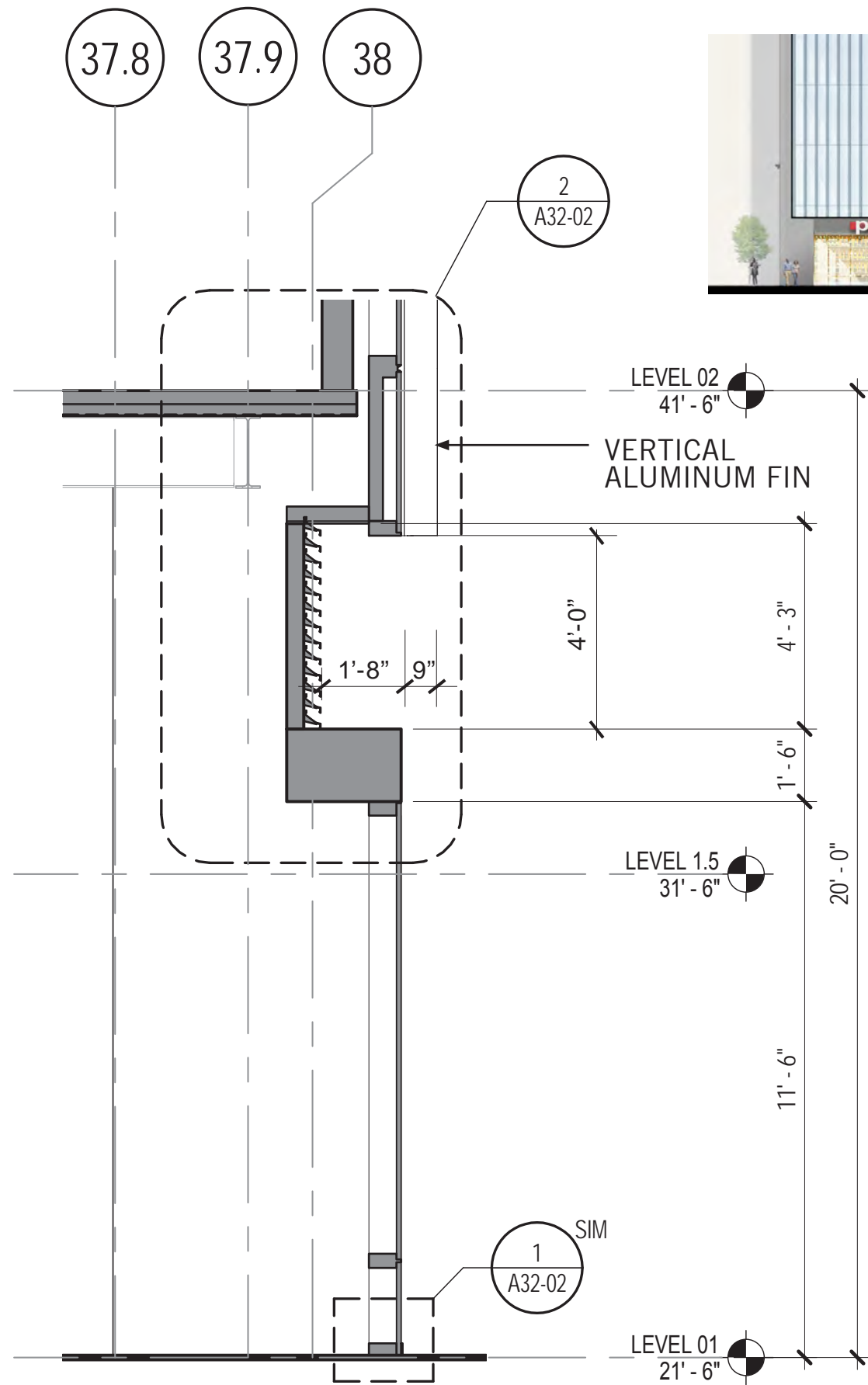

SOUTH ELEVATION

LEVEL 1 EXTERIOR WALL SECTION

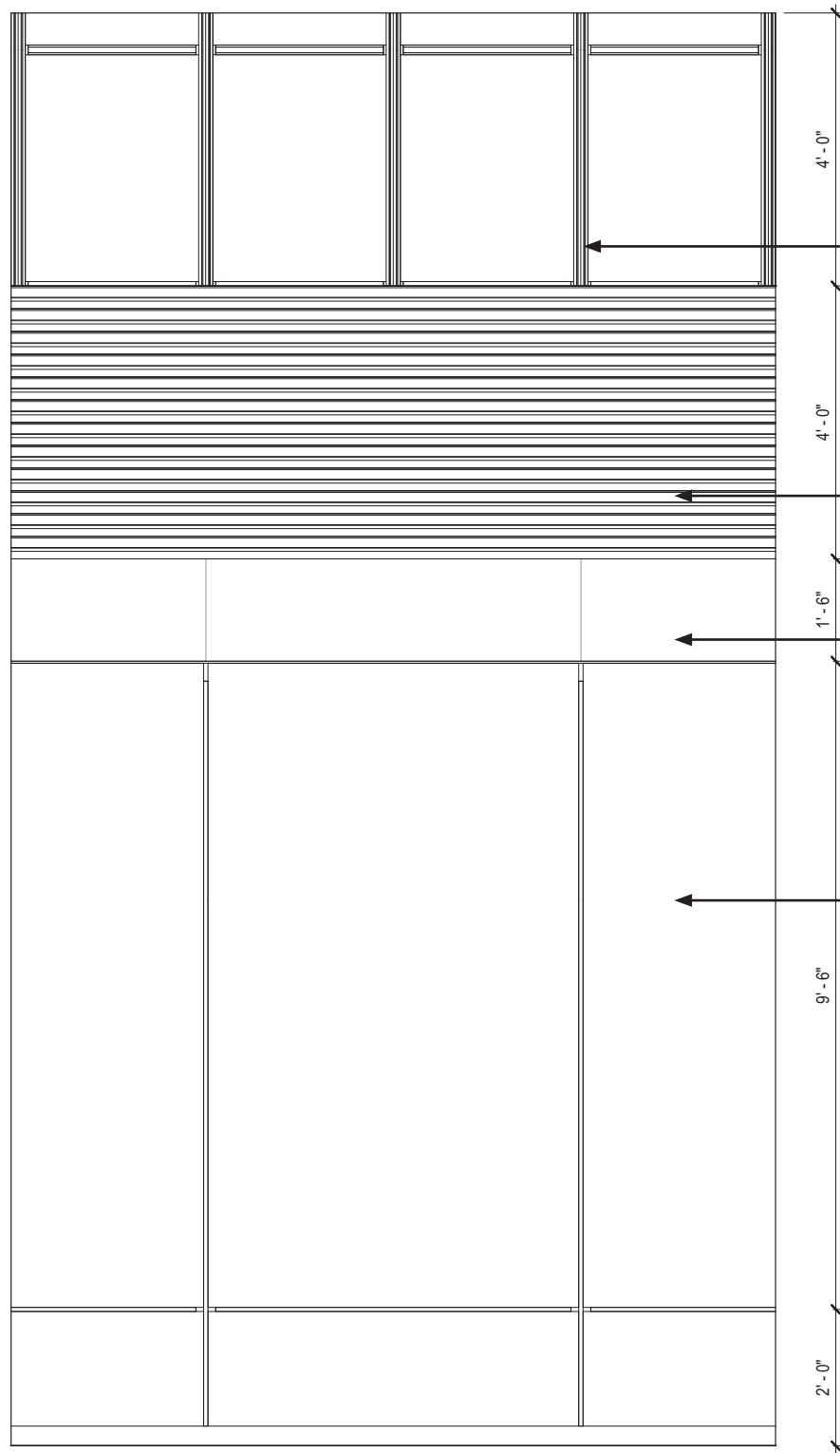

1. ELEVATION OF LEVEL 1 SOFFIT CONDITION

VERTICAL ALUMINUM FIN

FIXED EXTRUDED ALUMINUM LOUVER

ALUMINUM PLATE WALL PANEL

ALUMINUM-FRAMED STOREFRONT WALL

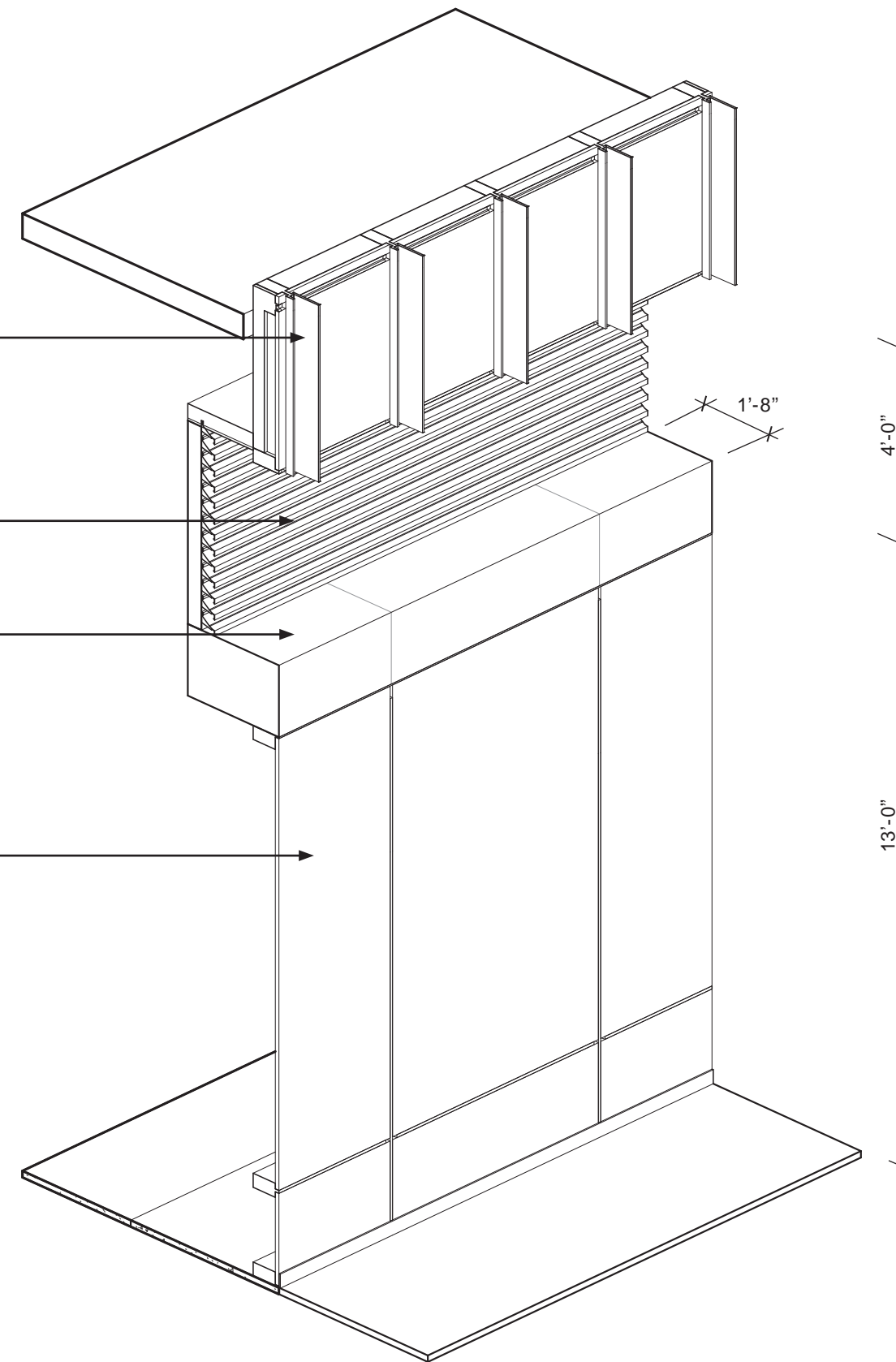

2. SOFFIT CONDITION



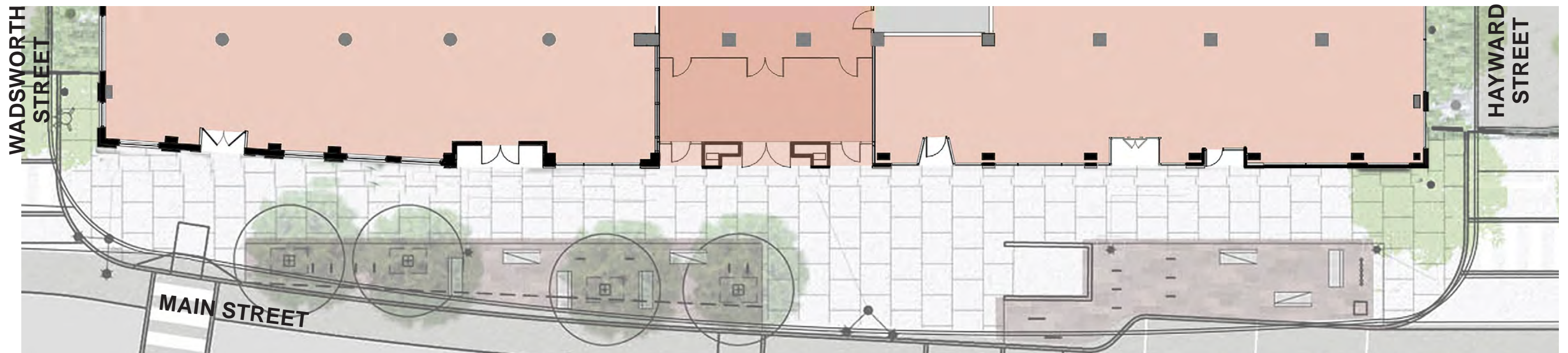



- BRONZE LETTERING
- BLACK METAL PANEL
- WHITE PAINTED TRIM
- GREEN MARBLE SURROUND
- BRONZE -COLORED STOREFRONT
- GRAY GRANITE BASE

10 1/2" 6'-7" 10 1/2"
 6'-8" DOOR
 DOOR

**238 MAIN STREET
PROPOSED MAIN STREET ELEVATION**



