

18-26 CHAUNCY STREET, CAMBRIDGE

SPECIAL PERMIT COVER SHEET

Project Location: 18-26 Chauncy Street

Zoning District: C-2 & A-1

Owner: Chauncy Court LLC
c/o Chestnut Hill Realty
300 Independence Drive
Chestnut Hill, MA 02467

Project: CHR is proposing to add 9 apartments at the basement level pursuant to the Basement Apartment Overlay District, Cambridge Zoning Ordinance 20.600 (the "Project").

Special Permits: 20.600- Basement Apartment Overlay District, Cambridge Zoning Ordinance (as amended)

6.35.1 Reduction of Required Parking

6.106 Access Standards for Bicycle Parking



18-26 Chancy Street, Cambridge

Special Permit Application

Table Contents

Application

Special Permit Summary

Locus Map

Transportation Memo

Community Outreach

Existing Exterior Photos

 Front of Building Photos

 Back of Building Photos

Existing Interior Photos

Existing Neighborhood Photos

Floor Plans

 Existing Conditions

 Proposed Conditions

Civil Engineering Plans

 Existing Conditions and Proposed Conditions

 Details

Plumbing Plans

 P1

 P2



CITY OF CAMBRIDGE, MASSACHUSETTS

PLANNING BOARD

CITY HALL ANNEX, 344 BROADWAY, CAMBRIDGE, MA 02139

SPECIAL PERMIT APPLICATION • COVER SHEET

In accordance with the requirements of the City of Cambridge Zoning Ordinance, the undersigned hereby petitions the Planning Board for one or more Special Permits for the premises indicated below.

Location of Premises: 18-26 Chauncy Street

Zoning District: C-2 & A-1

Applicant Name: Chauncy Court LLC

Applicant Address: c/o Chestnut Hill Realty

Contact Information: 617/323-8800 mzucker@chestnuthillrealty.com 617/323-8801
Telephone # Email Address Fax #

List all requested special permit(s) (with reference to zoning section numbers) below. *Note that the Applicant is responsible for seeking all necessary special permits for the project. A special permit cannot be granted if it is not specifically requested in the Application.*

20.600 Basement Apartment Overlay District; 6.35 Parking Sp. Permit;
6.106 Access Standards for Bicycle

List all submitted materials (include document titles and volume numbers where applicable) below.

SP Project Overview, Civil Engineering Plans, Architect Plans, Plumbing Plans

Signature of Applicant: _____

For the Planning Board, this application has been received by the Community Development Department (CDD) on the date specified below:

_____ Date

_____ Signature of CDD Staff

OWNERSHIP CERTIFICATE

Project Address: 18-26 Chauncy Street

Application Date: 1/ 20 /2016

This form is to be completed by the property owner, signed, and submitted with the Special Permit Application:

I hereby authorize the following Applicant: Chestnut Hill Realty
at the following address: 300 Independence Dr. Chestnut Hill
to apply for a special permit for: 20.600 Basement Apartment Overlay
on premises located at: 18-26 Chauncy
for which the record title stands in the name of: Chauncy Court LLC
whose address is: 300 Independence Drive Chestnut Hill, MA 02

by a deed duly recorded in the:

Registry of Deeds of County: Middlesex S₂ Book: 35600 Page: 150

OR Registry District of the Land Court,
Certificate No.: _____ Book: _____ Page: _____

P. Poras treas.

Signature of Land Owner (If authorized Trustee, Officer or Agent, so identify)

Peter F. Poras Treasurer of Management

To be completed by Notary Public:

Commonwealth of Massachusetts, County of Middlesex

The above named Peter Poras personally appeared before me,

on the month, day and year January 20, 2016 and made oath that the above statement is true.

Notary: Sophie Elsa Nitishin

My Commission expires: March 18, 2022

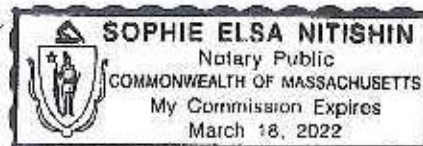

FEE SCHEDULE

Project Address: 18-24 Chauncy Street

Application Date: 1/20/2016

The Applicant must provide the full fee (by check or money order) with the Special Permit Application. Depending on the nature of the proposed project and the types of Special Permit being sought, the required fee is the larger of the following amounts:

- If the proposed project includes the creation of new or substantially rehabilitated floor area, or a change of use subject to Section 19.20, the fee is ten cents (\$0.10) per square foot of total proposed Gross Floor Area.
- If a Flood Plain Special Permit is being sought as part of the Application, the fee is one thousand dollars (\$1,000.00), unless the amount determined above is greater.
- In any case, the minimum fee is one hundred fifty dollars (\$150.00).

Fee Calculation

New or Substantially Rehabilitated Gross Floor Area (SF): 11,152 × \$0.10 = \$1,115

Flood Plain Special Permit Enter \$1,000.00 if applicable:

Other Special Permit Enter \$150.00 if no other fee is applicable:

TOTAL SPECIAL PERMIT FEE Enter Larger of the Above Amounts: 1,115

DIMENSIONAL FORM

Project Address: 18-26 Chauncy Street

Application Date: 1/20/2016

	Existing	Allowed or Required (max/min)	Proposed	Permitted
Lot Area (sq ft)	28,027	5,000	28,027	
Lot Width (ft)	200	80'	200	
Total Gross Floor Area (sq ft)	80,670		80,670	
Residential Base				
Non-Residential Base				
Inclusionary Housing Bonus				
Total Floor Area Ratio	2.87	1.75	2.87	
Residential Base				
Non-Residential Base				
Inclusionary Housing Bonus				
Total Dwelling Units	98	9 per 20,600	107	9
Base Units				
Inclusionary Bonus Units				
Base Lot Area / Unit (sq ft)				
Total Lot Area / Unit (sq ft)				
Building Height(s) (ft)	4 Stories	35'	4 Stories	
Front Yard Setback (ft)	3		3	
Side Yard Setback – Side? (ft)	0		0	
Side Yard Setback – Side? (ft)	0		0	
Rear Yard Setback (ft)	10		10	
Open Space (% of Lot Area)	28.9	30%	28.9	
Private Open Space				
Permeable Open Space				
Other Open Space (Specify)				
Off-Street Parking Spaces				
Bicycle Parking Spaces	21 existing	9 per code	See Below	
Loading Bays				

Use space below and/or attached pages for additional notes:

ice spaces in the building. The Project will result in 16 spaces in a new bicycle shed and 14 spaces in the building, that conform to the design standards of Section 6.49, for a total of 30 bicycle spaces (21 existing and 9 new).



CITY OF CAMBRIDGE, MASSACHUSETTS

PLANNING BOARD

CITY HALL ANNEX, 344 BROADWAY, CAMBRIDGE, MA 02139

CERTIFICATION OF RECEIPT OF PLANS BY CITY OF CAMBRIDGE TRAFFIC, PARKING & TRANSPORTATION

City Department/Office:

Project Address: 18-26 Chauncy Street

Applicant Name: Chauncy Court LLC

For the purpose of fulfilling the requirements of Section 19.20 and/or 6.35.1 and/or 5.28.2 of the Cambridge Zoning Ordinance, this is to certify that this Department is in receipt of the application documents submitted to the Planning Board for approval of a Project Review Special Permit for the above referenced development project: (a) an application narrative, (b) small format application plans at 11" x 17" or the equivalent and (c) Certified Traffic Study. The Department understands that the receipt of these documents does not obligate it to take any action related thereto.

Signature of City Department/Office Representative

Date



CITY OF CAMBRIDGE, MASSACHUSETTS

PLANNING BOARD

CITY HALL ANNEX, 344 BROADWAY, CAMBRIDGE, MA 02139

CERTIFICATION OF RECEIPT OF PLANS BY CITY OF CAMBRIDGE DEPARTMENT OF PUBLIC WORKS

City Department/Office:

Project Address: 18-26 Chauncy Street

Applicant Name: Chauncy Court LLC, c/o Chestnut Hill Realty

For the purpose of fulfilling the requirements of Section 19.20 of the Cambridge Zoning Ordinance, this is to certify that this Department is in receipt of the application documents submitted to the Planning Board for approval of a Project Review Special Permit for the above referenced development project: (a) an application narrative and (b) small format application plans at 11" x 17" or the equivalent. The Department understands that the receipt of these documents does not obligate it to take any action related thereto.

Signature of City Department/Office Representative

Date



CITY OF CAMBRIDGE, MASSACHUSETTS

PLANNING BOARD

CITY HALL ANNEX, 344 BROADWAY, CAMBRIDGE, MA 02139

CERTIFICATION OF RECEIPT OF PLANS BY CITY OF CAMBRIDGE TREE ARBORIST

City Department/Office:

Project Address: 18-26 Chauncy Street

Applicant Name: Chauncy Court LLC, c/o Chestnut Hill Realty

For the purpose of fulfilling the requirements of Section 4.26, 19.20 or 11.10 of the Cambridge Zoning Ordinance, this is to certify that this Department is in receipt of the application documents submitted to the Planning Board for approval of a MultiFamily, Project Review or Townhouse Special Permit for the above referenced development project: a Tree Study which shall include (a) Tree Survey, (b) Tree Protection Plan and if applicable, (c) Mitigation Plan, twenty one days before the Special Permit application to Community Development.

Signature of City Department/Office Representative

Date

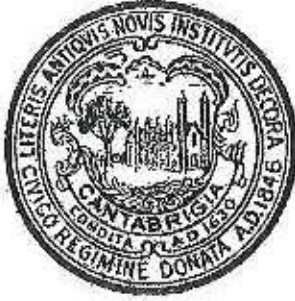

CITY OF CAMBRIDGE, MASSACHUSETTS

PLANNING BOARD

CITY HALL ANNEX, 344 BROADWAY, CAMBRIDGE, MA 02139

CERTIFICATION OF RECEIPT OF PLANS BY CITY OF CAMBRIDGE WATER DEPARTMENT

City Department/Office:

Project Address: 18-26 Chauncy Street

Applicant Name: Chauncy Court LLC, c/o Chestnut Hill Realty

For the purpose of fulfilling the requirements of Section 19.20 of the Cambridge Zoning Ordinance, this is to certify that this Department is in receipt of the application documents submitted to the Planning Board for approval of a Project Review Special Permit for the above referenced development project: (a) an application narrative and (b) small format application plans at 11" x 17" or the equivalent. The Department understands that the receipt of these documents does not obligate it to take any action related thereto.

Signature of City Department/Office Representative

Date



CITY OF CAMBRIDGE, MASSACHUSETTS

PLANNING BOARD

CITY HALL ANNEX, 344 BROADWAY, CAMBRIDGE, MA 02139

CERTIFICATION OF RECEIPT OF PLANS BY CITY OF CAMBRIDGE LEED SPECIALIST

City Department/Office:

Project Address: 18-26 Chauncy Street

Applicant Name: Chauncy Court LLC, c/o Chestnut Hill Realty

For the purpose of fulfilling the requirements of Section 22.20 of the Cambridge Zoning Ordinance, this is to certify that this Department is in receipt of the application documents submitted to the Planning Board for approval of a Special Permit for the above referenced development project: (a) an application narrative, (b) small format application plans at 11" x 17" or the equivalent and (c) completed LEED Project Checklist for the appropriate LEED building standard, accompanying narrative and affidavit. The Department understands that the receipt of these documents does not obligate it to take any action related thereto.

Signature of City Department/Office Representative

Date

**18-26 CHAUNCY STREET, CAMBRIDGE
BASEMENT APARTMENT OVERLAY DISTRICT
PROJECT SUMMARY**

Project Overview

Chestnut Hill Realty's (CHR) property at 18-26 Chauncy Street currently contains 98 apartments. CHR is proposing to add 9 apartments at the basement level pursuant to the Basement Apartment Overlay District, Cambridge Zoning Ordinance 20.600 (the "Project"). The Basement Apartment Overlay District was adopted by the Cambridge City Council in December of 2012 and amended in June 2015. The purpose of the Basement Apartment Overlay District is "to allow for the creation of studio or one-bedroom apartment units in appropriate unused basement level space of certain existing multifamily residential buildings that have one or more existing basement level apartment units." In addition "given the increasing expense of unsubsidized rental housing in Cambridge, the shortage of reasonably priced, affordable studio and one bedroom units, and the difficulty this poses for local workers, students and the elderly, it is in the public interest to permit the creation of additional units under circumstances which promote the maintenance and improvement of older buildings, including improved storm water and wastewater management, and which provide additional housing without building new structures or increasing the size of existing structures."

In addition the Project is required to obtain a Special Permit under Section 6.3.5 for a reduction in the parking requirement.

The Project meets the specific conditions and criteria of the Basement Apartment Overlay District, as amended, as well as the general Special Permit criteria found in Section 10.43 of the Zoning Ordinance.

Compliance with Zoning

18-26 Chauncy Street is in both a C-2 Zone (approximately 20,613 square feet) and a A-1 Zone (approximately 7,414 square feet) and . The following is a zoning chart of the relevant zoning element:

Analysis	C-2	A-1	Existing	Notes
Area	5,000	8,000	28,027	Meets Zoning
Density	1 Unit/600 SF	1 Unit/6,000 SF	98	Existing non-conforming
Floor Area Ration (FAR)	1.75	0.50	2.87	Existing non-conforming
Frontage	NA	80'	200'	Meets Zoning
Front Setback	(H+L)/4, Min. 10'	25'	3'	Existing non-conforming
Side Setback	(H+L)/5	15'	0'	Existing non-conforming
Rear Setback	(H+L)/4, Min. 20'	25'	10'	Existing non-conforming
Usable Open Space (Min)	15%	50%	28.9%	Existing non-conforming
Height	85'	35'	40'	Existing non-conforming
Parking	1 Per Unit	N/A	0	Existing non-conforming

The project is not increasing any of the Existing Non-Conforming elements noted above except for the Density and Allowed Units which the Basement Apartment Overlay District was created to allow with a Special Permit from the Planning Board.

Compliance with Criteria Specific to Special Permits under 20.600

Section 20.600 outlines a number of criteria that the Project must meet to qualify for the Basement Apartment Overlay District:

- a. the structure is located within a Residence C, C-1, C-1A, C-2A, C-2, C-2A, C-2B, C-3, C-3A, or C-3B base zoning district: *18-26 Chauncy Street is almost entirely located in a C-2 district, a small portion is in A-1 Zone which is allowed pursuant to the Basement Apartment Overlay District as Amended;*
- b. the structure is currently occupied by at least thirty (30) dwelling units: *18-26 Chauncy Street currently contains ninety-eight (98) units;*
- c. the structure was built before 1930 and its footprint or foundation has not been expanded or altered after the effective date of this Section 20.600 except as may be required and approved as a condition to the grant of a special permit herunder: *18-26 Chauncy Street was built in 1890;*
- d. the structure currently contains at least one dwelling unit located entirely at the basement level: *18-26 Chauncy Street currently contains six (6) basement dwelling units.*

In addition the Planning Board may waive some or all of the dimensional and parking standards generally applicable in the base district upon issuance of a special permit, subject to the following limitations:

- a. Where the Floor Area Ratio of the existing structure exceeds the maximum Floor Area Ratio allowed in the base zoning district, the Gross Floor Area of the existing structure shall not be increased: *The current Floor Area Ratio at 18-26 Chauncy Street is greater than the allowed Floor Area Ratio in that district, however this project will not increase the Gross Floor Area as the area that is being converted to dwelling units is already included in the Gross Floor Area calculations.*
- b. Where the existing structure or lot does not conform to the height, yard, or private open space requirements generally applicable in the district, the Planning Board may approve those dimensional characteristics of the existing building or lot. However, no nonconforming element or aspect of the existing structure shall be extended or increased, with the exception that the permitted lot area per dwelling unit may be decreased, and incursions into setback areas may be approved by the Planning Board only for the purpose of providing or altering window wells or egress stairs as may be deemed advisable in response to safety and flooding concerns: *18-26 Chauncy Street does not currently conform to the front yard, side yard and rear yard setback requirements, the height requirement and the open space requirement. However these nonconforming elements are preexisting and the Project will not result in any extension or increase in them except for projections into the rear yard setback for window wells and/or patios necessary to provide safe egress from the proposed dwelling units. The lot area per dwelling unit currently does not conform and will be decreased pursuant to 20.600.*
- c. The number of dwelling units in the existing structure shall not be increased by more than ten (10) units or fifteen percent (15%) of the number of dwelling units in the existing building, whichever is fewer: *The Project is adding nine (9) units (9.1%).*
- d. Newly created dwelling units shall be restricted to studio or one-bedroom apartments only: *All nine proposed dwellings are one-bedroom units.*
- e. The Planning Board may reduce or waive the number of accessory off-street motor vehicle parking spaces required by Article 6.000 upon making a finding that such reduction will not result in substantial adverse impacts to on-street parking, based on information provided by the Applicant regarding the availability of alternate transportation options or other factors that would result in a reduced demand for parking. As a condition of a special permit, the Planning Board may require measures to minimize parking demand generated by the building. The requirements of Article 6.000 may not otherwise be waived: *Adding nine dwelling units will have a de minimis effect on parking. The Basement Apartment Overlay District was created in areas with close proximity to public transportation to encourage the use of using public transportation. In addition CHR has a Transportation Advisor on staff who advises our leasing professionals and residents on such things as public transportation providing maps and information and walking directions*

to nearby amenities. Furthermore CHR has rental car services nearby that residents can take use when a car is necessary. Finally there are four existing parking lots owned by CHR within a 2 block radius containing a total of 96 spaces available to the residents of CHR's Cambridge Properties. If a renter of one of the proposed new basements units has a car CHR will rent them an off-street parking space nearby. CHR recently completed and leased four basement units at 19-21 Wendell Street approved under this Bylaw and none of these new tenants had a vehicle. Similarly, this Project is projected to produce a negligible increase in off-street parking demand.

- f. At least one additional secure long-term bicycle storage space shall be created on the lot for each new dwelling unit created under the provisions of this Section: *There are 21 existing bicycle spaces. The Project will result in 16 spaces in a new bicycle shed and 14 spaces in the building, that conform to the design standards of Section 6.49, for a total of 30 bicycle spaces (21 existing and 9 new). Therefore the Project will result in the creation of nine new bicycle storage spaces that conform to the design standards of Section 6.49.*

Prior to granting a special permit pursuant to Section 20.600 the Planning Board shall determine that the proposed conversion of basement space to dwelling units complies with the General Special Permit Criteria set forth in Section 10.43 as well as with the following requirements:

- a. Each new unit converted from existing basement space shall comply with all building, health, and accessibility codes applicable to residential dwelling units in the basement of structures: *The Project will meet all building and sanitary code requirements applicable to basement units.*
- b. Buildings must contain, or install, full separation between storm water and sanitary sewer lines from the building to the connection in the street regardless of whether the street in which the building is connected currently is separated: *18-26 Chauncy Street currently has a full separation between storm water and sanitary sewer lines inside the building and will be updating the current lines to conform to code and pursuant to the approved engineering report and will be separating the lines from the building to the street pursuant to the approved engineering report (see d. below).*
- c. Adequate, properly installed, backflow prevention devices that comply with all building code and other applicable requirements must be installed for all newly created units along with any additional measures determined to be advisable by the City Engineer: *The nine proposed dwelling units will have backflow preventers on all plumbing fixtures.*
- d. An application for a special permit pursuant to this Section shall include a report on historical occurrences and future likelihood of basement flooding in the area of the proposed conversion, prepared by a registered professional engineer, with a functional scope determined by the City Engineer to be appropriate to the location of the project: *A Report was submitted to the City Engineer on October 26, 2015 and was revised on December 8, 2015. The Report was approved by the City Engineer on January 14, 2016. The report concluded there was a minimal likelihood of flooding in the basement units by way of sewer system backups or overland flooding. In addition, the Report identified proposed mitigation measures to prevent any such flooding including ensuring all sanitary and drainage lines both inside the building and from the building to the street are sized properly, including replacing the two 4" sanitary lines with two 6" lines and the 2" storm drainage lines with one 6" line and one 8" line, and adding leaching pits for any proposed egress areas and window wells. In addition revisions were made to address all existing and proposed grading situations to prevent any flooding at low points and the Climate Change Vulnerability Assessment report was reviewed with John Bolduc of the Cambridge Community Development Department.*
- e. The Inclusionary Housing requirements of Section 11.200 shall apply to any new dwelling units that exceed the threshold for an Inclusionary Project as set forth in Section 11.201. Any project which receives a special permit pursuant to this Section, but does not exceed the threshold for an Inclusionary Project, shall provide no less than one Affordable Unit, as defined in section 11.201 and subject to the Standards for Construction and Occupancy of Affordable Units set forth in Section 11.204: *One (1) of the nine (9) proposed dwelling units will an Affordable Unit.*

Compliance with General Special Permit Criteria under 10.300

Special permits will normally be granted where specific provisions of this Ordinance are not, except when particulars of the location or use, not generally true of the district or of the uses permitted in it, would cause granting of such permit to be to the detriment of the public interest because:

- a. It appears that requirements of this Ordinance cannot or will not be met: *The Project meets the requirements of 20.600, the Basement Apartment Overlay District, and will not result in any extension or increase to preexisting nonconforming elements except those allowed pursuant to 20.6000;*
- b. traffic generated or patterns of access or egress would cause congestion, hazard, or substantial change in established neighborhood character: *the addition of nine dwelling units in a densely populated residential district is a negligible increase in population, results in a de minimis increase in traffic, the off-street parking demand for few or no cars, and keeps with the residential character of the neighborhood;*
- c. the continued operation of or the development of adjacent uses as permitted in the Zoning Ordinance would be adversely affected by the nature of the proposed use: *the Project will have no adverse effect on any other adjacent uses because it is a residential use in a residential district;*
- d. nuisance or hazard would be created to the detriment of the health, safety and/or welfare of the occupant of the proposed use or the citizens of the City: *the Project is designed to meet all building and health codes and to provide a similar quality of life to its occupants as any other dwelling units and in addition will present no nuisance or hazard to the citizens of the City;*
- e. for other reasons, the proposed use would impair the integrity of the district or adjoining district, or otherwise derogate from the intent and purpose of this Ordinance: *the residential use in a residential district does not impair the integrity of the district and is promotes the intent and purpose of the Zoning Ordinance by making appropriate use of wasted underutilized basement space, which is in line with purpose "to encourage the most rational use of land throughout the City", provides needed moderately priced housing which is in line with purpose "to encourage housing for persons of all income levels" and encourages the use of mass transit while mitigating the need for on-street parking which is in line with the purpose to "lessen congestion in the street."*

Summary

In summary, the proposal to add nine dwelling units at 18-26 Chauncy Street pursuant to the Basement Apartment Overlay District meets the specific criteria and conditions for granting a Special Permit found in Section 20.600, meets the general special permit criteria of Zoning Ordinance, is not detrimental to the public interest, and does not derogate from the intent and purpose of the Cambridge Zoning Ordinance. For all the reasons stated herein the Planning Board should grant the Special Permit to add nine dwelling units at 18-26 Chauncy Street.

**CHESTNUT HILL REALTY
18-26 CHAUNCY STREET
BASEMENT APARTMENT OVERLAY DISTRICT**

**PARKING AND TRANSPORTATION STUDY
December 2015**

CHR has filed a Special Permit Application with the Cambridge Planning Board for 9 basement apartments under the City of Cambridge Basement Apartment Overlay District, Section 20.600.

Pursuant to 20.600, CLR is asking for a waiver of the off-street parking requirement of Article 6.000. Such a reduction will not result in adverse impacts to on-street parking based on the following:

1. Transportation Survey

In 2013, Chestnut Hill Realty surveyed its residents of 19-21 Wendell Street, 18-26 Chauncy Street, 1-3 Langdon Street and 60 Brattle Street (see attached Parking/Transportation Survey Results). The results of the survey showed that less than half of CHR's residents own their own car and of those who do, many do not use them as their primary means of transportation. Primary use of transportation other than cars was reported by nearly 2 out of 3 tenants.

Separately, in 2013, 2014 and 2015, CHR surveyed the residents of the existing 13 basement apartments at the above four properties (see attached Parking/Transportation Survey Results). In 2013, none of the basement apartment residents owned a car. In 2014, we had 2 basement renters who owned a car and both rented spaces at one of our existing off-street parking facilities. In 2015, we had 2 basement renters own a car and 2 rented spaces at our existing off-street parking facilities (see No. 3 below).

Most relevant, CLR recently completed and leased 4 basement apartment units at 19-21 Wendell Street that were created under this Bylaw. None of these renters have a car.

Based on the above information, it is reasonable to assume that the 9 proposed units at 18-26 Chauncy Street will create negligible on-street parking demand. If there are any new basement residents that have a car, they can rent one of CHR's existing off-street parking nearby spaces.

2. Public Transportation

The Basement Apartment Overlay District was created in areas on close proximity to public transportation to further mitigate the need for owning a car. There are two MBTA Bus Stops within 2 blocks, and two T-Stops located within ½ mile of 18-26 Chauncy Street.

3. CHR Parking Areas

There are four existing parking lots owned by CHR within a 2 block radius of Chauncy Street containing a total of 96 spaces. 1-3 Langdon Street has 22 spaces, 15-17 Langdon St. has 14 spaces, 65 Langdon St. has 23 Spaces, 1-3 Langdon Square has 8 spaces and 1-3 Chauncy St. has 29 spaces. These spaces are available to the residents of CHR's Cambridge properties. Currently, there is a minimal waiting list for these spaces, with about 2-3 spaces turning over every month. If a renter of one of the proposed new basements units has a car, we will rent them an off-street parking space.

4. Zip Car

There are 2 Zip Car's in CHR's off-street parking lot at 1-3 Langdon Street and residents of the new units can easily schedule the use of these Zip Cars. This service further mitigates the need for owning a car.

5. Transportation Advisor

The Chestnut Hill Realty created the position of Cambridge Transportation Advisor to educate all of CHR's Resident Services Professionals (RSP's) about the different transportation options available to residents. The Transportation Advisor works closely with the City of Cambridge and the MBTA to gather information about public transportation and alternate methods of transportation other than the use of a car. This information includes the location of T stops, the location and times of nearby bus routes, the location and use of bicycle racks and bicycle paths and walking directions to nearby stores and attractions. The Transportation Advisor recommends to the RSP's the best options the residents have to get to where they need to go. The RSP's convey this information to all of CHR's prospective residents during the leasing process. The Transportation Advisor also assists the RSP's in purchasing Charlie Cards for the residents.

6. Bicycles

Per the Basement Apartment Overlay District Bylaw, CHR will install 9 new bicycle spaces that meet current Zoning regulations. These 9 spaces conveniently located in the basement will be built inside the building and will conform to the Cambridge Bicycle Bylaw.

Currently, CHR has 21 existing bicycle spaces. CHR will build an exterior bicycle storage shed that will contain 16 bike racks (3 more than currently provided). The bicycle storage shed is fully enclosed, secure and covered. In additional 5 spaces will be installed inside the conform to the Cambridge Bicycle Bylaw.

7. Off- Street Parking Study

At the suggestion of the City of Cambridge Traffic, Parking and Transportation Department (TPT), CHR conducted an on-street parking study for the area within 1/2 mile of 18-26 Chauncy Street. The study was conducted on July 23, 2015 at approximately 10:30-11:30 pm. The study area contained 152 total on street parking spaces. At the time of the study 22 spaces were available. A map of the area and location of the available spaces is attached. Based on the study results, there appears to be more than enough on-street capacity to accommodate the negligible parking demand that may arise from these nine proposed units.

**18-26 Chauncy Street, Cambridge
Basement Apartment Overlay District
Community Engagement Process Summary**

On Wednesday September 30, 2015, we held a community meeting in the courtyard of 18-26 Chauncy Street at 6:30 PM. We invited our abutters by letter as well as the neighborhood groups from Agassiz Baldwin and Neighborhood Nine who we contacted through their neighborhood liaison. We send all of them information about the proposed basement apartments and the purpose of the zoning bylaw that allows basement apartments.

Although, no one attended the community meeting, two people contacted us for more information which we provided.

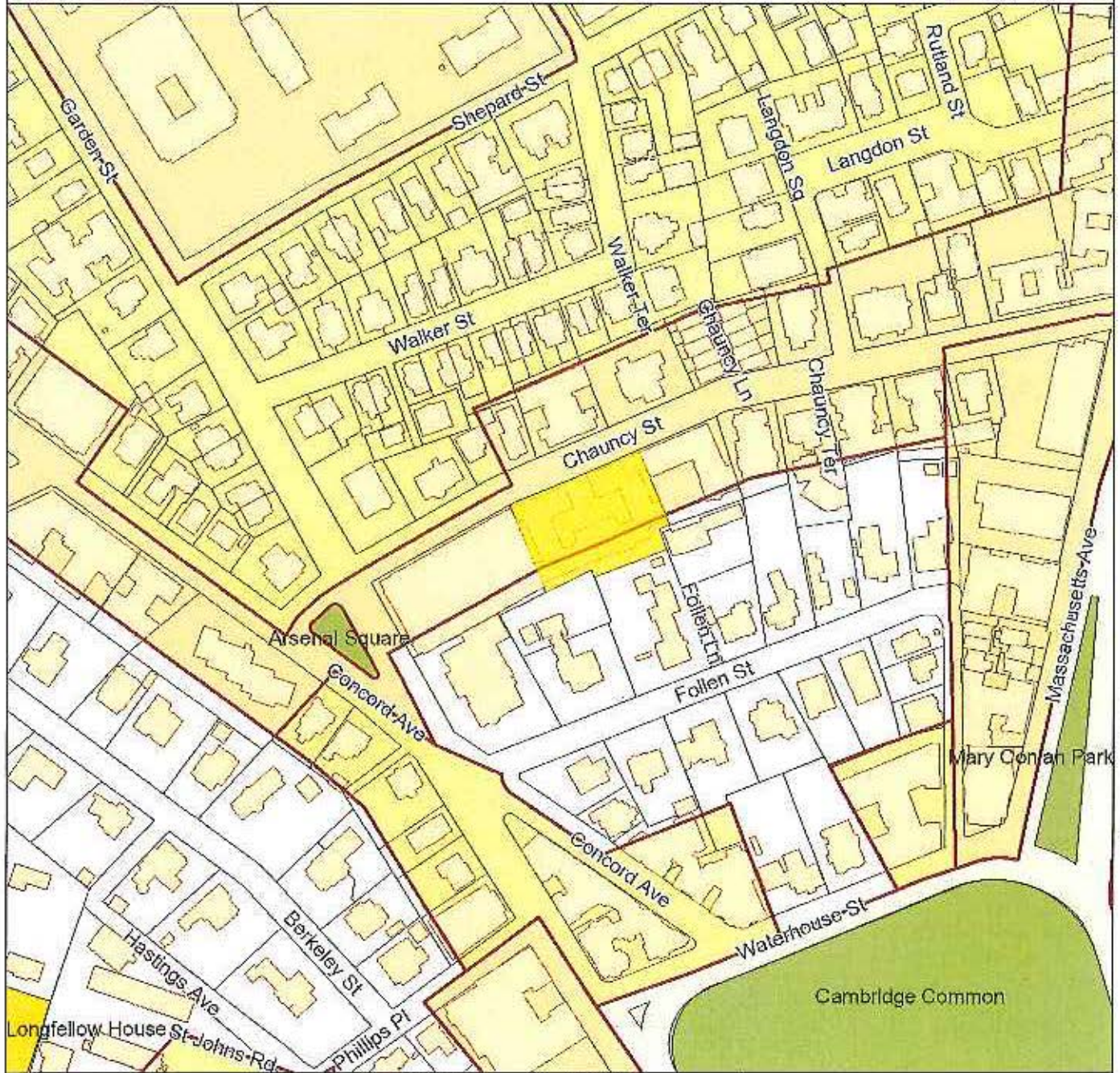

City of Cambridge
Massachusetts

1" = 210 ft

All data is provided for graphic representation only. The City of Cambridge expressly disclaims all warranties of any type, expressed or implied, including, but not limited to, any warranty as to the accuracy of the data, merchantability, or fitness for a particular purpose.

www.cambridgema.gov/gis

- Zoning Bo
- City Boundary
- Buildings
- Open Water
- River
- Pond
- Wetland
- Stream

- Zoning Districts**
- Residence A-1
- Residence A-2
- Residence B
- Residence C
- Residence C-1
- Residence C-1A
- Residence C-2
- Residence C-2A
- Residence C-2B
- Residence C-3
- Residence C-3A
- Residence C-3B
- Office-1
- Office-2
- Office-2A
- Office-3
- Office-3A
- Business A
- Business A-1
- Business A-2
- Business A-3
- Business B
- Business-1
- Business 2
- Business C
- Industry A-1
- Industry A-2
- Industry A
- Industry B-1
- Industry B-2

ARLINGTON MEDFORD



BOSTON

Chauncy Neighborhood



Chauncy Front of Building



Chauncy Back of Building



Chauncy Existing Conditions

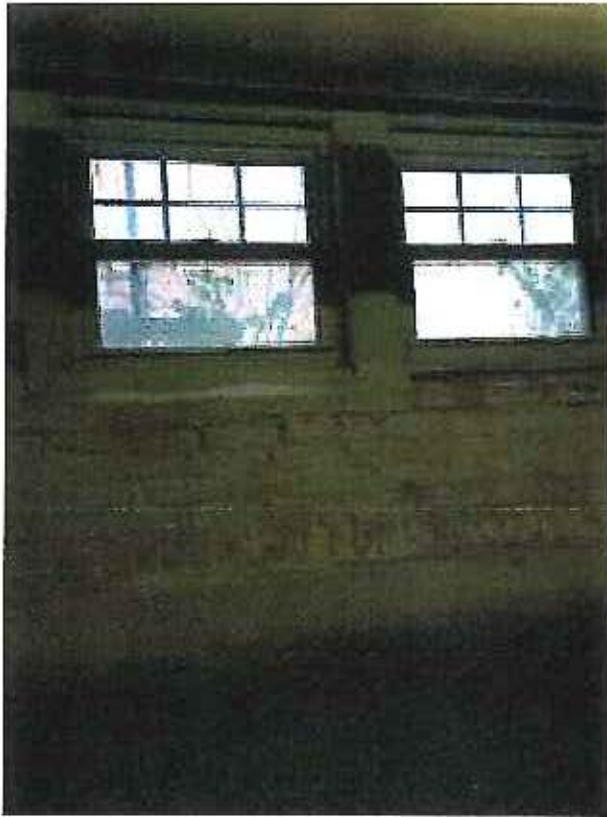

THESE PLANS AND SPECIFICATIONS ARE PROTECTED UNDER FEDERAL COPYRIGHT LAWS. © LOWE ASSOCIATES - ARCHITECTS, INC. MAINTAINS OWNERSHIP OF SUCH AND ALL RIGHTS AND PRIVILEGES. THESE PLANS AND SPECIFICATIONS ARE NOT TO BE DUPLICATED, REPRODUCED OR USED IN ANY PART OR IN WHOLE FOR ANY OTHER PURPOSE, PROJECT, OWNER OR LOCATION WITHOUT PRIOR WRITTEN CONSENT OF THE ARCHITECT.

PROJECT NUMBER	REVISION NO.	DATE
FILE NAME		
SCALE	1/8"=1'-0"	
DATE	7/31/2015	
DRAWN BY		

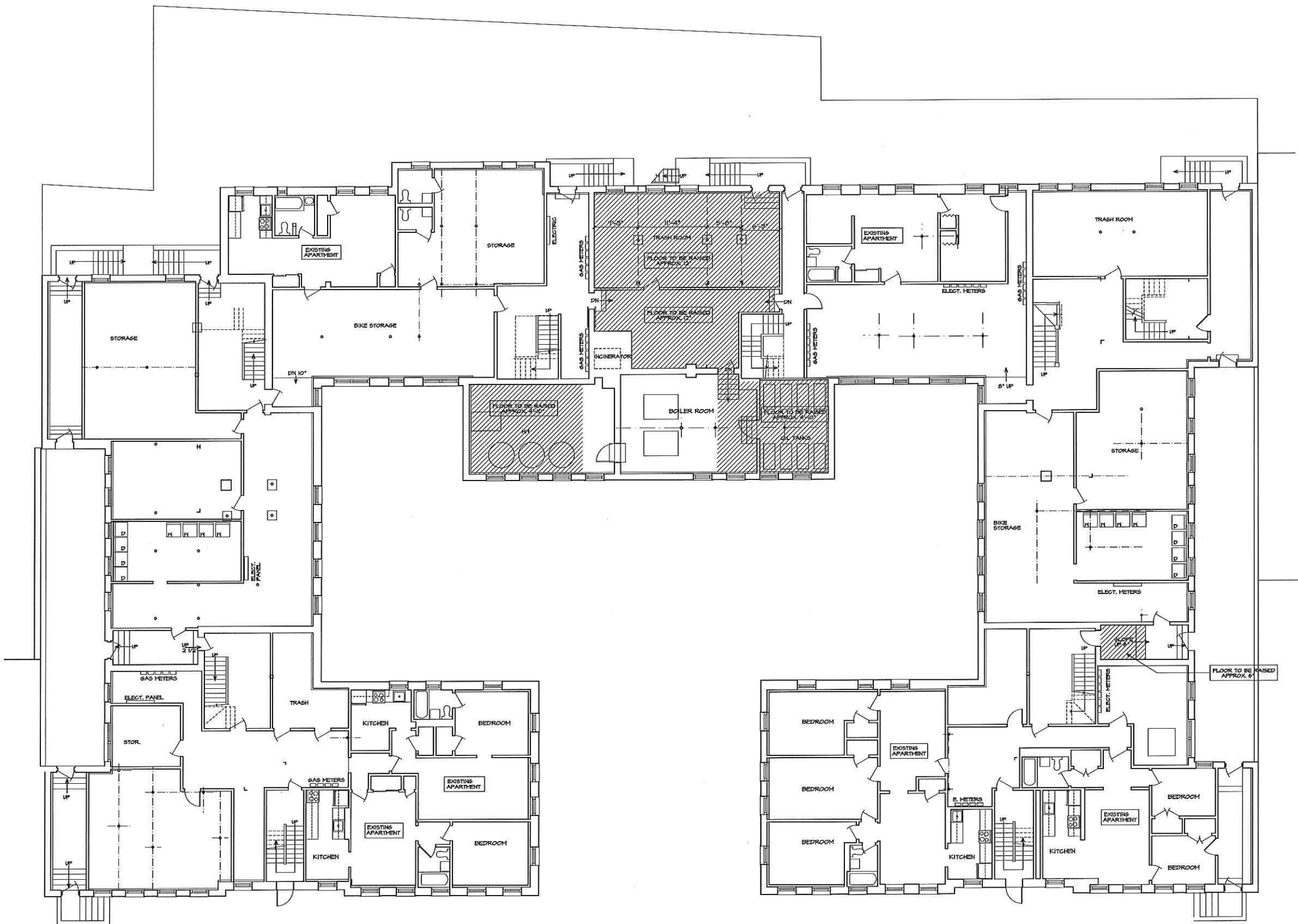

LOWE ASSOCIATES
Architects, Inc.

643 VFW Parkway
Suite 200
Chestnut Hill
Massachusetts 02467
Tel: (617) 323-0078
Fax: (617) 323-8670

CHAUNCY COURT

18-26 CHAUNCY ST.
CAMBRIDGE
MASSACHUSETTS

EXISTING CONDITIONS PLAN

EXISTING CONDITIONS PLAN

PROGRESS 7/31/15

THESE PLANS AND SPECIFICATIONS ARE PROTECTED UNDER FEDERAL COPYRIGHT LAWS. © LOWE ASSOCIATES - ARCHITECTS, INC. MAINTAINS OWNERSHIP OF SUCH AND ALL RIGHTS AND PRIVILEGES. THESE PLANS AND SPECIFICATIONS ARE NOT TO BE DUPLICATED, REPRODUCED OR USED IN ANY PART OR IN WHOLE FOR ANY OTHER PURPOSE, PROJECT, OWNER OR LOCATION WITHOUT PRIOR WRITTEN CONSENT OF THE ARCHITECT.

PROJECT NUMBER	REVISION NO.	DATE
FILE NAME		
SCALE 1/8" = 1'-0"		
DATE 2/12/2016		
DRAWN BY		

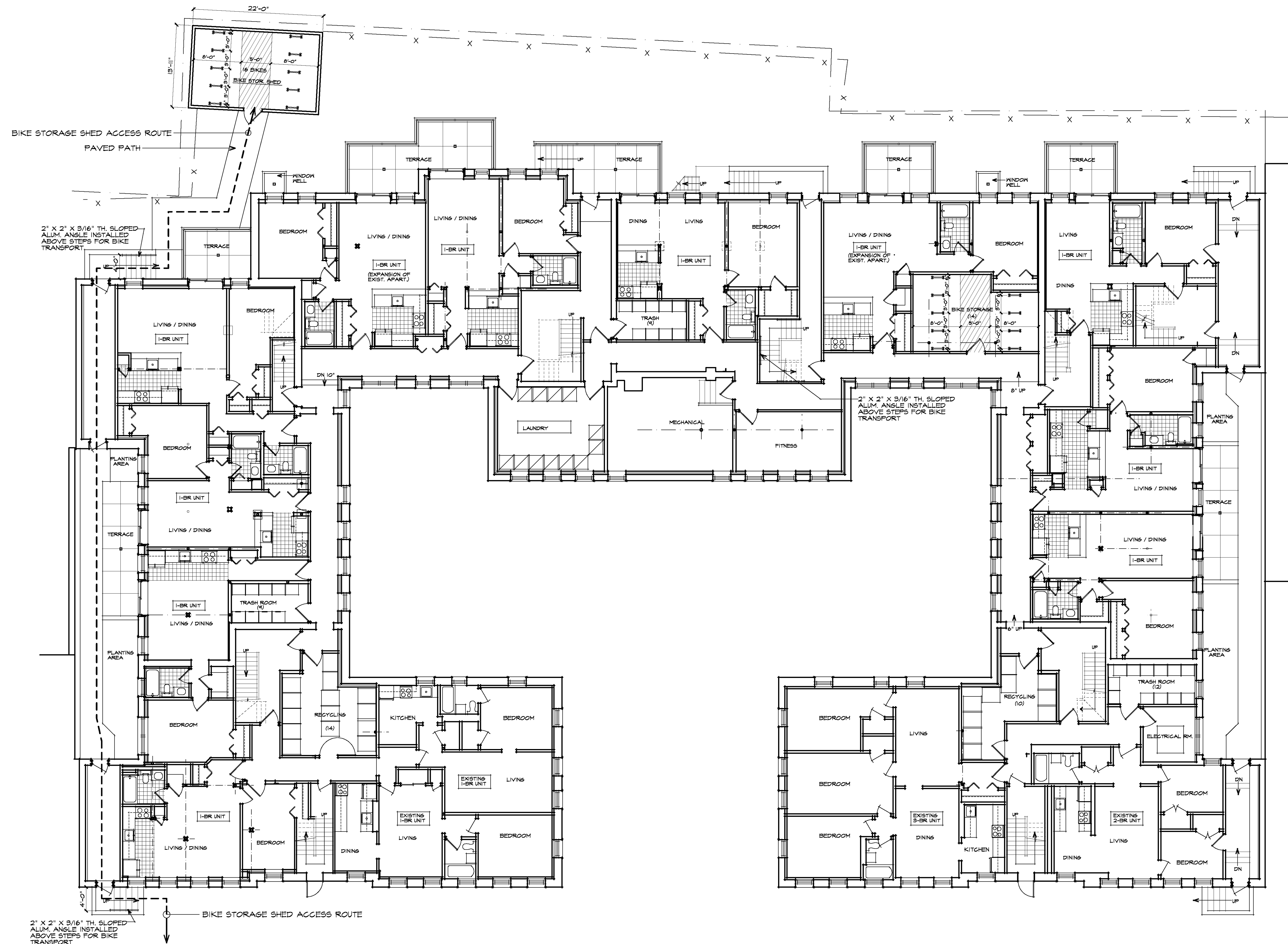

PROPOSED BASEMENT PLAN

LOWE ASSOCIATES
Architects, Inc.

643 VFW Parkway
Suite 200
Chestnut Hill
Massachusetts 02467

Tel: (617) 323-0078
Fax: (617) 323-8670

CHAUNCY COURT

18-26 CHAUNCY ST.
CAMBRIDGE
MASSACHUSETTS

PROPOSED BASEMENT PLAN

A-1

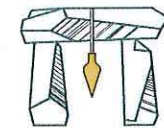

GENERAL NOTES:

- LOCUS: ASSESSORS MAP 172 LOT 61
 RECORD OWNER: CHAUNCY COURT LLC
 DEED REFERENCE: BOOK 35600 PAGE 150
 PLAN REFERENCE: M172 L61
- THIS PLAN IS THE RESULT OF AN ON THE GROUND SURVEY PERFORMED BY THIS OFFICE IN JUNE 2015. ELEVATIONS SHOWN ON CITY OF CAMBRIDGE DATUM, PROPERTY LINE AND BUILDING LOCATION FROM AN ALTA/ACSM LAND TITLE SURVEY PLAN PREPARED BY OTTE & DWYER, INC. FOR 18-26 CHAUNCY STREET CAMBRIDGE, MA DATED 4-15-02.
- EXISTING UTILITIES WHERE SHOWN IN THE DRAWINGS ARE FROM SURFACE OBSERVATION AND RECORD INFORMATION AND SHOULD BE CONSIDERED APPROXIMATE. THE CONTRACTOR SHALL BE RESPONSIBLE FOR PROPERLY LOCATING AND COORDINATING THE PROPOSED CONSTRUCTION ACTIVITY WITH DIG-SAFE AND THE APPLICABLE UTILITY COMPANIES AND MAINTAINING THE EXISTING UTILITY SYSTEM IN SERVICE.
 DIG-SAFE SHALL BE NOTIFIED PER THE STATE OF MASSACHUSETTS STATUTE CHAPTER 82, SECTION 409 AT TEL. 1-888-344-7233. THE ENGINEER DOES NOT GUARANTEE THE ACCURACY OR THAT ALL UTILITIES AND SUBSURFACE STRUCTURES ARE SHOWN. LOCATIONS AND ELEVATIONS OF UNDERGROUND UTILITIES WERE TAKEN FROM RECORD PLANS. THE CONTRACTOR SHALL VERIFY SIZE, LOCATION, AND INVERTS OF UTILITIES AND STRUCTURES AS REQUIRED PRIOR TO THE START OF CONSTRUCTION.
- THE LOT SHOWN DOES NOT LIE WITHIN A SPECIAL FLOOD HAZARD ZONE.

PROJECT TITLE & LOCATION:

PROPOSED BASEMENT APARTMENTS
 18-26 CHAUNCY STREET
 CAMBRIDGE, MA

PLAN TITLE:

SITE PLAN
 PREPARED FOR:
CHESTNUT HILL REALTY
 300 INDEPENDENCE DRIVE
 BROOKLINE, MA 02467

DATE: DECEMBER 2, 2015
 REVISED:

JOB NUMBER: 15.012 SHEET 1 OF 2
 SCALE: 1"=20'

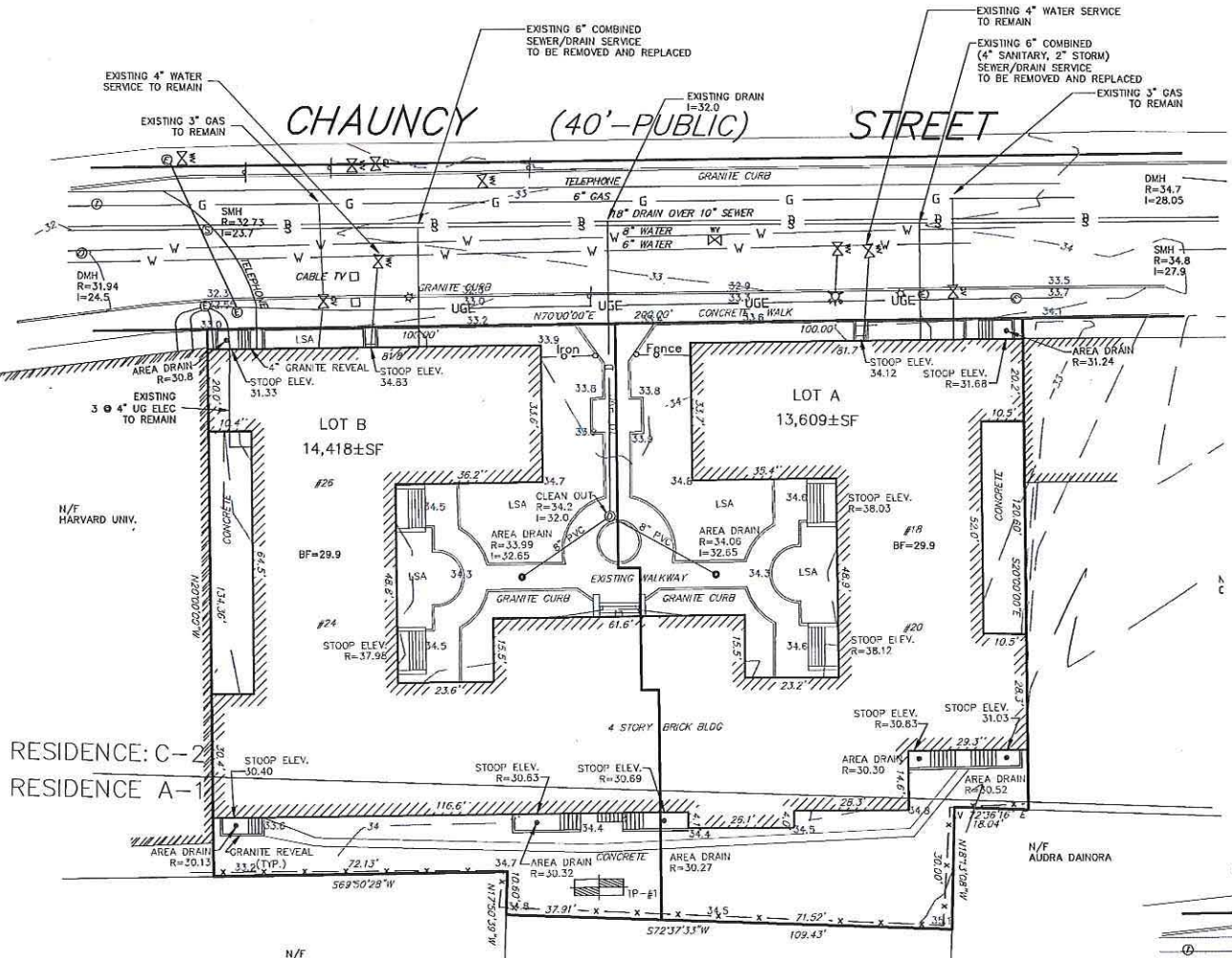

EXISTING CONDITIONS

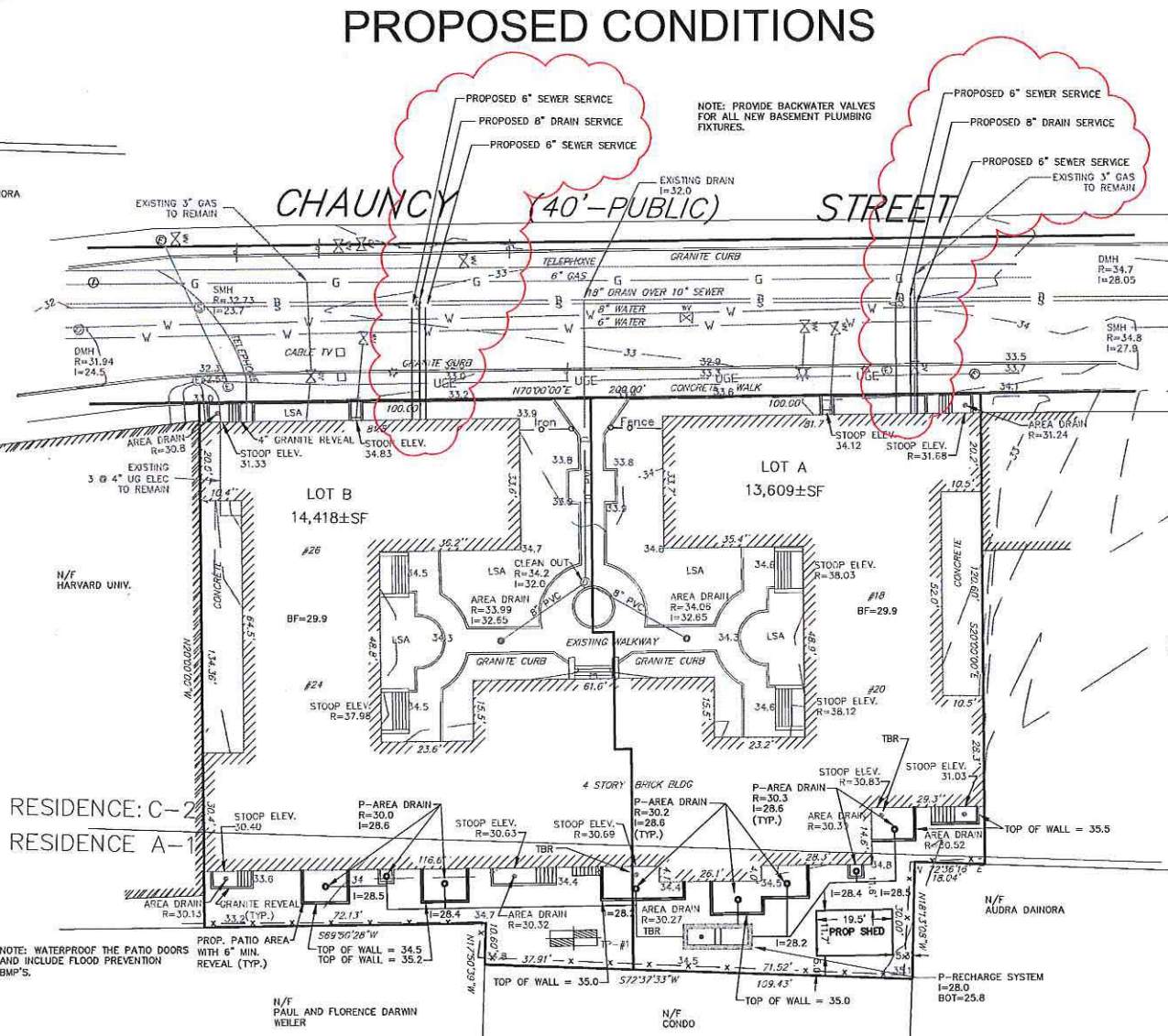

PROPOSED CONDITIONS

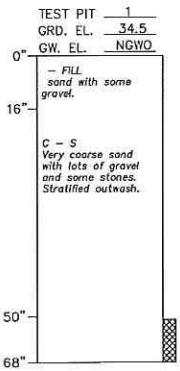

DATE: 10/21/15
 TEST BY: SOIL EVALUATOR J. BURKE P.E.
 PERC. RATE: <2 MIN./INCH
 SOIL CLASS: 1

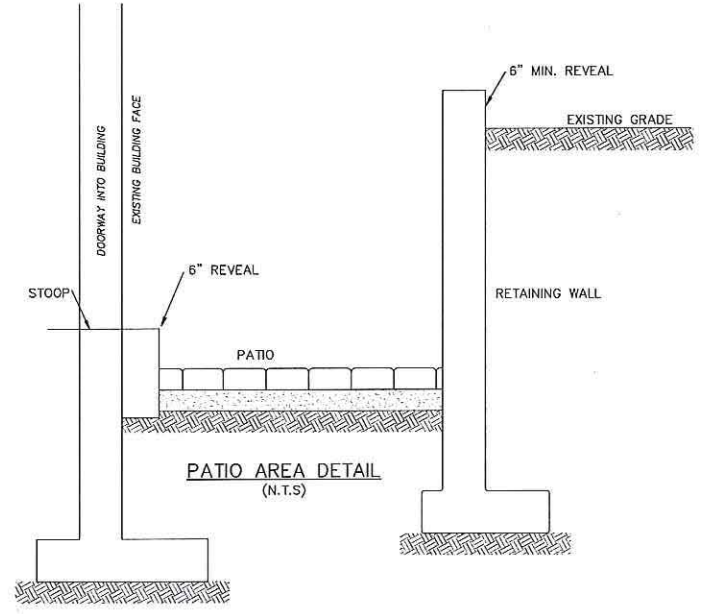

PATIO AREA DETAIL (N.T.S.)

NOTE: WATERPROOF THE PATIO DOORS AND INCLUDE FLOOD PREVENTION BMP'S.

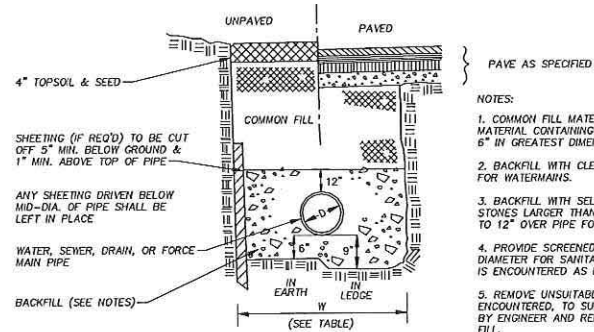
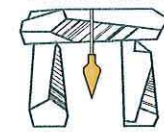

- NOTES:**
- COMMON FILL MATERIAL TO CONSIST OF GRANULAR MATERIAL CONTAINING NO STONES LARGER THAN 6" IN GREATEST DIMENSION.
 - BACKFILL WITH CLEAN SAND TO 12" OVER PIPE FOR WATERMANS.
 - BACKFILL WITH SELECT MATERIAL CONTAINING NO STONES LARGER THAN 3" IN GREATEST DIMENSION TO 12" OVER PIPE FOR SEWER AND DRAIN PIPES.
 - PROVIDE SCREENED GRAVEL BEDDING TO MID PIPE DIAMETER FOR SANITARY SEWERS AND WHERE GROUNDWATER IS ENCOUNTERED AS DIRECTED BY THE ENGINEER.
 - REMOVE UNSUITABLE MATERIAL BELOW GRADE IF ENCOUNTERED, TO SUITABLE DEPTHS AS DIRECTED BY ENGINEER AND REPLACE WITH CLEAN GRANULAR FILL.

TRENCH WIDTH		
D DIAMETER OF PIPE	W UNSHEETED	W SHEETED
TO 12"	3'	4'
14" TO 24"	4'	5'
30" TO 36"	5'	6'

- NOTES:**
- ALL TRENCH CONSTRUCTION TO CONFORM TO APPLICABLE FEDERAL, STATE AND LOCAL REGULATIONS.
 - COMPACT FILL AND TAMP PIPE TO 93% MAX. DENSITY UNLESS OTHERWISE SPECIFIED.

TYPICAL TRENCH SECTIONS
NOT TO SCALE

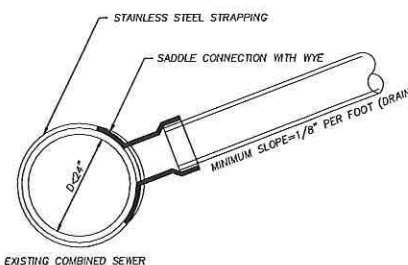

- NOTES:**
- FULL PVC OR IRON SADDLE MAY BE USED TO CONNECT TO EXISTING PVC, CLAY CONCRETE OR IRON PIPE.
 - SADDLES MUST HAVE RUBBER GASKETS AND SHALL BE TIGHTENED WITH STRAPS. SADDLES WILL NOT BE CEMENTED ONTO THE PIPE.
 - FULL WYE CONNECTION FITTINGS MAY BE USED.
 - PIPE SHALL BE CUT TO CONFORM TO THE OPENING IN THE SADDLE.
 - CONNECTIONS DIRECTLY INTO EXISTING PIPE WITHOUT A SADDLE OR A FULL WYE FITTING ARE NOT ALLOWED.

TYPICAL SADDLE CONNECTION TO EXISTING COMBINED SEWER

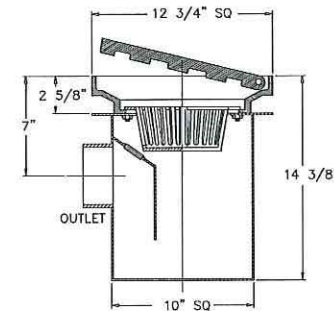

TYPICAL AREA DRAIN
N.T.S.

GENERAL NOTES:

- LOCUS: ASSESSORS MAP 172 LOT 61
 RECORD OWNER: CHAUNCY COURT LLC
 DEED REFERENCE: BOOK 35600 PAGE 150
 PLAN REFERENCE: M172 L61
- THIS PLAN IS THE RESULT OF AN ON THE GROUND SURVEY PERFORMED BY THIS OFFICE IN JUNE 2015. ELEVATIONS SHOWN ON CITY OF CAMBRIDGE DATUM. PROPERTY LINE AND BUILDING LOCATION FROM AN ALTA/ACSM LAND TITLE SURVEY PLAN PREPARED BY OTTE & DWYER, INC. FOR 18-26 CHAUNCY STREET CAMBRIDGE, MA DATED 4-15-02.
- EXISTING UTILITIES WHERE SHOWN IN THE DRAWINGS ARE FROM SURFACE OBSERVATION AND RECORD INFORMATION AND SHOULD BE CONSIDERED APPROXIMATE. THE CONTRACTOR SHALL BE RESPONSIBLE FOR PROPERLY LOCATING AND COORDINATING THE PROPOSED CONSTRUCTION ACTIVITY WITH DIG-SAFE AND THE APPLICABLE UTILITY COMPANIES AND MAINTAINING THE EXISTING UTILITY SYSTEM IN SERVICE.
 DIG-SAFE SHALL BE NOTIFIED PER THE STATE OF MASSACHUSETTS STATUTE CHAPTER 82, SECTION 409 AT TEL. 1-800-344-7233. THE ENGINEER DOES NOT GUARANTEE THEIR ACCURACY OR THAT ALL UTILITIES AND SUBSURFACE STRUCTURES ARE SHOWN. LOCATIONS AND ELEVATIONS OF UNDERGROUND UTILITIES WERE TAKEN FROM RECORD PLANS. THE CONTRACTOR SHALL VERIFY SIZE, LOCATION, AND INVERTS OF UTILITIES AND STRUCTURES AS REQUIRED PRIOR TO THE START OF CONSTRUCTION.
- THE LOT SHOWN DOES NOT LIE WITHIN A SPECIAL FLOOD HAZARD ZONE.

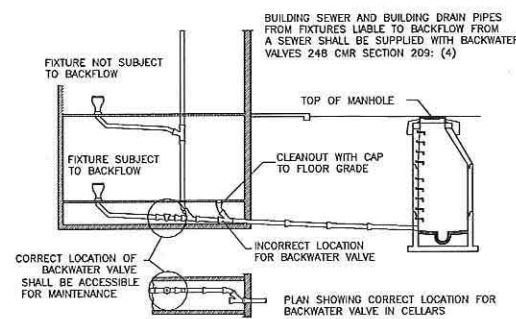

NOTE: ALL PLUMBING FIXTURES BELOW THE LEVEL OF THE TOP OF THE MANHOLE OF THE SEWER SERVING THE FIXTURE(S) SHALL BE CONSIDERED AS BEING SUBJECT TO BACKFLOW AND SHALL BE SUPPLIED WITH BACKWATER VALVES.

BACKWATER VALVE LOCATION
N.T.S.

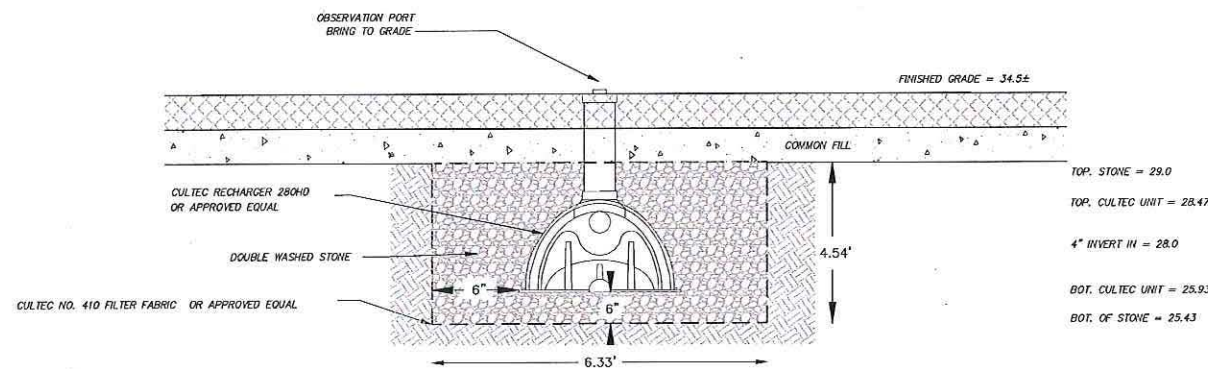

- TOP. STONE = 29.0
- TOP. CULTEC UNIT = 28.47
- 4" INVERT IN = 28.0
- BOT. CULTEC UNIT = 25.93
- BOT. OF STONE = 25.43

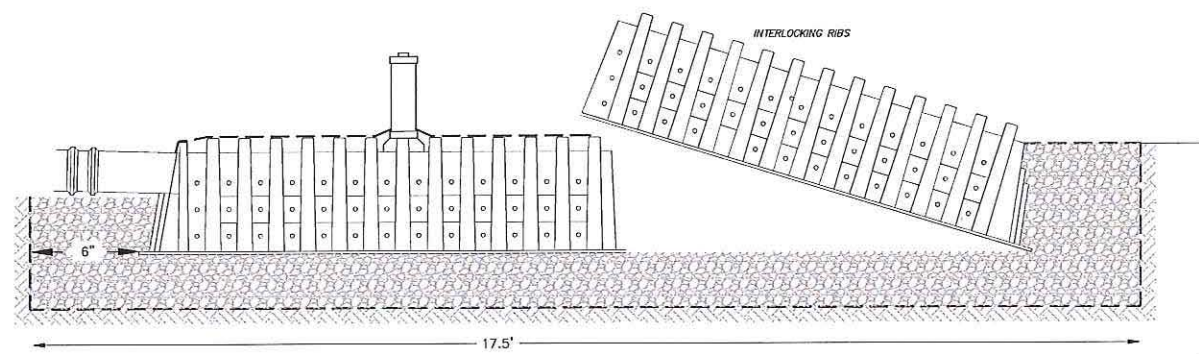

CULTEC CHAMBER TYPICAL PROFILE
NOT TO SCALE

OVER-EXCAVATION NOTES:

THE CONTRACTOR SHALL REMOVE ALL TOPSOIL, SUBSOIL AND OTHER DELETERIOUS MATERIAL WITHIN 24" OF THE LIMIT OF THE STONE SURROUNDING THE CULTEC UNIT AS INDICATED ON THE PLANS.
 THE REMOVED SOIL SHALL BE DISPOSED OF IN A LEGAL MANNER.
 THE REMOVED SOIL SHALL BE REPLACED WITH CLEAN GRANULAR SAND CONFORMING TO THE FOLLOWING SIEVE ANALYSIS:

% PASSING	SIEVE SIZE
100	#4
10-100	#50
0-20	#100
0-5	#200

OBSERVATION PORT INSTALLATION NOTES:

CONTRACTOR TO CUT 6" HOLE AT TOP OF CHAMBER IN THE CENTER OF THE UNIT.
 INSERT A 6" INTERNAL COUPLING INTO INSPECTION PORT OPENING.
 USE A 6" SCH.40 PVC PIPE TO BRING INSPECTION PORT TO WITHIN 6" OF FINISHED GRADE.
 INSTALL A 6" SCH.40 END CAP OR PLUG.
 BACKFILL IN ACCORDANCE WITH SPECIFICATIONS.

CULTEC CHAMBER INSTALLATION NOTES:

CONTRACTOR TO INSTALL CULTEC CHAMBERS IN ACCORDANCE WITH MANUFACTURERS SPECIFICATIONS.
 CULTEC NO. 410 FILTER FABRIC OR APPROVED EQUAL TO BE PLACED OVER THE TOP OF THE DRAINAGE SYSTEM PRIOR TO BACKFILL.
 CONTRACTOR TO REMOVE ALL LOAM, SUBSOIL AND ALL DELETERIOUS MATERIAL FROM EXCAVATION PRIOR TO PLACEMENT OF THE STONE BED.

PROJECT TITLE & LOCATION:

PROPOSED BASEMENT APARTMENTS
 18-26 CHAUNCY STREET
 CAMBRIDGE, MA

PLAN TITLE:

CONSTRUCTION DETAILS

PREPARED FOR:

CHESTNUT HILL REALTY
 300 INDEPENDENCE DRIVE
 BROOKLINE, MA 02467

DATE: DECEMBER 2, 2015

REVISED:

JOB NUMBER: 15.012 SHEET 2 OF 2

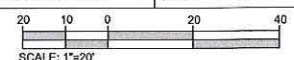

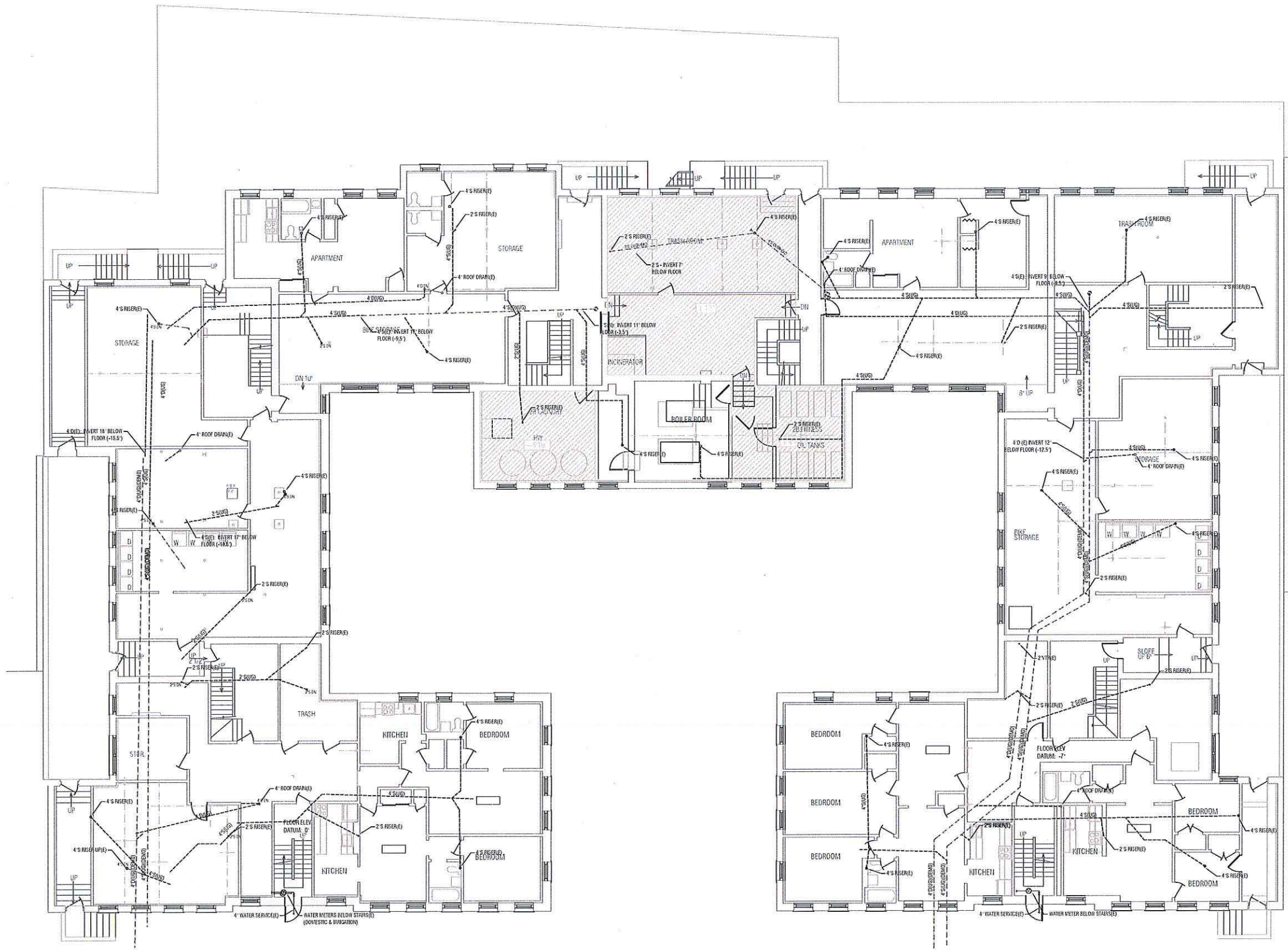

SANITARY & STORM DRAINAGE - DEMO

NOTE: PROVIDE BACKWATER VALVES FOR ALL NEW BASEMENT PLUMBING FIXTURES

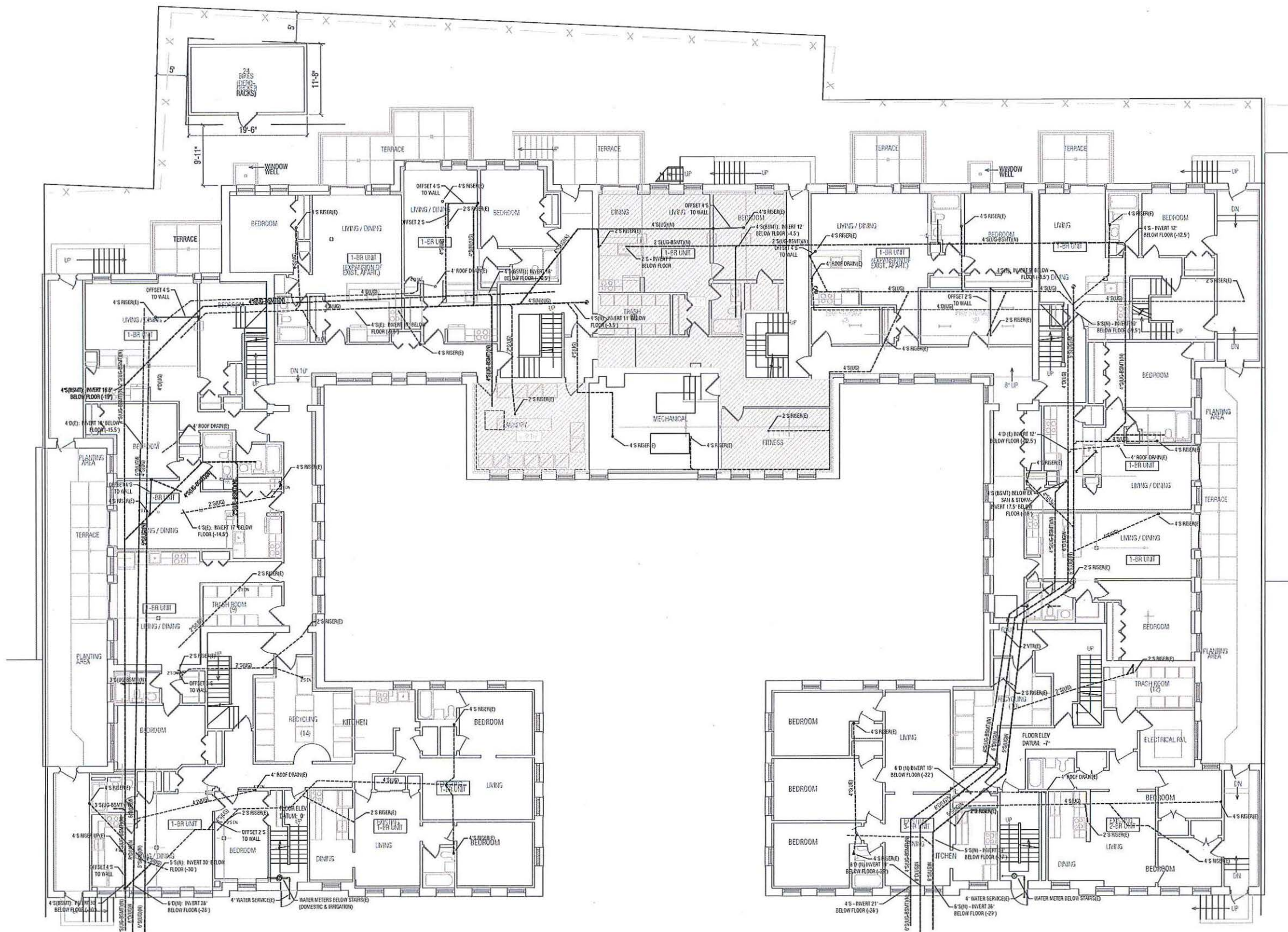

PROPOSED BASEMENT PLAN

SANITARY & STORM DRAINAGE - PROPOSED

NOTE: PROVIDE BACKWATER VALVES FOR ALL NEW BASEMENT PLUMBING FIXTURES

PROGRESS 8/4/15