

ATTACHMENT 4: Tree Study



CITY OF CAMBRIDGE, MASSACHUSETTS

PLANNING BOARD

CITY HALL ANNEX, 344 BROADWAY, CAMBRIDGE, MA 02139

CERTIFICATION OF RECEIPT OF PLANS BY CITY OF CAMBRIDGE TREE ARBORIST

City Department/Office: Department of Public Works/ Urban Forestry

Project Address: Mass + Main

Applicant Name: Twining Properties

For the purpose of fulfilling the requirements of Section 4.26, 19.20 or 11.10 of the Cambridge Zoning Ordinance, this is to certify that this Department is in receipt of the application documents submitted to the Planning Board for approval of a MultiFamily, Project Review or Townhouse Special Permit for the above referenced development project: a Tree Study which shall include (a) Tree Survey, (b) Tree Protection Plan and if applicable, (c) Mitigation Plan, twenty one days before the Special Permit application to Community Development.

7-15-16

Signature of City Department/Office Representative

Date

MASS + MAIN
Existing Tree Inventory

| # | Species | Common Name | DBH (inches) | Public or Private | Significant Private | Height | Condition | Status | Notes |
|-------------------------------------|-----------------------|-------------------|--------------|-------------------|---------------------|--------|-----------|---------|--------------------------------------|
| 1 | Acer rubrum | Red Maple | 10 | Public | | 15' | Very poor | Replace | Severe trunk scarring, crown dieback |
| 2 | Platanus x acerifolia | London Plane | 8 | Public | | 25' | Fair | Protect | Minor scarring, protect |
| 3 | Acer rubrum | Red Maple | 6 | Public | | 25' | Poor | Replace | Crown dieback |
| 4 | Pyrus calleryana | Callery Pear | 8 | Public | | 25' | Poor | Replace | Crown dieback |
| 5 | Acer rubrum | Red Maple | 10 | Public | | 25' | Very poor | Replace | Severe crown dieback |
| 6 | Pyrus calleryana | Callery Pear | 6 | Public | | 20' | Fair | Replace | Limited growth potential |
| 7 | Tilia cordata | Littleleaf Linden | 4 | Public | | 15' | Poor | Replace | Moderate scarring |
| 8 | Malus sp. | Crabapple | 6 | Public | | 15' | Fair | Protect | Limited growth potential |
| 9 | Tilia cordata | Littleleaf Linden | 6 | Public | | 15' | Fair | Replace | Limited growth potential |
| 10 | Malus sp. | Crabapple | 6 | Public | | 15' | Fair | Replace | Limited growth potential |
| 11 | Malus sp. | Crabapple | 6 | Public | | 15' | Poor | Replace | Limited growth potential |
| 12 | Pyrus calleryana | Callery Pear | 12 | Private | Y | 25' | Fair | Remove | Future development site |
| 13 | Pyrus calleryana | Callery Pear | 10 | Private | Y | 25' | Poor | Remove | Future development site |
| 14 | Pyrus calleryana | Callery Pear | 12 | Private | Y | 25' | Fair | Remove | Future development site |
| 15 | Quercus sp. | Oak | 3 | Public | | 15' | Good | Protect | Good health, protect |
| 16 | Acer rubrum | Red Maple | 4 | Public | | 15' | Good | Protect | Good health, protect |
| 17 | Acer rubrum | Red Maple | 4 | Public | | 15' | Good | Protect | Good health, protect |
| 18 | Acer rubrum | Red Maple | 4 | Public | | 15' | Good | Protect | Good health, protect |
| 19 | Fraxinus sp. | Ash | 17 | Public | | 30' | Good | Pending | Status pending DPW recommendation |
| Total DBH Private Significant Trees | | | 34 | | | | | | |
| Total DBH Public Trees | | | 75 | | | | | | |

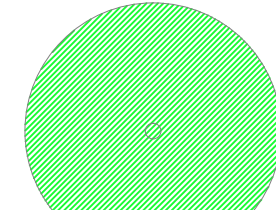
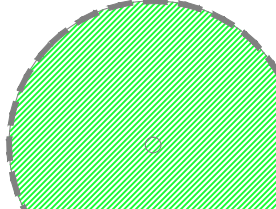
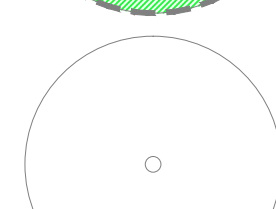

LEGEND

-  EXISTING SURVEYED TREE
-  EXISTING SURVEYED SIGNIFICANT TREE
-  EXISTING UNSURVEYED TREE (UNAFFECTED BY CONSTRUCTION)

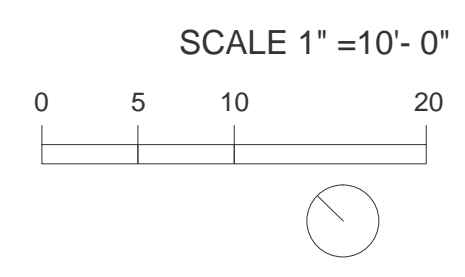

MASS + MAIN
Existing Tree Inventory

| # | Species | Common Name | DBH (inches) | Public or Private | Significant Private | Height | Condition | Status | Notes |
|-------------------------------------|----------------------------|-------------------|--------------|-------------------|---------------------|--------|-----------|---------|--------------------------------------|
| 1 | <i>Acer rubrum</i> | Red Maple | 10 | Public | | 15' | Very poor | Replace | Severe trunk scarring, crown dieback |
| 2 | <i>Platanus acerifolia</i> | London Plane | 8 | Public | | 25' | Poor | Replace | Crown dieback |
| 3 | <i>Acer rubrum</i> | Red Maple | 6 | Public | | 25' | Poor | Replace | Crown dieback |
| 4 | <i>Pyrus calleryana</i> | Callery Pear | 6 | Public | | 25' | Poor | Replace | Crown dieback |
| 5 | <i>Acer rubrum</i> | Red Maple | 10 | Public | | 25' | Very poor | Replace | Severe crown dieback |
| 6 | <i>Pyrus calleryana</i> | Callery Pear | 6 | Public | | 20' | Fair | Replace | Limited growth potential |
| 7 | <i>Tilia cordata</i> | Littleleaf Linden | 4 | Public | | 15' | Poor | Replace | Moderate scarring |
| 8 | <i>Malus sp.</i> | Crabapple | 6 | Public | | 15' | Fair | Replace | Limited growth potential |
| 9 | <i>Tilia cordata</i> | Littleleaf Linden | 6 | Public | | 15' | Fair | Replace | Limited growth potential |
| 10 | <i>Malus sp.</i> | Crabapple | 6 | Public | | 15' | Fair | Replace | Limited growth potential |
| 11 | <i>Malus sp.</i> | Crabapple | 6 | Public | | 15' | Poor | Replace | Limited growth potential |
| 12 | <i>Pyrus calleryana</i> | Callery Pear | 12 | Private | Y | 25' | Fair | Remove | Future development site |
| 13 | <i>Pyrus calleryana</i> | Callery Pear | 10 | Private | Y | 25' | Poor | Remove | Future development site |
| 14 | <i>Pyrus calleryana</i> | Callery Pear | 12 | Private | Y | 25' | Fair | Remove | Future development site |
| 15 | <i>Quercus sp.</i> | Oak | 3 | Public | | 15' | Good | Protect | Good health, protect |
| 16 | <i>Acer rubrum</i> | Red Maple | 4 | Public | | 15' | Good | Protect | Good health, protect |
| 17 | <i>Acer rubrum</i> | Red Maple | 4 | Public | | 15' | Good | Protect | Good health, protect |
| 18 | <i>Acer rubrum</i> | Red Maple | 4 | Public | | 15' | Good | Protect | Good health, protect |
| 19 | <i>Fraxinus sp.</i> | Ash | 17 | Public | | 30' | Good | Pending | Status pending DPW recommendation |
| Total DBH Private Significant Trees | | | 34 | | | | | | |
| Total DBH Public Trees | | | 75 | | | | | | |

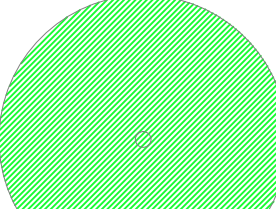
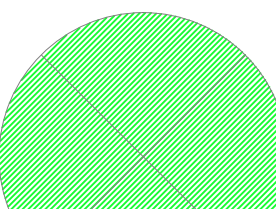
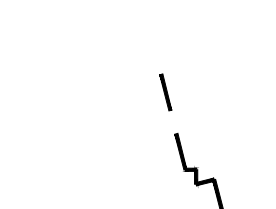
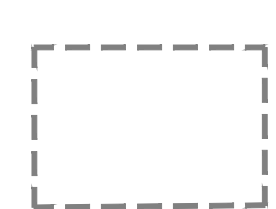

LEGEND

-  PROPOSED TREE REMOVAL
-  PROPOSED TREE TO RETAIN
-  FUTURE BUILDING FOOTPRINT
-  TREE PROTECTION ZONE

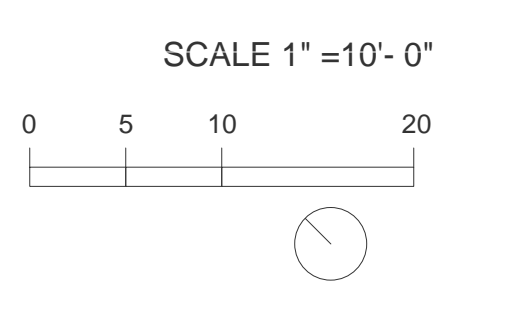



- LANDSCAPE NOTES**
1. FIFTEEN INCHES (15") OF TREES CALIPER TO BE REPLANTED ON PRIVATE PROPERTY.
 2. SEVENTY-ONE INCHES (71") OF TREE CALIPER TO BE REPLANTED ON STREETScape.
 3. AT LEAST THREE INCHES (3") OF TREE CALIPER IN THE LOT 6.
 4. TREES WILL BE INSPECTED AND, IF NECESSARY, TREATED BY A CERTIFIED ARBORIST ONCE A YEAR FOR FIVE YEARS.



mass + main
L099 PROPOSED LAYOUT
DATE: 2016.09.02

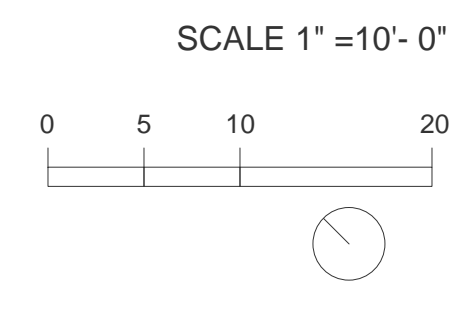

EXISTING *P. acerifolia*
(10) 4" CALIPER TREES IN 6" RAISED BEDS