

SECTION 02910

TREE PLANTING

PART 1 – GENERAL

1.01 SCOPE OF WORK

A. General:

1. Work shall consist of furnishing all labor, materials, equipment and transportation required to complete all the planting work in strict accordance with these specifications and applicable drawings. Work shall include, but not be limited to:
 - a. Submitting samples of materials and analyses for approval.
 - b. Securing necessary permits and approvals.
 - c. Back filling with suitable material within tree planting area.
 - d. Installing trees
 - e. Furnishing specified plant materials for installation and all necessary planting operations including mulching, watering, staking, guying, spraying, weeding, pruning, drip bag installation, etc.
 - f. Fertilization at the time of planting.
 - g. Establishing finished grades.
 - h. Cleaning site at end of planting operations.
 - i. Maintaining, protecting, weeding, pruning damaged or broken limbs, and replacing dead trees during the guarantee period.
2. Planting will take place throughout the City at various locations, primarily on City property along streets and other City owned land. Planting on private property within 20' feet of Right-of-Way may be required as well.
3. The City anticipates the planting work will primarily take place during the Spring and Fall planting seasons. On occasion plantings may take place outside of these times.
 - a. Spring: April 1st – June 15th
 - b. Fall: September 15th – November 30th
4. The City of Cambridge reserves the right to work with its own work force or other Contractor(s) as necessary.
5. The City does not guarantee the locations of existing pipes or underground conduits. The locations of these structures shown on City engineering plans are approximate. In private and public lands where sprinkler systems, driveways, walks, steps, walls and heating cables and or heating pipes are encountered, the Contractor shall use due caution when excavating in the vicinity of these structures and will be required to repair any damages caused at the Contractor's expense.
6. The City will provide plant materials as well as requesting the Contractor to provide plant materials as outlined on the bid form and in this document.
7. The tree planting will be performed by the requirements of the Contract Documents and will be directed by the City Arborist. The Arborist will instruct the Contractor if

changes need to be made due to any omission, contractual or otherwise, being noticed during the planting operation.

8. All work shall be done in a safe and workman-like manner, in compliance with the rules and regulations of the Division of Industrial Safety and all other City and State agencies and authorities having jurisdiction of the types of work included in this Contract.
9. A Massachusetts Certified Arborist or ISA Certified Arborist will carry out the planting of City of Cambridge Public Shade Trees. These persons will be at the work site for all planting operations. Names of Massachusetts Certified Arborist (MCA), International Society of Arboriculture Certified Arborist (ISA) or equivalent will be submitted and approved by the City Arborist before any planting occurs.

B. Powers and Duties of the City Arborist

1. For the purposes of the contract, the City of Cambridge is acting through its City Arborist who, by delegation and local ordinance, has control over and is responsible for the care and removal of all trees on City streets, playgrounds, schools, recreation lands and conservation land. The City Arborist also performs the function of Tree Warden, in accordance with the Massachusetts General Laws, Chapter 87 entitled "Shade Trees", has authority over, control and supervision of all trees which now or which may hereafter exist upon any public street or highway in this City, and over all trees which exist upon any private property in this City, when such trees are in such hazardous condition as to affect adversely the public health, safety, and welfare. The term City Arborist shall mean City Arborist or his/her designee.
2. In the exercise of all or any of the powers herein granted, the City Arborist shall have the authority to delegate all or any part of his/her powers and duties with respect to the supervision and control of this contract to his/her subordinates and assistants in the employ of the City of Cambridge as he/she may determine.

1.02 (NOT USED)

1.03 APPLICABLE STANDARDS

- A. American National Standards Institute (ANSI): Standard A300-2008 Standard Practices for Tree Care Operations – Tree, Shrub and Other Woody Plant Maintenance
- B. American National Standards Institute (ANSI): Standard Z-133.1.-2006 Safety Requirements for Tree Care Operations – Pruning, Trimming, Repairing, Maintaining, and Removing Trees, and Cutting Brush
- C. All other applicable Occupational Safety and Health Administration (OSHA) standards, and state and local regulations.
- D. American National Standards Institute (ANSI): Standard Z60.1-2004 or current edition.
- E. American Standard for Nursery Stock, published by the American Association of Nurserymen
- F. American National Standards Institute- (ANSI) is the private, non-profit organization that administers the safety and maintenance regulations for the Tree Care Industry.

1.04 DEFINITIONS

- A. Whenever used in any of the Contract Documents, the following meanings shall be given to the terms herein defined:
1. The term "Contract" means the agreement executed by the Owner and the Contractor, consisting of these Contract Documents.
 2. The term "Owner" means the City of Cambridge acting through its authorized representative, the Commissioner of Public Works, whose responsibility it shall be to coordinate review and approval by City, State and Federal departments and agencies which have jurisdiction over the various types of work to be carried out under this Contract.
 3. The term "Public Works Department (PWD)" means those persons employed by the Commissioner of Public Works for the purpose of directing or having charge of the work of this Contract or a portion thereof, limited by the particular duties entrusted to that person.
 4. The term "Local Public Agency" means the Public Works Department.
 5. The term "Awarding Authority" means the Public Works Department.
 6. The term "Contractor" means the person, firm or corporation entering into the Contract with the Owner to construct and install improvements embraced in this Contract.
 7. The term "Contract Documents" means and shall include the following: Invitation to Bid; Bid Requirements; Contract Forms; Bonds and Certificates; Conditions of Contract; Addenda; if any; Technical Specifications; and Drawings.
 8. The words "required", "permitted", "ordered", "designated", "prescribed", or words of like import shall mean the direction, requirement, permission, order, designation, prescription, etc. of the Owner or the Owner's representatives, and similarly, the words "approved", "acceptable", "satisfactory", or words of like import, shall mean approved by, or acceptable or satisfactory to the Owner's authorized representative, subject in each case to the final determination of the Owner unless otherwise expressly stated.
 9. The terms "City" means the City of Cambridge, Massachusetts, within which the work of this Contract is to be carried out.
 10. The term "MHD Standard Specifications" or "Standard Specifications" refers to the latest edition of the Massachusetts Highway Department Standard Specifications for Highways and Bridges, including supplements and amendments.
 11. Bare Root – a tree or shrub with minimal or no soil surrounding the roots of a plant.
 12. Balled and Burlap (B&B) – a tree or shrub with soil containing the roots of a plant. Soil is covered by a natural or synthetic burlap material and may have a wire mesh cage around the root ball.
 13. Certified Arborist – an individual who has passed and currently maintains an arborist certification with the International Society of Arboriculture, Massachusetts Arborist Association or equivalent. Arborist certification shall require continuing education units (CEU's) in order to maintain certification.
 14. Container grown – a tree or shrub with a synthetic material or pot containing its roots.
 15. Contract Supervisor- the individual or designated representative responsible for insuring the requirements of this contract are adhered to.
 16. Caliper - The measure of a plant's trunk. - Caliper measurement of the trunk shall be taken six inches above the ground up to and including four-inch caliper size. If the caliper

at six inches above the ground exceeds four inches, the caliper should be measured at 12 inches above the ground. Caliper will be measured to the nearest full inch.

17. Occupational Safety & Health Administration- (OSHA) is the Federal agency responsible for insuring worker safety.

1.05 SAMPLES AND SUBMITTALS

- A. Upon award of the contract and at least thirty (30) days prior to intended use, the Contractor shall provide the following samples and submittals for approval. Do not order materials until Contract Supervisor's approval of submittal has been obtained. Delivered materials shall closely match the approved samples. Should the source of supply be changed within the course of the contract, the Contractor shall submit new samples or submittals for approval per the original submission.
- B. Soils and Soil Management: Contractor shall make the following submittals and perform the following testing program on all on-site soils to be reused as backfill and on all off site borrow soils and material placed on the project. The cost of all submittals and testing stated below shall be incidental to the work and paid for by the Contractor.
1. Independent Laboratory and Testing Company. Submit 4 weeks prior to start of excavation, evidence that the Laboratory/testing company is:
 - a. accredited by the American Associates of the State Highway and Transportation Officials (AASHTO)
 - b. Has minimum 3 years' experience in sampling, testing and analysis of soil and aggregates, and monitoring field compaction operations.
 - c. Able to provide 3 references from previous work.
 2. Submit to the City and the Engineer grain size analysis curve (ASTM D422) and compaction test results (ASTM D1557) for each proposed source of backfill including suitable on-site soil to be reused as backfill, for review two weeks prior to use of the material. Grain size analysis shall indicate that the backfill material conforms to the gradation requirements specified.
 3. Contaminant analysis for off-site borrow materials used. Each material imported shall be accompanied by a certification statement and analytical results. At a minimum, the certification shall state that the point of origin and that the material is free of contaminants. The certification shall include representative sample analysis from each point of origin of backfill to be used on the site. The samples shall be analyzed by a certified laboratory for total metals (EPA priority pollutant metals), volatile organic compounds (EPA Method 8270), petroleum hydrocarbons (EPA method 418.1), and Total PCB's and pesticides (EPA Method 8081 and 8082). On site soils designated as suitable for reuse can be reused as backfill without providing certification required above.
 4. Contractor shall, in coordination with Soil Management Plan, submit to the City Arborist and the City an Excavation, Backfilling, and Filling Plan at least 2 weeks prior to earth moving activities. The review will be only for the information of the City for an overall understanding of the project sequence and site utilization. The contractor shall remain responsible for the adequacy and safety of the means, methods, and sequencing of construction. The plan shall include but not be limited to the following items:

- a. Detailed sequence of work
 - b. General description of construction methods
 - c. Number and location of crews and equipment and manpower to be deployed
 - d. Traffic, bicycle and pedestrian management
 - e. Proposed location of stockpiles
 - f. Proposed locations and sequence of test pitting for soil testing and utility installations prior to the start of water pipe, drain, sewer and utility installations.
 - g. Maintenance and continued operation of existing infrastructure.
- C. Planting soil: At least 30 days prior to ordering materials, the Contractor shall submit to the Owner's Representative representative samples, certifications, manufacturer's literature and certified test results for proposed planting soil.
 - D. Names of Massachusetts Certified Arborist (MCA) or Massachusetts Certified Nurserymen (MCN) will be submitted and approved by the City Arborist before any planting occurs.
 - E. Mycorrhizal Fungal Transplant Inoculant with hydrogel: Submit one (1) sample packet showing composition and analysis for fertilizer, also submit invoices of total purchased material for this contract.
 - F. Structural Planting Medium: At least 30 days prior to ordering materials, the Contractor shall submit to the Owner's Representative representative samples, certifications, manufacturer's literature and certified test results for proposed structural planting medium.
 - G. Fertilizer: Submit one (1) sample packet of fertilizer showing composition and analysis for fertilizer, also submit invoices of total purchased material for this contract.
 - H. Drip irrigation bag product: Product literature.
 - I. Planting Mulch: Submit a one- (1) cubic foot sample.
 - J. Stakes and ties: Product literature and sample
 - K. Edging: Product literature and sample
 - L. Certify, invoice, and order plants for each shipment grown, free of disease and insect pests. Submit certificates to Engineer.

1.06 QUALITY ASSURANCE

A. General Personnel Requirements:

- 1. Horticulturally skilled workers, trained and experienced in accepted nursery and arboriculture practices shall perform the planting. The work shall be done in a workmanlike manner under the supervision of a qualified planting supervisor demonstrating a background in landscape operations. It is required that the planting supervisor be a Massachusetts Certified Arborist, I.S.A. Certified Arborist or

equivalent pending the City Arborist's approval and as defined in Section 1.04.A.13.

2. The Contractor shall supply sufficient personnel to perform the work in accordance with the applicable specifications and conditions listed herein. The Contractor shall employ only qualified, competent personnel to do the work; and whenever the City shall notify the Contractor in writing, that a person in charge of, or on the work site, is not working in a workmanlike manner or is incompetent, unfaithful, disorderly, unsafe, under the influence of liquor and/or drugs, using insolent or improper language or is otherwise unsatisfactory in any manner, or not employed in accordance with the provisions of this contract, such persons shall no longer be assigned by the Contractor to perform work called for under the terms of this contract. The Contractor is responsible for administering any drug/ alcohol testing of his/her employees as required by State and Federal agencies. The Contractor must inform the City with proper documentation that such random testing was performed.
3. All Contractor personnel shall be dressed and be provided by the Contractor suitable work and safety clothing at all times. Clothing must contain the Contractor's name and logo making them identifiable to the public.
4. The Contractor shall provide his/her employees with all safety belts, helmets, eye and hearing protection and any other equipment defined as safety items by OSHA and ANSI.
5. Each worker shall be experienced and highly qualified with necessary planting work skills to successfully complete this contract. Said skills shall also include worker safety and ability to be in compliance with current OSHA and ANSI standards.
6. In the event that the Contractor and/or his/her employees are found to be in violation of applicable safety requirements, the Contractor will be so notified by the City Arborist or persons designated by him, and said person(s) may order that work be stopped until any and all such violations are corrected.
7. The Contractor and his/her employees shall at all times conduct themselves in an appropriate manner. The City expects that all employees of the Contractor will interact with the public in a polite and professional manor. If the Contractor or his/her employees are not able to answer a question or satisfy a citizen request, then the Contractor shall promptly refer the citizen to the City Arborist as well as contact the City Arborist right away to report the nature of the citizen's inquiry.

B. Equipment Requirements

1. The equipment used for tree planting shall be of sufficient type, capacity and quantity to safely and efficiently perform the tree planting work as specified.
2. All equipment (including support equipment) to be used by the Contractor shall be listed on the Contractor's Information Report at the time of the bid opening. All such equipment can be subject to the inspection and final approval of the City Arborist. Such approval may require on-site demonstration of the capability of any proposed equipment to provide satisfactory performance.
3. All vehicles used by the Contractor shall comply with safety standards established by the Department of Transportation in the State they are registered pertaining to the operation and transportation of equipment on public and private ways. All vehicles shall be equipped with required equipment and safety equipment.

4. All crews must be equipped with cellular phones to facilitate direct communication between the City Arborist and the work crews. The cell phone shall also be equipped with a text and voice mail function. A beeper/pager is not an acceptable means of communication with the City Arborist.
5. Each of the Contractor's vehicles used in the performance of the work required of this contract shall be lettered and numbered with removable signs, one on each side, colored white with black lettering to be sized approximately three feet by two feet. It shall contain the following text: City of Cambridge Urban Forestry (617) 349-4885 cambridgetree@cambridgema.gov". It will also contain the logo of the Urban Forestry Division. The format and method of providing the logo will be worked out at the time of contract award. Upon completion of the contract these signs are to be turned in to the City.
6. While working for the City these signs must be on the trucks at all times. Failure to do so may result in nonpayment for those hours worked by the Contractor without the proper signage.
7. The Contractor shall remove all these signs from vehicles when the vehicles are not in service to the City of Cambridge under the terms of this contract.
8. In addition to all required safety cones and road safety devices each job site must have two "A frame" style signs approximately 3 feet tall and two feet wide. Each side of the signs shall be lettered and numbered with removable signs, one on each side, colored white with black lettering to be sized approximately three feet by two feet. It shall contain the following text: City of Cambridge Urban Forestry (617)349-4880 cambridgetree@cambridgema.gov". It will also contain the logo of the Urban Forestry Division. The format and method of providing the logo will be worked out at the time of contract award. These signs shall be placed on the sidewalk or other similar location on either side of the job site warning pedestrians of the work and displaying the nature of the work to the public. Upon completion of the contract these signs are to be turned in to the City.
9. The Contractor's vehicles and equipment shall at all times be clean and in good repair and kept in a sanitary condition.
10. The Contractor shall be aware that the City does not have parking available for any equipment. Should the Contractor require parking for its vehicles or personnel it will be up to the Contractor to find and pay for this parking.
11. The Contractor shall hold harmless and indemnify the City for all claims, including, but not limited to, claims for property damage and liability in connection with the parking of vehicles.
12. The Contractor shall notify the City immediately if any equipment is out of service and promptly notify the City once the equipment is back in service. The Contractor shall use all due diligence to promptly effect repairs to out of service equipment and/or to secure alternate equipment if necessary to effectively perform the work of this contract.
13. At the discretion of the City Arborist, if equipment failures, breakdowns or other related problems occur that are jeopardizing the execution of this contract the City will require the failed equipment be replaced. Failure to replace the equipment may result in the contract being terminated.
14. The Contractor shall not allow any operator to leave any vehicles/equipment unattended with the motor running.
15. All employees or agents of the Contractor who are assigned to drive in or operate

vehicles shall at all times possess and carry valid vehicle/operator's licenses, as applicable which are required for the operation of such vehicles.

C. Requirements Regarding Private Property

1. The normal access to a job site shall be along public roadways. Should work require the Contractor to place equipment and/or personnel on private property, the Contractor shall obtain the property owner's permission in writing and shall notify the City Arborist prior to the work. The City Arborist shall provide a permission/indemnification form to be used for this purpose.
2. The Contractor shall be required to deal directly with private citizens with respect to repairing and/or replacing damaged bushes, shrubs, and other damage to private property that may be caused by the Contractor in connection with work performed pursuant to this contract. A report in writing concerning such damage and action taken to correct the damages shall be given to the City Arborist of the Parks and Forestry Department.
3. The Contractor shall respond to the City Arborist within 24 hours in regards to all complaints of damage to private property alleged to have been caused by work performed by the Contractor. In case of such damage, the Contractor shall be required to make arrangements with the homeowner to remedy the damage. The Contractor shall make or effectuate any such repairs within thirty (30) days of the date of the damage, or within such additional times as agreed in writing between the Contractor and homeowner.
4. In order to assist the City in the processing of claims for property damage, the Contractor shall be, at the City's discretion, required to prepare a written report, on a form to be provided by the City Arborist, as to the condition of the tree in each instance when the Contractor removes a tree and/or limb which has damaged private property including automobiles and damage to residential and commercial property.
5. The Contractor shall provide written reports and respond to requests by the City Arborist and/or the City Solicitor's Office related to investigations of claims against the City for property damage and personal injuries claimed to be caused by incidents of falling trees or limbs including, wherever possible, reports of damage caused by trees that fall during storm conditions.

D. Work Scheduling and Hours

1. The City intends on having scheduled tree planting work twice a year, during the Fall planting season and the Spring planting season. However there may be other times during the year that the City will request that trees be planted. The City will make a list of planting location(s) in advance of the work for the Contractor.
2. Prior to the commencement of work the Contractor shall meet with the City Arborist and provide a written schedule for the completion of work. City Arborist requires that this schedule be closely adhered to. Any changes to the schedule must be submitted to the City Arborist in writing for approval.
3. The Contractor shall begin work upon receipt of written and/or verbal orders to begin such work, and the work once begun shall be continuously carried forward with a force of persons adequate in the opinion of the City Arborist to complete the work in a continuous, uninterrupted, reasonable and expeditious manner, increment

and unseasonable weather conditions excepted. In the event the City Arborist determines that the Contractor has not begun work on orders to do so, or that the work once begun has been abandoned without authority, then the City Arborist shall give the Contractor seventy-two (72) hours notice (Sunday excepted) to begin work, or resume work in case of abandonment. Failure of the Contractor to act within this specified time shall be deemed a breach of this contract and the Contractor shall be held liable for any damage or expense arising from such breach of contract.

4. Standard work hours shall be Monday through Friday from 7:00 AM to 3:30 PM. Any work outside of these hours must be approved by the City Arborist
5. The work crew(s) are to report daily to the City Arborist when they start and when they finish work for the day. Completed work locations are to be faxed or emailed on a daily basis to the City Arborist

E. General Standards

1. The Contractor's work shall be done in a workmanlike manner and performance thereof and all materials and facilities furnished by him/her shall be to the satisfaction of the City Arborist.
2. Approved plant locations shall be marked by the City. Contractor to have planting locations checked by Dig-Safe for utility conflicts before any excavation or pavement removal is started.
3. Any unexpected obstructions at the site that interfere with the tree planting operation will be communicated to the City Arborist to determine a solution before planting occurs. The Contractor will not be compensated for any planting adjustments not approved by the City Arborist.
4. All work areas shall be kept in such a manner so as to cause as little inconvenience as possible to the general public and adjacent property owners. When it is necessary to close pedestrian walks, vehicular traffic lanes or private access roads and drives, the Contractor shall provide personnel, barricades, warning signs, cones, flags or other means required by governing rules and ordinances, along with notifying the affected property owner or resident. Driveways are not to be blocked with debris at any time.
5. The Contractor shall obtain a permit from the Department of Public Works (permit desk telephone 617-349-4833) prior to any sidewalk or roadway obstruction. A copy of this permit must be available at the work site at all times. The Contractor is required to obtain street excavation and street obstruction permits to complete the work under this contract. Fees for permits to excavate or obstruct the public way shall be waived; all permits must be obtained prior to beginning work on the City streets and sidewalks. Permits will be required for each of the project components.
6. Scheduling Police Details shall be the responsibility of the Contractor. A Police Detail is to be present during all construction activity. To schedule a detail officer, call (617) 349-3350. The Cambridge Police Department requires 24-hour advance notice to obtain a Police Detail, except in emergencies and 4-hour advance notice to cancel a detail. The Contractor must submit all signed detail forms to the project managers or engineer, so that Public Works can pay all submitted and approved Police detail invoices. Any invoices that are not approved will be the responsibility of the Contractor to pay. The City of Cambridge Police Department shall bill the City of Cambridge Department of Public Works or whatever department has oversight of

the contract for the services of uniformed police officers provided by the Police department. The Contractor shall reimburse Public Works or any other department which has oversight of the contract for Police Details, if the Contractor fails to appear for the job or if the Contractor fails to cancel the detail with adequate advance notice.

7. Traffic plans and work zones shall be in accordance with the Manual of Uniform Traffic Control Devices (MUTCD) of the U.S. Department of Transportation.
8. Road closures, if necessary, must be approved by the City of Cambridge Traffic and Parking Department (telephone 617-349-4700) not less than 48 hours prior to the commencement of work.
9. The Contractor shall provide, erect and maintain all barricade warning signs, guards or other protection, as necessary and required for the safe execution of this Contract, and shall remove same upon completion of the work. No open tree pits shall be left unattended without safety and warning devices installed.
10. NO PARKING SIGNS- The Contractor shall post “TEMPORARY NO PARKING—TREE PLANTING” signs a minimum of forty-eight (48) hours in advance. The Contractor shall fill in the date, time and reason where indicated on the sign with a permanent, waterproof, black marker. The signs shall be placed in each location designated for tree service on any and all roadways prior to servicing the area. Signs shall be wired to trees, utility poles or city owned street signage. Both wire and sign shall be removed and disposed of by the Contractor when planting has been completed. Nails, tacks or staples are not allowed for attaching signs to trees. Only signs provided by the City shall be posted. Signs shall be purchased at the Permit Desk, 147 Hampshire St. at the cost of two (\$2.00) dollars per sign once the Contractor has been issued an obstruction permit. A posting report shall be filed with the Traffic and Parking Department a week in advance and updated in case of changes. Failure to submit a posting report with a copy to the Department of Public Works will result in an illegal posting. Any reimbursement to citizens for towing resulting from illegal posting shall be at the expense of the Contractor.
11. PERMITTING- It shall be the responsibility of the Contractor to apply for and receive the appropriate permits from Public Works and the Department of Parking and Traffic before the start of work.
12. Contractor shall mark each sign with the date, time of parking restriction and reason for restriction where indicated with a permanent, waterproof black marker. The signs shall be removed immediately after the work is completed.
13. Traffic control flashers, lights, and arrow boards shall be either solar or battery powered.
14. Contractor is required to maintain all work areas in a safe fashion, especially during times when a police detail is not required. The Contractor will set up all necessary caution signs, high visibility flags, traffic cones, etc., at all times while working in the City.
15. All wood, brush and debris must be disposed of properly and in compliance with the requirements as pursuant to the provisions contained herein. Any debris left must not block vehicular or pedestrian traffic, and/or access to homes, or other private or public property (except as otherwise directed by the City Arborist).
16. Contractor shall carefully protect against damage to all existing trees and plants. The Contractor shall be liable for any and all damage to such trees, plants, real property and vehicles, and shall replace, repair, restore or provide for returning the same to their original condition, to the satisfaction of the City Arborist.

17. Contractor will not leave any excavated areas left open after securing his/her work site at the end of each day. The Contractor is responsible for barricading and cautioning off such open excavated areas before leaving the work site. The City Arborist may require the Contractor to cover over or backfill such excavated areas in reference to the safety of the general public.
18. Contractor shall clean up the entire project before the work will be accepted. All debris, rubbish, boulders from any excavation material and etc., unless specifically ordered by the City Arborist to do otherwise, or any other debris shall be disposed of by the Contractor. The entire area within the easements and all other areas disturbed by the Contractor shall be graded and left in a condition comparable to that as found originally and satisfactory to the City Arborist.
19. Contractor shall make no excavation in any public way or utility easement unless at least seventy-two (72) hours, exclusive of Saturdays, Sundays and legal holidays, before the proposed excavation is to be made, he/she has given notice in writing by registered mail if deemed necessary by the Contract Supervisor, of the proposed excavation to such public utility companies as supply gas, electricity and telephone service in the City, to such private companies as supply cable television service in the City and also to the City of Cambridge Water Department. Such notice shall set forth the name of the street and a reasonably accurate description of the location in which the excavation is to be made. The Contractor shall comply with DIG SAFE LAW (G.I.C. 82, Sec 40).
20. Contractor shall exercise the greatest care to ensure that no material being hauled by the Contractor or Sub-Contractor either to or from the site is spilled onto any way, public or private way, within the City limits. In the event that such spillage does occur, it shall be the Contractor's responsibility to remove the spilled material and clean the area promptly but in no event any later than the end of the workday. If in the judgment of the City Arborist, the Contractor has not satisfactorily cleaned the area of any spill, the City Arborist may then order the area to be cleaned by the City at the Contractor's expense.
21. Contractor shall furnish all the labor, materials, tools and equipment necessary to do all the work required for the completion of each item as specified.

F. Special Provisions

1. All work areas near and around the tree planting areas resurfaced by the Contractor shall be guaranteed against settlement, upheaval or failure of any kind for a period of two (2) years after the City accepts the work and Contractor shall replace such resurfacing at their own expense. The City Arborist and or the City's Engineering Department, shall be the sole judge as to what constitutes a failure and which portion of the resurfacing is to be replaced, and his/her decision will be final.
2. Before starting the work and from time to time during the project's progress, as the City Arborist or the City's Engineering Department may request, the Contractor shall submit to him/her or them a written description of the methods he/she plans to use in doing the work and the various steps he/she intends to take.
3. Contractor shall cooperate with any other Contractors, utility companies and or City of Cambridge that may be working at or near this project's work site covered by this contract. The City Arborist and or the City's Engineering Department, will decide as to the respective rights of the parties involved and their decisions shall be final.

4. Contractor shall review all Contract Documents and verify all existing field conditions and report any discrepancies immediately to the Owner’s Representative prior to starting work. The starting of work indicates the Contractor has reviewed and accepted the Contract Documents and existing conditions.
5. Contractor shall rebuild, repair, restore and make good any and all damages to any portion of the work occurring prior to completion and final acceptance of the work, and shall bear the expense thereof.

PART 2 – PRODUCTS

2.01 PLANTING SOILS

- A. Contractor shall provide all topsoil required to complete the planting operation. Planting soil shall be a natural, fertile, friable loam typical of cultivated topsoil of the locality, containing at least 10% and not more than 20% decayed organic matter (humus). Topsoil shall be free of sub-soil, stones greater than one and one-quarter inches, earth clods, sticks, stumps, clay lumps, roots, or other objectionable, extraneous matter or debris. Topsoil shall not be by test either excessively acid or alkaline nor contain toxic substances. Topsoil shall not be delivered or used for planting while in a frozen or muddy condition.
- B. Soil for planting trees shall be one of the following sandy loams; “course sandy loam “, “sandy loam”, and “fine sandy loam”: determined by mechanical analysis (ASTM D 422) and based on the "USDA Classification System" and as defined in this Section. It shall be of uniform composition, without admixture of subsoil. Planting soil for trees shall have the following grain size distribution for material passing the #10 sieve:

<u>Millimeter</u>	<u>Percent Passing by Weight</u>	
	<u>Maximum</u>	<u>Minimum</u>
2	-----	100
1	100	80
0.5	87	67
0.25	78	48
0.10	68	30
0.05	55	22
0.002	7	2

1. Maximum size shall be one and one quarter inches largest dimension. The maximum retained on the #10 sieve shall be 25% by weight of the total sample.
2. The ratio of the particle size for 80% passing (D80) to the particle size for 30% passing (D30) shall be 6.0 or less. (D80/D30 < 6.0)

- C. Name of planting soil supplier and sample to be approved by the City Arborist.

2.02 (NOT USED)

2.03 FERTILIZER

- A. Fertilizer shall be a complete, slow-release, root contact packet, 16-8-16, or equal, that is engineered to stimulate root growth and is a standard product complying with State and Federal Fertilizer Laws.
- B. Name of supplier and sample to be approved by the City Arborist.

2.04 WATER

- A. Water furnished by the Contractor will be free of ingredients harmful to humans and plant life. The Contractor will supply hoses and other watering equipment required for the work.
- B. The Contractor shall be responsible to furnish its own supply of water to the site.
- C. Contractor may get water from a City of Cambridge fire hydrant only with the approval of the City's Water Department. The Contractor will be responsible for following all the procedures and requirements set by the Water Department. The Water Department will provide the Contractor with a meter and/or backflow device and will charge the Contractor a fee for the water and meter and/or backflow device. It is the responsibility of the Contractor to obtain this information. The Cambridge Water Department can be reached at 617-349-4025.
- D. Watering for trees shall be provided through use of a drip irrigation type bag which shall be approved by the City Arborist.
 - 1. To be constructed of a flexible watertight material
 - 2. Holding capacity of a minimum of 20 gallons
 - 3. Must have opening in top for filling.
 - 4. Must have small holes in bottom that slowly releases water
 - 5. Rate of complete water release must be no quicker than 5 hour following complete fill.
- E. Name of drip irrigation bag product, supplier and sample to be approved by the City Arborist.

2.05 MULCH

- A. Mulch shall be high quality, shredded or double-ground, premium bark mulch consisting of clean, organic plant material.
- B. Shall be uniform in color, a good brown color. The composition of the shredded pine bark material shall not exhibit a noticeable degree of any color change characteristics when wet.
- C. The mulch must be free of dirt, insects, disease and extraneous debris that would be harmful to all trees being installed.
- D. The shredded pine bark mulch material shall not have an unpleasant odor.
- E. Bark Mulch shall be a well-graded material conforming to the following:

1. pH between 4.0 – 8.0
2. Particle size 100% passing a 50mm (2 inch) screen
3. Soluble salt content < 4.0 mmhos/cm

- F. Prior to the Contractor ordering shredded pine bark mulch material, the Contractor shall submit to the City Arborist, at the Contractor's expense, one cubic foot sample of the shredded pine bark mulch material. The Contractor shall not order any delivery of the shredded pine bark mulch material until the Contractor's sample has been inspected and approved by the City Arborist.
- G. If the City Arborist disapproves of the sample submitted by the Contractor, then the Contractor shall continue at no expense to the City, to obtain other sources of pine bark mulch material as specified until the Contractor's sample of such material, meets with the City Arborist's approval.

2.06 STAKING

- A. Stakes will be wood, 10' x 2" x 3" in size, pointed at one end.
- B. Tree ties shall be black polyester straps. Both must be approved by the City Arborist.
- C. Samples of stakes and tree ties shall be submitted to the City Arborist for approval.

2.07 EDGING

- A. For new or expanded tree wells in brick sidewalks, the Contractor shall install edging around the perimeter of the tree well to keep the bricks from displacing.
- B. Aluminum edging shall be shop fabricated from aluminum alloy 6063-T6, 3/16 inch thick x 1-5/8 inch or 2-1/4 inch deep, with standard black baked-on acrylic paint finish. Edging shall be furnished in 16-foot lengths.
1. Adjacent sections shall be adjoined using a 4 inch sliding, locking connector of aluminum alloy 6063-T6.
 2. Stakes shall be spiral steel spikes with insulating plastic washers 10 inches x 3/8 inch.
- C. Name of edging product, supplier and sample to be approved by the City Arborist.

2.08 TREE PLANTING MATERIALS

- A. Plant Identification and Standards: The nomenclature used in the plant list generally conforms to that of the current edition of Standardized Plant Names, as adopted by the American Joint Committee on Horticultural Nomenclature. All tree plantings shall conform to the varieties and sizes specified in the Plant List, and to the code of standards set forth in the current edition of American Standard for Nursery Stock. Substitutions will not be permitted without the consent of the City Arborist.

B. Plant List: The Contractor shall supply the plants necessary to complete the work as intended. Where the size of a plant on the Plant List is a variation between a minimum and maximum dimension, the sizes of the plants furnished will be equal to the average of the two dimensions. Where a single dimension is given, this dimension represents the minimum size of the plants to be furnished.

C. General Trees:

1. All plants shall be nursery grown whether balled and burlapped or container grown, under climatic conditions similar to those in Cambridge, Massachusetts. The tree plantings shall be typical of their species and variety. Trees shall be straight, symmetrical with a crown having a persistent main leader, be growing from a single, healthy root system with no girdling roots. All tree plantings shall be sound and healthy free from defects, disfiguring knots, sun scald, and injuries or abrasions of the bark. They shall be free of plant diseases, pests, scale and all forms of infestations, and possess a normal balance between height and spread. Plants shall be matched as closely as possible where uniformity is required.
2. Trees shall be inspected at place of growth by the City Arborist and a representative of the Contractor for conformity in shape, proportion, symmetry, branching habit and character. Unless a tree clump is designated, the trunk of each tree shall be single and straight. Each tree shall be grown from a single un-mutilated crown of roots and shall have main leaders intact. Old abrasions and Pruning wounds over $\frac{3}{4}$ inch in diameter shall be completely callused over.
3. Tree Limb Structure: All limbs on large trees maturing over 30 feet must originate on the trunk at 7 feet above the top of root ball. Small trees maturing less than 30 feet must have limbs that start no lower than 5 feet. All trees will be selected by the City Arborist.

D. Substitutions: Substitutions will not be permitted. If, however, proof is submitted that a plant(s) is not obtainable or does not meet requirements of Specification, use of nearest equivalent size or variety will be considered. Plants larger than specified may be used at no increase in cost. Proposed substitutions must receive the written approval of the City Arborist. When sources for plants are located by the City Arborist, there will be no substitutions and those sources will be used. The City does not guarantee it will accept substitutions. The City will require that the Contractor try every means possible to obtain the specified trees.

E. Inspections: Plants shall be inspected, selected and tagged at place of growth by the City Arborist with the Contractor. Inspection and approval at the source(s) shall not waive the right of rejection for failure to meet other requirements during progress of work.

2.09 PLANT ROOT BALLS

A. All root balls shall conform to the size requirements specified for the proposed tree species and size at planting identified in the Plant List, and to the code of standards set forth in the current edition of American Standard for Nursery Stock.

- B. All tree plantings either balled and burlapped or container grown shall retain root systems as solid units. The diameter and depth of the balls of soil must be sufficient to encompass the fibrous and feeding root system necessary for the healthy development of each tree planting.
- C. The tree plantings and root balls shall remain intact as a unit during all operations. No tree planting shall be accepted when the ball of earth surrounding its roots has been badly cracked or broken, either before or during the process of planting.

2.10 PLANT LABELS

- A. Plant labels shall be provided by the Contractor for each tree and shall be durable, legible labels, stating the correct tree name and size, in weather resistant ink or embossed process lettering, and can be removed at end of Contract.

PART 3- EXECUTION

3.01 SAW CUTTING AND PAVEMENT REMOVAL

- A. Certain locations will require the removal of pavement to allow for the expansion and excavation of the planting holes. Pavement types may include cement, bituminous concrete and other similar substances.
- B. All areas where pavement will be removed will be marked in the field by white marking paint. All edges are to be cut with clean cuts using a saw and are to be straight as marked on the pavement.
- C. The Contractor shall be responsible for the legal disposal of all excavated pavement off site, at the Contractor's expense.
- D. All dust, debris and deposits (including any residue from wet-saw cutting) left behind from the cutting and excavating operation shall be cleaned up immediately following the installation of the tree.

3.02 TREE GRATE AND GUARD REMOVAL

- A. From time to time prior to the planting of trees and/or at locations with existing trees the City may require that metal tree grates and tree guards be removed. Removal shall be done in such a manner that does not damage an existing tree to remain with whatever tools and equipment the Contractor deems necessary and is approved by the Contract Supervisor.
- B. The legal disposal of the grate and/or guard shall be the sole responsibility of the Contractor. The City reserves the right to keep the grate and/or guard as it deems necessary.
- C. After removing the grate and/or guard each planting tree well is to be weeded and cleaned of all debris. Bark mulch is to be replaced in the tree well to a level that meets the surrounding grade/ sidewalk surface.

3.03 (NOT USED)

3.04 (NOT USED)

3.05 EDGING

- A. Edging shall be installed at perimeter of new and expanded tree pits that abut brick paving. Install edging with the base resting on the base and facing toward the brick paving and sidewalk. Set edging to the required alignment, straight and true and to the required elevation to ensure full paver restraint. Thread spike through insulating washer. Drive spikes into base until spike head firmly wedges washer against flange of aluminum edging.
 - 1. Edging shall be securely staked in required position. Stakes shall be driven every 12 inches in straight runs and into every support section in curved sections.
 - 2. Adjacent lengths shall be attached using manufacturer's standard connections according to manufacturer's published instructions.
 - 3. Edging shall be set plumb and vertical at required line and grade. Straight sections shall not be wavy; curved sections shall be smooth and shall have no kinks or sharp bends.

3.06 TREE PLANTING SEASON

- A. Tree planting can occur under normal, favorable weather conditions. Tree planting will not be permitted as determined by the City Arborist under adverse weather conditions such as when the ground is frozen or during extreme heat.
- B. The City anticipates the planting work will primarily take place during the Spring and Fall planting seasons. On occasion plantings may take place outside of these times.
 - 1. Spring: April 1st – June 15th
 - 2. Fall: September 15th – November 30th

3.07 TREE PLANT SELECTION

- A. The City Arborist will select and tag all specified tree planting material at the nursery locations.

3.08 PLANT MATERIAL HANDLING

- A. Plants shall be handled and transported so as to prevent damage of any sort including but not limited to breakage of branches, scraped or bruised trunk, or broken root ball and roots
- B. Plants shall be protected during storage, and transportation by watering, covering, as necessary to ensure their continued health and viability.
- C. Special care shall be taken to insure that the roots of bare root and balled and burlap trees are not damaged and not allowed to dry out during the course of a work day.

- D. Bare root and balled and burlap trees are to be placed on a trailer, truck or other equipment gently and in a manner that does not damage any portion of the tree. Once placed they are to be covered in such a manner that sun light does not shine on the roots of the plant and the branches are protected from wind damage.
- E. If it is determined that poor handling and neglect by the Contractor has caused a plant to die or fail to establish the Contractor shall be responsible for the cost of replacing the plant. Costs shall include the cost of purchase, cost to remove dead plant and cost to install new plant. Neglect may result in potential contract termination.

3.09 TREE PLANT DELIVERY

- A. The Contractor will inspect and approve all trees at the nursery(ies) prior to pick up. However, this does not alter the right of the City Arborist to inspect and reject unsuitable trees delivered to the planting site.
- B. When plants cannot be transported and planted immediately upon being dug they shall be stored and protected from desiccation and extremes in temperature by being heeled-in, watered, and covered.

3.10 TREE PLANT STORAGE

- A. Tree plantings shall be delivered to the Contractor's storage site and to the tree planting site in a well-watered and vigorous condition. All unplanted tree plantings shall be protected at all times from sun and drying winds. Care must be taken so as not to damage bark, break branches, or cause injury to the tree.
- B. Contractor may, with City Arborist or Golf Course Superintendent permission, utilize the Cambridge Municipal Golf Course as a staging area for all trees furnished and planted under this Contract, unloaded by the Contractor, and cared for by the Contractor until satisfactorily planted.
- C. Contractor shall provide the City Arborist with a schedule of tree pick-up. Tree pick-up shall be done prior to 9:00 a.m. at the golf course.
- D. All trees shall be stored in an upright position and grouped according to Genus, Species and 'cultivar' or 'variety'. Stored trees shall be mulched (enough to cover 2/3 of the root-ball and heavily watered twice a day to prevent wilt and undue stress to the trees).
- E. Bare root and balled and burlap trees are to be removed from the City's holding area on a daily bases. Only the plants that can be planted in the course of a normal work day should be removed from the holding area.
- F. Bare root and balled and burlap trees are held in a woodchip mulch while waiting to be planted and are watered regularly by the Contractor to maintain root health. The Contractor will be expected to remove the trees from this mulch prior to bringing the plants to the planting location. Care shall be taken to not damage any of the roots during the removal process. Damaged roots/ plants will be the responsibility of the Contractor.

- G. It is the Contractor's responsibility to determine the best method to insure that the roots of bare root and balled and burlap trees are not damaged and do not dry out during the course of the planting process.
- H. It is expected that bare root trees removed from the woodchip mulch will be immediately placed in large plastic bags provided by the City and left in these bags until immediately before installation.
- I. At no time shall the roots of bare root and balled and burlap trees be exposed to direct sunlight, wind and drying out. Plants are to be covered immediately after removal from the woodchip mulch and not uncovered until immediately prior to installation. While sitting waiting to be installed plants and associated roots must be covered and protected from light and drying out.
- J. Periodically throughout the day the roots of bare root trees are to be misted with water. The frequency for this misting will be determined by the City Arborist based on current weather conditions and plant needs.

3.11 GENERAL TREE PLANTING

- A. Prior to tree planting, the City Arborist will supply in writing to the Contractor specified tree planting locations showing the tree selected and approved.
- B. Immediately after planting, Contractor shall provide one informational door hanger to residence directly adjacent to new tree planting. Door hangers to be provided by the City of Cambridge.
- C. Tree planting areas may need pavement removal as required by the City Arborist. All materials excavated from the tree planting areas and considered detrimental to the growth of the trees, such as an existing tree or stump, sidewalk paving, rocks, sub-soil and debris, shall not be reused for fill or in the planting operation, and must be removed from the site.
- D. Any unexpected obstructions at the site that interfere with the tree planting operation will be communicated to the City Arborist to determine a solution before planting occurs.
- E. Soil of very poor quality or heavy clay encountered by the Contractor must be reported to the City Arborist for removal and amended as required.

3.12 PLANTING HOLE PREPARATION

- A. Remove all soil, where present, from above the root flare to expose the top-most root where it emerges from the trunk, and measure the distance between the top-most root and the bottom of the root ball or root mass.
- B. Hole shall be dug about 10% shallower than this depth and at least three times the width of the ball or in the case of bare root at least one foot further than the longest roots.
- C. Planting pits shall be excavated to the full width and length of the surface opening. In lawn areas, the planting area must be dug to the depth of the root-ball and 3 times the width.

- D. When planting holes are dug using mechanical means, i.e. backhoe, excavator, auger, etc., and the side walls of the pits become plastered or glazed, the plastered or glazed surface shall be properly scarified.
- E. Surplus excavation and unsuitable material from the planting holes shall be removed from the site and disposed of per Section 3.13 SOIL AND WASTE MANAGEMENT of this Specification.
- F. Upon approval of plant locations and pavement removal (where applicable), excavate existing soils and remove all trees and stumps 5" or under, and any other deleterious materials, as shown on the drawings and as specified herein. The Contractor must haul and legally dispose of excavated material off-site.
- G. The tree well will be cut based on the markings on the sidewalk. The dimensions of each tree well will be noted on the planting list given to the Contractor prior to the start of planting. Note: The initial list will not contain 100% of the planting sites for the season. The tree well must be excavated to its full extent. Acceptable material may be put back into tree well and amended as needed with approved planting soil. If excavated material cannot be reused refer to Section 3.13 SOIL AND WASTE MANAGEMENT for instruction.
- H. Planting pits will require a minimum of 4' of walking space for sidewalk pedestrian traffic.
- I. Planting wells and areas shall be approved by the City Arborist, or designee, before back filling.
- J. Tree wells shall be at least 16 square feet, 8'x2' or as directed by the City Arborist.

3.13 SOIL AND WASTE MANAGEMENT

- A. For guidelines and policies related to handling and disposal of contaminated soil please refer to the Department of Environmental Protection (DEP) Website at <http://www.mass.gov/eea/agencies/massdep/>.
- B. It is the objective of soil/fill management practices specified here to handle all soil/fill excavated during the course of this contract in a cost-effective manner and in accordance with applicable state and federal regulations. The Contractor shall reuse excavated materials, as approved by the City Arborist, prior to using imported fill in order to reduce the volume of material to be disposed off-site provided the material is geotechnically suitable as backfill and does not result in spreading contamination to other areas or other soil/fill strata.

Excavated soil/fill, which is displaced by planting of trees, may be used as backfill elsewhere on the project provided the soil/fill is geotechnically suitable and does not result in spreading contamination or degrade the environmental quality at the location of reuse. Imported backfill shall be used only as accepted by the City Arborist.

- C. Any soils which exhibit petroleum or chemical odor or visual indications of oil or hazardous materials shall be handled as potentially contaminated soils. Soil which does not have any

evidence of contamination can be reused within the *area of excavation*. Soil/fill which is staged and characterized can be reused within the *area of excavation* or elsewhere on site provided the material has equal or less contamination than the point where it is to be reused.

- E. Contaminated soil/fill (including petroleum-contaminated soil/fill) which cannot be reused on site shall be delivered within the City to a stockpile location to be determined by the City of Cambridge.
- F. Notification Procedures:
 - 1. In the event of an emergency, the Contractor shall contact the following entities at the earliest possible opportunity:
 - a. City's designated representatives.
 - b. City of Cambridge DPW
 - c. City of Cambridge Fire Department
 - d. City Arborist
 - e. MassDEP
 - 2. The Contractor shall prepare in advance of work activities a notification list, complete with phone numbers, addresses, and contact names for all parties to be notified (including, but not limited to, the parties listed above) in the event of an emergency.

3.14 TREE INSTALLATION

- A. Trees shall be plumb, faced to give best appearance, and planted at the center of the planting areas. If the Contractor is unable to install tree at proper grade and/or in center of tree well or designated planting location, the Contractor shall not install tree and contact City Arborist immediately.
- B. Trunk flare must be visible and free of adventitious roots.**
- C. Place the tree in the planting hole so that the top of the root ball where the trunk flare is visible is 1" above the established sidewalk level. If root flare is covered or set significantly higher (or lower) than 1" above sidewalk grade than the Contractor will not be paid for that tree until it is properly adjusted.
- D. Any non-degradable materials used in wrapping the root ball must be entirely and carefully removed so as not to disturb the roots. Cut and remove not less than 2/3 of burlap and wire basket from root ball. Carefully cut containers and remove plant balls keeping the root ball intact. All materials cut away from the root balls must be removed from the site. **DO NOT PULL WIRES OUT FROM UNDER THE ROOT BALL.**
- E. Remove top 2/3 of burlap off the root ball. **DO NOT PULL BURLAP OUT FROM UNDER THE ROOT BALL.** Cut and remove all rope. Remove all non-biodegradable root ball materials, if present.

3.15 FERTILIZING

- A. Insert approved slow-release plant packets, number according to the caliper of the tree with the approval of the City Arborist before back-filling.

3.16 BACK-FILLING

- A. Carefully backfill by hand the approved topsoil in layers and water each layer thoroughly to fill all voids and allow to settle. Finish back-filling to a depth that finished grade level at settlement will be at established sidewalk level.
 - 1. Fill hole about 1/3 full and gently slice a shovel down into the backfill 15 to 25 times all around the tree. Do NOT step firmly in the backfill soil because this could compact it and restrict root growth. Be careful not to damage the trunk or roots in the process.
 - 2. Water the first third of soil to settle and eliminate air pockets. Backfill the remainder of the tree well in layers not to exceed six 6 inches. Water soil to settle. Fill in any holes or depressions with additional backfill soil. When the hole is filled with soil the root ball should remain approximately 2 inches above the backfill soil. The top of the root ball is not to be covered by the backfill soil.
- B. Surround each tree with a shoulder of topsoil to form a temporary saucer, 3 inches deep and equal to the diameter of the planting hole.

3.17 WATERING (INSTALL THROUGH FINAL ACCEPTANCE)

- A. After bringing soil in the tree well to grade and forming the planting saucer, thoroughly soak the tree well by repeatedly filling the tree well with water to the full depth of the saucer, allowing the water to completely percolate into the soil between fillings.
- B. At the time of planting judiciously flood plants with water. The Contractor will also include in his base bid costs for watering trees twice a week exclusive of Saturdays, Sundays and holidays for a period of 30 days from the date of planting.
- C. Watering shall be provided through use of a drip irrigation bag which shall be furnished by the Contractor and installed immediately on each tree following planting per the manufacturer's instructions.
 - 1. Immediately following the planting of the tree, a drip irrigation bag is to be installed per the manufactures instructions.
 - 2. Drip irrigation bag is to be placed around one of the tree planting stakes and rotated so that the zipper faces away from the trunk of the tree with the stake in the middle of the bag.
 - 3. Drip irrigation bag is to be secured with a zip tie or similar locking device to avoid unwarranted removal
 - 4. At each subsequent watering the drip irrigation bag shall be moved to the

opposite tree stake and the process repeated. This bag rotation shall occur weekly throughout the duration of the Guarantee Period.

5. At the end of the watering period the Contractor shall remove all irrigation bags and deliver them neatly stacked to the Public Works Department for winter storage.

- D. The Contractor shall provide the City with a schedule of watering which will be performed showing which plants will be watered during the Guarantee Period.
- E. Watering shall be provided from May 15 through November 15 at the discretion of the City Arborist.
- F. The watering crew is to report to the City designated City Arborist, by phone or in person as to the locations they will be watering that day.
- G. All installed trees that are injured or damaged due to the lack of water, or the use of too much water, shall be the Contractor's responsibility to correct.
- H. The Contractor is to provide a watering truck and water as outlined in the Equipment section (Section 1.06.B) and Materials section (Section 2.04) of this Specification.

3.18 WATERING (2-YEAR GUARANTEE PERIOD)

- A. Watering during the 2-year Guarantee Period shall be performed as specified in Section 3.16 and shall occur a minimum of once per week (approx. 4x per month) or as acceptable to the City Arborist.
- B. Watering and maintenance during the Guarantee Period will be recorded and tracked utilizing the City's Asset Management System.
 1. Prior to watering under the guarantee period, the contractor shall be issued a tablet computer by the City. The tablet will be GPS equipped as specified herein for all watering crews during the guarantee period so that the Agency may contact individual crews to confirm their exact location.
 2. In order to quantify trees watered the watering crews will be required to update the work order established with the City's asset management system, at the time each tree is watered. The contractor will record a "Watering Task" using the City's asset management system.
 3. If a tree is dead or damaged and not watered, the Contractor shall notify the City Arborist immediately.
 4. Prior to the guarantee watering season, all crew members who will be using the watering tracking system must attend a training hosted by the City.
 5. Prior to the watering season, the Contractor and City Arborist will review all data uploaded during planting to ensure all trees have been inputted into the tree inventory and asset management system. Any trees that were not inputted into the tree inventory and asset management system must be inputted within five (5) days of written notification of

the Contractor.

- 6. The Contractor will not get credit for the required weekly watering if the watering crew fails to update the work order in the City’s asset management system.

3.19 MULCHING

- A. Apply a three inch layer of mulch (after settlement) around plants. This area shall be at six feet in diameter around the trunk of the plant, unless otherwise specified by the City Arborist.
- B. Mulch shall not come in contact with the trunk of the plant or the root flare. Mulch should be two to three inches from the trunk.
- C. Place mulch immediately after planting. No planting areas shall be left for any longer than thirty minutes without mulch. No mulch material shall be applied prior to the initial watering of plant.
- D. From time to time the City may require additional mulch at various tree locations and existing planting beds citywide. Mulch is to be applied as outlined in this section.
- E. When the City opts to mulch existing trees and planting beds the Contractor is to remove all existing unwanted vegetation (i.e. weeds) and debris.

3.20 STAKING

- A. Stake, guy and anchor immediately after planting of each tree. Equally space stakes and set parallel to structures, contours, paving or curbs. Set plants plumb and hold in position until the soil has been tamped solidly around the ball and/or roots. Place stakes to depth indicated and fasten to tree with approved strapping, with appropriate knot.
- B. Any stake or strap that becomes displaced or broken shall be reset or replaced promptly.
- C. Staking shall be of uniform height after being driven at an angle one foot below bottom of tree well and drawn vertical. Place stakes to avoid root damage and at reasonable and proper distance from trunk to prevent movement of tree and root system; tension on stakes and guy wires to be equal and at a slight angle away from tree.

<u>No. of Stakes</u>	<u>Size</u>	<u>Length Tree Size</u>
2	2" x 3" x 8'	From 1" caliper up to and including 3-1/2" caliper

- D. Stakes for supporting trees shall be of uniform size, 2" x 3" x 8', capable of standing in the ground at least two years.

3.21 PRUNING

- A. Prune only badly bruised, broken, or crossing limbs.

3.22 CLEAN UP

- A. Removal and Disposal of Tree and Woody Vegetation Debris

1. The Contractor shall be responsible for the immediate removal of all debris resulting from the work at each job site. Each job site is to be left in a condition equal or better than that which existed prior to the execution of work order. The Contractor shall be solely responsible for disposal of all tree debris.
2. The City reserves the right to retain all debris, chips and wood from work completed on City of Cambridge trees at no cost to the City. The City reserves the right to use this material in any way it sees fit.

- B. Restoration of work areas and cleanup

1. All areas damaged during the process of the work shall be the responsibility of the Contractor and who shall restore the disturbed and damaged areas to a condition satisfactory to the City Arborist. This may include, but not be limited to tilling, grading, paving, fertilizing, mulching, etc.
2. The Contractor shall also be responsible for any other damage caused by his or her process of work operations and shall dispose of all rubbish, excess soil, etc., as directed by the City Arborist, all of which shall be done at no expense to the City of Cambridge.

3.23 BACKFLOW PREVENTION DEVICES

- A. When hydrants are being used, the Cambridge Water System must be protected with backflow prevention devices as per Massachusetts Department of Environmental Protection (DEP) Regulations 310 CMR 22.22 and as per the Cambridge Water Department Cross Connection Control Program. Backflow prevention devices must also be used during sweet sweeping, sewer flushing, paving operations and hookups for any other purpose. The Cambridge Water Department can be reached at 617-349-4025.

3.24 EDUCATIONAL MATERIALS

- A. Contractor will place one (1) door hanger supplied by the City Arborist on the abutting property owner's door or front entry way.

3.25 MAINTENANCE

- A. Maintenance shall begin immediately after tree planting and shall continue until final inspection and acceptance. Maintenance will include: watering, re-mulching, weeding, repositioning stakes, removal of dead or broken limbs, maintaining the planting saucer, etc.

Watering by the Contractor for the remainder of the guarantee period should be at least once a week or as acceptable to the City Arborist.

- B. Complete removal of Rubber Hoses and Guy Wires: At the end of 1 year after planting, the Contractor shall remove from the site the rubber hoses and guy wires from all trees, at no additional charge to the City. Stakes shall remain in place for one additional year to anchor the watering device.
- C. Complete removal of Stakes: At the end of 2 years after planting (end of Guarantee Period) the Contractor shall remove from the site the stakes from all trees, at no additional charge to the City.

3.26 GUARANTEE

- A. Trees will be guaranteed for a minimum period of time of two (2) years after the initial acceptance. Trees planted in spring shall be alive and in satisfactory growth on June 1 of the second year after planting. If planted in the fall, trees shall be alive and in satisfactory growth on October 1 of the second year after planting.
- B. Tree care shall begin immediately after each plant is planted to ensure the viability of the tree throughout the Guarantee Period and shall include, but is not limited to, the following throughout the Guarantee Period.
 - 1. straightening
 - 2. watering
 - 3. mulch replacement
 - 4. weeding
 - 5. pruning
 - 6. treating for insect pests and diseases
- C. The City Arborist, at his discretion, may require the Contractor to address tree planting related issues as they develop.
- D. Plants shall be straightened, watered, mulched, weeded, pruned, sprayed and treated for insect pests and diseases, fertilized, cultivated and otherwise cared for, and shall be protected until final acceptance of the project.
- E. The Contractor shall meet with the City semi-annually during the Guarantee Period to inspect the plantings and shall take immediate action to identify potential problems and undertake corrective measures. If required, the Contractor shall engage professional specialists such as arborists and horticulturists to inspect plant materials, identify problems, recommend and carry out remedial procedures.
- F. Defective work shall be corrected immediately after becoming apparent, weather and season permitting. Plants that die during the Guarantee Period shall be removed at once regardless of the cause of death at no additional charge to the City. Replacement of dead trees will be done immediately if during the specified installation season. If dead tree has been removed

out of planting season, the Contractor shall wait until the beginning of the subsequent planting season, at which time the replacement tree will be planted. If tree to be replaced is a fall hazard species the Contractor shall wait until the beginning of the spring planting season, at which time the replacement tree will be planted.

- G. The Contractor will be responsible for all labor, equipment and materials cost associated with the planting of the replacement plants. When this determination has been made the Contractor shall not be entitled to any further payment for the planting of the replacement plant outside of the payment for the original plant installation.
- H. At the end of the Guarantee Period, the Contractor and the City will meet to inspect the plants to determine if they are acceptable. To be accepted, the work must be in like-new condition. Each tree must exhibit the form typical to its species with at least 75% of its original canopy viable. Any plant that has lost its leader will be rejected.
- I. At the end of the Guarantee Period Each tree must be free of dead branches and shall be pruned for good structure based on industry standards and as directed by the City Arborist.
- J. Based on the inspection, the City will prepare a list of deficiencies in the work. When the deficiencies are corrected to the City's satisfaction, the City will issue a written notice that the Guarantee Period has ended.

3.27 REPLACEMENTS

- A. During the guarantee period, dead, unsightly or unhealthy trees should be removed promptly and replaced by the Contractor as required by the City Arborist.
- B. Vandalized trees should be brought to the attention of the City Arborist.
- C. Replacements shall conform to requirements in the Specifications and shall be replaced as many times as necessary to ensure the establishment of healthy plants. Replacements shall be maintained and guaranteed for two years from the time of replacement, per the terms of the Guarantee Period.

3.28 TREE CONTRACT MANAGEMENT SYSTEM

- A. At the time of tree planting or shortly thereafter, all newly installed trees will be added to the City's tree inventory system by the City Arborist or designee.
- B. The City issued asset management program, supplied by the Cambridge DPW, will be the sole source of accountability to be used for confirmation of work performed and may be used in the calculation of payment required.
- C. The Contractor will be provided with a web accessible tablet computer to be used to record all tree watering within the City's asset management system.

1. The Contractor will be given limited/ restricted web access to view the tree data in order to assist in scheduling and routing of tree planting and watering processes.
 2. Contractor is responsible for any physical damage to the tablet. In the event that the tablet is damaged, it will be replaced by the City at the contractor's expense.
 3. Inappropriate use of the tablet may result in the cancellation of the Contract.
 4. Any technical issues with the equipment must be reported immediately. If the Contractor repeatedly is unable to complete required tasks due to technical issues that the City cannot verify, the Contract may be terminated at the City's discretion.
 5. Reports of all trees watered and maintained by the Contractor will be generated by the City and supplied to the Contractor on a regular basis as needed.
- D. The Contractor shall not be compensated for any tree that is watered, and has not been updated in the asset management system. All payment and quantification of work performed will be based on the Contractor's use of the City's asset management system.
- E. Contractor will be required to update the watering work order, as specified below, at the time each tree is watered or maintained utilizing the City's asset management mobile application with the City issued tablet computer. Recording of trees watered in the City's asset management system is considered incidental to the work of the Contract and not eligible for payment elsewhere. If the watering work order cannot be updated at the time of watering, the Contractor will be responsible for updating work order by end of day the tree was watered. In the event the Contractor is unable to update watering work order with issued tablet computer or desktop computer, Contractor shall email locations to City Arborist at end of day.

3.29 INSPECTION AND ACCEPTANCE

- A. Written notices requesting all inspections must be received by City Arborist at least five days prior to anticipated inspection dates. All work in the Contract shall be found in neat, clean and safe condition.

3.30 SEMI-FINAL INSPECTION

- A. The Contractor may offer for acceptance the entire project or a completed readily defined area, if approved by the City Arborist. Semi-Final inspection will be made by the City Arborist upon completion of all work included herein.

3.31 SEMI-FINAL ACCEPTANCE

- A. The City Arborist will notify Contractor in writing of acceptance in whole or in part of work, exclusive of maintenance and possible replacement of trees subject to guarantee, or of requirements for completion if deficiencies exist. Work will not be submitted for payment without the City Arborist's written acceptance. Semi-Final Acceptance can only occur after the 30 day post-installation watering (2x per week) has been completed and confirmed.

3.32 FINAL INSPECTION AND ACCEPTANCE

- A. At end of maintenance and Guarantee Period, and upon written application from the Contractor, the City Arborist shall determine acceptability of completed work, including watering and maintenance.
- B. Dead, missing or unhealthy trees shall be replaced during next planting season. If a substantial number of plants are unsatisfactory, missing or dead, acceptance will not be granted until replacements are made and the Contractor's responsibility for the maintenance and guarantee (which will require extension) is completed.

PART 4 – COMPENSATION

A. ITEM 100: TREE PLANTING – CONTRACTOR PROVIDED TREES

ITEM 101	SHADE TREE (2" – 2 ½" Caliper)	EACH
ITEM 102	SHADE TREE (2 ½" – 3" Caliper)	EACH
ITEM 103	SHADE TREE (3" – 3 ½" Caliper)	EACH
ITEM 104	ORNAMENTAL TREE (2" – 2 ½" Caliper)	EACH
ITEM 105	ORNAMENTAL TREE (2 ½" – 3" Caliper)	EACH
ITEM 106	ORNAMENTAL TREE (3" – 3 ½" Caliper)	EACH

Method of Measurement

Measurement for payment for Items 101 - 106 Contractor Provided Trees will be for the number of trees of the specified kind and size furnished and planted by the Contractor and accepted in accordance with these Specifications. Representative species of "Shade" and "Ornamental" trees are identified in the Recommended Species list included at the end of these Specifications. Payment for these items will not occur until the tree is planted and accepted. For every Balled and Burlap (B&B) tree installed, the top 2/3 of the wire basket and burlap shall be removed at time of installation and brought back to the Municipal Golf Course tree holding area for verification. Payment will not occur if removed portion of wire basket and burlap is not accounted for.

Basis of Payment / Inclusions

The unit price for Contractor Tree Planted shall be full compensation for all labor tools, equipment, materials, transport and all incidental labor and materials necessary to complete the work, including purchasing and delivering, offloading, receiving, handling and caring for all trees in the laydown area and work sites, transportation between the laydown area and work sites, furnishing and delivering prepared planting soil, mulch, and fertilizer packets, removal of existing surface material at tree pit location, digging of pits, soil management, planting of trees, pruning, staking, guying, wrapping, mulching, weeding, watering (twice/week for first 30 days), cleanup, tree planting establishment work and care, maintenance replacement, Contractor's and City Arborist's costs of selecting and tagging the trees, and for the two (2) year maintenance and guarantee and replacement if required as specified herein, as directed by the Engineer, and as shown and detailed on the Contract Drawings.

Exclusions

No separate payment shall be made for any labor, equipment, and materials incidental to work of this contract, including but not limited to construction signs, disposal of debris, and restoration or

replacement of lawns, shrubs, trees or other improvements to remain, as necessary to complete the work of this section.

B. ITEM 200: TREE PLANTING – CITY PROVIDED TREES

ITEM 201	TREE (B&B, 2” – 2 ½” Caliper)	EACH
ITEM 202	TREE (B&B, 2 ½” – 3” Caliper)	EACH
ITEM 203	TREE (B&B, 3” – 3 ½” Caliper)	EACH
ITEM 204	TREE (B&B, >3 ½” Caliper)	EACH
ITEM 205	TREE (BARE ROOT, 1” – 3” Caliper)	EACH

Method of Measurement

Measurement for payment for Items 201 - 205 City Provided Trees will be for the number of trees of the specified kind and size planted by the Contractor and accepted in accordance with these Specifications. Payment for these items will not occur until the tree is planted and accepted. For every Balled and Burlap (B&B) tree installed, the top 2/3 of the wire basket and burlap shall be removed at time of installation and brought back to the Municipal Golf Course tree holding area for verification. Payment will not occur if removed portion of wire basket and burlap is not accounted for.

Basis of Payment / Inclusions

The unit price for existing City Tree Planted shall be full compensation for all labor tools, equipment, materials, transport and all incidental labor and materials necessary to complete the work, including offloading, receiving, handling and caring for all trees in the laydown area and work sites, transportation between the laydown area and work sites, furnishing and delivering prepared planting soil, mulch, and fertilizer packets, removal of existing surface material at tree pit location, digging of pits, soil management, planting of trees, pruning, staking, guying, wrapping, mulching, weeding, watering (twice/week for first 30 days), cleanup, tree planting establishment work and care, maintenance replacement, Contractor's and City Arborist's costs of selecting and tagging the trees, and for the two (2) year maintenance and guarantee and replacement if required as specified herein, as directed by the Engineer, and as shown and detailed on the Contract Drawings.

Exclusions

No separate payment shall be made for any labor, equipment, and materials incidental to work of this contract, including but not limited to construction signs, disposal of debris, and restoration or replacement of lawns, shrubs, trees or other improvements to remain, as necessary to complete the work of this section. Payment for purchasing trees shall not be paid for under this item.

C. ITEM 300: TREE PIT PREPARATION

ITEM 301	SAWCUT – CONCRETE SIDEWALK	LINEAR FOOT
-----------------	-----------------------------------	--------------------

Method of Measurement

Measurement for payment for this item will be based on the linear feet of concrete pavement sawcut, as per the drawings and directed by the City Arborist.

Basis of Payment / Inclusions

Under the Unit Price for this item, the Contractor shall furnish all labor, materials, tools, equipment, and incidentals required to sawcut concrete pavement as noted on the drawings and directed by the

City Arborist.

ITEM 302 SAWCUT AND STABILIZE – BRICK SIDEWALK LINEAR FOOT

Method of Measurement

Measurement for payment for this item will be based on the linear feet of brick pavement sawcut and stabilized, as per the drawings and directed by the City Arborist.

Basis of Payment / Inclusions

Under the Unit Price for this item, the Contractor shall furnish all labor, materials, tools, equipment, and incidentals required to sawcut and stabilize brick pavement including sawcut and removal of brick, installation of a metal retaining edge and setting of a brick soldier course as noted on the drawings and directed by the City Arborist.

ITEM 303 REMOVE AND DISPOSE TREE GRATE EACH

Method of Measurement

Measurement for payment for this item will be based on each tree grate removed, as per the drawings and directed by the City Arborist.

Basis of Payment / Inclusions

Under the Unit Price for this item, the Contractor shall furnish all labor, materials, tools, equipment, and incidentals required to remove and dispose each tree grate and frame as noted on the drawings and directed by the City Arborist.

D. ITEM 400: WATERING

ITEM 401 WATERING DURING THE 2-YEAR GUARANTEE PERIOD EACH

Method of Measurement

Measurement for payment for Item 401 Watering During the 2-year Guarantee Period will be for each tree watered. In order to quantify trees watered the Contractor will be required to update the work order established with the City's asset management system, at the time each tree is watered. The contractor shall not be compensated for any tree that is watered, and has not been updated in the asset management system. All payment and quantification of work performed will be based on the Contractor's use of the City's asset management system.

Basis of Payment / Inclusions

The unit price for Watering During the 2-year Guarantee Period shall be full compensation for all labor tools, equipment, materials, transport and all incidental labor and materials necessary to complete the work, including furnishing and delivering water, watering approximately once a week or as directed by the City Arborist for the 2-year guarantee period, managing watering and maintenance operations utilizing the City's Asset Management System, utilizing the City supplied tablet computer to record all tree watering operations as specified herein and as directed by the Engineer.

Exclusions

No separate payment shall be made for any labor, equipment, and materials incidental to work of this contract, including but not limited to attendance at training to use the City's Asset Management

System, recording of trees watered or other tasks necessary to complete the work of this section.

E. INVOICING

1. Billing for the work under this contract is to occur monthly unless otherwise indicated, at the City's discretion. Invoices are to be itemized based on the unit prices on the bid sheet. All invoices are to be accompanied with the planting locations and species installed. **The full scientific name including the 'variety' or 'cultivar' for each tree installed is to be included.**
2. Each month the Contractor is to electronically send a draft invoice to the City Arborist prior to sending the actual invoice. The Contract Supervisor will review the draft and make any necessary corrections and return it back to the Contractor. At which time the Contractor is to submit the actual invoice.
3. All quantities are estimates. The city makes no guarantee as to final number of trees to be planted.

Year 1: 2016

ITEM NO.	APPROX. QTY	ITEM WITH UNIT BID PRICE WRITTEN IN WORDS	UNIT PRICE		AMOUNT	
			Dollars	Cents	Dollars	Cents
101	200	SHADE TREE (2" – 2 ½" Caliper)				
		at				
		Dollars				
		per EACH				
102	10	SHADE TREE (2 ½" – 3" Caliper)				
		at				
		Dollars				
		per EACH				
103	10	SHADE TREE (3" – 3 ½" Caliper)				
		at				
		Dollars				
		per EACH				
104	75	ORNAMENTAL TREE (2" – 2 ½" Caliper)				
		at				
		Dollars				
		per EACH				
105	10	ORNAMENTAL TREE (2 ½" – 3" Caliper)				
		at				
		Dollars				
		per EACH				
106	10	ORNAMENTAL TREE (3" – 3 ½" Caliper)				
		at				
		Dollars				
		per EACH				

ITEM NO.	APPROX. QTY	ITEM WITH UNIT BID PRICE WRITTEN IN WORDS	UNIT PRICE		AMOUNT	
			Dollars	Cents	Dollars	Cents
201	20	TREE (B&B, 2" – 2 ½" Caliper)				
		at				
		Dollars				
		per EACH				
202	15	TREE (B&B, 2 ½" – 3" Caliper)				
		at				
		Dollars				
		per EACH				
203	10	TREE (B&B, 3" – 3 ½" Caliper)				
		at				
		Dollars				
		per EACH				
204	10	TREE (B&B, >3 ½" Caliper)				
		at				
		Dollars				
		per EACH				
205	20	TREE (BARE ROOT, 1" – 3" Caliper)				
		at				
		Dollars				
		per EACH				
301	400	SAWCUT – CONCRETE SIDEWALK				
		at				
		Dollars				
		per LINEAR FOOT				

ITEM NO.	APPROX. QTY	ITEM WITH UNIT BID PRICE WRITTEN IN WORDS	UNIT PRICE		AMOUNT	
			Dollars	Cents	Dollars	Cents
302	400	SAWCUT AND STABILIZE – BRICK SIDEWALK				
		at				
		Dollars				
		per LINEAR FOOT				
303	20	REMOVE AND DISPOSE TREE GRATE				
		at				
		Dollars				
		per EACH				
401	1	WATERING DURING 2-YEAR GUARANTEE PERIOD				
		at				
		Dollars				
		per EACH				
			TOTAL			

Year 2: 2017

ITEM NO.	APPROX. QTY	ITEM WITH UNIT BID PRICE WRITTEN IN WORDS	UNIT PRICE		AMOUNT	
			Dollars	Cents	Dollars	Cents
101	200	SHADE TREE (2" – 2 ½" Caliper)				
		at				
		Dollars				
		per EACH				
102	10	SHADE TREE (2 ½" – 3" Caliper)				
		at				
		Dollars				
		per EACH				
103	10	SHADE TREE (3" – 3 ½" Caliper)				
		at				
		Dollars				
		per EACH				
104	75	ORNAMENTAL TREE (2" – 2 ½" Caliper)				
		at				
		Dollars				
		per EACH				
105	10	ORNAMENTAL TREE (2 ½" – 3" Caliper)				
		at				
		Dollars				
		per EACH				
106	10	ORNAMENTAL TREE (3" – 3 ½" Caliper)				
		at				
		Dollars				
		per EACH				

ITEM NO.	APPROX. QTY	ITEM WITH UNIT BID PRICE WRITTEN IN WORDS	UNIT PRICE		AMOUNT	
			Dollars	Cents	Dollars	Cents
201	20	TREE (B&B, 2" – 2 ½" Caliper)				
		at				
		Dollars				
		per EACH				
202	15	TREE (B&B, 2 ½" – 3" Caliper)				
		at				
		Dollars				
		per EACH				
203	10	TREE (B&B, 3" – 3 ½" Caliper)				
		at				
		Dollars				
		per EACH				
204	10	TREE (B&B, >3 ½" Caliper)				
		at				
		Dollars				
		per EACH				
205	20	TREE (BARE ROOT, 1" – 3" Caliper)				
		at				
		Dollars				
		per EACH				
301	400	SAWCUT – CONCRETE SIDEWALK				
		at				
		Dollars				
		per LINEAR FOOT				

ITEM NO.	APPROX. QTY	ITEM WITH UNIT BID PRICE WRITTEN IN WORDS	UNIT PRICE		AMOUNT	
			Dollars	Cents	Dollars	Cents
302	400	SAWCUT AND STABILIZE – BRICK SIDEWALK				
		at				
		Dollars				
		per LINEAR FOOT				
303	20	REMOVE AND DISPOSE TREE GRATE				
		at				
		Dollars				
		per EACH				
401	1	WATERING DURING 2-YEAR GUARANTEE PERIOD				
		at				
		Dollars				
		per EACH				
			TOTAL			

Total combined bid for years one and two:

(Amount in Words)

\$

(Amount in Figures)

Print Name of person submitting bid

Phone Number

Signature of person submitting bid

Company Name and Address

END OF SECTION 02910

REQUIRED TREE PLANTING SETBACKS

Requirement	Cambridge, MA
Minimum Tree Pit Size	2' x 8'
Minimum Distance from Street Intersections	20'
Minimum Distance from Street Lights	10' min. varies with species
Minimum Distance from Underground Utility Lines	3' from edge of tree well
Minimum Distance from Driveways	3' from edge of tree well
Minimum Distance from Fire Hydrants	3' from edge of tree well
Minimum Distance from Adjacent Trees	15'-40' (varies with species)
Minimum Distance from Utility Poles	3' from edge of tree well
Minimum Distance from Stop Sign	20' from edge of tree well
Minimum Distance from Traffic Signs	Coordinate with TP&T, depends on sightline requirements
Suggested Distance from Parking Meters	outside tree well
Minimum Distance from Gas or Water Valve	2' from edge of tree well
Minimum Distance from Oil Fill Pipe	2' from edge of tree well
Minimum Distance from Coal Chute	2' to edge of tree well
Minimum Distance from edge of pit to any opposite obstructions	36" for existing tree, 48" for new tree
Minimum passage for ADA considerations	36" for existing tree, 48" for new tree

RECOMMENDED SPECIES

This list contains trees that the City currently installs as street trees.

Shade Tree (no wires present)	Height (feet)
American elm (<i>Ulmus americana</i>)	50-70
Armstrong Red maple (<i>Acer x freemanii</i>)	50-70
Black oak (<i>Quercus velutina</i>)	50-60
Black tupelo (<i>Nyssa sylvatica</i>)	30-50
Dawn redwood (<i>Metasequoia glyptostroboides</i>)	75
Elm cultivars (<i>Ulmus sp.</i>)	40-60
Ginkgo (<i>Ginkgo biloba</i>)	40-80
Golden raintree (<i>Koelreuteria paniculata</i>)	30-40
Hackberry (<i>Celtis occidentalis</i>)	60
Honeylocust (<i>Gleditsia triacanthos</i>)	45-50
Hornbeam (<i>Carpinus caroliniana</i>)	35
Katsuratree (<i>Cercidiphyllum japonicum</i>)	50
Kentucky coffeetree (<i>Gymnocladus dioicus</i>)	75
Littleleaf linden (<i>Tilia cordata</i>)	45-60
London planetree (<i>Platanus x acerifolia</i>)	80
Pear spp (<i>Pyrus sp.</i>)	30-40
Pin oak (<i>Quercus palustris</i>)	75
Red maple (<i>Acer rubrum</i>)	40-70
Red oak (<i>Quercus rubra</i>)	75
River birch (<i>Betula nigra</i>)	50-70
Silver linden (<i>Tilia tormentosa</i>)	30-40
Sophora (<i>Sophora (Styphnolobium) japonica</i>)	50
Swamp White oak (<i>Quercus bicolor</i>)	45
Sweetgum (<i>Liquidambar styraciflua</i>)	65
Tuliptree (<i>Liriodendron tulipifera</i>)	70-90
Zelkova (<i>Zelkova serrata</i>)	50-70

Ornamental Tree (overhead wires present)	Height (feet)
Amur maackia (<i>Maackia amurensis</i>)	20-30
Accolade cherry (<i>Prunus 'Accolade'</i>)	20
Akebono cherry (<i>Prunus x yedoensis 'Akebono'</i>)	25
Autumn cherry (<i>Prunus subhirtella 'Autumnalis'</i>)	25-40
Crabapple spp (<i>Malus sp.</i>)	15-25
Eastern redbud (<i>Cercis canadensis</i>)	20-30
Hedge Maple (<i>Acer campestre</i>)	25-30
Japanese tree lilac (<i>Syringa reticulata</i>)	20-30
Kwanzan cherry (<i>Prunus serrulata 'Kwanzan'</i>)	25
Okame cherry (<i>Prunus x incam 'Okame'</i>)	15-25
Paperbark maple (<i>Acer griseum</i>)	30
Sargent cherry (<i>Prunus sargentii</i>)	25-40
Serviceberry (<i>Amelanchier sp.</i>)	20-30
Snowgoose cherry (<i>Prunus serrulata 'Snowgoose'</i>)	20

Note: Usage of these species depends upon availability and season.

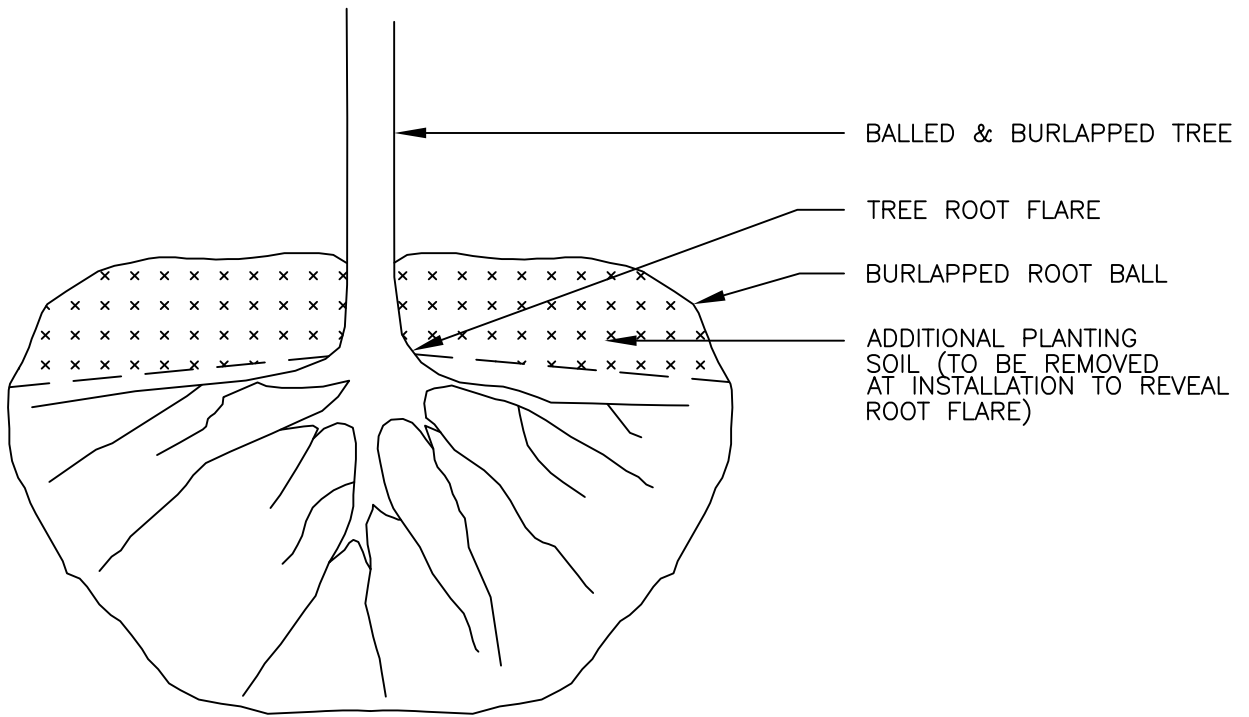

NOTE:
 TREE TO BE PLANTED WITH EXPOSED ROOT FLARE 1"–3" ABOVE FINISHED GRADE AT CURB



LOCATING THE ROOT FLARE

CITY OF CAMBRIDGE STANDARD SPECIFICATIONS AND DETAILS

SCALE: NTS

DATE: JANUARY 2022
 OF ISSUE:

SPEC. SECTION REF#: 02910

1 OF 6

TREE CROWN AND TRUNK SHALL BE FREE OF DEFECTS AND TRUE TO FORM

TIE STRAPS FIRMLY AROUND TRUNK BUT STILL ALLOW MINOR TRUNK SWAY

ARBOR TIE OR OTHER WIDE, NON-ABRASIVE BELT STRAPPING

MULCH 2" DEPTH AT EDGE OF TREE WELL

TAPER TO 0" AT ROOT FLARE

FOR BALLED AND BURLAP TREES, CUT AND REMOVE BURLAP AND WIRE BASKET

PLACE ROOT BALL ON COMPACTED OR UNDISTURBED SOIL

NOTES:

- 4'-0" MIN. SIDEWALK WIDTH IS A REQUIREMENT OF THE CITY OF CAMBRIDGE
- TREES SHALL NOT BE PLANTED:
 - WITHIN 20' FROM THE CORNER OF INTERSECTING STREETS
 - WITHIN 10' FROM A LIGHT POLE
 - WITHIN 20' FROM STOP SIGNS
 - WITHIN 3' FROM UTILITIES
 - WITHIN 3' FROM HYDRANTS
 - WITHIN 3' FROM DRIVEWAYS
- * SEE SPECIFICATIONS FOR COMPLETE LIST

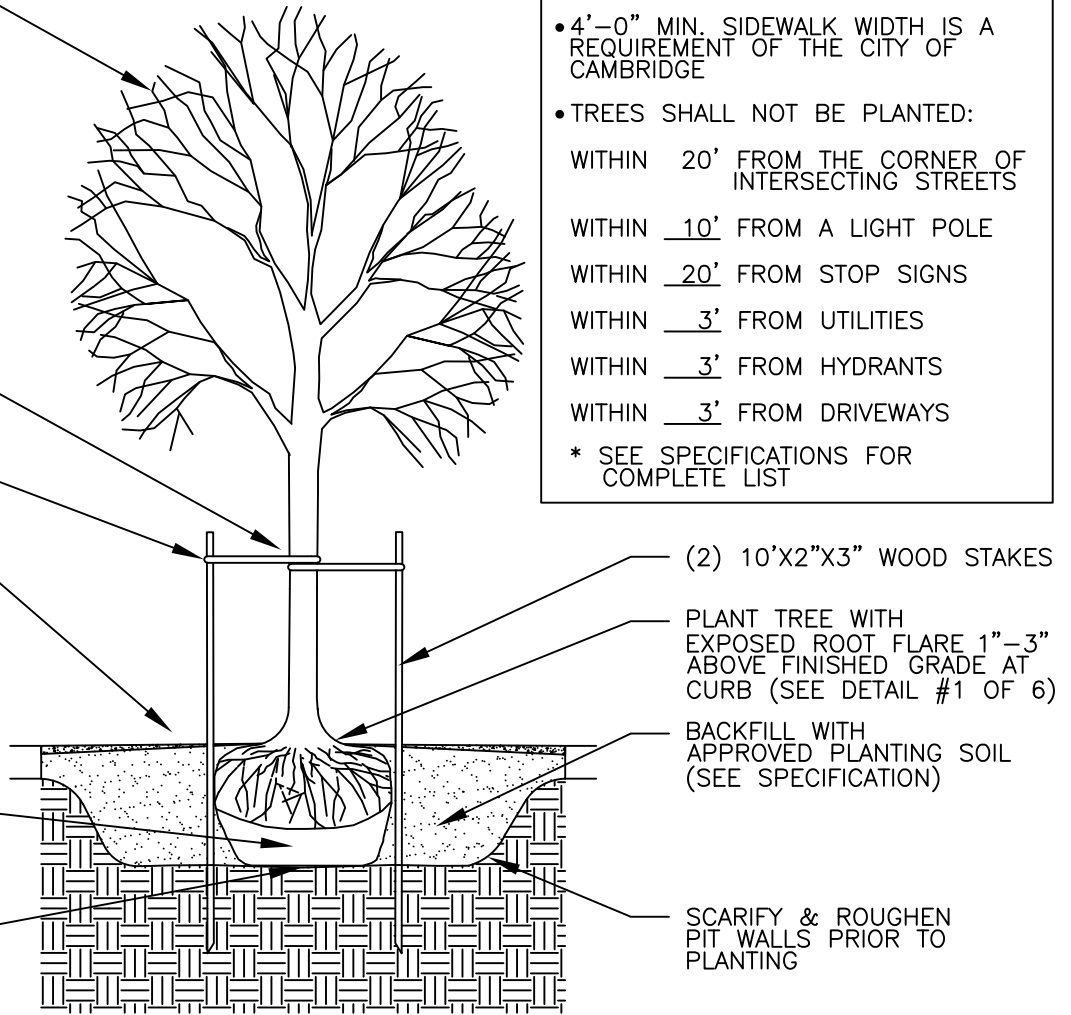

SECTION

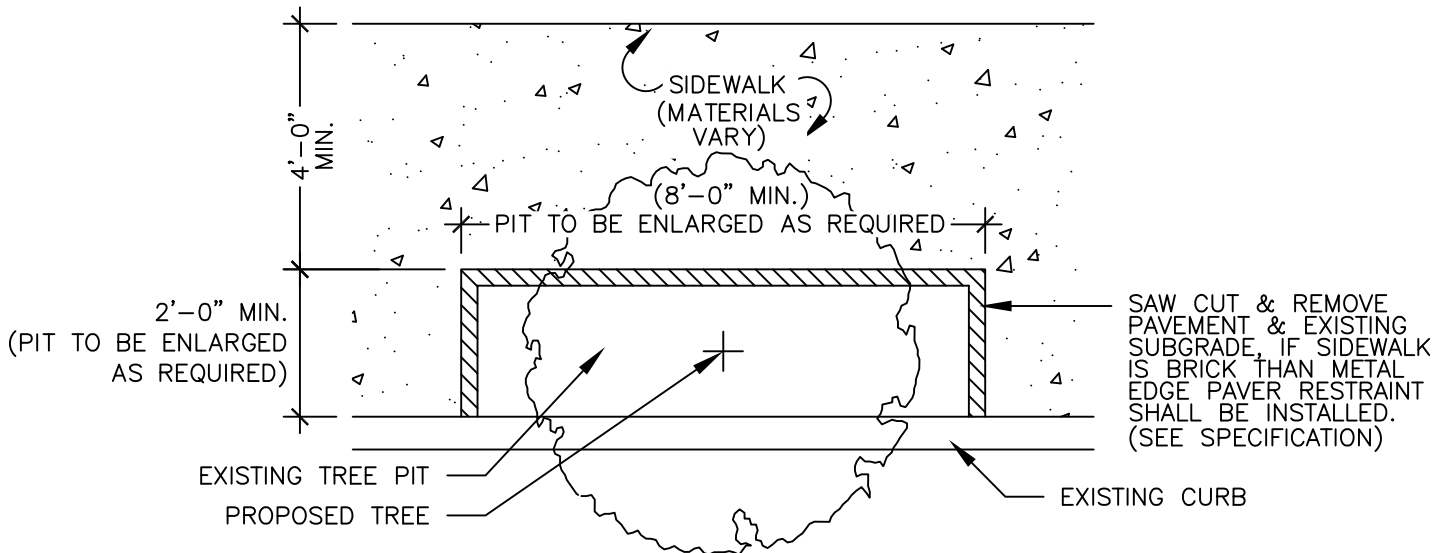

PLAN



TREE PLANTING DETAIL
(REPLACEMENT AT EXISTING TREE PIT)

CITY OF CAMBRIDGE STANDARD SPECIFICATIONS AND DETAILS

SCALE: NTS

DATE OF ISSUE: JANUARY 2022

SPEC. SECTION REF#: 02910

2 OF 6

TREE CROWN AND TRUNK SHALL BE FREE OF DEFECTS AND TRUE TO FORM

TIE STRAPS FIRMLY AROUND TRUNK BUT STILL ALLOW MINOR TRUNK SWAY

ARBOR TIE OR OTHER WIDE, NON-ABRASIVE BELT STRAPPING

MULCH 2" DEPTH AT EDGE OF TREE WELL

TAPER TO 0" AT ROOT FLARE

FOR BALLED AND BURLAP TREES, CUT AND REMOVE BURLAP AND WIRE BASKET

PLACE ROOT BALL ON COMPACTED OR UNDISTURBED SOIL

NOTES:

- 4'-0" MIN. SIDEWALK WIDTH IS A REQUIREMENT OF THE CITY OF CAMBRIDGE
- TREES SHALL NOT BE PLANTED:
 - WITHIN 20' FROM THE CORNER OF INTERSECTING STREETS
 - WITHIN 10' FROM A LIGHT POLE
 - WITHIN 20' FROM STOP SIGNS
 - WITHIN 3' FROM UTILITIES
 - WITHIN 3' FROM HYDRANTS
 - WITHIN 3' FROM DRIVEWAYS
- * SEE SPECIFICATIONS FOR COMPLETE LIST

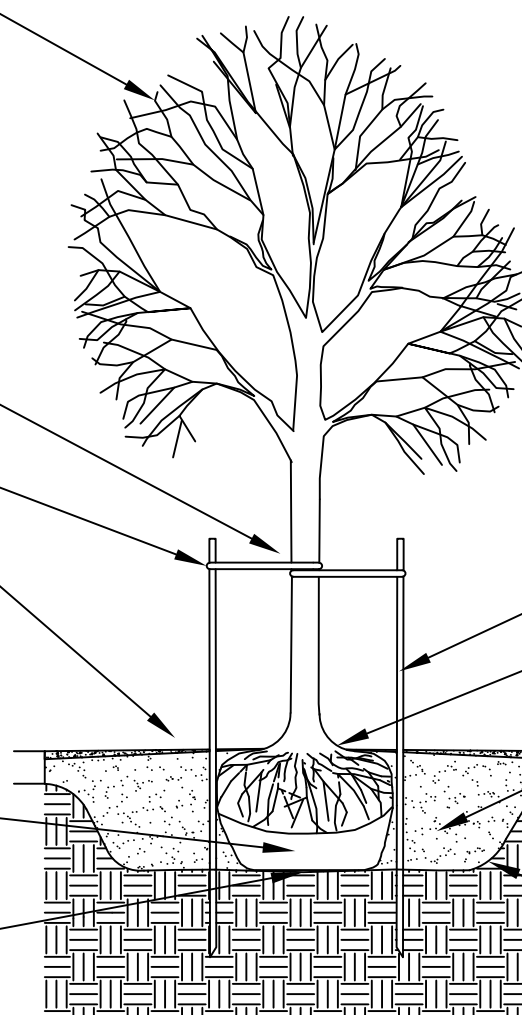

(2) 10'X2'X3" WOOD STAKES

PLANT TREE WITH EXPOSED ROOT FLARE 1"-3" ABOVE FINISHED GRADE AT CURB (SEE DETAIL #1 OF 6)

BACKFILL WITH APPROVED PLANTING SOIL (SEE SPECIFICATION)

SCARIFY & ROUGHEN PIT WALLS PRIOR TO PLANTING

SECTION

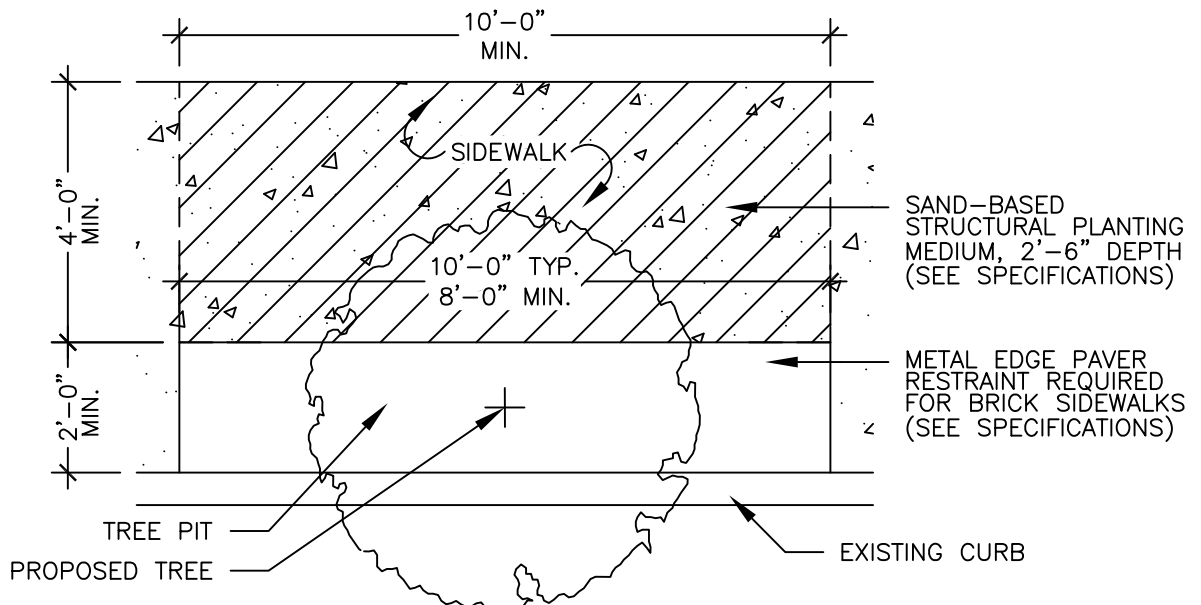

SAND-BASED STRUCTURAL PLANTING MEDIUM, 2'-6" DEPTH (SEE SPECIFICATIONS)

METAL EDGE PAVER RESTRAINT REQUIRED FOR BRICK SIDEWALKS (SEE SPECIFICATIONS)

PLAN



**TREE PLANTING DETAIL
(6' SIDEWALK WIDTH)**

CITY OF CAMBRIDGE STANDARD SPECIFICATIONS AND DETAILS

SCALE: NTS	DATE OF ISSUE: JANUARY 2022	SPEC. SECTION REF#: 02910	# 3 OF 6
------------	-----------------------------	---------------------------	----------

TREE CROWN AND TRUNK SHALL BE FREE OF DEFECTS AND TRUE TO FORM

TIE STRAPS FIRMLY AROUND TRUNK BUT STILL ALLOW MINOR TRUNK SWAY

ARBOR TIE OR OTHER WIDE, NON-ABRASIVE BELT STRAPPING

MULCH 2" DEPTH AT EDGE OF TREE WELL

TAPER TO 0" AT ROOT FLARE

FOR BALLED AND BURLAP TREES, CUT AND REMOVE BURLAP AND WIRE BASKET

PLACE ROOT BALL ON COMPACTED OR UNDISTURBED SOIL

NOTES:

- 4'-0" MIN. SIDEWALK WIDTH IS A REQUIREMENT OF THE CITY OF CAMBRIDGE
- TREES SHALL NOT BE PLANTED:
 - WITHIN 20' FROM THE CORNER OF INTERSECTING STREETS
 - WITHIN 10' FROM A LIGHT POLE
 - WITHIN 20' FROM STOP SIGNS
 - WITHIN 3' FROM UTILITIES
 - WITHIN 3' FROM HYDRANTS
 - WITHIN 3' FROM DRIVEWAYS
- * SEE SPECIFICATIONS FOR COMPLETE LIST

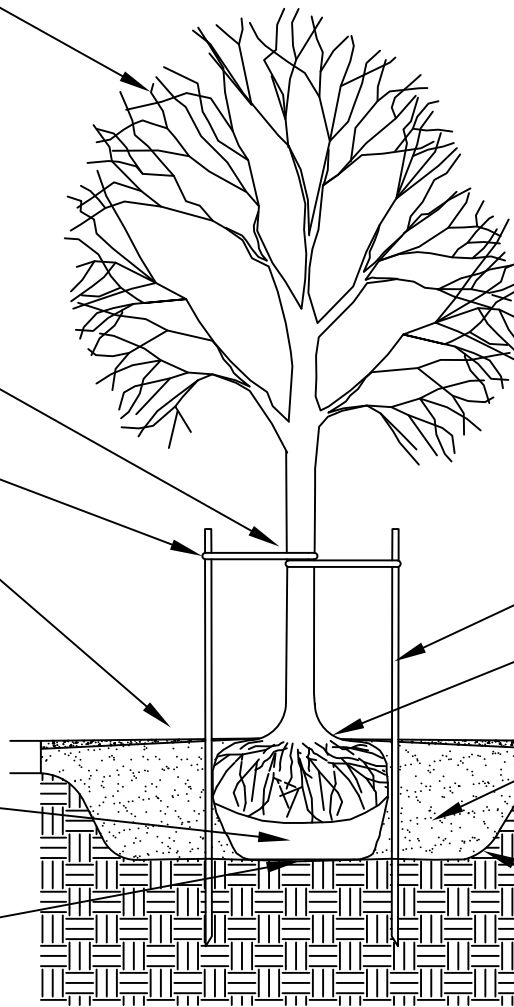

(2) 10'X2"X3" WOOD STAKES

PLANT TREE WITH EXPOSED ROOT FLARE 1"-3" ABOVE FINISHED GRADE AT CURB (SEE DETAIL #1 OF 6)

BACKFILL WITH APPROVED PLANTING SOIL (SEE SPECIFICATION)

SCARIFY & ROUGHEN PIT WALLS PRIOR TO PLANTING

SECTION

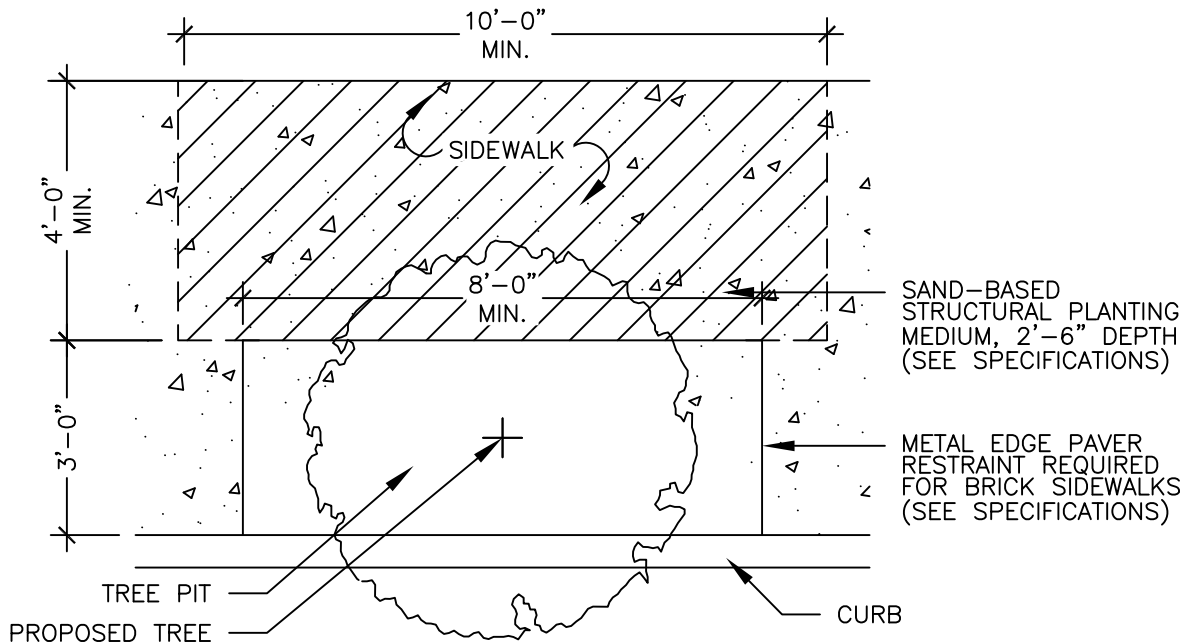

SAND-BASED STRUCTURAL PLANTING MEDIUM, 2'-6" DEPTH (SEE SPECIFICATIONS)

METAL EDGE PAVER RESTRAINT REQUIRED FOR BRICK SIDEWALKS (SEE SPECIFICATIONS)

TREE PIT

PROPOSED TREE

CURB

PLAN



TREE PLANTING DETAIL
(7' SIDEWALK WIDTH)

CITY OF CAMBRIDGE STANDARD SPECIFICATIONS AND DETAILS

SCALE: NTS

DATE OF ISSUE: JANUARY 2022

SPEC. SECTION REF#: 02910

4 OF 6

TREE CROWN AND TRUNK SHALL BE FREE OF DEFECTS AND TRUE TO FORM

TIE STRAPS FIRMLY AROUND TRUNK BUT STILL ALLOW MINOR TRUNK SWAY

ARBOR TIE OR OTHER WIDE, NON-ABRASIVE BELT STRAPPING

MULCH 2" DEPTH AT EDGE OF TREE WELL

TAPER TO 0" AT ROOT FLARE

FOR BALLED AND BURLAP TREES, CUT AND REMOVE BURLAP AND WIRE BASKET

PLACE ROOT BALL ON COMPACTED OR UNDISTURBED SOIL

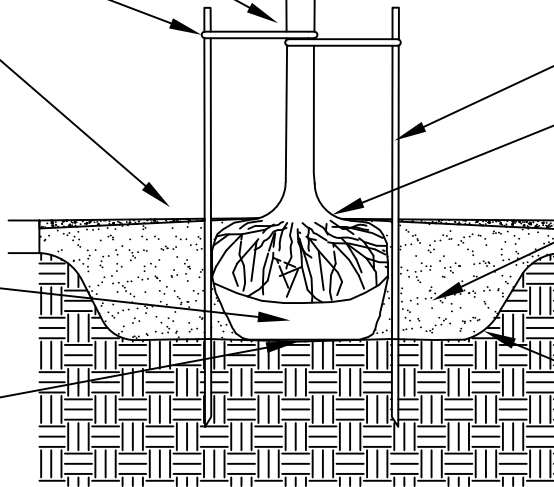
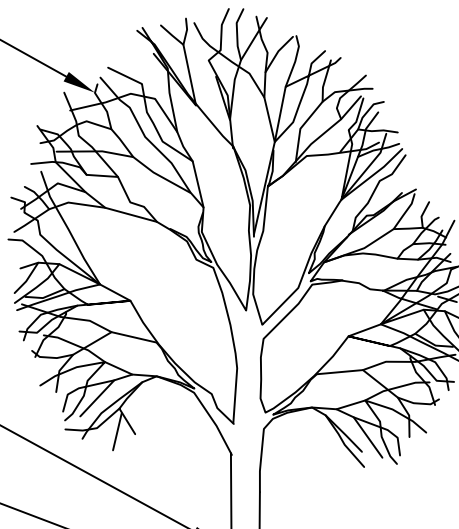

NOTES:

- 4'-0" MIN. SIDEWALK WIDTH IS A REQUIREMENT OF THE CITY OF CAMBRIDGE
- TREES SHALL NOT BE PLANTED:
 - WITHIN 20' FROM THE CORNER OF INTERSECTING STREETS
 - WITHIN 10' FROM A LIGHT POLE
 - WITHIN 20' FROM STOP SIGNS
 - WITHIN 3' FROM UTILITIES
 - WITHIN 3' FROM HYDRANTS
 - WITHIN 3' FROM DRIVEWAYS
- * SEE SPECIFICATIONS FOR COMPLETE LIST

(2) 10'X2"X3" WOOD STAKES

PLANT TREE WITH EXPOSED ROOT FLARE 1"-3" ABOVE FINISHED GRADE AT CURB (SEE DETAIL #1 OF 6)

BACKFILL WITH APPROVED PLANTING SOIL (SEE SPECIFICATION)

SCARIFY & ROUGHEN PIT WALLS PRIOR TO PLANTING

SECTION

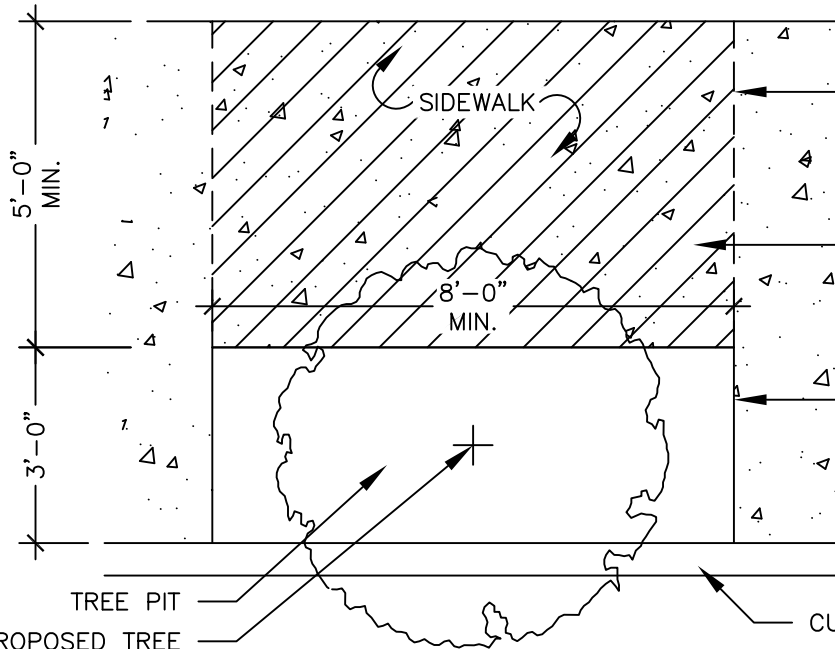

LIMITS OF STRUCTURAL PLANTING MEDIUM ALIGNED WITH EDGES OF TREE PIT

SAND-BASED STRUCTURAL PLANTING MEDIUM, 2'-6" DEPTH (SEE SPECIFICATIONS)

METAL EDGE PAVER RESTRAINT REQUIRED FOR BRICK SIDEWALK (SEE SPECIFICATIONS)

PLAN

TREE PIT
PROPOSED TREE

CURB



**TREE PLANTING DETAIL
(8' SIDEWALK WIDTH)**

CITY OF CAMBRIDGE STANDARD SPECIFICATIONS AND DETAILS

SCALE: NTS	DATE OF ISSUE: JANUARY 2022	SPEC. SECTION REF#: 02910	# 5 OF 6
------------	-----------------------------	---------------------------	----------

TREE CROWN AND TRUNK SHALL BE FREE OF DEFECTS AND TRUE TO FORM

TIE STRAPS FIRMLY AROUND TRUNK BUT STILL ALLOW MINOR TRUNK SWAY

ARBOR TIE OR OTHER WIDE, NON-ABRASIVE BELT STRAPPING

MULCH 2" DEPTH AT EDGE OF TREE WELL

TAPER TO 0" AT ROOT FLARE

FOR BALLED AND BURLAP TREES, CUT AND REMOVE BURLAP AND WIRE BASKET

PLACE ROOT BALL ON COMPACTED OR UNDISTURBED SOIL

NOTES:

- 4'-0" MIN. SIDEWALK WIDTH IS A REQUIREMENT OF THE CITY OF CAMBRIDGE
- TREES SHALL NOT BE PLANTED:
 - WITHIN 20' FROM THE CORNER OF INTERSECTING STREETS
 - WITHIN 10' FROM A LIGHT POLE
 - WITHIN 20' FROM STOP SIGNS
 - WITHIN 3' FROM UTILITIES
 - WITHIN 3' FROM HYDRANTS
 - WITHIN 3' FROM DRIVEWAYS
- * SEE SPECIFICATIONS FOR COMPLETE LIST

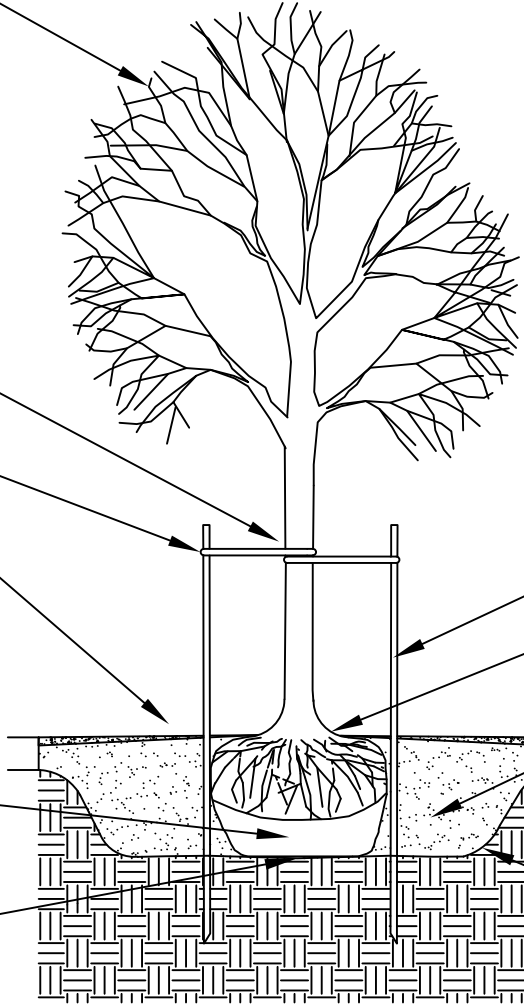

SECTION

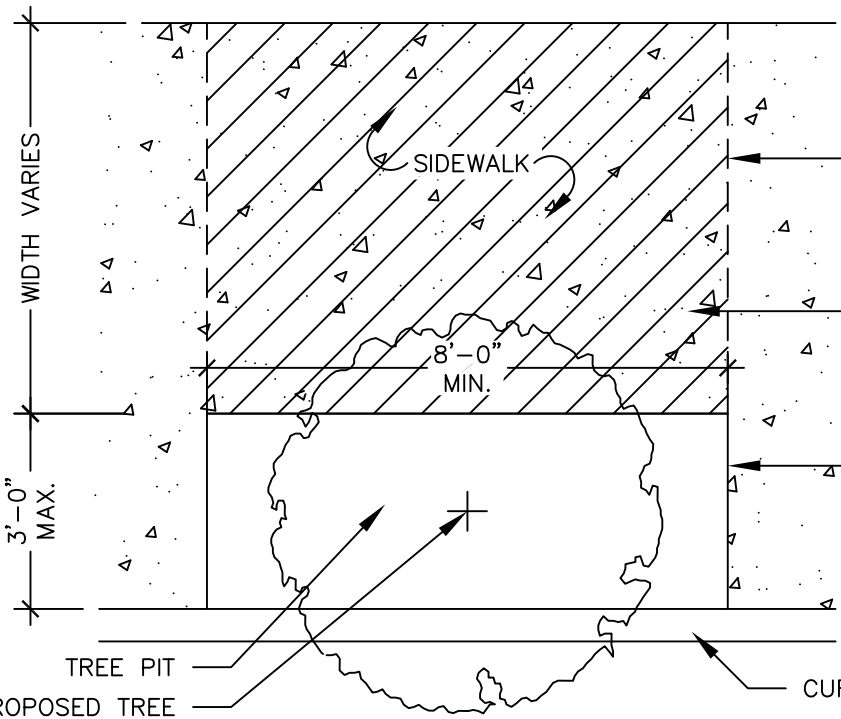

PLAN



TREE PLANTING DETAIL (>8' SIDEWALK WIDTH)

CITY OF CAMBRIDGE STANDARD SPECIFICATIONS AND DETAILS

SCALE: NTS

DATE OF ISSUE: JANUARY 2022

SPEC. SECTION REF#: 02910

6 OF 6